



Self-study programme 562

Infotainment and Car-Net in T6 2016 and Caddy 2016



With the market launch of the Caddy 2016 and Transporter T6, the "Commercial Vehicles" brand is also entering the generation of the modular infotainment system (MIB). This means the customer will have the opportunity to experience the benefits of comfort and infotainment all over again.

With the "Discover Media" radio navigation system, the customer is provided with the technology of "mobile online services" or "Car-Net - Guide & Inform". These also provide access to the Internet from the vehicle. Various services can be used via a dedicated customer portal. For example, it is possible to download destinations before starting driving, which can then be imported easily during the journey.

It is possible to operate and display various apps provided by Volkswagen using the infotainment system of the vehicle ("Discover Media" and "Composition Media"), as well as being able to operate and control third-party apps that were already installed on the smartphone.

There are three interfaces to achieve this function: MirrorLink™ apps, the new CarPlay™ function from Apple and Android Auto™ from Google.



S562_002



The German displays shown in this booklet are only intended as examples, and do not correspond to the displays in the relevant national languages.

Self-Study Programme presents the design and function of new developments! The content will not be updated.

Current testing, setting and repair instructions can be found in the service literature provided.



Important Note

At a glance

Radios and navigation system	4
The Composition Audio radio	4
The Composition Colour radio	5
The Composition Media radio	6
The Discover Media radio navigation system	7
External media interfaces	11
The external media interfaces	11
The installation locations of the media interfaces	12
Mobile phone preparations	13
The mobile telephone interface	13
The "Comfort" mobile telephone interface	14
Internet connection	16
Preconditions	16
The Car-Stick	16
The WLAN	17
Sound system	18
The "DYNAUDIO" digital sound system in the T6 2016	18
Aerial concept	19
The aerial concept in the Caddy 2016	19
The aerial concept in the T6 2016	20
Car-Net	21
The Car-Net	21
The Car-Net App-Connect service	22
The Car-Net Guide & Inform service	26
The Service portlet	34
Glossary	36

Radios and navigation system

The following pages provide an overview of the radio and radio navigation systems that are available for the Caddy 2016 and the T6 2016. The modular infotainment system (MIB-PQ) is used in the Caddy 2016 and T6 2016 for the first time. This means radios from the MIB-PQ are used almost exclusively. Only one radio version is not part of the MIB-PQ.

The Composition Audio radio

The Composition Audio radio is the entry-level variant of the radio systems for the Caddy 2016 and T6 2016. This radio is not part of the modular infotainment system (MIB-PQ).

In service, the designation is "Radio R".

The Composition Audio is not a part of the component protection.

As with the previous models, it is activated by entering a code.



Technical features

- TFT monochrome display
- Output power of 4 x 20 watt
- AM/FM single tuner
- MP3, WMA format support
- SD card reader
- AUX-IN
- USB

Optional

- Bluetooth interface for mobile phones (HFP, PBAP, A2DP, AVRCP)

The following radio and radio navigation systems are part of the modular infotainment system (MIB-PQ) an. They are components of the component protection. Their designation for service is "Control unit 1 for infotainment electronics J794". The following equipment versions are available for the Caddy 2016 and T6 2016:

- Composition Colour radio
- Composition Media radio
- Discover Media radio/navigation system

Composition Colour radio

This device has an integrated CD player. The CD slot is located above the colour display. The SD card reader and AUX-IN connection are located underneath the colour display.



S562_008

Technical features

- Resistive 5"-TFT colour display 400 x 240 pixels
- Output power of 4 x 20 watt
- FM phase diversity, AM
- CD-player
- MP3, WMA format support
- SD card reader
- AUX-IN

Optional

- Bluetooth (HFP, A2DP, PBAP, AVRCP)
- DAB+
- USB multimedia interface or USB with Apple support external
- Reversing camera display

Radios and navigation system

The Composition Media radio

As an expansion to the Composition Colour radio, this device includes proximity sensors, amongst other features. As a result of the proximity sensor, the SD card reader is located on the left next to the colour display.

Optionally, this device can be equipped with electronic voice amplification.



SD card reader Proximity sensor

S562_028

Technical features

In addition to the features of the composition colour radio, this device configuration has the following features:

- Capacitive touchscreen 6.33-inch TFT colour display WVGA, 800 x 480 pixels
- Proximity sensors*
- AAC, FLAC audio format support
- JPEG viewer
- Bluetooth (HFP, A2DP, PBAP, AVRCP, MAP, 2 mobile phones can be paired simultaneously via HFP)
- SD card reader
- AUX-IN**
- USB multimedia interface with external Apple support **

Optional

- DAB+
- Voice control
- Electronic voice amplification
- Car-Net App-Connect

* Proximity sensors:

When a finger approaches the display, the virtual buttons are increased in size.

** External interfaces:

Fitting combinations of the external interfaces (AUX-IN, USB, USB with Apple support) may vary depending on equipment.

The Discover Media radio navigation system

The Discover Media radio navigation system is also marketed under the name Discover Media Plus in conjunction with certain equipment packages.

One-shot destination entry

The navigation system can be operated by voice input. The destination is entered in a coherent spoken phrase instead of sequential requests for the address components.



SD map reader 1

SD map reader 2

S562_010

Personal POIs (point of interest)*

A Personal POI database can be created on the Volkswagen portal and transferred to the Discover Media via SD card. The data is converted using the Nav Companion Internet application. Personal POIs can be displayed on the navigation map and used for POI searches.

Technical features

In addition to the features of the Composition Media radio, this device configuration has the following characteristics:

- 2 SD card readers**
- Navigation function
 - Personal points of interest (POI)
 - Preset POIs
 - 2D/3D map display

Optional

- WLAN (see page 17)
- Voice control with one-shot destination entry
- Car-Net Guide & Inform
- Media Control

* Personal POIs can also be imported via the Car-Net customer portal when Guide & Inform services are activated, and transferred to the Discover Media via an Internet connection.

** One of the two SD card readers is permanently required for dynamically loading the map and navigation data.

Radios and navigation system

Electronic voice amplification

The electronic voice amplification assists the driver in communicating with passengers. This involves picking up the driver's voice using the hands-free microphone of the radio, and transferring it to the rear loudspeakers. At the same time, disruptive ambient noise is filtered out to the greatest possible extent. If audio playback is in progress, the driver's voice is blended in. This means the driver can easily be understood even from the rear seats, and does not have to turn around when driving in order to communicate with the passengers.



S562_068

Setting the volume of the electronic voice amplification

The volume can be adjusted in the "Volume settings" menu. The corresponding menu is opened by touching the button for electronic voice amplification. This button appears on the right next to the volume bar when the volume of the audio playback is changed. The volume of the electronic voice amplification can now be set using a slider.

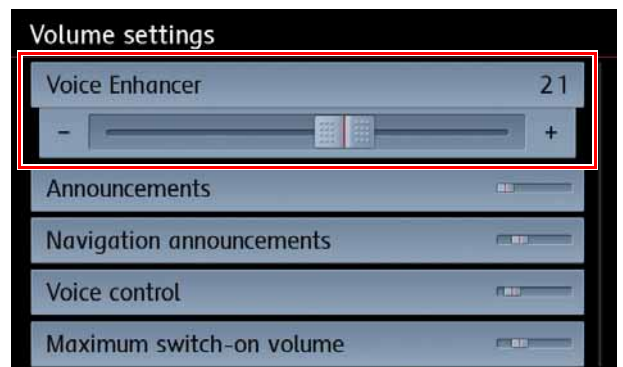

S562_029

Media Control

Media Control enables the user to control the Discover Media radio navigation system remotely using an app.

The Volkswagen Media Control app can be downloaded from the Apple App Store and the Google Play Store for smartphone and Tablet PC. The app is free.

Access is via WLAN. It is necessary for the Discover Media radio navigation system and the mobile device to be in the same WLAN network. In addition, the data transfer for mobile devices must be activated in the settings of the Discover Media.



S562_067

Once the connection has been established, the following functions can be controlled using the Media Control app:

- Radio
- Media-Player
- Volume and sound settings
- Selection of navigation destinations from the app:
 - Calendar
 - Address book
 - Favourites list
 - Google
- Start or stop route guidance

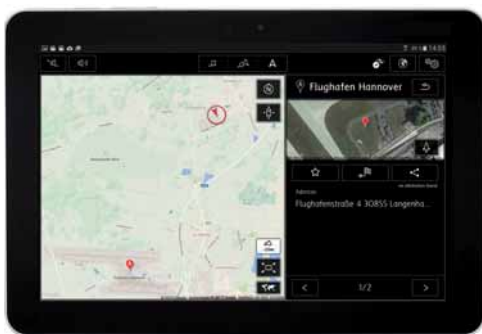

S562_063



S562_065



S562_064



S562_066

Radios and navigation system

Map and navigation data

The map and navigation data is stored on an SD card specially developed for automotive applications. Conventional SD cards cannot be used as storage media for this data. If the original SD card is lost or damaged, a new one can be obtained from your Volkswagen partner.

The navigation data is not transferred to the navigation system, but is called for dynamically, which means the SD card must always be left in one of the two SD card readers.

Update of the map and navigation data

Map and navigation data may become out of date over time. In this case, it is recommended for the data to be updated. There are two variants for this.

Variant 1

This variant involves the customer exchanging the SD card. A new SD card containing up-to-date navigation data is available at the Volkswagen partner.

Variant 2

The second variant involves updating the map and navigation data using the Volkswagen Internet portal. Current data is made available here twice a year. There are also instructions for downloading the data onto the SD card. To prevent downloading incompatible data, it is essential to select the correct vehicle or navigation system.



S562_035

The external media interfaces

The Caddy 2016 and T6 2016 can be equipped with three different variants of external media interfaces.

USB connection

Depending on equipment, the Composition Colour radio can be fitted with or without a USB connection.

Multiple USB connection and AUX-IN connection

If the "Comfort" mobile phone interface is fitted in conjunction with the Composition Media radio or the Discover Media radio navigation system in the vehicle, it has two Apple-capable USB connections and one AUX-IN connection.

USB and AUX-IN connection

USB and AUX-IN connections are fitted externally on the Composition Media and Discover Media radios.

USB connection



S562_011

USB and AUX-IN connection



S562_012

The USB connections can also be ordered with support for Apple formats.

Switching of the multiple USB connection

The USB distributor R293 is used so that two data-capable USB connections can be operated. This makes it possible to connect two USB sockets to the USB connection of the control unit 1 for information electronics J794.

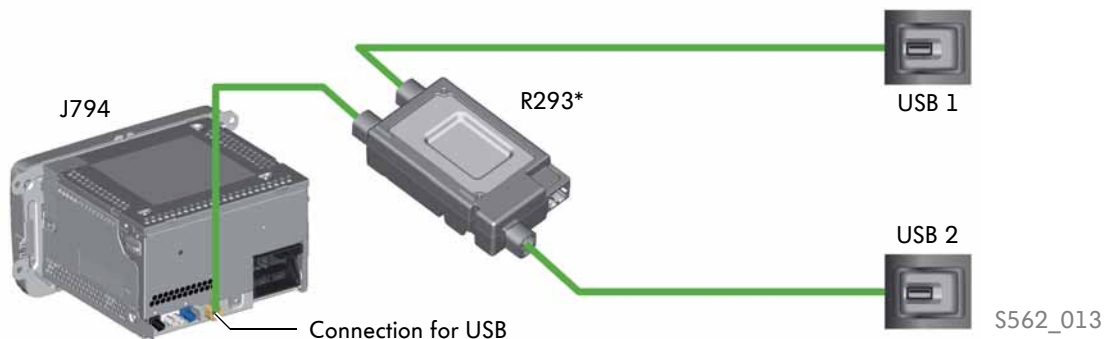

Legend

J794 Control unit 1 for information electronics
R293 USB distributor

* In this configuration, the Apple authentication chip is integrated in the USB distributor R293.

External media interfaces

Installation locations of the external media interfaces

Caddy 2016

In the storage compartment under the centre armrest



S562_015

In the compartment in front of the gear lever



S562_014

T6 2016 Multivan

In the compartment next to the gear lever



S562_017

In the glovebox



S562_016

T6 2016 Transporter

In the lower storage compartment ("measuring ruler compartment")



S562_030

In the upper storage compartment



S562_031

Mobile phone preparations

The mobile phone interface

Only one telephone can be paired via HFP in the Composition Audio and Composition Colour radios, whereas with Composition Media and Discover Media radios it is possible to pair two mobile phones simultaneously via HFP. The following Bluetooth protocols or profiles are supported: HFP, A2DP, AVRCP.



Connection possibilities

The table below shows the possible combinations for Composition Audio and Composition Colour radios.



Composition Audio radio

 Mobile phone 1
HFP
HFP + A2DP/AVRCP

Composition Colour radio

 Mobile phone 1	 Mobile phone 2
HFP	A2DP/AVRCP
HFP + A2DP/AVRCP	-

The possible combinations for the Composition Media and Discover Media radios are shown in the table below.

 Mobile phone 1	 Mobile phone 2
HFP (prioritised)	HFP (associated)
HFP (prioritised) + A2DP/AVRCP	HFP (associated)
HFP (prioritised)	HFP (associated) + A2DP/AVRCP



Button for changing over between two mobile phones

S562_032

Prioritised phone

The mobile phone that is paired first, or the one detected first after the terminal 15 on cycle, is identified as prioritised. A list of the maximum of two active mobile phones is displayed in the menu of the radio/navigation system.

Associated phone

If a mobile phone is already paired, or already detected in the active driving cycle, the next is identified as associated. It is shown in the menu list of the radio/navigation system as the second one below it.

Both mobile phones (prioritised and associated) have equal rights for incoming and outgoing calls. The mobile phone that initiates first is given precedence.

Mobile phone preparations

"Comfort" mobile phone interface

The "Comfort" mobile phone interface allows the best possible transmission and reception properties by a connection to the external aerial of the vehicle. The connection is made inductively and offers the opportunity of connecting a mobile telephone to the vehicle's aerial system without a physical plug-in connection. The "Comfort" mobile phone interface is available as an option with Composition Colour, Composition Media and Discover Media radios. The Composition Media and Discover Media radios then have an additional USB connection.

Storage compartment with mobile phone interface R265

The storage compartment with interface for mobile phone R265 is required for inductive coupling of the aerial of the mobile phone to the vehicle's outside aerial. In the Caddy 2106 it is located in front of the gear lever, and in the T6 2016 in the storage compartment next to the gear lever or in the upper storage compartment of the dash panel on the front passenger side.

Storage compartment in the T6 Multivan



S562_062

Storage compartment in the Caddy 2016



S562_019

2-way signal booster for mobile phone J984

In addition to inductive coupling of the mobile phone area in the storage compartment with interface for mobile phone 265, the aerial signal is boosted by the 2-way signal booster for mobile phone J984. This is connected in the signal line between the storage compartment with interface for mobile phone 265 and the telephone aerial R65 (GSM).

The 2-way signal booster is located on the holder of the onboard supply control unit in the Caddy 2016, while in the T6 2016 it is in the front left door.

"Comfort" system setup

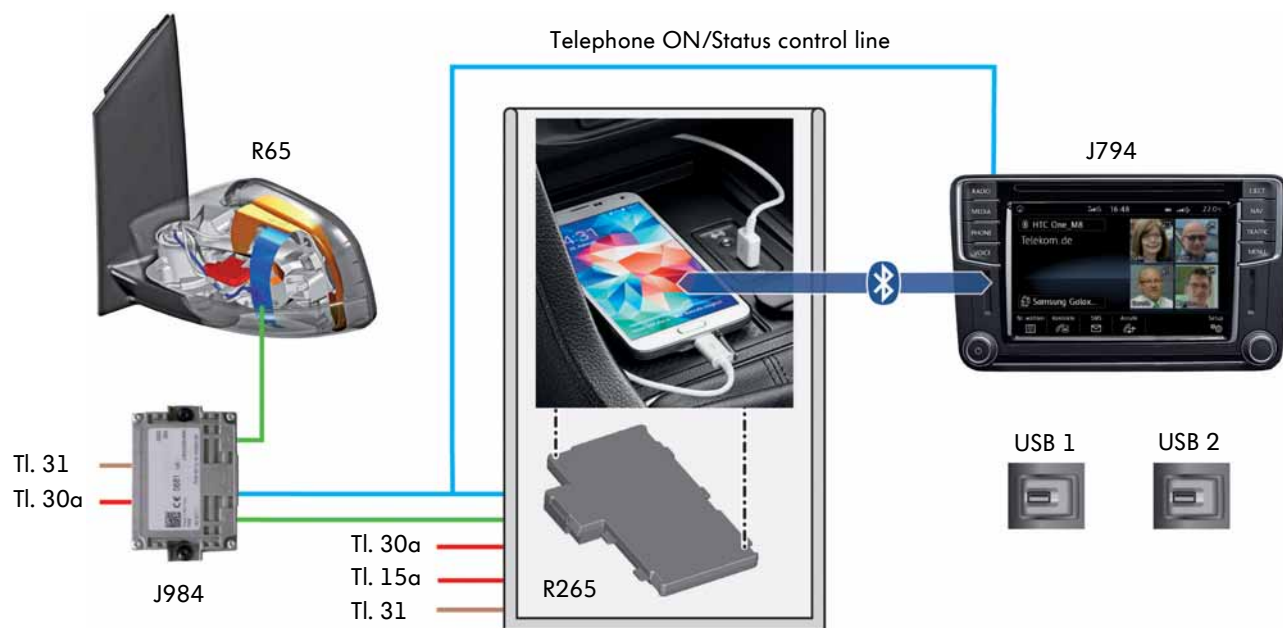

S562_020

Legend

J794 Control unit 1 for information electronics
 J984 2-way booster for mobile phone

R65 Phone aerial
 R265 Storage compartment with mobile phone interface

Internet connection

The preconditions

If the Discover Media radio navigation system is installed in the vehicle, it can be used for establishing a connection to the Internet.

The user can establish a connection between the vehicle and the Internet in the following ways:

- Car-Stick
- WLAN

Discover Media



S562_021

The Car-Stick

The Car-Stick is a USB stick with an integrated modem that can only be used in the vehicle; it is also referred to as a UMTS stick. After a SIM card has been inserted, the stick can be connected to a vacant USB connection in the vehicle.

The Internet connection is only established once the SIM card PIN has been entered. Data transfer between the Car-Stick and Discover Media radio navigation system takes place via the USB interface.



S562_022

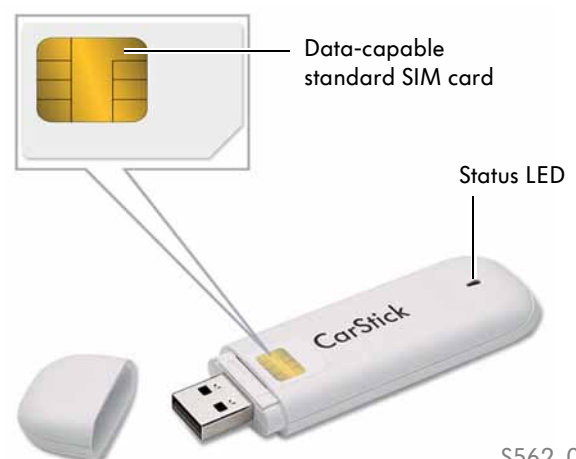

S562_023

The WLAN

The WLAN can be used in two different modes:

- The Discover Media radio navigation system is a client. Another device is the hotspot.
- The Discover Media radio navigation system operates as the hotspot. The connected devices are clients.

Discover Media radio navigation system as client

It is a prerequisite to have a terminal unit that generates a hotspot. This can be a local WLAN hotspot (e.g. in the customer's home network) or a mobile WLAN hotspot (e.g. WLAN hotspot of the customer's own smartphone).

Once the "WLAN" button has been pressed on the Discover Media radio navigation system, it is possible to select the corresponding hotspot of a device (in this example, a smartphone with Android operating system). The connection is established after the WLAN password has been entered.

The Discover Media radio-navigation system now functions as a client, and can establish an Internet connection to the Volkswagen Car-Net backend.

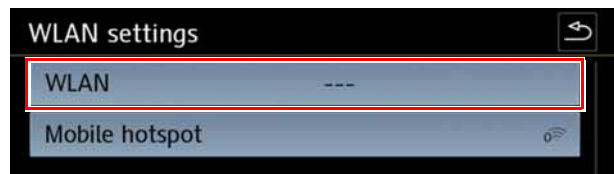

S562_024

Discover Media radio-navigation system as hotspot

If the Discover Media radio-navigation system should itself generate a mobile hotspot, the WLAN mode must be set to "Mobile Hotspot" in the WLAN settings. The internal WLAN module of the Discover Media radio navigation system now functions as a WLAN Hotspot. Up to eight other WLAN components can be linked to this hotspot.

In this case, it is a prerequisite for Internet access that the Discover Media radio navigation system must provide an Internet connection by use of the Car-Stick.

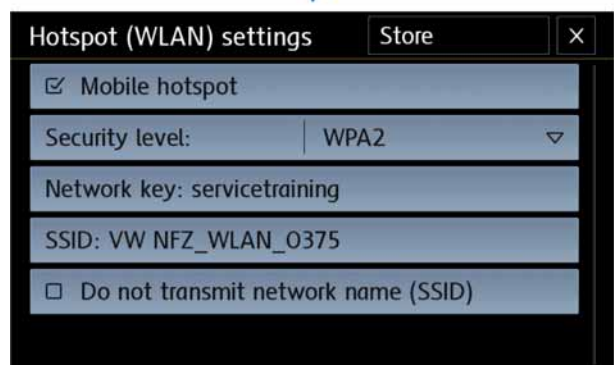
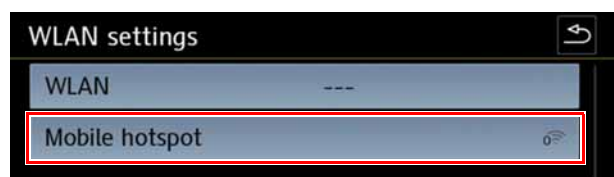

S562_025

Sound system

The "DYNAUDIO" digital sound system in the T6 2016

Optionally, the infotainment system can be equipped with the "DYNAUDIO" sound package in combination with the Composition Colour, Composition Media radios and Discover Media radio navigation system. The amplifier carefully adapts eleven treble, midrange and bass frequencies to one another, providing a full sound. The centre speaker makes the sound effect in the T6 2016 perfect.

The centre speaker is fitted in the middle of the dashboard top part. The storage compartment is deleted in that case.

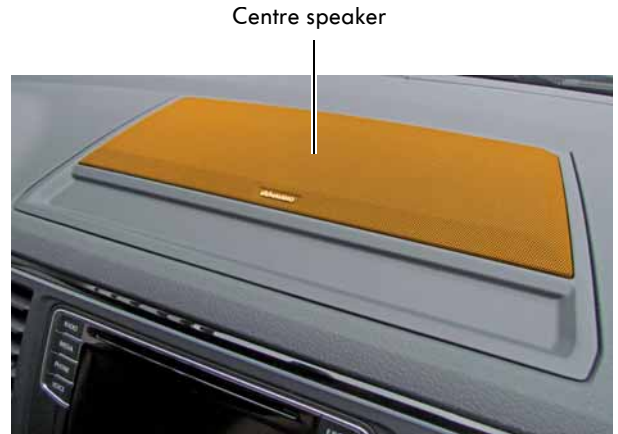

S562_027

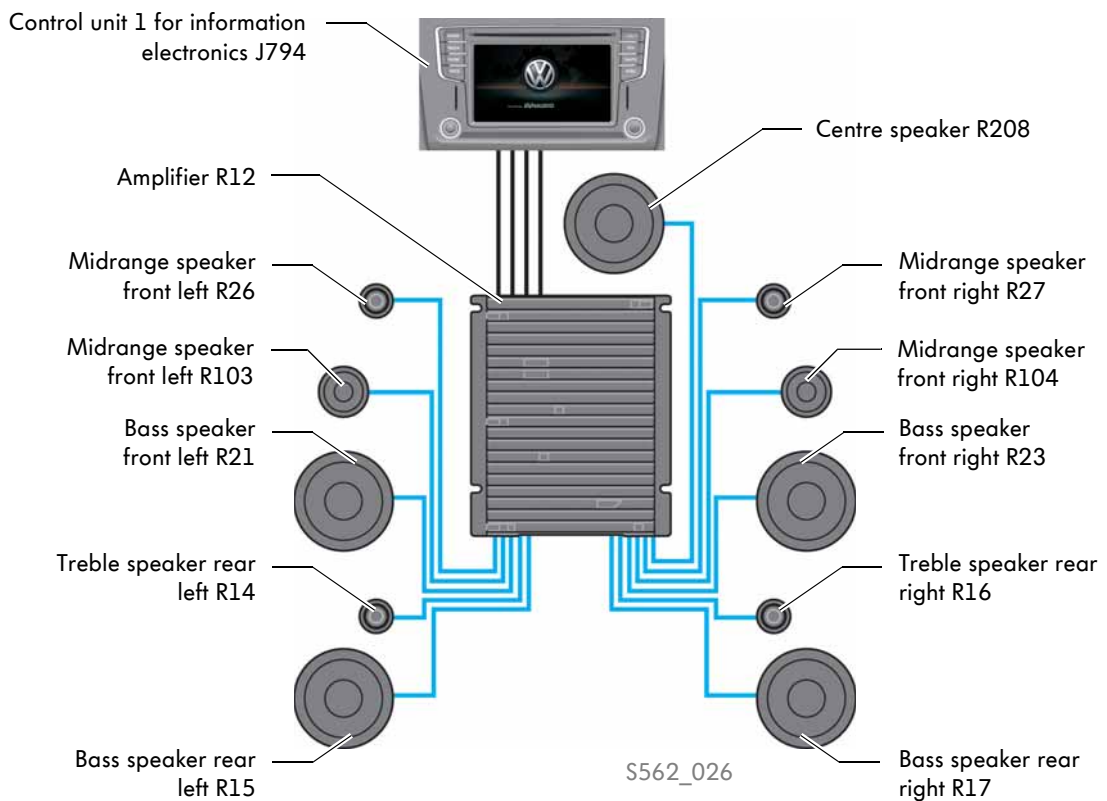

The aerial concept in the Caddy 2016

The Caddy 2016, both as the passenger car and commercial vehicle variant, features exterior mirrors with integrated vehicle aerals. In the commercial vehicle version, the arrangement and design correspond to the exterior mirrors used in the Caddy 2011.

The illustrations show exterior mirrors with the maximum possible range of vehicle equipment.

Passenger car version

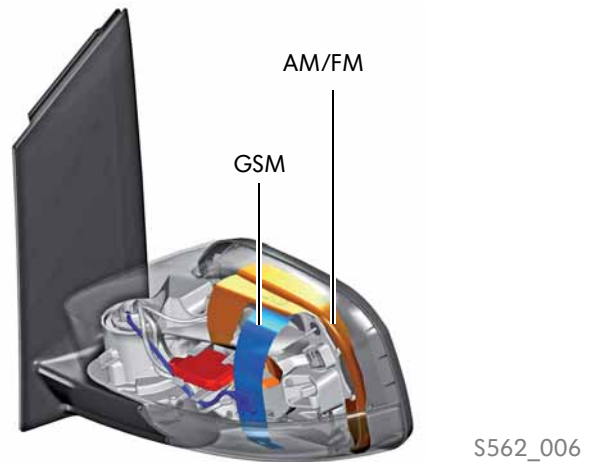
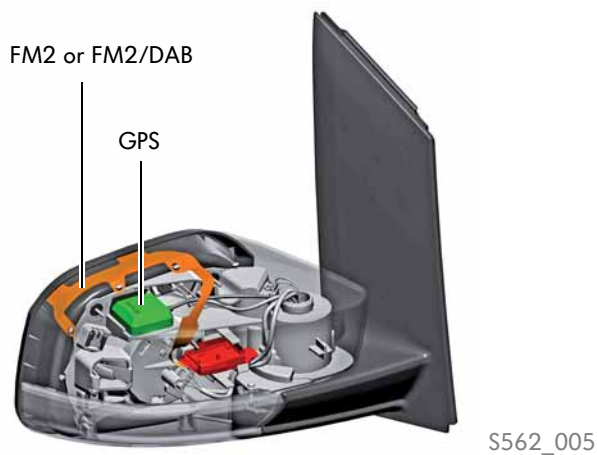

Commercial vehicle version

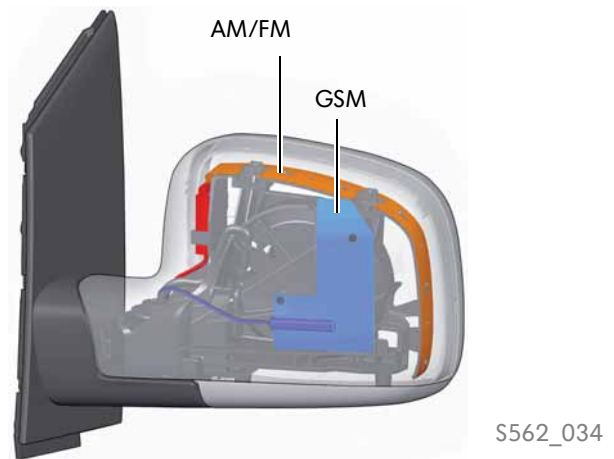
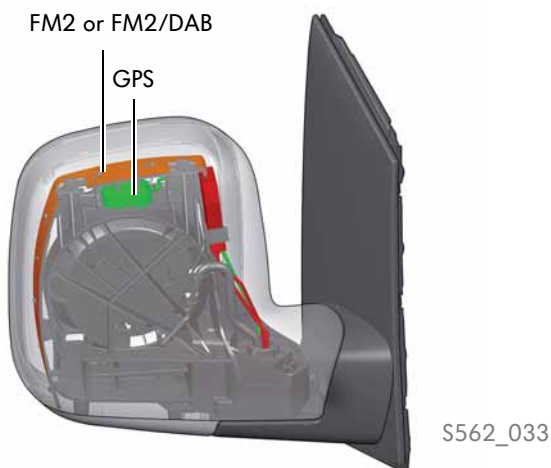

For more information about the aerals in the exterior mirrors, refer to Self-Study Programme no. 472 "The Caddy 2011".

Aerial concept

The aerial concept in the T6 2016

A complete aerial system is integrated in the exterior mirrors of the T6 2016 for the radio, telephone and GPS. In this case, the mirror versions vary between modular exterior mirrors and round bar mirrors, depending on the particular model version. The arrangement and design of both versions correspond to the exterior mirrors used in the T5 2010.

Closed bodies

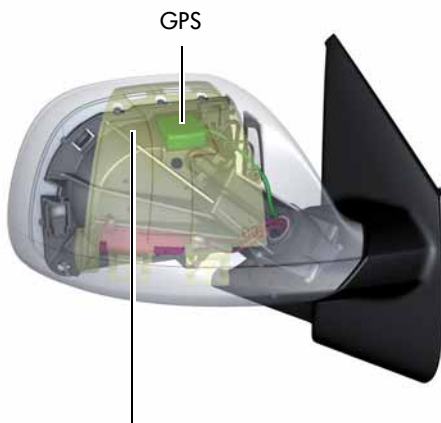

FM2 or FM2/DAB

S562_042

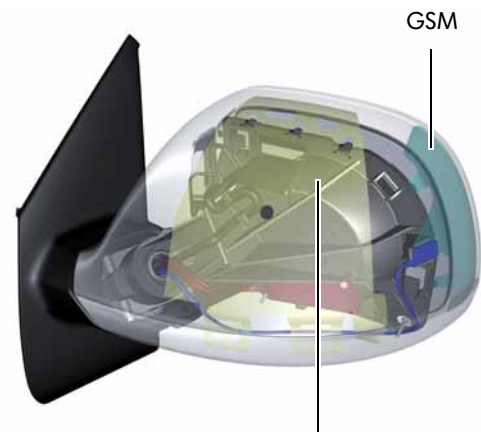

AM/FM

S562_043

Open bodies

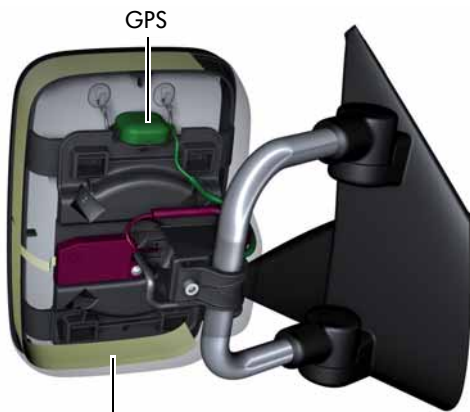

FM2 or FM2/DAB

S562_044

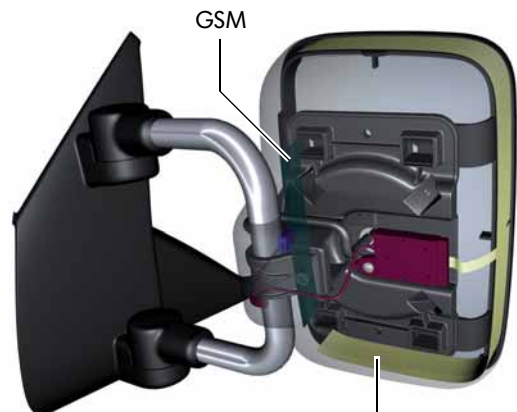

AM/FM

S562_045



For more information about the aerials in the exterior mirrors, refer to the self-study programme no. 453 "The T5 2010".

The Car-Net

For the first time, Volkswagen Commercial Vehicles is presenting mobile online services, also referred to as Car-Net. This involves using online data for certain applications, which are referred to as services. These can be provided for various application areas.

The following services are currently available:

Guide & Inform

Improved navigation and infotainment.



S562_070

App Connect

Smartphone connections and apps.



S562_039



S562_069



S562_072

The Car-Net App-Connect service

The App-Connect provides the customer with three interfaces for connecting a smartphone and the infotainment system:

- MirrorLink
- Android Auto
- Apple CarPlay

This new technology enables customers to display and operate selected parts of their smartphone on the touchscreen of the infotainment system.

App-Connect is available for the Composition Media radio and the Discover Media radio navigation system.



S562_039

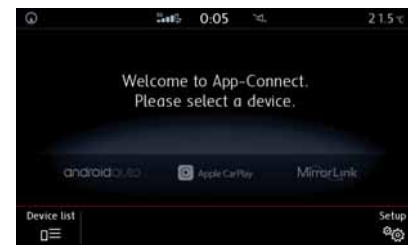

S562_040

MirrorLink

MirrorLink is a standard that is independent of the operating system. It enables smartphone content to be shown on the display of the infotainment system. MirrorLink was developed by the "Car Connectivity Consortium" (CCC). Several vehicle, smartphone and infotainment system manufacturers belong to this organisation. At the present time, MirrorLink is only supported by smartphones with Android operating systems. This standard makes it possible to show apps on the display of the infotainment system even when driving. The precondition is for the app in question to be approved by the CCC.

The smartphone is connected to the vehicle using a USB data cable. Only image and music data is transferred via the data cable. The smartphone must additionally be paired using Bluetooth in order to use the hands-free function in the vehicle. The smartphone must have an Internet connection so that MirrorLink can function correctly. Only then can the certificates of the apps be downloaded, enabling the system to display the apps even during driving.

If the Android smartphone supports both MirrorLink and Android Auto, the required or preferred service must be selected in the Setup menu of the Composition Media radio or the Discover Media radio navigation system.



S562_041

Structure of the MirrorLink display



Legend

- 1 Disconnect MirrorLink connection
- 2 Shutdown active apps
- 3 Activate mirroring
- 4 Display area of all MirrorLink-compatible apps that are installed on the smartphone
- 5 Setup menu of the infotainment system





S562_046

Prerequisites

- MirrorLink-capable smartphone (currently only available for the Android operating system)
- Connection of the smartphone to the vehicle via USB data cable
- Approval of the app by the "Car Connectivity Consortium"

Apps

MirrorLink-compatible apps can be downloaded from the "Google Play Store". Apps are offered here directly from Volkswagen and by third parties. Currently, Volkswagen Commercial Vehicles offers four MirrorLink apps for downloading:

Logo	App name	Description
	My Guide	Point of interest search performed by the app. Route guidance in this case is "directly to the door".
	Drive & Track	The app records the route travelled via GPS. During recording, the app automatically creates information points.
	Shared Audio	The app creates a complete playlist from all music files available on the network (WLAN in the vehicle). It is a precondition that all devices must be connected to the WLAN, and that the app is installed on all devices.
	Call & Remind	To-do and call lists can be created in this app. These can be processed if the traffic situation permits.



For more information about MirrorLink, please refer to Self-Study Programme no. 546 "The Passat 2015 infotainment and Car-Net".

Android Auto

Android Auto is a standard developed and managed by Google. This standard makes it possible to connect a smartphone to the infotainment system. This means the smartphone can be controlled using the vehicle's touchscreen. Android Auto displays the interactive "Google Now" interface on the infotainment system. Various information items are displayed on the start screen depending on how the user has configured his/her smartphone, and what location requests he/she has made. The information displayed is:

- Weather
- Navigation
- Missed calls
- Text messages
- E-mails
- Current music playback

The first connection can only be carried out at a standstill, because some system messages have to be confirmed. In addition to the cable connection, a Bluetooth connection is established automatically for the hands-free function. Any existing Bluetooth connections between other devices and the vehicle are dropped.

Structure of the Android Auto display



S562_047

Legend

- 1 Status (reception, battery, time)
- 2 Button for Google voice commands*
- 3 Button for navigation
- 4 Button for telephone
- 5 Button for the start screen
- 6 Button for music
- 7 Button for App-Connect menu

* The voice dialog can also be started by a long press of the voice control button on the multifunction steering wheel.

Prerequisites

- Android smartphone with Android operating system version 5.0 (Lollipop) or later
- Connection of the vehicle and smartphone via USB data cable
- The first connection must be made when the vehicle is stationary.
- Country approval and approval of the apps and smartphones must be undertaken by Google.

Apple CarPlay

Apple CarPlay is a standard defined by Apple making it possible to connect an iPhone to the infotainment system. If there is an existing connection, the iPhone can be operated using the touchscreen of the infotainment system, and also continue to be used normally. Apps that are started using the infotainment system are run on the smartphone and can be viewed. Displayed apps are:

- Telephone
- Music
- Maps
- News
- Current music playback (you are listening)
- Volkswagen
- Podcast
- Audio books

The connection is made using an iPhone-specific USB data and charging cable that is connected to the iPhone and the USB socket in the vehicle. Apple CarPlay is started automatically when the "Siri" voice assistant is activated in the iPhone settings. The entire data transfer and voice transfer for the hands-free function takes place via the data cable. All Bluetooth connections already existing to the vehicle are dropped.

Structure of the Apple CarPlay display

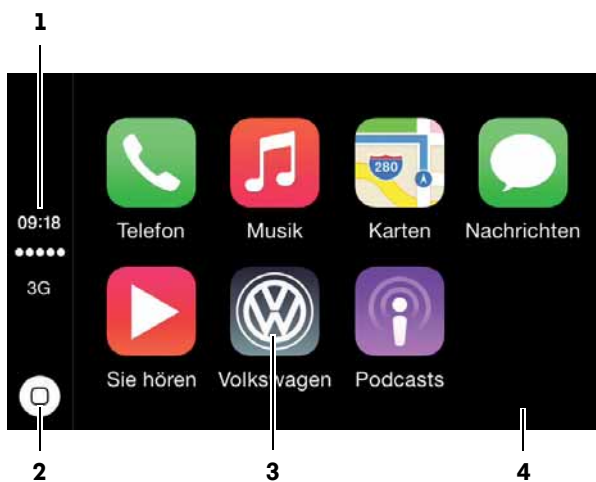

S562_048

Legend

- 1 Status (time, reception, reception type [mobile phone, W-LAN])
- 2 Button for start screen, Voice commands for "Siri" (long press)*
- 3 Button for App-Connect menu
- 4 Display area of CarPlay-capable apps

* The voice dialog can also be started by a long press of the voice control button on the multifunction steering wheel.

Prerequisites

- Can be used from iPhone onwards with operating system iOS version 8.0 or later
- Connection via USB data cable to USB 1 socket
- "Siri" must be activated.
- Country approval and approval of the apps must be undertaken by Apple.

The Car-Net Guide & Inform service

In order for Car-Net "Guide & Inform" to be used, it is necessary for the Discover Media radio navigation system to be fitted. The Guide & Inform services exclusively function if a connection has been established between the vehicle and the Internet. Furthermore, the customer must be registered with the vehicle on the customer portal.

Registration on the customer portal

The Car-Net information page is available at www.volkswagen-commercial-vehicles-carnet.com. The customer is redirected from this page to the customer portal.

The customer can use the following functions in this portal:

- Create a user account
- Vehicle registration
- Vehicle management
- Configure portal services

Step 1:

The customer registers using his/her personal data. Following that, he/she receives an e-mail with a confirmation link. Clicking this link completes the process of creating the user account.



Step 2:

The customer enters the vehicle identification number (VIN) of the vehicle in the input screen of his/her user account, and confirms the general terms and conditions and data protection provisions.



Step 3:

The customer is given an 8-digit registration code.



Step 4:

The customer establishes an Internet connection in the vehicle, and enters the registration code in the radio navigation system at the following path: MENU - Setup - Car-Net - Registration



s562_049

Services

The services offered can be divided into the following two categories:

- Non-portal services
- Portal services

At present, the following services are offered in these two categories:

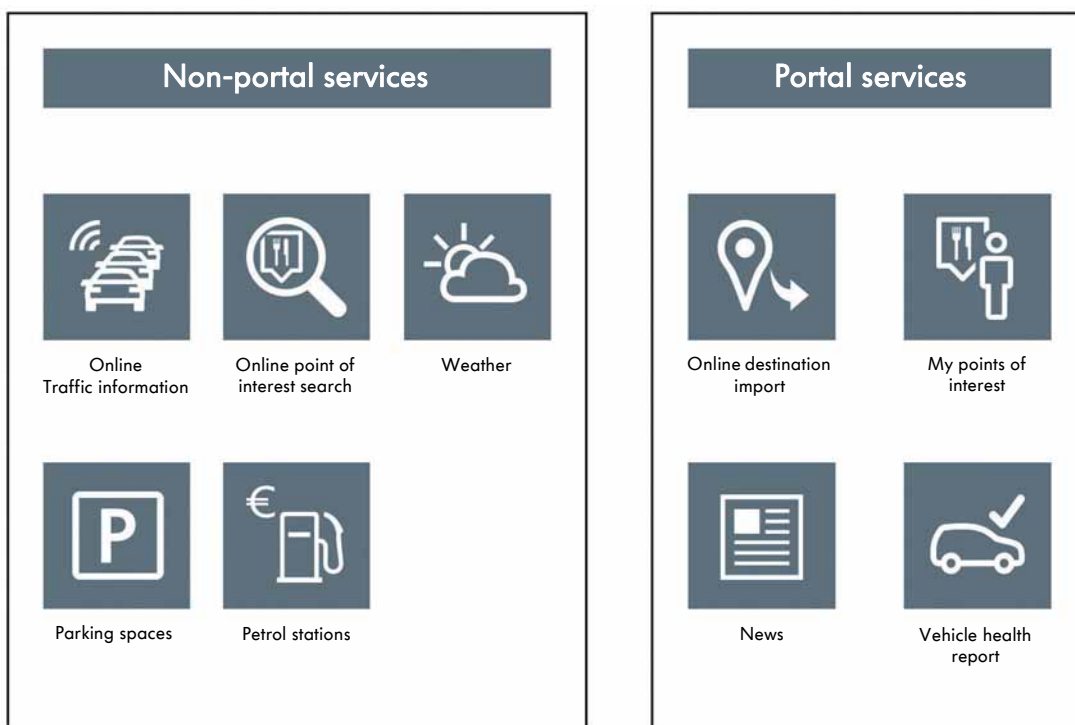

Non-portal services

These services can be used directly following successful registration on the customer portal using the Car-Net menu of the Discover Media. No further configuration or settings are required. The online traffic information can be selected in the main menu or using the Traffic key.

Portal services

Portal services require active configuration or interaction with the customer portal. For example, defining which personal POIs should subsequently be available in the vehicle. Following that, they are sent to the vehicle online.



Not all services are available in each country. For more information about country availability, refer to www.volkswagen-commercial-vehicles-carnet.com.

Non-portal services

Online traffic information

Traffic information is displayed as a traffic message in the form of a list under the "TRAFFIC" heading, and if relevant as traffic flow animation on the navigation map in colour. Anonymised position information of the vehicle is transmitted at regular intervals in encrypted format to the traffic data provider, where it is processed further. The traffic information provided is created on the basis of the latest information available from the traffic data provider, TomTom. The world symbol or Car-Net identification shows that the displayed messages are online traffic information. Without a connection to the Internet, only the TMC traffic messages are displayed. Compared with TMC, the main advantages of online traffic information concern the shorter update rates and greater depth of information.

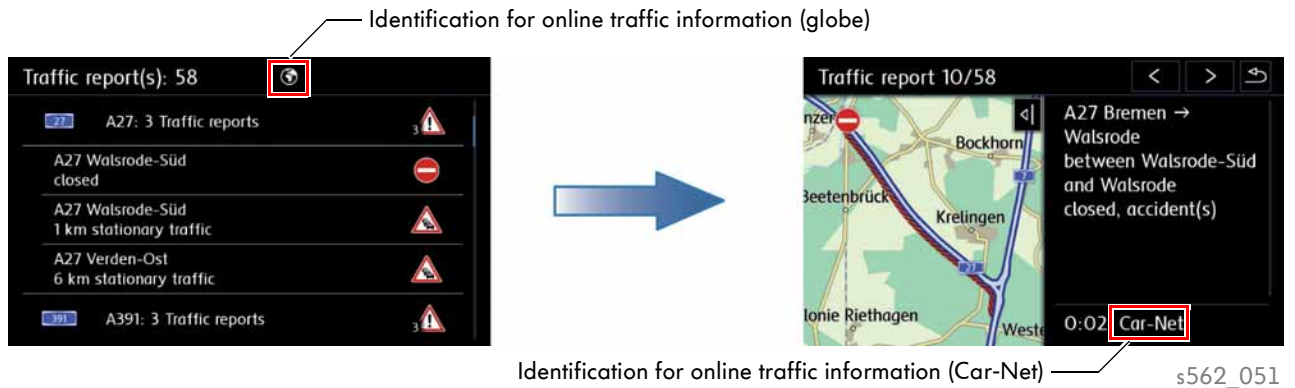

Online point of interest search

The online point of interest search is made by the customer directly in the vehicle. It expands the conventional point of interest search. The search request is processed on the basis of the latest information provided by Google. The customer can select a destination from the points of interest found. These can be saved as navigation destinations, or contacted by telephone. This service helps to improve searching for a point of interest, or indeed to make the search possible in the first place. The enquiry only delivers results for the areas/countries in which the service is available.

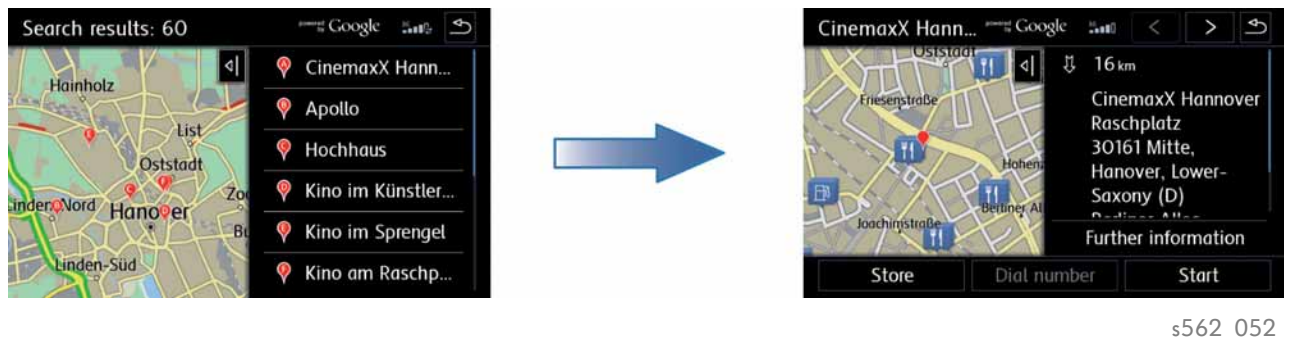

Weather

With this service, various weather data can be displayed in the vicinity of the vehicle's location and the destination. The user can display the following data:

- Current weather at the vehicle's location and destination
- 24-hour weather forecast
- 3-day weather forecast
- Precipitation radar

The data is provided by the "MeteoGroup" weather data provider.



s562_053

Parking spaces

This system assists the driver in searching for a parking space. The total capacity and current occupancy of multi-storey car parks and parking facilities offering this service are displayed. If available, additional information is shown regarding prices, opening times and infrastructure. The driver is guided directly to the parking space using the navigation system. The data is provided by the "INRIX" data provider.



s562_054

Car-Net

Petrol stations

This service shows the fuel prices at service stations in the vicinity. Navigation to the corresponding filling station can be started directly. The display is for the specific fuel type. This means the fuel type required by the vehicle is displayed. Furthermore, the following information is displayed:

- Address of the filling station
- Phone number of the filling station
- Time of the last update
- Prices of all fuels available
- Sorting by price or distance

The data is provided by the "INRIX" data provider.

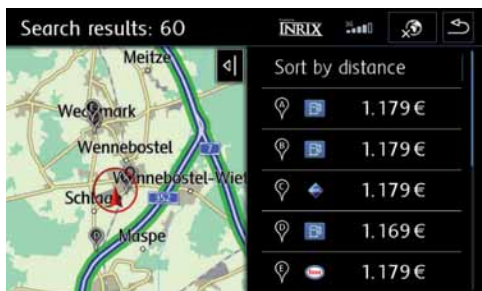

s562_055



The data providers of the individual services can change at any time. Which data providers are currently providing the data can be seen using the "Car-Net Info" button in the "Usage conditions" menu.

Portal services

In the customer portal, the user has the opportunity to configure and use the following services:

- Online destination import
- News
- My points of interest
- Vehicle health report

The screenshot displays the Volkswagen Car-Net customer portal. At the top, a navigation bar (1) includes 'Home' and 'My Transporter'. The main content area features a personalized welcome message for 'John Smith' and a red Volkswagen Transporter. Below this, vehicle data (2) is listed: Model type: Transporter, VIN: WVZZZ7HZGH000XVZ, term of contract: active until 09 June 2016, and Registration code: 35732197. A central section (3) highlights four services: 'Online destination import' (convenient planning), 'Vehicle health report' (service check), 'My points of interest' (personalized destinations), and 'News' (information feeds). The footer (4) contains links for 'Volkswagen 2015', 'Main Benutzerkonto', 'Infocenter', 'Häufig gestellte Fragen (FAQ)', 'Kontakt', 'Impressum', 'Rechtliches', 'Volkswagen Car-Net', 'Volkswagen Deutschland', 'Volkswagen AG', 'Händleruche', 'Volkswagen Nutzfahrzeuge', and 'Händleruche (Austofahrtzeuge)'. The identifier 's562_056' is located in the bottom right corner.

Legend

- | | |
|---|---|
| <p>1 Menu bar</p> <p>2 Vehicle data and contract term</p> | <p>3 Services that can be run</p> <p>4 FAQs, publisher's information, information centre, contact</p> |
|---|---|

Car-Net

Online destination import

The online destination import enables the user to search for a destination on the customer portal via Google Maps, and then send this to the vehicle as an online destination. When the Internet connection is established in the vehicle, the online destinations are updated automatically. If online destinations should be sent from the customer portal when there is already an Internet connection established to the vehicle, they can be called up manually using the "Update" button.

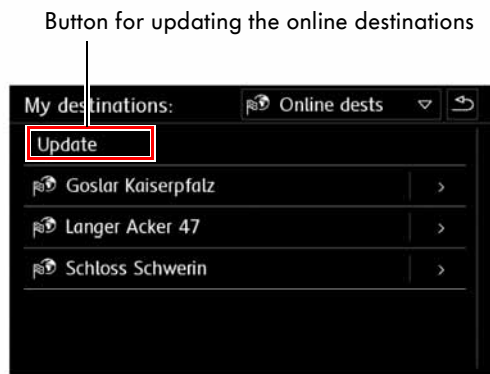
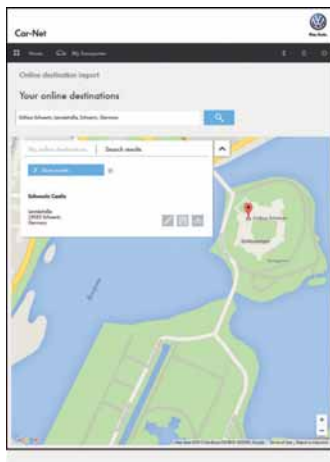

s562_057

My points of interest

This service enables the user to send downloaded files containing POI destinations online to the vehicle. On the Internet, there are POI databases available for download. The customer can temporarily store this data on his/her computer and subsequently upload it to the customer portal. As soon as the vehicle has established an Internet connection, the user can start the download of data using the "Car-Net" menu and the "Download" button. If a list contains more than 200 entries, the 200 closest entries are always displayed. Up to 50 lists can be uploaded.

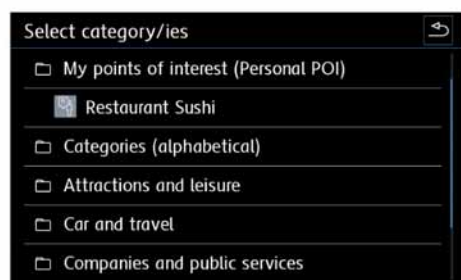
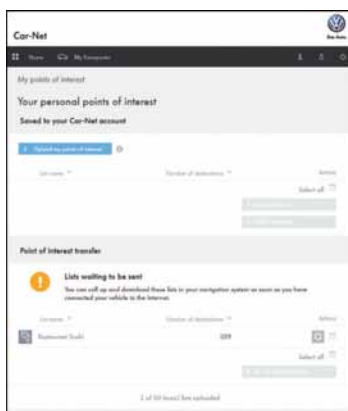

s562_058

News

Using this service, the user can load RSS feeds ("really simple syndication") into the vehicle's system. RSS feeds are entered as URL links in the dialog box on the customer portal. If the entry is valid, the name of the RSS feed appears next to the entry box. Following saving, the RSS feed is stored in the customer portal and can be subscribed to, so it is sent to the vehicle. Up to 10 feeds can be displayed in the vehicle.

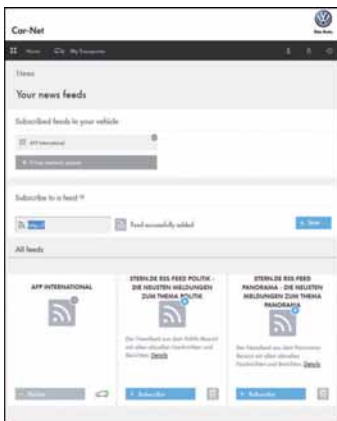

s562_059

Vehicle health report*

The user can check the status of the vehicle online using the vehicle status report. The vehicle health report is generated in the vehicle at regular intervals of time or mileage, and called up at the customer's request. The report is transferred from the vehicle to the system when an Internet connection is established, and is available to the customer portal. The report contains information about monitoring and warning messages on the dash panel insert.

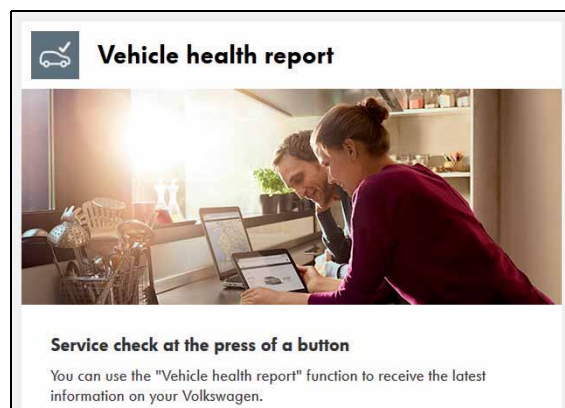

s562_060

* At the time this Self-Study programme was written, the availability and scope of the service had not yet been defined.

The Service portlet

The Service portlet is an application that functions as a system monitor for identifying the causes of problems in the connection to mobile online services. It can provide assistance during diagnosis so as to avoid unnecessary visits to the workshop. The following data can be called up and displayed via the Service portlet:

The screenshot shows the Volkswagen Service portlet interface. It includes a search bar for customer data, a table for vehicle details, and sections for services and backend status. Numbered callouts (1-7) point to specific areas of the interface.

Section	Item	Status
1-4: Customer and Vehicle Data	VIN	WV2ZZZ7HZGH000XYZ
	Model name	Multivan High.sw150 TDI7at
	Model year	2016
	Colour	Deep Black Pearlescent
	Country	Germany
	Head unit installed	✓
	Telematic capability	✓
	App-Connect available	✓
	Navigation system included	✓
	Navigation system	Navigation system MIB2 Standard PQ (EU/ROW)
5: Services	Booking status	✓
	Availability for the vehicle	✓
6: Backend status	Backend available	✓
	Detailed description	Backend is available.
7: Compatibility list	Optional market-specific links to compatibility lists of mobile phones and preparations for mobile phones	

s562_061

Legend

- 1** Input screen
- 2** Customer data
 - Personal details
 - Data protection consents
- 3** Contract data
 - Contract status
 - Expiry data
- 4** Vehicle data
 - General vehicle data
 - App-Connect availability
- 5** Status of services
 - Booking status
 - Availability for the vehicle
 - Service status
- 6** Backend status
 - Availability of the Volkswagen backend
- 7** Compatibility
 - Optional market-specific links to compatibility lists of mobile phones and preparations for mobile phones



Glossary

AAC

(Advanced Audio Coding)

AAC is an audio data compression process developed by the Moving Pictures Expert Group that uses the MP2 standard (MPEG Layer 2).

AM

Amplitude modulation, electromagnetic wave used for carrying messages.

In amplitude modulation, the amplitude of the high frequency is changed.

AUX-IN

(Auxiliary In)

Signal input for external audio devices.

AVRCP

(Audio Video Remote Control Profile)

Bluetooth profile for remote control of audio or video devices.

A2DP

(Advanced Audio Distribution Profile)

Non-proprietary technology that enables stereo audio signals to be sent wirelessly via Bluetooth to a corresponding device.

Bluetooth

Bluetooth is an industry standard developed by the Bluetooth Special Interest Group (SIG) for radio transmission between devices over short distances.

DAB

(Digital Audio Broadcasting)

Radio programme broadcast digitally by radio stations.

DAB+

(Digital Audio Broadcasting Plus)

Further development of the digital radio that was introduced in Germany in 2011 under the name DAB+.

FAQ

(Frequently Asked Questions)

Frequently asked questions.

FLAC

(Free Lossless Audio Codec)

Audio codec for lossless audio data compression.

FM

Frequency modulation, electromagnetic wave used for transferring messages.

In frequency modulation, the frequency of the carrier wave varies according to the rhythm of the information voltage. The amplitude remains constant.

FM phase diversity

Necessary function in the radio and navigation system for permitting two-tuner operation.

GPS

Global Positioning System
Officially NAVSTAR GPS, a global navigation satellite system for determining position and measuring time.

GSM

(Global System for Mobile Communications)
Standard for digital mobile networks that is chiefly used for telephony, as well as data transfer and short messages (SMS).

HFP

(Hands-Free Profile)
Standard Bluetooth profile that permits communication between the mobile phone and vehicle hands-free system.

Hotspot

The term hotspot is frequently used to refer to a public access point to the Internet. At a hotspot, it is possible to connect to the Internet wirelessly.

MAP

(Message Access Profile)
Makes it possible to read and write SMS messages.

MIB

(Modular infotainment system)
Term for a non-proprietary and cross-model modular system for the infotainment components of a vehicle.

MP3

Short form of MPEG Layer 3 (Motion Picture Experts Group Layer 3); compression standard for audio data formats.

PBAP

(Phone Book Access Profile)
Bluetooth profile that permits access to the phone book of the mobile phone.

Personal POI

(POI = Point of Interest)
A personal POI is a point of interest that has been transferred to the infotainment device additionally by the driver. Several personal POIs can be combined in one POI package, which can then contain the position data of many points of interest. POIs in different categories can be placed in the package. An icon (small symbol) can be assigned to the categories, and is then displayed in the map view of the navigation system.

POI online search

(POI = Point of Interest)
Information about an interesting navigation point in the navigation and route planning.

RSS

(Really Simple Syndication)
Standardised data format for structured publishing of changes to Internet pages.

Glossary

SD card

(Secure Digital Card)

Small and robust memory cards, e.g. for digital cameras.

SIM

(Subscriber Identity Module)

Chipcard that is inserted in a mobile phone and identifies the user on the network.

TFT

(Thin Film Transistor)

Abbreviation for a flat screen with transistor display matrix.

TMC

(Traffic Message Channel)

Transfer of traffic information using FM frequencies to permit dynamic route guidance.

UMTS

(Universal Mobile Telecommunications Systems)

Third generation mobile phone standard enabling data transfer rates of up to 42 Mbit per second.

URL

(Uniform Resource Locator)

Unique identification or address of a resource on the Internet, for example a website.

USB

(Universal Serial Bus)

Serial bus system for connecting the computer to external devices during ongoing operation, with automatic detection.

WLAN

(Wireless Local Area Network)

Wireless local network that is used for establishing a connection to the Internet.

WMA

(Windows Media Audio)

Special audio format under Microsoft Windows.



562



© VOLKSWAGEN AG, Wolfsburg
All rights reserved. Subject to technical modifications.
000.2813.19.20 Technical status 10/2015

Volkswagen AG
Volkswagen Commercial Vehicles
Vertrieb After Sales NV-K/K
Brieffach 2940
D-30405 Hannover

♻️ This paper was manufactured using pulp bleached without the use of chlorine.