



Self-Study Programme 519

The Infotainment System in the Golf 2013 Part II

Design and Function



Consumers want to be able to access the wealth of information on the Internet easily and conveniently from their own vehicles. This requires increasingly complex and higher performance networking structures. This is accomplished by connecting the various functions and functional units in the vehicle to new system components, such as the vehicle's WLAN or the new mobile online service. As more more information is being handled and transmitted, efficient transmission paths are essential. It is therefore not surprising that for certain areas in the modular infotainment matrix (MIB) greater use is made of fibre optic technology for internal data transmission in the infotainment system (e.g. in the MOST data bus).

Another customer request concerns matching the character of the vehicle to driver preferences. For this reason the driver profiles that were supplied with the Golf 2013 when it was launched on the market need to be constantly expanded and developed. All of these issues result in more comprehensive networking of the various vehicle systems.

All areas concerned with infotainment continue to be exciting. In this booklet we would like to introduce you to current developments, using the Golf 2013 and Golf GTI/GTD 2013 as an examples.



The self-study programme describes the design and function of new developments. The contents will not be updated.

For current testing, adjustment and repair instructions, refer to the relevant service literature.



Important Note



| | |
|---|-----------|
| Introduction | 4 |
| What's new? | 4 |
| Networking concept | 6 |
| The MOST150 data bus | 6 |
| The aerial systems | 10 |
| Telephone preparations | 12 |
| Overview of the mobile telephone preparations | 12 |
| The "Comfort" mobile telephone interface | 13 |
| The "Premium" mobile telephone interface | 15 |
| Driving profiles | 18 |
| The driving profile selection in the Golf 2013 | 18 |
| Sound system | 20 |
| The high-end sound system "DYNAUDIO Excite" | 20 |
| Service | 26 |
| Diagnostics and working on the MOST150 data bus | 26 |
| Updating navigation data | 27 |
| Glossary | 28 |
| Test your knowledge | 30 |

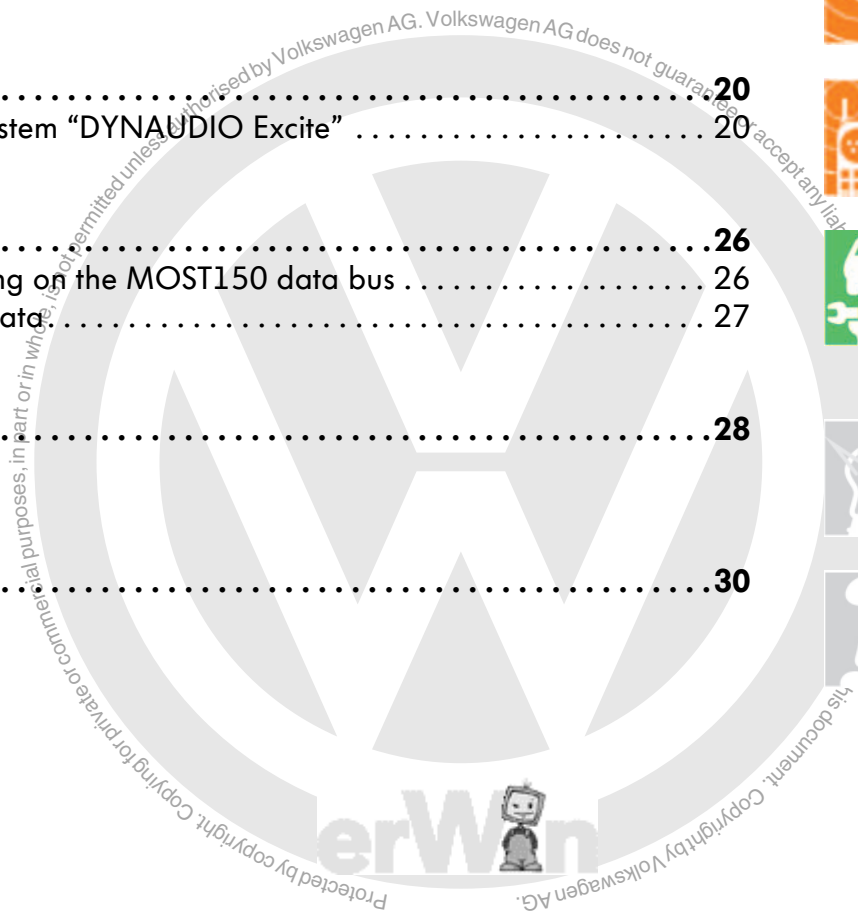

Introduction

What's new?

The MOST150 data bus

MOST stands for "Media Oriented Systems Transport" and is a standard for multimedia and infotainment networking in the auto industry. MOST is a protocol for fast transmission of multimedia data, especially image, video and audio data.

The universal basic principle of the protocol enables the connection of simple, robust devices.

A fibre optic cable for data transmission is often used for the MOST data bus. The biggest advantage of the MOST technology is the standardised interfaces, the transmitter and reception units (Fibre Optic Transmitter - FOT).

They make it possible to connect a variety of multimedia devices to the ring network structure. Compared to the MOST25, the new MOST150 data bus is characterised by a much greater bandwidth when it comes to data transmission. With 3072 bits per transmission unit (frame) the bandwidth is six times that of the MOST25. Further information about the MOST150 data bus can be found beginning on page 6.

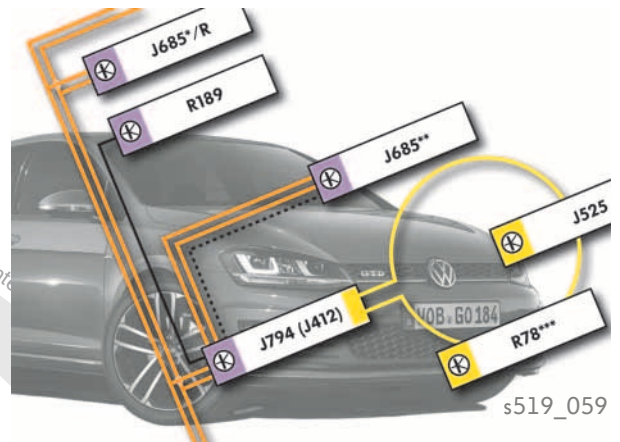

WLAN integrated into the vehicle

WLAN stands for "Wireless Local Area Network" and allows various devices (e.g. handhelds, smartphones, tablet PCs, and laptops) to log on and exchange data, as well as providing secure access to the Internet via the network. This means that a vehicle with a WLAN has its own access point (hotspot). The availability of such a hotspot is currently linked to the "Premium" mobile telephone interface.

Further information about this topic can be found beginning on page 15.



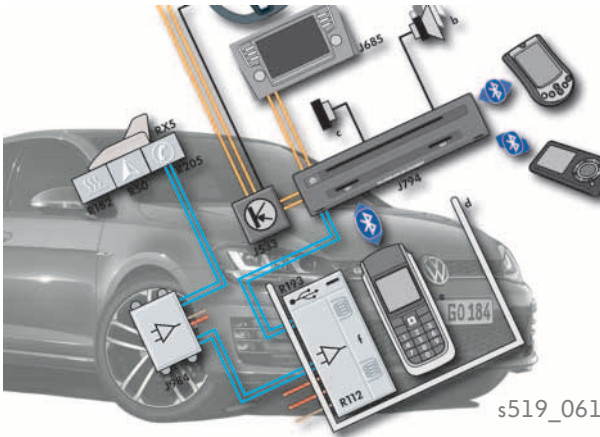

The “Comfort” and “Premium” mobile telephone interfaces

A key feature of the mobile telephone interface is the new storage compartment with interface for mobile telephone R265 (pairing box) in the centre console. It is a component of the “Comfort” mobile telephone interface. Among other things, the pairing box lets you connect a smartphone to the aerial system of the vehicle without a physical connector. An rSAP connection is possible with the “Premium” mobile telephone interface. Further information can be found beginning on page 12.

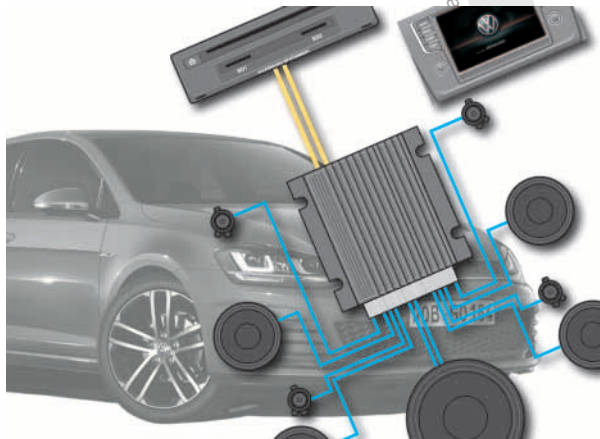

The high-end sound system “DYNAUDIO Excite”

The high-end sound system “DYNAUDIO Excite” has been adapted even better to the conditions of a vehicle. A tangible feature is the new subwoofer in the spare wheel well that contributes significantly to the sound quality of the sound system. Further information about the high-end sound system “DYNAUDIO Excite” can be found beginning on page 20.

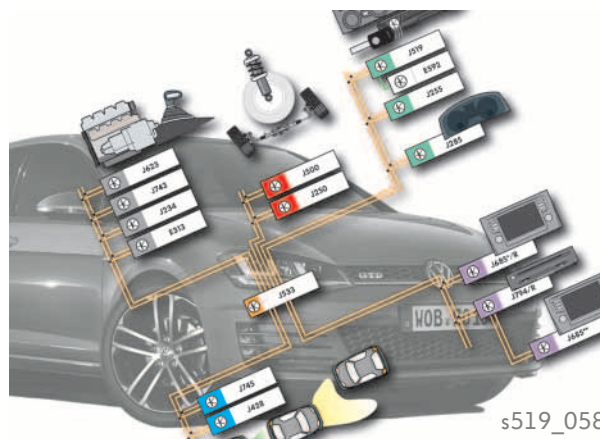

Driving profile selection

The driving profile selection was specifically adapted to the special character of the Golf GTI/GTD 2013. For example, the various driving profiles adjust the sound volume of the standard fitted actuator for structure-borne sound R214 to the driving situation. A comparison of driving profiles can be found beginning on page 18.

Networking concept

The MOST150 data bus

Volkswagen has used the optical MOST150 data bus in the Golf GTI/GTD 2013. The MOST150 is an enhancement of the MOST25.

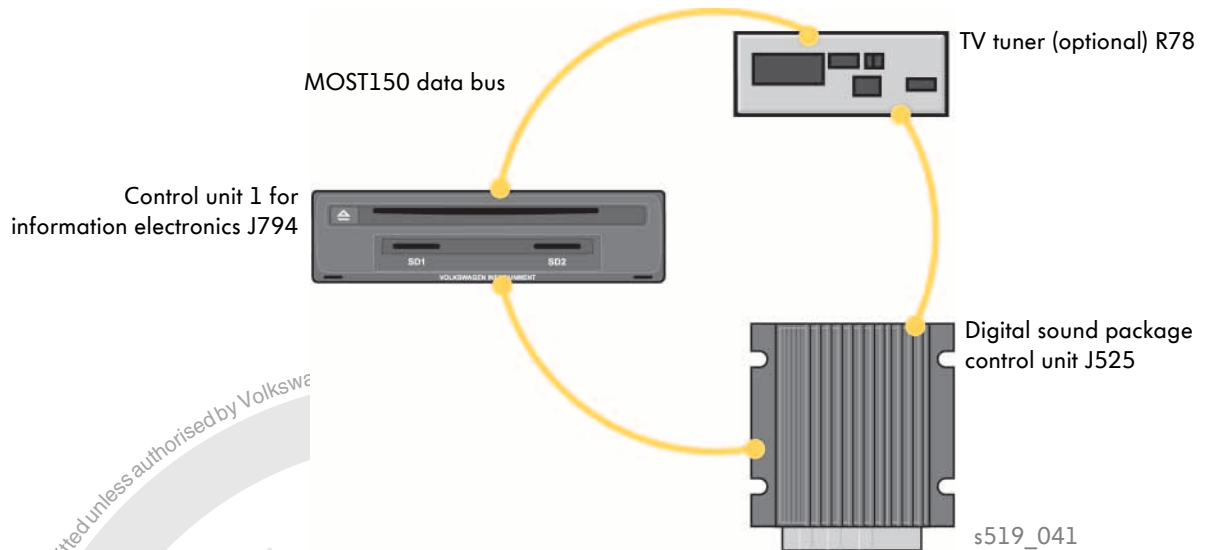

MOST means “Media Oriented System Transport”. It is a serial bus system for transmitting audio, video, speech and data signals, using fibre optic cables. MOST has a ring network structure that can include up to 64 MOST devices.

The MOST150 data bus in the Golf 2013 model launch has the following features:

- Data transfer rate: 150 Mbit/s (3072 bits per transmission unit)
- Ring topology with up to three participants
- Cyclical and event-driven data transfer
- High level of interference immunity to electromagnetic influences

The exchange of data between the participating components takes place digitally on the optical MOST150 data bus. The data transmission with fibre optic cable is significantly faster. Compared to radio waves, fibre optics use very short wavelengths. They do not create electromagnetic interference waves and are not sensitive to external electromagnetic influences.



Control unit 1 for information electronics J794 is the system and diagnostic manager for the MOST150 data bus.

Further information about diagnostics (e.g. ring circuit break diagnostics) can be found in Self-study Programme no. 473 “Infotainment in the Touareg 2011”.

Networking infotainment and MOST150 data bus

The following diagram shows the new features of the control unit network in the infotainment of the Golf GTI/GTD 2013. All CAN data bus systems in the Golf GTI/GTD 2013 have a transmission speed of 500 kbit/s.

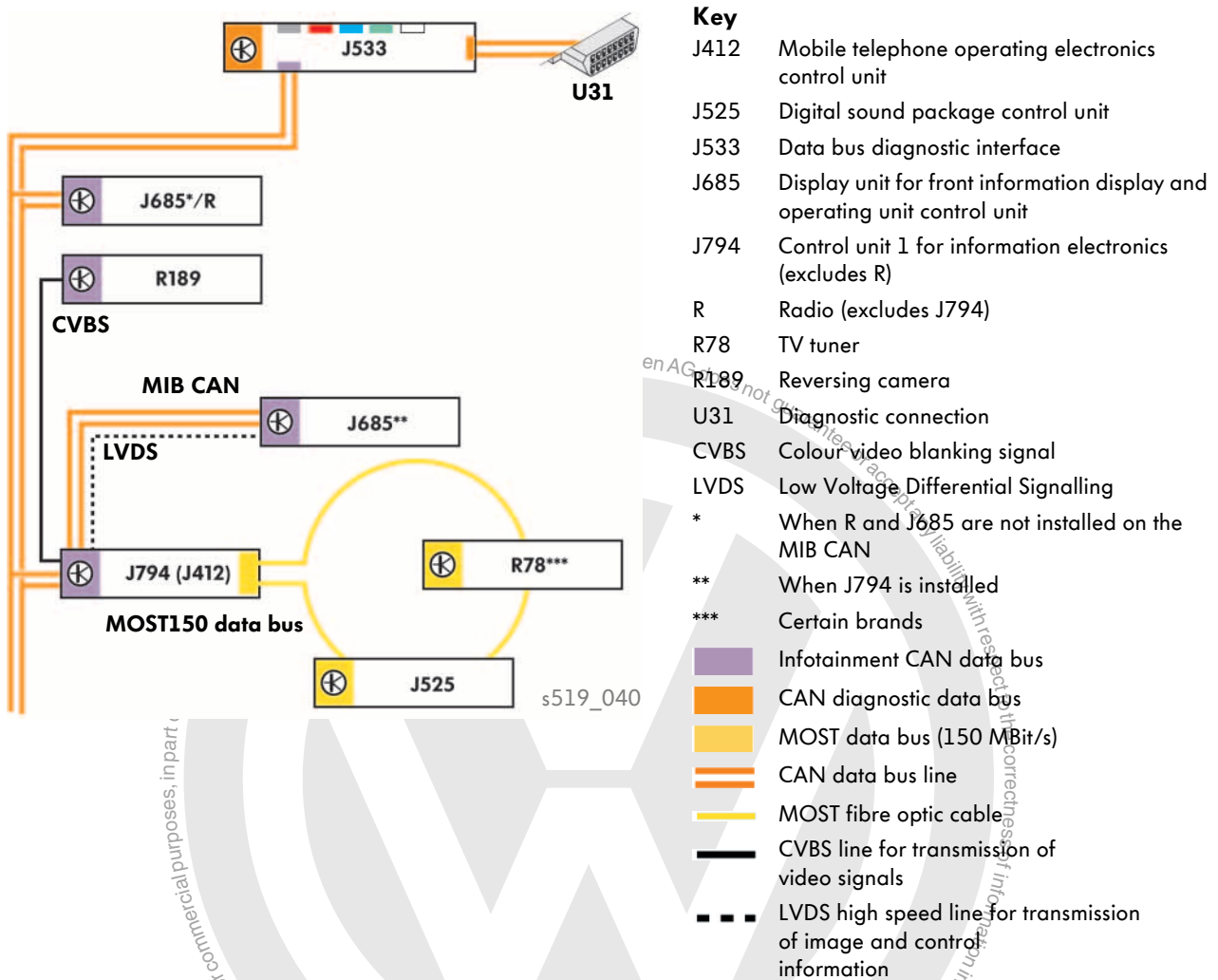

Further information about the ring circuit break diagnostic and the new fibre optic line repair set can be found in the "Service" chapter beginning on page 26.



Networking concept

The MOST data protocol



The data to be transmitted are divided into data packets, or so-called frames. Each frame in the MOST150 data bus is 3072 bits long (MOST25 = 512 bits). The useful digital data length is 3040 bits (MOST25 = 480 bits). This means that significantly more information is transmitted per data packet in the MOST150.

The overall length of a frame is composed of:

- A data field for administrative purposes
- A data field for control data
- Two data fields.

The maximum amount of data that can be saved in these two data fields is limited by this fixed division.

The data are transmitted via three channels (control, synchronous and asynchronous):

- Via the control channel for control data
- Via the synchronous channel for audio and video data transfer (synchronous real-time transfer without buffering)
- Via the asynchronous channel for greater amounts of data, e.g. metadata of audio files (asynchronous, event-driven data transfer, buffering possible)

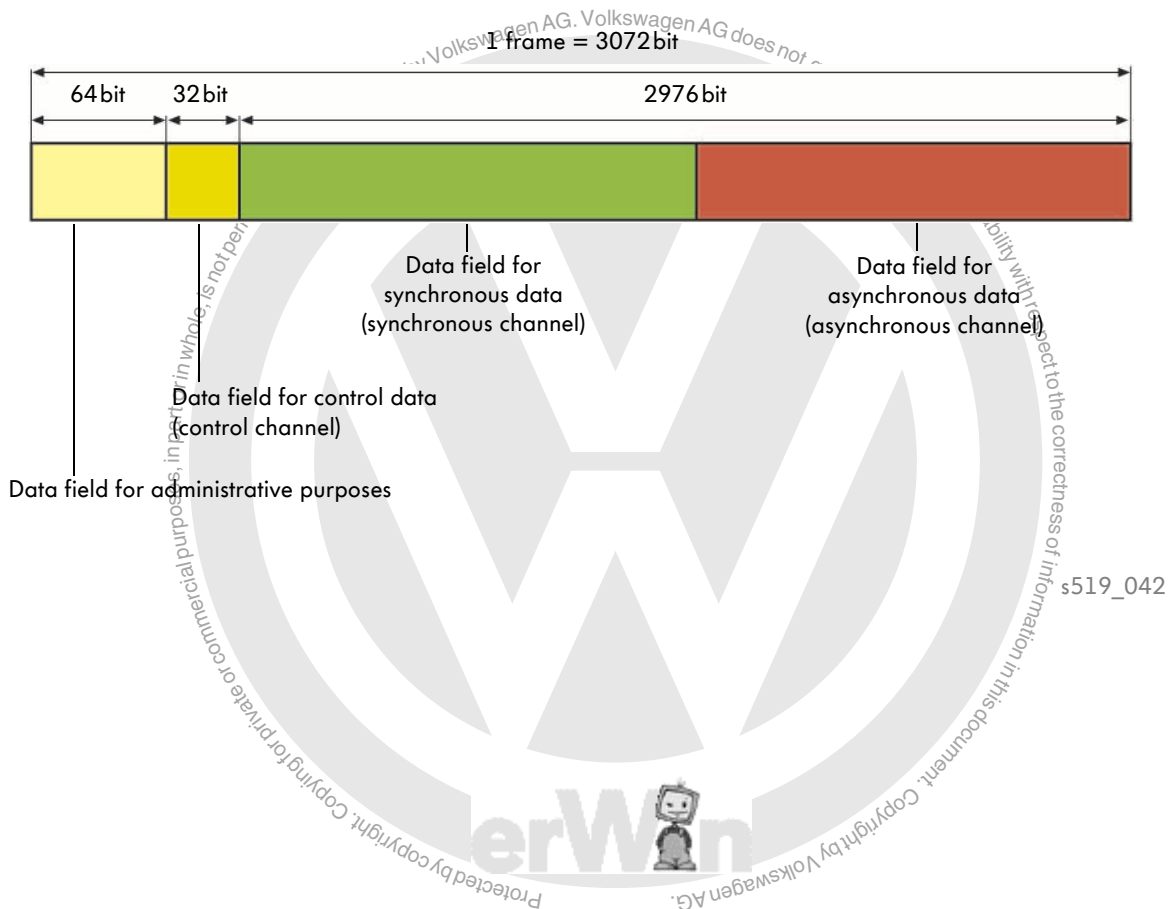

The structure of fibre optic cables

The fibre optic cable consists of several layers:

- The outer, coloured sheath is for identification, protection against mechanical damage, and temperature protection.
- The black, inner sheath protects the core against light irradiation from the outside.

Cladding (fluorinated polymer) is a layer around the core with a lower refractive index to light. It has a thickness of a few μm and ensures that the light conveyed along the edge of the core is reflected back to the centre of the core, thus preventing loss of light from the core at the "edges".

The core is the central part of the fibre optic cable. It is made of specially conditioned Plexiglas. It conveys the conducted light nearly loss-free.

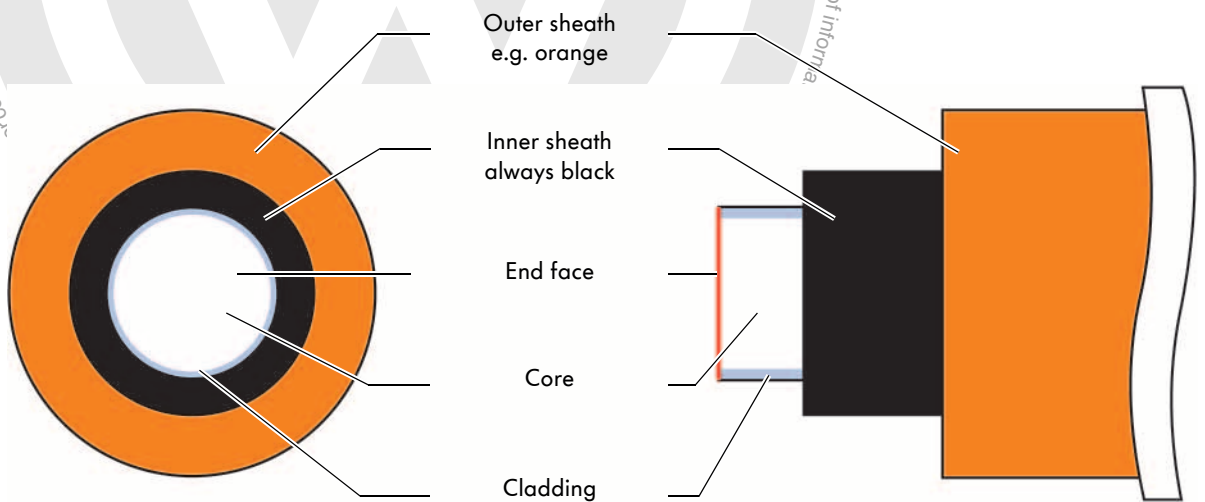

s519_043



To guarantee properly functioning data transmission, the facing surface of the fibre optic cable must be smooth, vertical and clean. Soiling and scratches on the facing surface may cause faults and losses during data transmission and negatively impact the performance of the fibre optic cable.



Networking concept

The aerial systems

There are two types of aerial systems:

- The aerial system for the “Comfort” mobile telephone interface with two-way signal amplifier for mobile telephone/data services J984 and storage compartment with interface for mobile telephone R265 (pairing box), and
- the aerial system for the “Premium” mobile telephone interface with direct connection of GSM aerial R205 to control unit 1 for information electronics J794.

Each of these systems represents the maximum equipment level for the European market. The aerial design can vary from country to country in the individual markets.

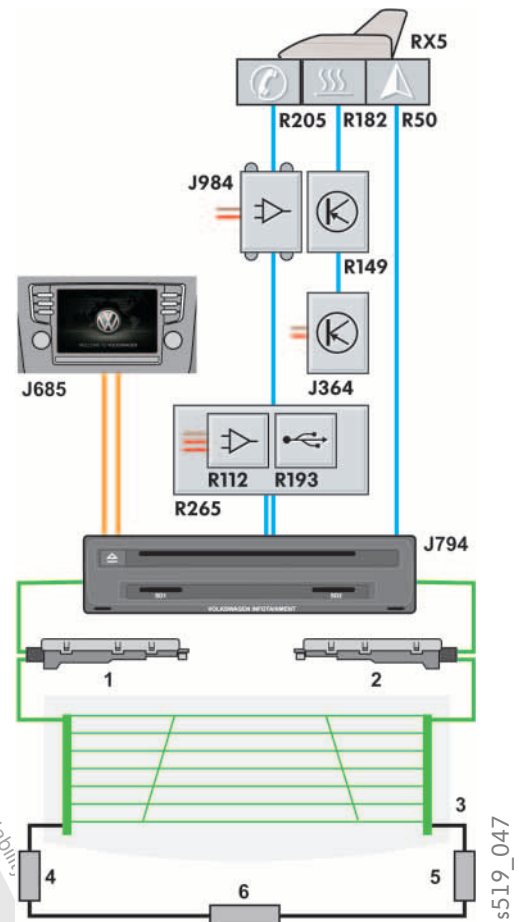

The aerial system of the “Comfort” mobile telephone interface

The FM/AM radio aerials are located in the rear window of the Golf 2013.

Auxiliary heater aerial R182, which is for the remote control of the auxiliary heater, GSM aerial R205 for the telephone connection, and GPS aerial R50 for vehicle location and navigation operation are located in roof aerial RX5.

Roof aerial RX5 and the impedance transformer are standardised components of the MQB.

The pairing box enables a non-rSAP-compatible phone to be connected to GSM aerial R205 of the vehicle via an induction connection without specific connectors or cable adapters.

Key

- J364 Auxiliary heater control unit
- J685 Display unit for front information display and operating unit control unit
- J794 Control unit 1 for information electronics
- J984 Two-way signal amplifier for mobile telephone/data services
- R50 GPS aerial
- R112 Aerial amplifier 3
- R149 Remote control receiver for auxiliary coolant heater
- R182 Auxiliary heater aerial
- R193 USB connection holder
- R205 GSM aerial
- R265 Storage compartment with interface for mobile telephone
- RX5 Roof aerial
- 1 Impedance transformer FM/DAB
- 2 Impedance transformer FM/AM
- 3 FM/AM aerial in the rear window
- 4, 5 FM blocking circuit
- 6 AM blocking circuit

- CAN data bus line
- Actuator wire
- Sensor line

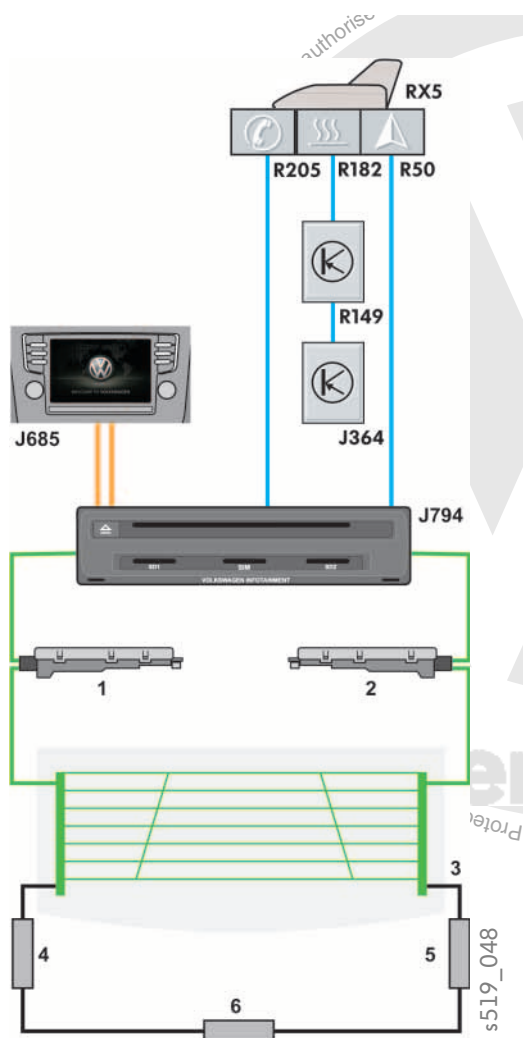

The aerial system of the “Premium” mobile telephone interface

If the optionally available “Premium” mobile telephone interface is installed, control unit 1 for information electronics J794 is equipped with a telephone module and a SIM card reader. This makes it possible to implement the functionality of a fixed installation phone using a mobile telephone when the SIM card is inserted. If the SIM card is not inserted, a mobile telephone can still be paired via the three Bluetooth profiles rSAP, HFP or A2DP to control unit 1 for information electronics J794. The telephone module installed in control unit 1 for information electronics J794 is designed for GSM and UMTS networks.

Also, a WLAN hotspot can be set up in the vehicle with the “Premium” mobile telephone interface. This makes it possible for WLAN compatible devices to use the Internet connection with the SIM card inserted or when an rSAP mobile telephone is paired.

Key

- J364 Auxiliary heater control unit
- J685 Display unit for front information display and operating unit control unit
- J794 Control unit 1 for information electronics
- R50 GPS aerial
- R149 Remote control receiver for auxiliary coolant heater
- R182 Auxiliary heater aerial
- R205 GSM aerial
- RX5 Roof aerial
- 1 Impedance transformer FM/DAB
- 2 Impedance transformer FM/AM
- 3 FM/AM aerial in the rear window
- 4, 5 FM blocking circuit
- 6 AM blocking circuit
- CAN data bus line
- Actuator wire
- Sensor line



Telephone preparations

Overview of the mobile telephone preparations

| Feature/function | Basic | Comfort | Premium |
|---|-------|---------|---------|
| Operation and display using the "Plus" or "Premium" multifunction indicator and TFT touchscreen of the radio, of the radio navigation system, or via an optional multifunction steering wheel | X | X | X |
| Hands-free system | X | X | X |
| The mobile telephone can be easily paired using Secure Simple Pairing (SSP) | X | X | X |
| Easy telephone book access using Phone Book Access Profile (PBAP) | X | X | X |
| Telephone contact with image representation ¹⁾ | X | X | X |
| Telephone contact address data can be used for entering destinations in the navigation system ²⁾ | X | X | X |
| Bluetooth audio wireless communication interface (exclusively compatible with Advanced Audio Distribution Profile A2DP) ¹⁾ | X | X | X |
| The audio data stored on the mobile telephone can be accessed using the TFT touchscreen (AVRCP 1.3) | X | X | X |
| Voice control | | X | X |
| Connection to the external aerial via the charge holder in the centre console (pairing box) | | X | |
| Vehicle's own GSM/UMTS transmission & reception unit with SIM card slot | | | X |
| Additional Bluetooth interface remote SIM Access Profile (rSAP) ³⁾ | | | X |
| WLAN hotspot | | | X |
| SMS functions: read ⁴⁾ , write (via speech input), read out loud | | | X |
| Suitable for mobile telephones with Bluetooth interface Hands Free Profile 1.5 (HFP 1.5) and GSM 900/1800MHz | X | X | X |

1) Not in conjunction with "Composition Touch" or "Composition Colour"

2) Not in conjunction with "Discover Media" or "Discover Pro"

3) It is necessary to check whether the mobile telephone has a Bluetooth interface with remote SIM Access Profile (rSAP) and is suitable for the "Premium" mobile telephone interface.

Further information is available at <http://www.volkswagen-zubehoer.de/>

4) Via the TFT touchscreen of the radio and radio navigation system

The “Comfort” mobile telephone interface

Design

The “Comfort” mobile telephone interface is characterised in the system design by two special features:

1. The storage compartment with interface for mobile telephone R265 (pairing box) in the centre console with aerial amplifier 3 R112
2. The two-way signal amplifier for mobile telephone/data services J984

Audio data for the hands-free device are transmitted directly via Bluetooth using the Hands Free Profile (HFP) to control unit 1 for information electronics J794 as are the data for the audio streaming via the A2DP protocol.

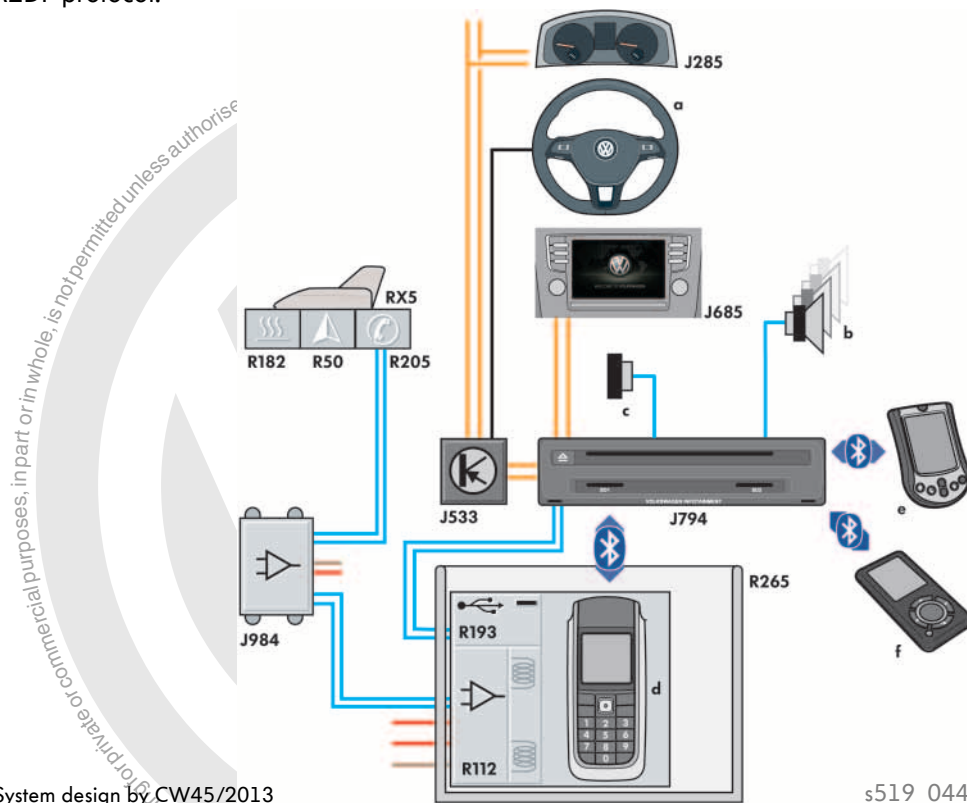

System design by CW45/2013

s519_044

Key

| | | | |
|------|--|------|---|
| J285 | Control unit in dash panel insert | R265 | Storage compartment with interface for mobile telephone |
| J533 | Data bus diagnostic interface | RX5 | Roof aerial |
| J685 | Display unit for front information display and operating unit control unit | a | Multifunction steering wheel (optional) |
| J794 | Control unit 1 for information electronics | b | Vehicle loudspeaker |
| J984 | Two-way signal amplifier for mobile telephone/ data services | c | Vehicle microphone |
| R50 | GPS aerial | d | Bluetooth mobile telephone |
| R112 | Aerial amplifier 3 | e | e.g. handheld |
| R182 | Auxiliary heater aerial | f | e.g. MP3 player |
| R193 | USB connection holder | | |
| R205 | GSM aerial | | |
| | | | CAN data bus line |
| | | | Actuator wire |
| | | | LIN data bus |

Telephone preparations

Storage compartment with interface for mobile telephone R265 (pairing box)

The storage compartment with interface for mobile telephone R265 (pairing box) includes the aerial amplifier 3 R112 and USB connection holder R193. Aerial amplifier 3 R112 has an adapter plate for the wireless aerial connection of the mobile telephone to the aerial system of the vehicle using the principle of induction. The connection is by means of two surface pairing aerials on the top and bottom side of the aerial amplifier. This makes reception in the entire space of the pairing box possible. A retaining strap on the adapter plate is there to secure the mobile telephone.

USB connection holder R193 serves as a charging interface up to and including construction week 45/2013. At the beginning of construction week 46/2013 it can also be used with USB charging socket 1 U37 for data transmission. This is made possible by USB hub R293. It connects USB charging socket 1 U37 in the pairing box and the connection for external audio sources R199 with control unit 1 for information electronics J794.

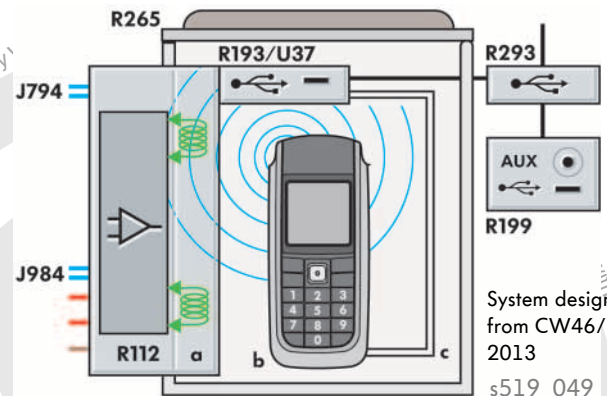

Key

- J794 Control unit 1 for information electronics
- J984 Two-way signal amplifier for mobile telephone/data services
- R112 Aerial amplifier 3
- R193 USB connection holder
- R199 Connection for external audio sources
- R293 USB hub
- R265 Storage compartment with interface for mobile telephone
- U37 USB charging socket 1
- a Adapter plate with 2 pairing aerials
- b Mobile telephone
- c Data/charging cable of the mobile phone

The two-way signal amplifier for mobile telephone/data services J984

The GSM and UMTS aerial of the mobile telephone is also connected via the pairing box to an HF amplifier to improve the transmission and reception conditions even more. The two-way signal amplifier for mobile telephone/data services J984 is mounted behind the right luggage compartment trim and electrically connected between pairing box and roof aerial RX5.

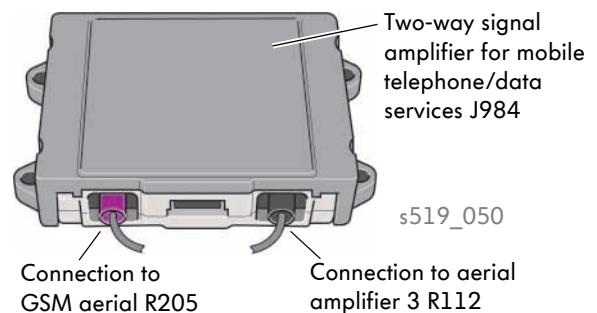

The “Premium” mobile telephone interface

When the vehicle is equipped with the “Discover Pro” infotainment system, the optional “Premium” mobile telephone interface is also available.

Design



The key features of the “Premium” mobile telephone interface include:

- An additional SIM card slot in control unit 1 for information electronics J794
- A special telephone module in control unit 1 for information electronics J794
- The possibility to activate and use a vehicle-internal WLAN hotspot.

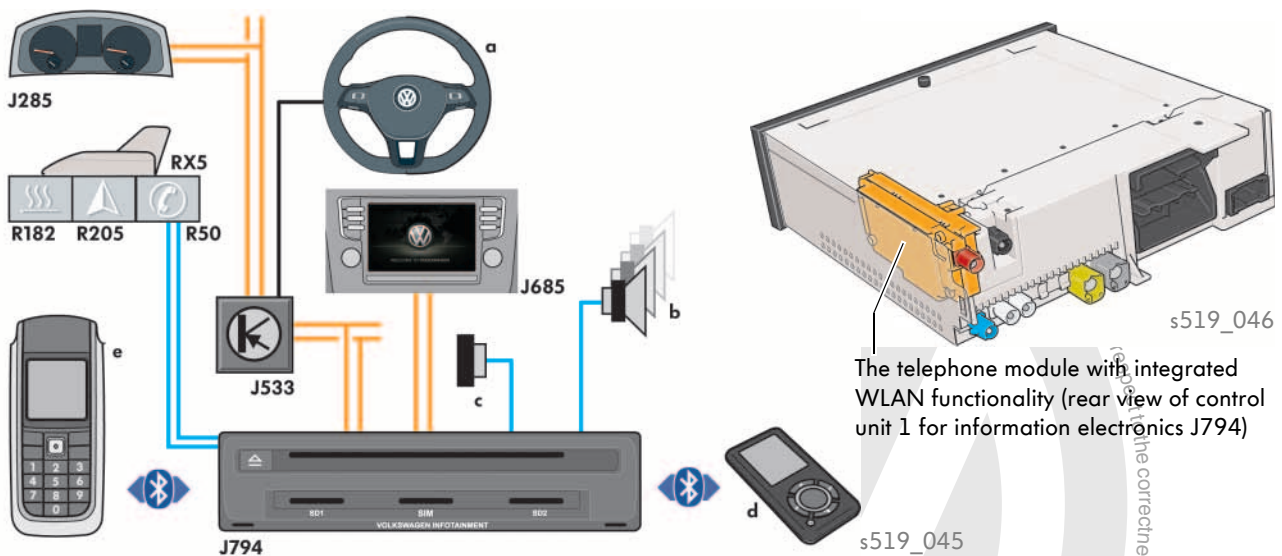
With the telephone module and the SIM card slot it is possible to provide the functionality of a fixed installation phone when the SIM card is inserted. An inserted SIM card has priority over the wireless Bluetooth pairing. If a SIM card is not inserted in the SIM card slot, a mobile telephone can still be paired via the Bluetooth profiles rSAP, HFP or A2DP to control unit 1 for information electronics J794. The telephone module in control unit 1 for information electronics J794 is designed for operation with GSM and UMTS networks.



Key

- | | | | |
|------|--|---|---|
| J285 | Control unit in dash panel insert | a | Multifunction steering wheel (optional) |
| J533 | Data bus diagnostic interface | b | Vehicle loudspeaker |
| J685 | Display unit for front information display and operating unit control unit | c | Vehicle microphone |
| J794 | Control unit 1 for information electronics | d | Other Bluetooth devices |
| R50 | GPS aerial | e | Bluetooth mobile telephone |
| R182 | Auxiliary heater aerial | | |
| R205 | GSM aerial | | |
| RX5 | Roof aerial | | |
-  CAN data bus line
 Actuator wire
 LIN data bus



Telephone preparations

WLAN integrated into the vehicle

WLAN stands for “Wireless Local Area Network” and uses a wireless, local radio network (hotspot) for data exchange. Wireless connection of multimedia devices or telephones only used to be possible via the Bluetooth interface in the Infotainment system. With the help of the new WLAN hotspot integrated into the vehicle, devices such as tablet PCs and laptops can now be connected to the Internet with the “Premium” mobile telephone interface. For this purpose the UMTS interface integrated into the telephone module is used.

Data transfer via GSM aerial R205 is either with a Bluetooth paired rSAP-compatible mobile telephone or an Internet-compatible SIM card inserted into the SIM card slot of control unit 1 for information electronics J794.

The UMTS 3G standard is used for transmission. It is a third generation UMTS standard that permits data transmission speeds of up to 42 Mbit/s. A maximum of 8 devices can be operated simultaneously on the hotspot. Use of the hotspot by unauthorised third parties is not possible because of the SSID (Service Set Identifier) and because hotspot coverage is limited outside of the vehicle. The SSID is the name of the WLAN hotspot; access to the network is enabled by entering a password. The “access point” is integrated into the telephone module and serves as the interface for wireless communication devices in the WLAN.

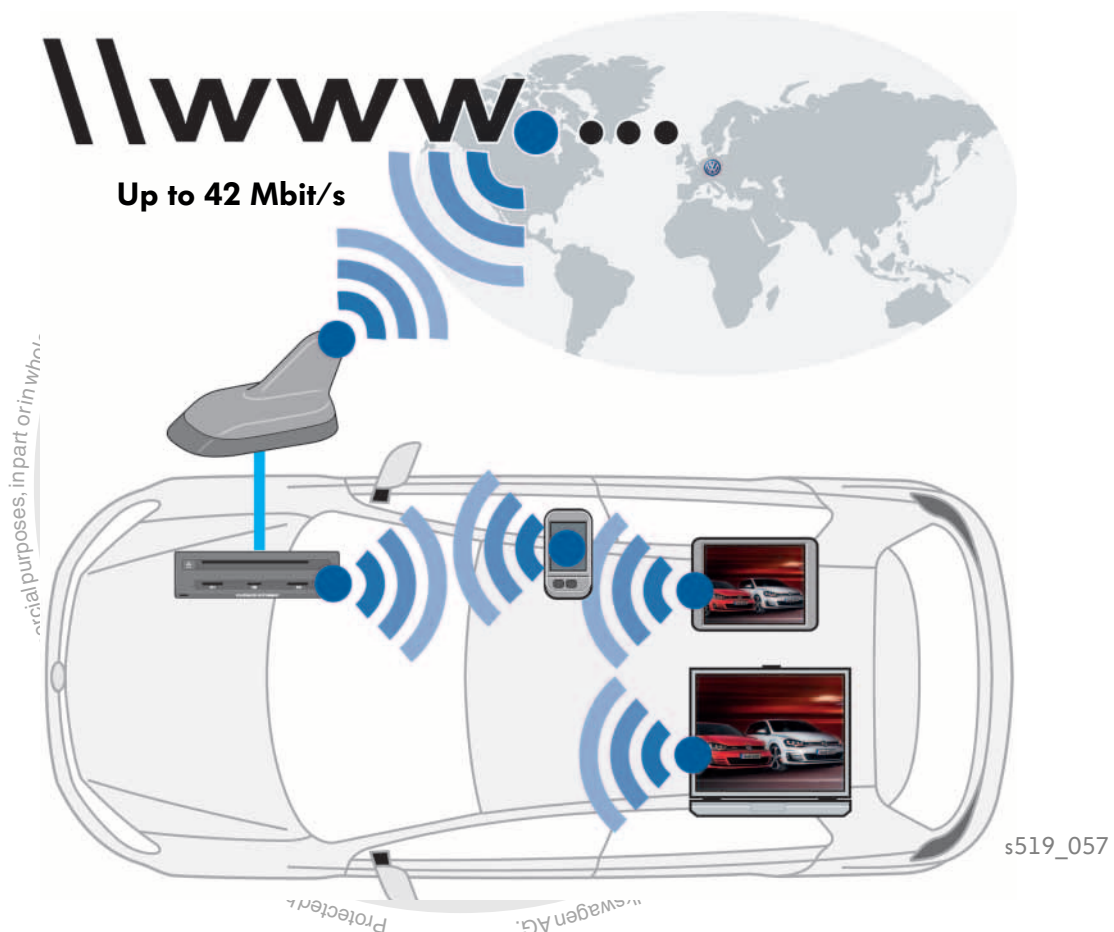

WLAN standards IEEE 802.11b and 802.11g



WLAN setup

WLAN

Security level: WPA2

Network key: PIPK*sSI

SSID: VW68675

Do not send network name (SSID)

Restore factory settings

Seven-digit SSID

s519_065

Service Set Identifier (SSID), or “network name”

SSID is the name for a radio network based on the IEEE 802.11.

The SSID character string may be a maximum of 32 characters. It is configured from the access point of a wireless network (WLAN) and set from all devices that are to have access to it. The character string is prefixed to all data packets unencrypted.

If a device requests access to a WLAN, all reachable access points transmit their SSIDs. The radio network you want to access can then be selected from a list.

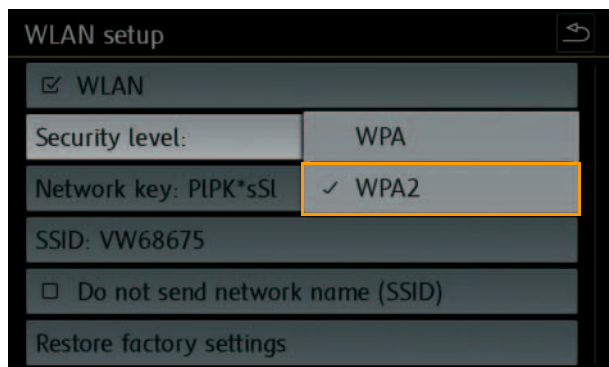

WLAN setup

WLAN

Security level: WPA

Network key: PIPK*sSI WPA2

SSID: VW68675

Do not send network name (SSID)

Restore factory settings

s519_066

WPA and WPA2 encryption

The abbreviation WPA stands for “Wi-Fi Protected Access” and refers to a method of encrypting wireless networks.

WPA2 is considered more secure than WPA provided the password defined by the central computer is used. The user can nevertheless still use the conventional WPA method.

What does IEEE 802.11 mean?

IEEE 802.11 is an IEEE standard (Institute of Electrical and Electronics Engineers) for communication within radio networks. The standard is continuously being further developed and indexes incremented upwards. The 802.11 standards family currently includes 12 standards that are primarily related to bandwidth, radio frequency, and transmission speed. Standards 802.11b and 802.11g are currently used in the modular infotainment matrix, i.e. it is possible to communicate with all devices that have one of these two standards.

The data transfer rate of the 802.11b standard is 11Mbit/s with a frequency band of 2.4GHz.

The data transfer rate of the 802.11g standard is 54Mbit/s with a frequency band of 2.4GHz.



Driving profiles

The driving profile selection in the Golf 2013

The “Comfort”, “Normal”, “Sport”, “Eco” and “Individual” driving profiles are available for the Golf 2013, Golf Estate 2013 and Golf GTI/GTD 2013, provided they have the optionally available driving profile selection. Since the modular transverse matrix (MQB) has been used in the Golf GTI/GTD 2013, additional functions and participants have been added to the driving profile selection. This includes the interior and exterior sound control as well as the regulation of the front differential lock, which is explained in this chapter.

| Function/participant | Golf/ Estate | Golf GTI | Golf GTD |
|---|-----------------|-------------|-------------|
| Engine management system | X | X | X |
| Start/stop function | X | X | X |
| Gearbox management system | X | X | X |
| Steering control (EPS) | X | X | X |
| Damper control (DCC) | X | X | X |
| Climate control | X | X | X |
| Distance control (ACC) | X | X | X |
| Interior sound control (SAK) | -- | X | X |
| Dynamic cornering light (AFS) | X | X | X |
| Reversible belt tensioner (RGS) | X | X | X |
| Gearbox freewheel* (“freewheel”) | X | X | X |
| Exterior sound control in the exhaust system | -- | -- | X |
| Control front differential lock (VAQ) | -- | X | X |

* Only with dual clutch gearbox (DSG)

The driving profiles in Golf GTI/GTD 2013

Besides the vehicle-specific design of the individual profiles, the driving profiles in the Golf GTI/GTD 2013 are primarily characterised by three features:

- Front differential lock (VAQ)
- Actuator for structure-borne sound R214
- Actuator 1 for engine sound generator R257 (optional and only for GTD).



The front differential lock (VAQ)

The Golf GTI “Performance” adds the front differential lock to the running gear. The axle differential lock control unit J647 electronically distributes the drive torque to match the driving situation and actively counteracts understeering when cornering. The control behaviour of the front differential lock is influenced by the driving profile “Normal” or “Sport”.

Actuator for structure-borne sound R214

A new control unit for structure-borne sound J869 is featured in the Golf GTI/GTD 2013. It actuates the actuator for structure-borne sound R214 that stimulates the windscreen due to vibrations and thereby creates an artificial engine noise in the passenger compartment. The actuation control also takes into account the selected driving profile besides the speed-sensitive output of the created vibrations.

Actuator 1 for engine sound generator R257

The active exhaust system was specially developed for the Golf GTD 2013 and is a component of the optionally available Sport and Sound packages. The engine sound generator control unit J943 is connected to the powertrain CAN bus. Depending on the speed and driving mode, the sound system integrated into the exhaust system generates a sportier engine sound.

Sound system

The high-end sound system “DYNAUDIO Excite”

The “DYNAUDIO Excite” sound package can be optionally added to the infotainment system. In this sound package, 8 loudspeakers and a dual coil bass loudspeaker (subwoofer) are supplied with power from a 10-channel amplifier.

This new DYNAUDIO sound system has a subwoofer fitted for the first time in the spare wheel well. The two-way system in the front and rear seat areas, each consisting of a tweeter and a mid-bass driver, produces a dynamic, well-balanced sound. The finely tuned subwoofer compliments the sound reproduction with a powerful bass.

The positions of the sound components in the vehicle

Loudspeaker in right A-pillar



Loudspeaker in front right door

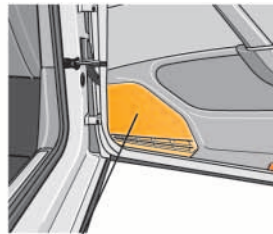

Loudspeaker in rear right door

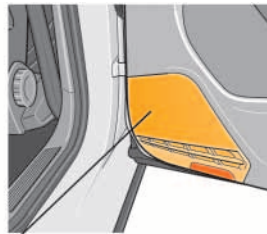

Digital sound package control unit J525

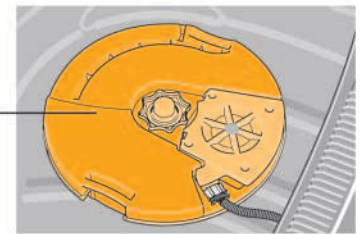
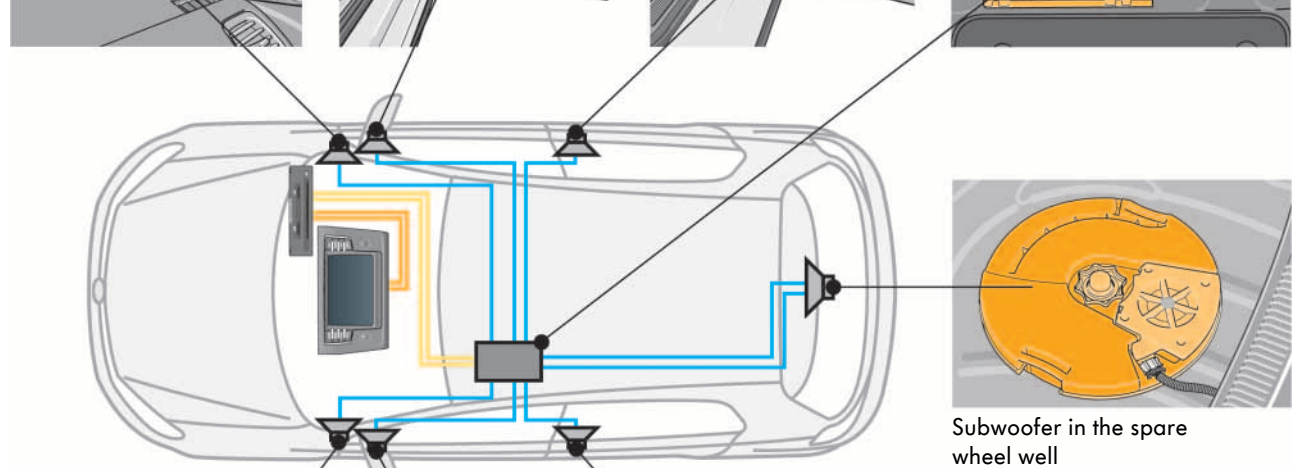
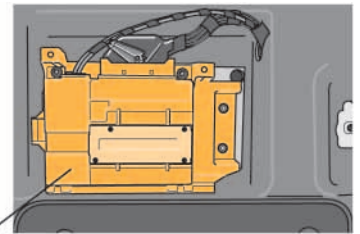

Subwoofer in the spare wheel well



Loudspeaker in left A-pillar

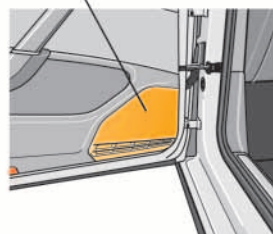

Loudspeaker in front left door

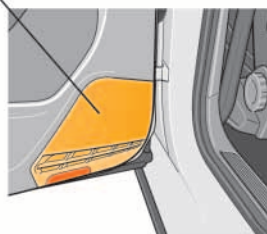

Loudspeaker in rear left door

Key

- Loudspeaker line
- CAN data bus line
- MOST fibre optic cable

s519_063

System overview

The high-end sound system DYNAUDIO consists of a 10-channel, 400-Watt MOST amplifier, 8 loudspeakers and a 10.5 litre dual-coil subwoofer in the spare wheel well. The sound system “DYNAUDIO Excite” is also optionally available for infotainment systems “Composition Media”, “Discover Media” and “Discover Pro” for every Golf 2013.

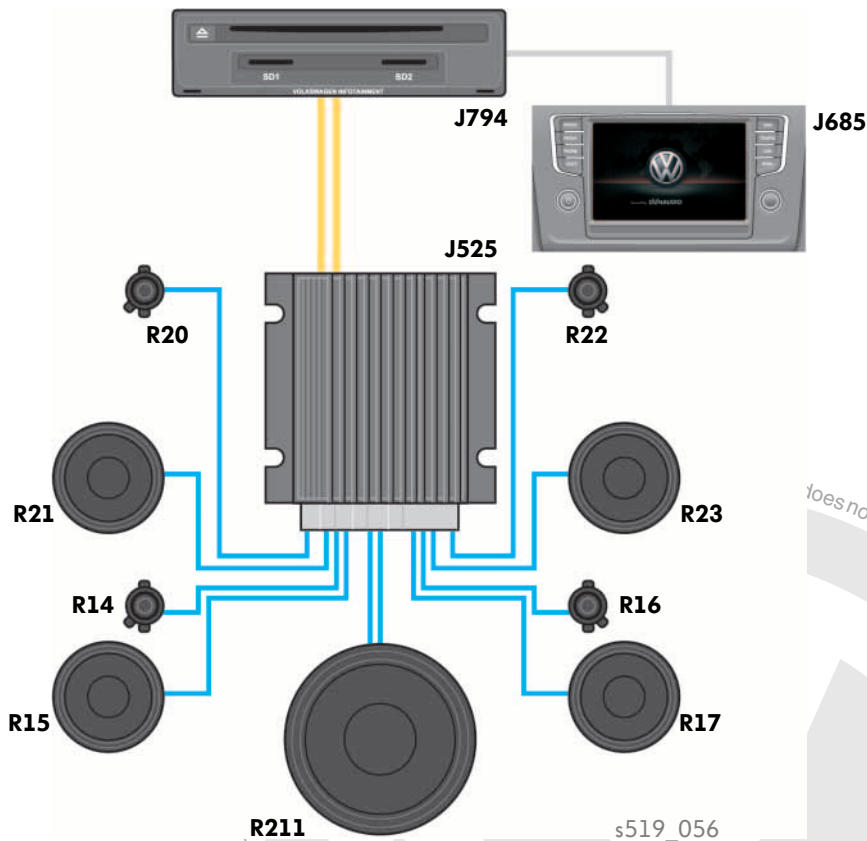

Key

- R14 Rear left treble loudspeaker
- R15 Rear left bass loudspeaker
- R16 Rear right treble loudspeaker
- R17 Rear right bass loudspeaker
- R20 Front left treble loudspeaker
- R21 Front left bass loudspeaker
- R22 Front right treble loudspeaker
- R23 Front right bass loudspeaker
- R211 Subwoofer
- J525 Digital sound package control unit
- J685 Display unit for front information display and operating unit control unit
- J794 Control unit 1 for information electronics
- MOST fibre optic cable
- Loudspeaker output line



does not guarantee or accept any liability with respect to the correctness of information in this document. Copyright by Volkswagen AG.

Sound system

Electrical components

Digital sound package control unit J525

With the DYNAUDIO sound package the system's own amplifier is fitted under the front left seat and integrated into the MOST data bus system. The installation location can be seen on page 20 in the schematic diagram.

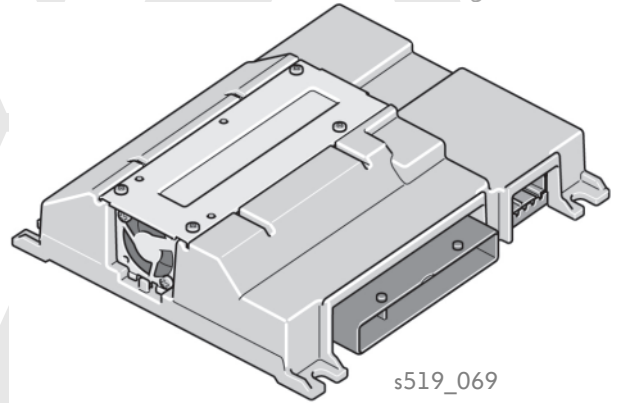

s519_069

The dual-coil subwoofer in the spare wheel well

New for the DYNAUDIO sound system is the fitted dual-coil subwoofer. The finely tuned subwoofer with dual voice coil, which is actuated via 2 output stages, compliments the sound performance with a powerful bass.

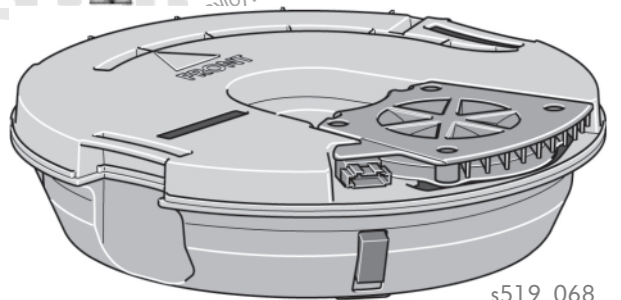

s519_068

The DYNAUDIO loudspeakers

The loudspeakers use membranes made of a magnesium-silicate-polymer material (MSP). The extremely lightweight aluminium voice coils are driven by internal magnets. This elaborate construction allows power and precision to be achieved with low weight and in the most compact of spaces, producing a highly dynamic, impressive bass and an absolutely clean, undistorted mid range.

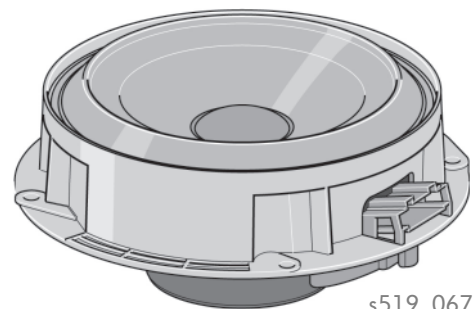

s519_067

Sound characteristics

A highlight of the DYNAUDIO sound system is the “Sound settings”. The sound reproduction can be varied to fit the listener's preferences. Thanks to the digital signal processing, this innovation from DYNAUDIO was also included in the Golf 2013 sound system. Five special sound settings that define different sound characteristics are available to the Golf driver:

- Authentic
- Soft
- Dynamic
- Speech
- Individual



s519_029

Authentic

This setting faithfully reproduces the music as authentically as possible to the original recording.

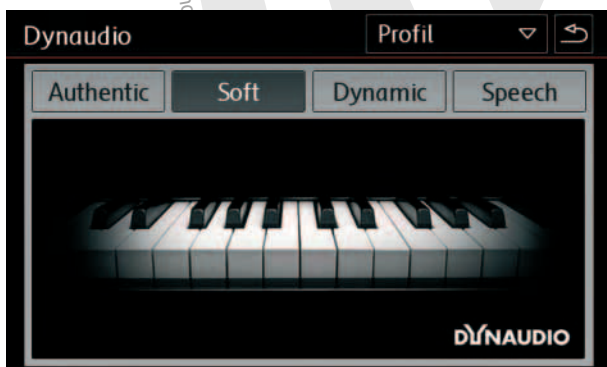

s519_030

Soft

This sound characteristic moderates the bass and treble.



s519_031

Dynamic

This sound setting is characterised by a strong bass and moderate treble.



Sound system

Speech

This setting emphasises the mid range for speech output.



s519_032

Individual

Individual settings of the low, mid and high ranges as well as the basic intensity of the subwoofer are possible with the slider.

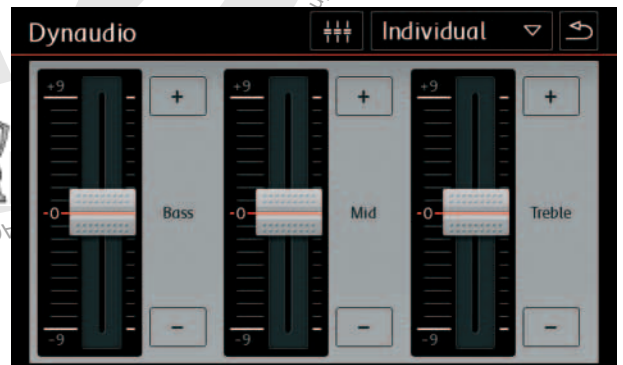

s519_033

Using the "Sound setup" menu, the user can access the setting options for sound characteristics, spatial options, and subwoofer settings.

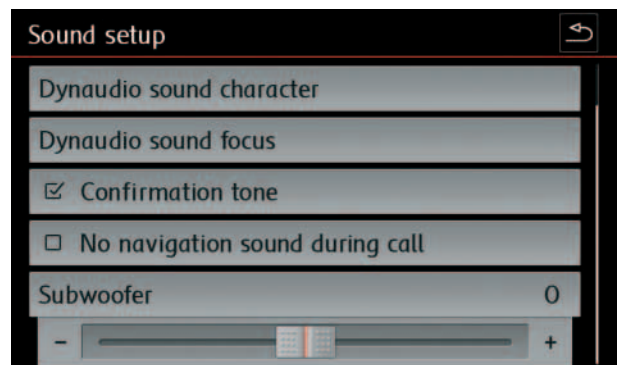

s519_034

Spatial sound reproduction

Sound reproduction based on seat positions

The digital sound package control unit J525 gives the user the option of adjusting the sound spatially. This involves much more than simply the balance and fader, and more than the sound output volume of the individual speakers is modulated. By means of a time delay of the relevant channels and additional frequency adjustments, the sound is dynamically adjusted so that the centre point of the sound is specifically oriented to individual seats. Alternatively, the centre point of the sound can be individually defined with the "Individual" sound characteristic. The primary adaptation is based on the specific interior shape and size of the space of a vehicle model.

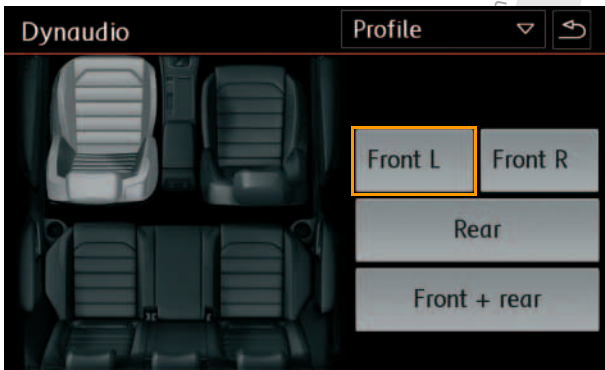

s519_036

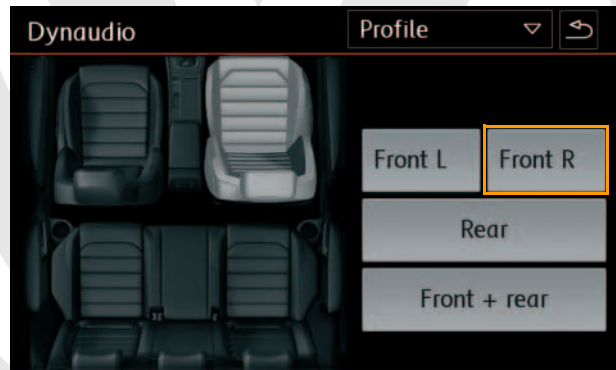

s519_036

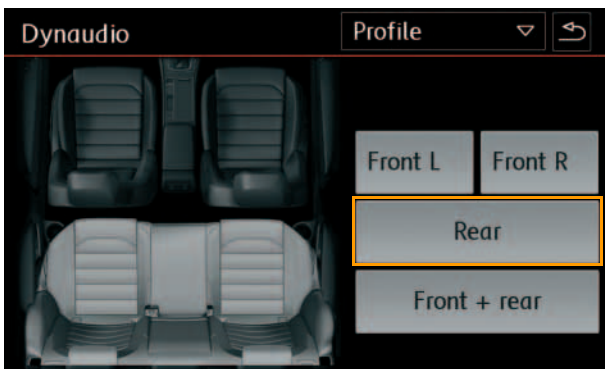

s519_037

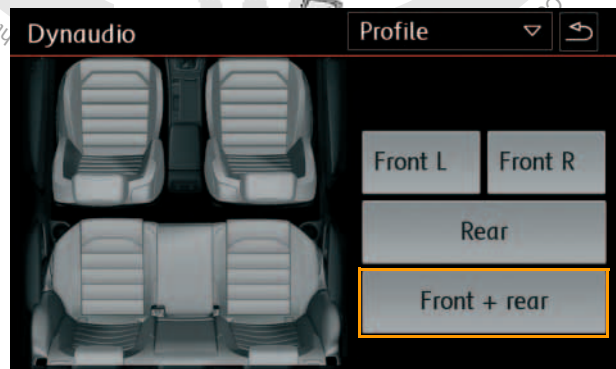

s519_038

Individual setting

Individual setting of the fader is possible using the cross-hairs and arrow keys.

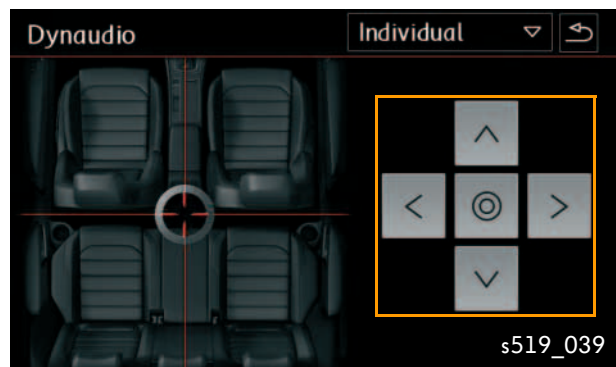

s519_039



Diagnostics and working on the MOST150 data bus

The procedure for ring circuit break diagnostics is primarily the same as for the check plan for the Touareg 2011. One difference with the Golf 2013 is that, due to the faster transmission and reception units, it is necessary to use a modified tool: the optical replacement control unit VAS 6778.

Ring circuit break diagnostic with the optical replacement control unit VAS 6778

With the optical replacement control unit VAS 6778 it is possible to check and troubleshoot fibre optic cables (localisation of defective control units or defective sections in the fibre optic cable).

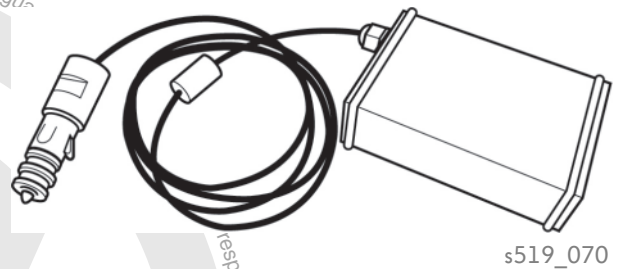

The fibre-optic conductor repair set VAS 6223B

The fibre-optic conductor repair set VAS 6223B is for repairing fibre optic cables that are already in use in the infotainment system.

Because new fibre optic cable must be laid next to the vehicle cable set when repaired, it has a different length than the original cable set. The defined bending radii of the fibre optic cable must be ensured to guarantee proper functioning.

For this reason special length adjustment is necessary.



Cutting pliers VAS 6228

This tool is designed for cleanly cutting cables with plastic or rubber sheathing.

It has so far been used with the Touareg for repair group 43 "Chassis" when working on the air suspension.

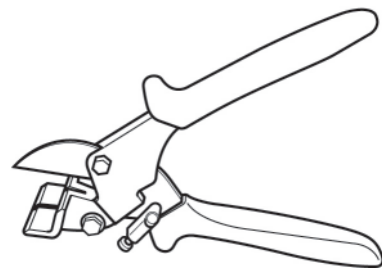

Updating navigation data

Procedure

An SD card with at least 32 GB storage capacity is needed for updating the navigation data for “Discover Pro”, and an SD-CDA card with at least 8 GB is needed for “Discover Media”.

Volkswagen recommends the use of a Class 10 card / SDHC card for “Discover Pro” and a special SD-CDA card with 8 GB for “Discover Media”, which can be purchased from a Volkswagen dealership.

For “Discover Pro” more than 17 GB storage capacity may be needed and for “Discover Media” more than 4 GB. Depending on the country or importer, various Internet addresses are available for downloading the navigation data: **www.volkswagen.de** for the German market and **www.navigation.com** for worldwide markets. These websites provide detailed information about downloading and installation in the language of the respective countries.

When installing the navigation data, it is important to follow the operating instructions for the respective vehicle. During the copying process the ignition must remain switched on and the navigation function is unavailable. Due to the large amount of data and depending on the SD card used, the process may take up to 4 hours. For this reason, make sure there is sufficient battery voltage to perform the update. If necessary, a suitable charging device must be connected to the vehicle.



Glossary

AVRCP

(Audio Video Remote Control Profile)
Bluetooth profile for remote control of audio and video devices.

A2DP

(Advanced Audio Distribution Profile)
A technology used by many manufacturers which allows wireless transmission of stereo audio signals to a corresponding receiver via Bluetooth.

Bandwidth

The bandwidth is a defined frequency range and is used, for example, for transmitting radio signals. In a wider sense, the term has now come to refer to the speed or quantity of data transmissions.

Data transmission rate (bit rate)

The data transmission rate is a measure of the speed of data transmission. It refers to the quantity of data that can be transmitted through a data channel (wire, radio channel, network) in a defined period of time. The data transmission unit of measure is bit/s.
 $1\text{Mbit/s} = 1,000\text{kbit/s} = 1,000,000\text{bit/s}$

Firewall

A firewall is a security system for preventing unauthorised external access to a computer's software. A firewall can be designed as a system component of a single computer or as a standalone computer whose sole function is to monitor access to a non-public network.

FOT

(Fibre Optical Transmitter)
Transmission and reception units designed for digital data transfer using fibre optic lines.

GPS

(Global Positioning System)
Officially NAVSTAR GPS, this is a global satellite navigation system for position location and time measurement.

GSM

(Global System for Mobile communications)
Standard for digital mobile telecommunications networks that is also used for data transfer and text messages (SMS).

Handheld

"Pocket-sized" portable computer used for keeping calendars, address lists and notes. It is also known as a personal digital assistant (PDA).

HFP

(Hands Free Profile)
Standard Bluetooth profile that enables communication between a mobile phone and a vehicle's hands-free system.

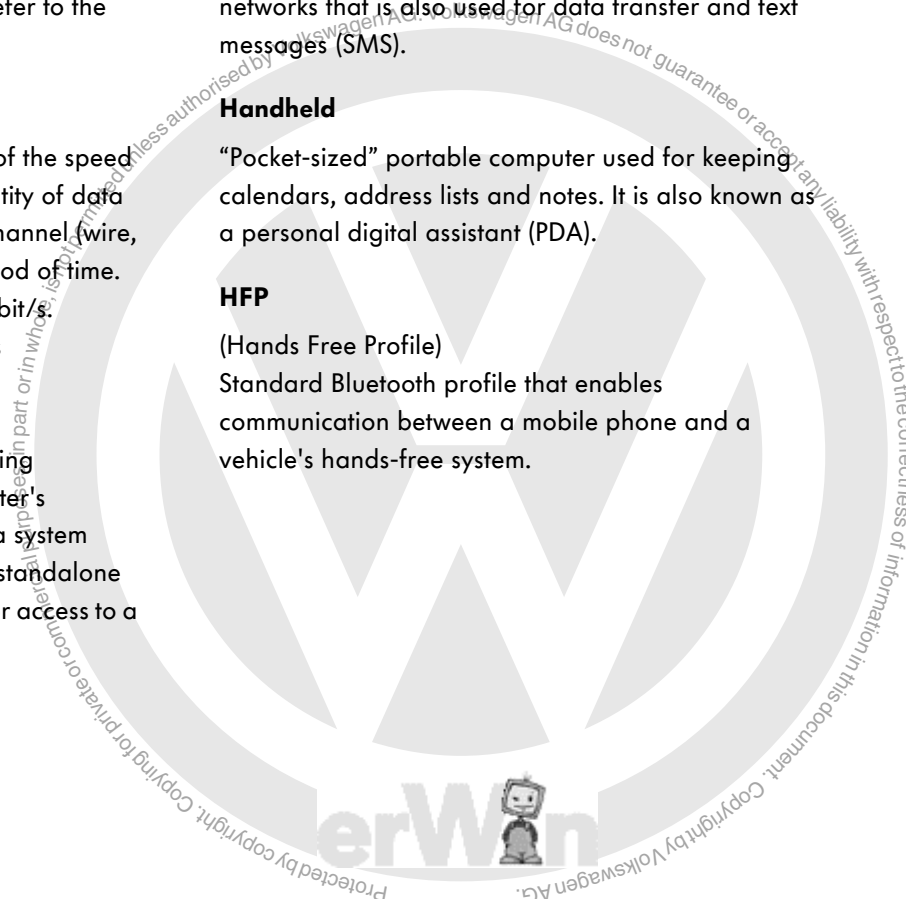

Hotspot

The term “hotspot” is often used to designate a public, wireless access point to the Internet.

MOST

(Media Oriented Systems Transport)

This is a serial bus system for transmitting audio, video, speech and data signals. Volkswagen currently uses fibre optic cable for this bus system.

rSAP

(remote SIM Access Profile)

Profile that enables reading the SIM card and using the access data by the universal mobile telephone preparation (UHV).

SD card

(Secure Digital card)

Small and robust memory card (e.g. for digital cameras).

SIM card

(Subscriber Identity Module card)

A SIM card is a chip card with a built-in processor that can be inserted into a mobile telephone. It can be used by a mobile telephone user to log into a telecommunication network.

SSID

(Service Set Identifier)

Identification number that allows a user to log into a wireless network. The SSID may be up to 32 characters long.

Subwoofer

(Bass loudspeaker)

Subwoofers are special speakers for producing very low frequency bass sounds. A distinction is made between active and passive subwoofers. Active subwoofers have their own amplifiers; passive subwoofers do not have their own amplifiers and are connected like a normal loudspeaker to an amplifier output.

UMTS (3G)

(Universal Mobile Telecommunications System)

A third generation mobile radio standard enabling significantly higher transfer rates.

USB

(Universal Serial Bus)

A standardised interface between various electronic devices such as computers, printers, scanners and televisions etc.

WPA, WPA2

(Wi-Fi Protected Access)

Encryption methods for logging on and transmitting data in wireless networks.

WPA2 is an advanced development of WPA and is considered very secure encryption.



Test your knowledge

Which answers are correct?

One or several of the given answers may be correct.

1. To carry out the Discover Pro update ...

- a) a Class 10 SD card with at least 32 GB of storage capacity must be used.
- b) a “VW”-branded Class 10 SD card with at least 32 GB of storage capacity must be used.
- c) a conventional SD card with at least 16 GB of storage capacity must be used.

2. Which mobile telephone interface on the Golf 2013 has a function enabling it to generate a WLAN hotspot?

- a) The “Comfort” mobile telephone interface.
- b) The “Premium” mobile telephone interface.
- c) The “Basic” mobile telephone interface.

3. Which special components are required for the “Comfort” mobile telephone interface function?

- a) Control unit 1 for information electronics J794 from “Composition Media” or “Discover Media” or “Discover Pro”, storage compartment with interface for mobile telephone R265 (pairing box) with aerial amplifier 3 R112, 2-way signal amplifier for telephony J984 and GSM aerial R205.
- b) Control unit for information electronics 1 J794 from “Composition Media” or “Discover Media”, storage compartment with interface for mobile telephone R265 (pairing box) with aerial amplifier 3 R112, and GSM aerial R205.
- c) Control unit 1 for information electronics J794 from “Composition Media”, the storage compartment with interface for mobile telephone R265 (pairing box) with aerial amplifier 3 R112, and GSM aerial R205.

4. How is the aerial amplifier 3 R112 connected to control unit 1 for information electronics J794 under the centre console?

- a) Via the CAN infotainment data bus and via Bluetooth if a mobile telephone is paired.
- b) Via Bluetooth if a mobile telephone is paired.
- c) Via two discrete control lines.



Solution:
1. a); 2. b); 3. a); 4. c)



© VOLKSWAGEN AG, Wolfsburg
All rights and rights to make technical alterations reserved.
000.2812.76.20 Technical status 09/2013

Volkswagen AG
After Sales Qualification
Service Training VSQ/2
Brieffach 1995
D-38436 Wolfsburg

♻️ This paper was manufactured from pulp that was bleached without the use of chlorine.