

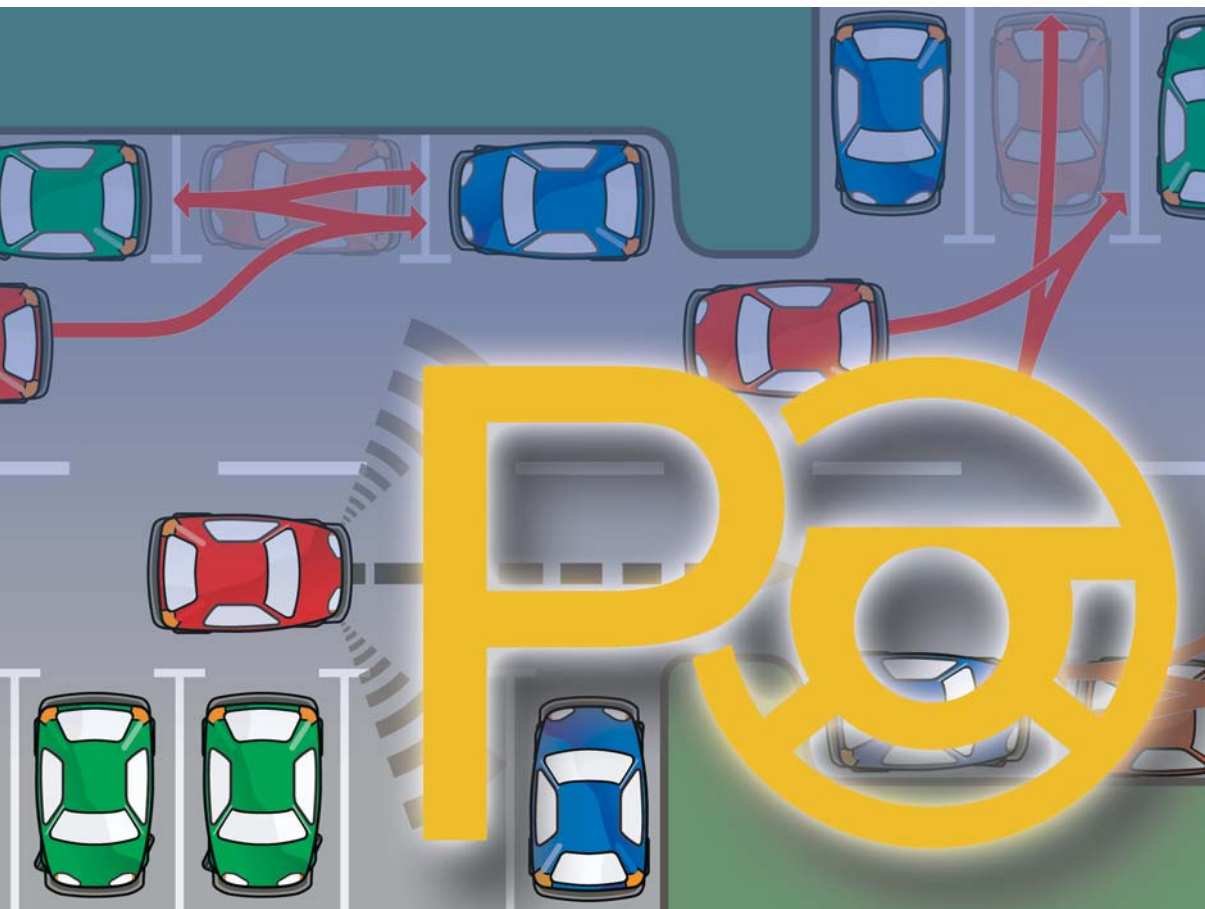

Self-study programme 494

Park assist steering 2.0

Design and function



The new park assist steering 2.0 is used in the 2nd generation Touran initially, followed by the Sharan 2011. It represents a considerable improvement over the already well established 1st generation park assist steering version 1.0, as well as the further developed 1.5 version.

With this new semi-automatic parking system, parking in bays perpendicular to the road and parking in even tighter parking spaces parallel to the road (kerb-side parking) have been made possible. In both instances, parking can be carried out in several stages.

As the first parking system of its kind, the 2nd generation park assist steering system features active brake intervention to reduce any potential damage from parking. The system still supports exiting from parallel parking spaces as before.

This self-study programme presents the main new features of the new park assist steering system compared with the earlier generation. The content covers the system components and the mode of operation.

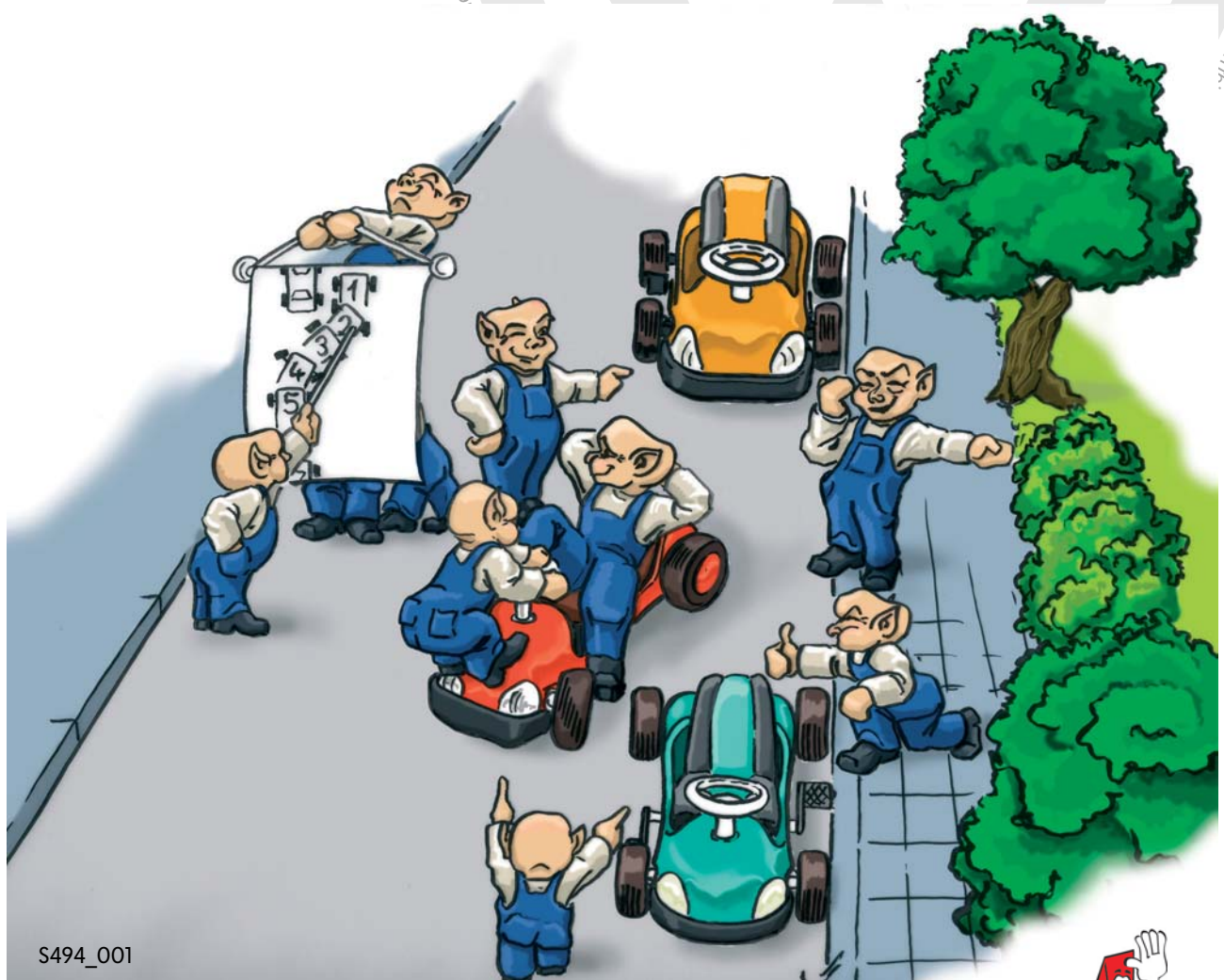

S494_001

The self-study programme portrays the design and function of new developments. The contents will not be updated.

For current testing, adjustment and repair instructions, refer to the relevant service literature.



**Caution
Note**



Introduction	4
System design	6
Mode of operation	8
Electrical components	24
Service	28
Test your knowledge	30



Introduction

Overview

The park assist steering system was first introduced with the Touran 2007. Park assist steering supports the driver when parking. It turns the steering wheel automatically. All the driver has to do is press the accelerator, engage the relevant gear and press the brake. The driver has the power to override the system at any time and end the park assist steering function.

With the park assist steering version 2.0, initially first used in the Touran and Sharan 2011, it is now possible to park in tighter parallel spaces. As well as the new perpendicular parking function, the system also offers new functions for parallel parking, such as full or partial parking on kerb stones, parking between other obstacles (trees, bushes or motorbikes) and also parking on bends. The system still supports exiting from parallel parking spaces.

The park assist steering functions comprise

- the parking aid, also referred to as park distance control PDC.
Also available without park assist steering, but has to be separately activated in a vehicle with park assist steering (e.g. when parking forwards).
- the steering function for the active parking process.

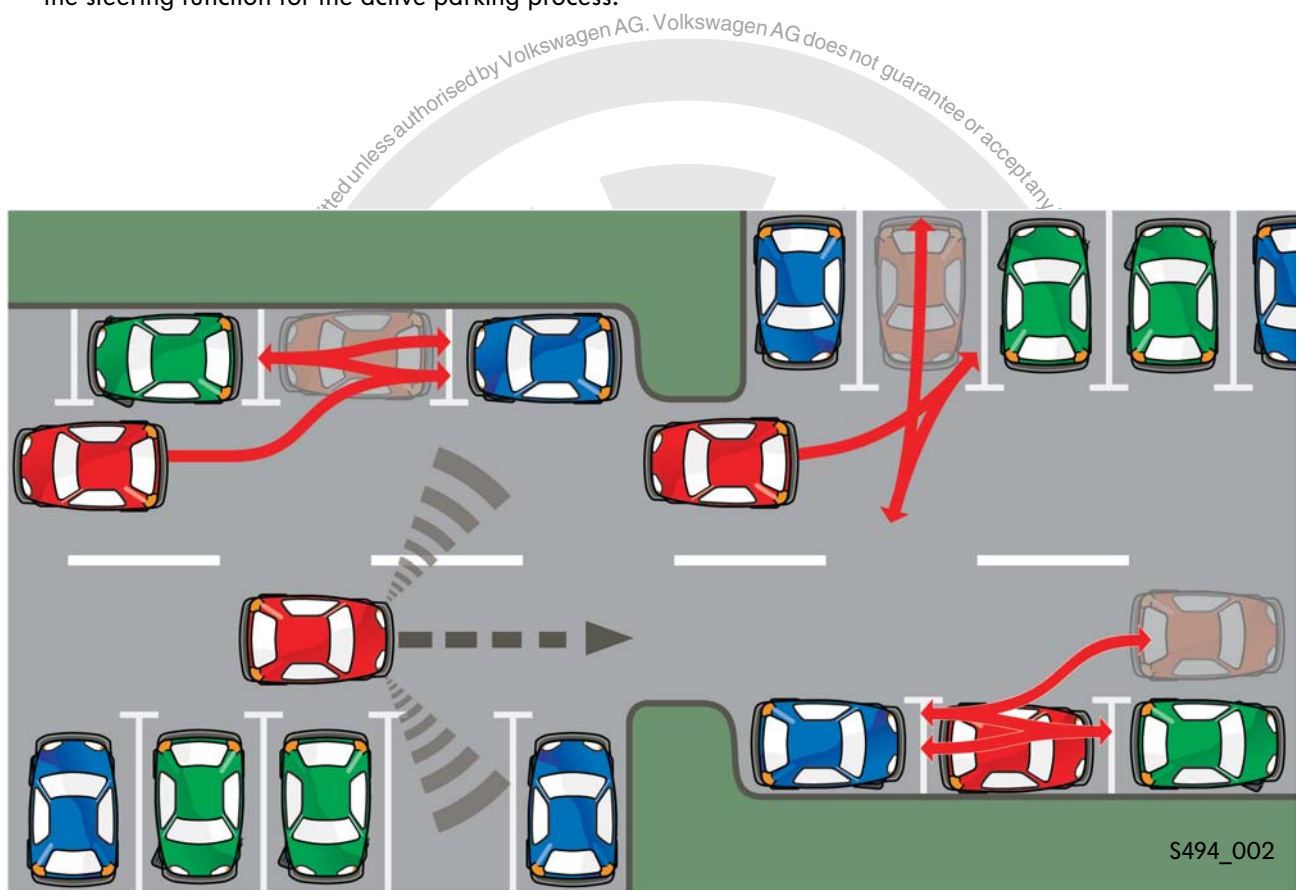

The level of luxury offered by park assist steering version 2.0 must not mislead the driver into a hazardous situation. The system cannot substitute the driver's concentration.

The driver must maintain control and an overview of the parking process and must not solely rely on the park assist steering.

System comparison

The use of 6 sensors at the front and rear respectively, an enhanced system network and further developed software facilitate the functions of park assist steering version 2.0.

		Park assist steering 1.0 1st generation	Park assist steering 1.5	Park assist steering 2.0 2nd generation
Sensors		<ul style="list-style-type: none"> - 6 senders at front, - 4 senders at rear 	<ul style="list-style-type: none"> - 6 senders at front, - 4 senders at rear 	<ul style="list-style-type: none"> - 6 senders at front, - 6 senders at rear
Parking space measurement		<ul style="list-style-type: none"> - permanent, even if park assist steering is inactive 	<ul style="list-style-type: none"> - permanent, even if park assist steering is inactive 	<ul style="list-style-type: none"> - permanent, even if park assist steering is inactive
Parking	Parallel parking	<ul style="list-style-type: none"> - Parking in parallel spaces - Parking against kerb stones - Length of parking space: Length of vehicle + 1.4m - Parking procedure Single stage - Maximum speed when searching for parking space: 30km/h 	<ul style="list-style-type: none"> - Parking in parallel spaces - Parking against kerb stones - Length of parking space: Length of vehicle + 1.1m - Parking procedure Single or several stages - Maximum speed when searching for parking space: 30km/h 	<ul style="list-style-type: none"> - Parking in parallel spaces - Parking fully or partly on kerb stones - Parking on bends - Parking between trees and other obstacles - Length of parking space: Length of vehicle + 0.8m - Parking procedure Single or several stages - Maximum speed when searching for parking space: 40km/h
	Perpendicular parking			<ul style="list-style-type: none"> - Parking in perpendicular spaces - Width of parking space: Width of vehicle + 0.7m - Parking procedure Single or several stages - Maximum speed when searching for parking space: 20km/h
Exiting procedure				<ul style="list-style-type: none"> - Exiting parallel parking spaces - Length of parking space: Length of vehicle + 0.5m - Exiting procedure Single or several stages
Brakingsupport				<ul style="list-style-type: none"> - ESP intervention when parking at excessive speed or if there is a risk of collision to minimise damage



Further information about park assist steering version 1.0 inc. all components can be found in self-study programme no. 389 "Park assist steering".

System design

System layout

To facilitate a function as complex, for example, as park assist steering, various vehicle subsystems work together. The following system layout shows the network in the CAN data bus system.

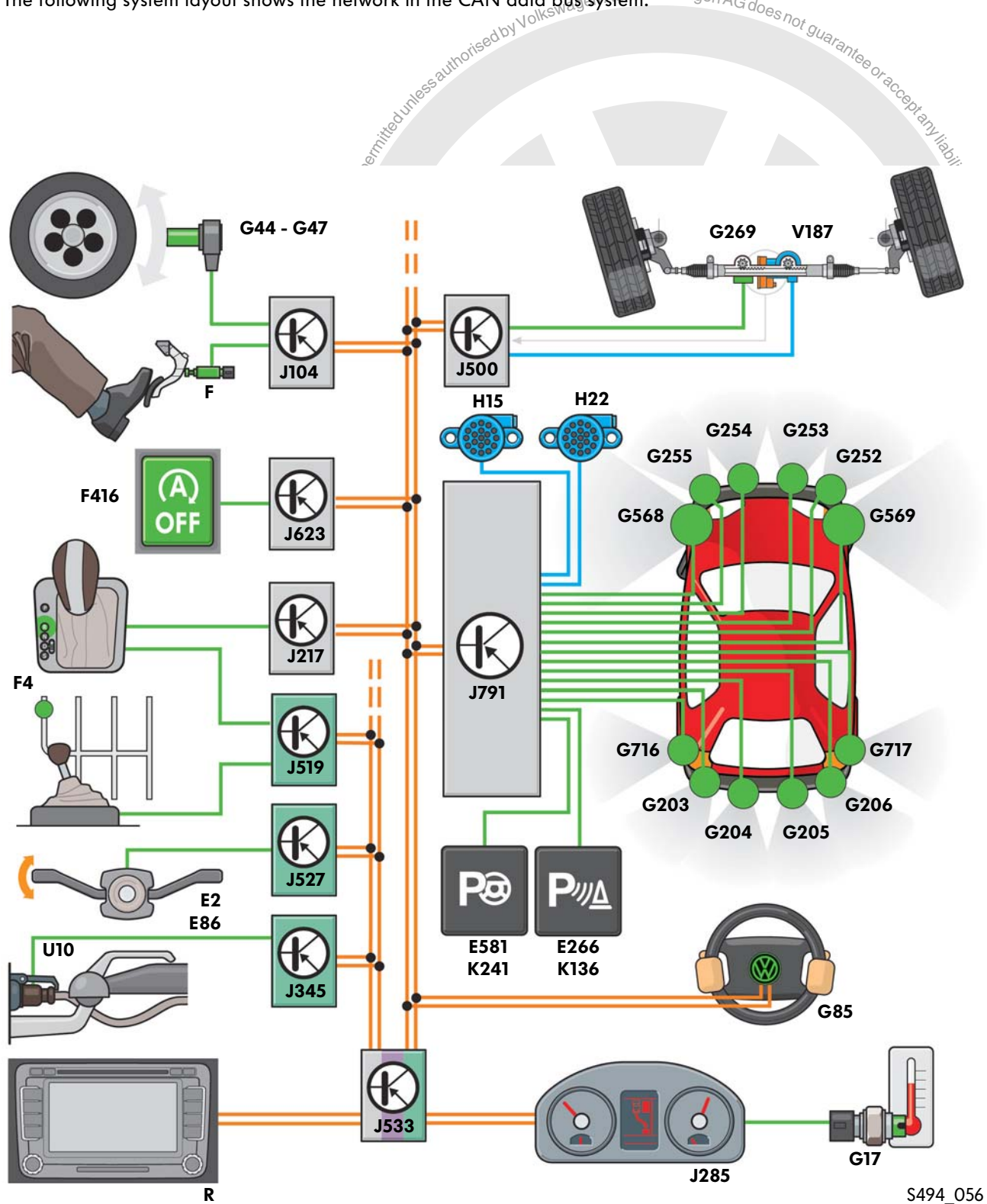

S494_056

Key

Park assist steering

E266	Parking aid button
E581	Park assist steering button
G203	Rear left parking aid sender
G204	Rear centre left parking aid sender
G205	Rear centre right parking aid sender
G206	Rear right parking aid sender
G252	Front right parking aid sender
G253	Front centre right parking aid sender
G254	Front centre left parking aid sender
G255	Front left parking aid sender
G568	Front left park assist steering sender, left side of vehicle
G569	Front right park assist steering sender, right side of vehicle
G716	Rear left park assist steering sender
G717	Rear right park assist steering sender
H15	Rear parking aid warning buzzer
H22	Front parking aid warning buzzer
J791	Control unit for park assist steering
K136	Parking aid warning lamp
K241	Park assist steering warning lamp

Electromechanical power steering

G85	Steering angle sender
G269	Steering moment sender
J500	Power steering control unit
V187	Electromechanical power steering motor

Braking system

F	Brake light switch
G44	Rear right speed sensor
G45	Front right speed sensor
G46	Rear left speed sensor
G47	Front left speed sensor
J104	ABS control unit

Engine and gearbox management

F4	Reversing light switch
F416*	Start-stop button
J217**	Automatic gearbox control unit
J623	Engine control unit
J519	Onboard supply control unit

Dash panel and steering column electronics







E2	Turn signal switch
E86	Multifunction display call-up button
G17	Ambient temperature sensor
J285	Control unit in dash panel insert
J527	Steering column electronics control unit
J533	Data bus diagnosis interface

Trailer detection***

J345	Trailer detector control unit
U10	Trailer socket

Infotainment

R	Radio/radio navigation system
---	-------------------------------

	Powertrain CAN data bus
	Convenience CAN data bus
	Infotainment CAN data bus
	Sensor, input signal
	Actuator, output signal
	CAN data bus line

* Only on vehicles with start/stop system

** Only on automatic vehicles

*** Only on vehicles with tow hitch and trailer detection



Mode of operation

Parking

The process of reverse parking with park assist steering version 2.0 comprises the following stages:

- Parking space measurement
- Park assist steering activation
- Parking manoeuvre with park assist steering support



Parking space measurement

Before the driver can be offered steering support by the park assist steering system, a suitable parking space has to have been measured and the relative position of the vehicle to this parking space must be known.

Even if park assist steering version 2.0 is not activated, the senders (G568 and G569) are always working. This means that while the vehicle is moving forwards at a speed below 40 km/h (parallel parking space) or 20 km/h (perpendicular parking space), all possible parking spaces are measured continually on both sides by the two senders mounted on the front sides of the vehicle. The range of these senders is approx. 4.5 m.

In this case, parking spaces on corners or windy roads are detected and identified as parking spaces under the same conditions as driving in parallel on a straight road. The system detects not only vehicles but also objects. Parking spaces are detected behind an individual object or between two objects.

However, the PDC still issues an acoustic warning as before if the vehicle gets too close to objects in a parking space that are not identified by park assist steering.

The most recent parking space measured on the left and on the right-hand side of the road is always stored temporarily in the park assist steering control unit. The details of the detected parking space are stored until a new parking space is detected or the vehicle has moved too far away from the parking space. Parallel spaces are stored up to approx. 15 m and perpendicular parking spaces up to approx. 8 m from the respective parking space.

If the park assist steering button is pressed within this range, the parking space that the vehicle has passed is stored in the memory. This is indicated in the display of the dash panel insert by an empty space between the shaded rectangles.



If the engine is switched off (e.g. "stalled"), any data stored in the park assist steering control unit is cleared and the parking space measurement must be restarted.

Mode of operation

Parallel parking parameters

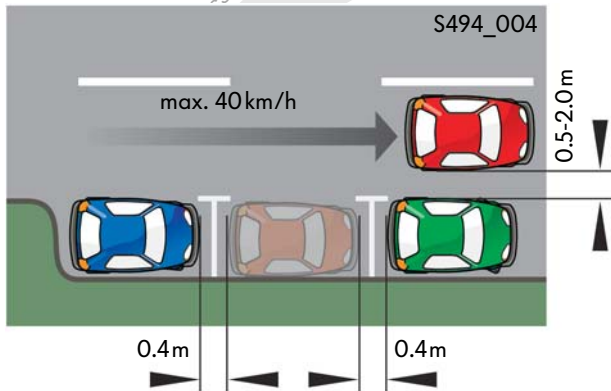

The minimum size of the parking space during parallel parking, which is detected as a vacant parking space during parking space measurement, is the length of the vehicle plus the manoeuvring space and safe distance at the front and rear of at least 0.4m. The drive-by speed is max. 40km/h.

The ideal start position for parallel parking spaces is along the line of drive with a lateral distance from the parked vehicles of 0.5m to 2.0m.

Perpendicular parking parameters

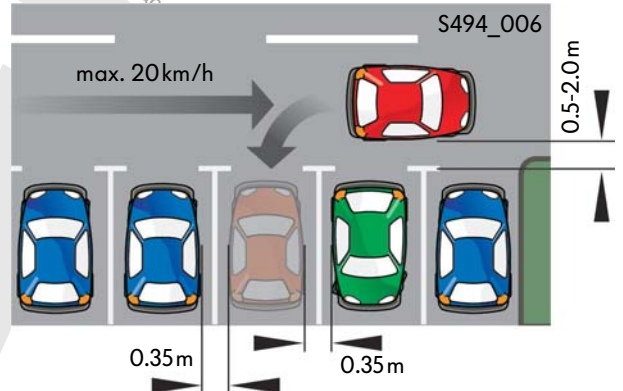

The minimum size of the parking space during perpendicular parking, which is detected as a vacant parking space during parking space measurement, is the width of the vehicle plus the manoeuvring space and safe distance at the left and right of at least 0.35m. The drive-by speed is max. 20km/h.

The ideal start position for perpendicular parking spaces is along the line of drive with a lateral distance from the parked vehicles of 0.5m to 2.0m.

Once the parking space has been detected and is large enough, the park assist steering system requests the driver via the display in the dash panel insert to drive the vehicle past the parking space, if necessary, until the vehicle is in a suitable position from which the parking manoeuvre can be started.

Deactivation of parking space measurement

In a speed range of approx. 40 - 50km/h (for parallel parking spaces) and approx. 20 - 50km/h (for perpendicular parking spaces), the park assist steering system switches to passive mode (standby). The driver is made aware of this via the display in the dash panel insert. If the driver slows the vehicle again to a speed below 40km/h or 20km/h, the sensors become active without him/her having to press the park assist steering button again and the park assist steering system switches to parking space measurement.

From a speed greater than 50km/h, the sensors for parking space measurement are completely deactivated and the data stored up until that point is cleared. The park assist steering must be reactivated.

If the vehicle remains stationary for longer than 30 seconds, the sensors are deactivated temporarily. As soon as the vehicle is driven off, the sensors are reactivated.

Park assist steering activation



S494_052

The park assist steering must be switched on using the park assist steering button E581 prior to every parking manoeuvre. An active function is indicated by the park assist steering warning lamp K241 lighting up in the button.

If a parking space has already been stored in the memory, it will be indicated in the display of the dash panel insert. If no parking space has been detected and stored, the driver is requested to drive further forwards.



Pressing the park assist steering button repeatedly allows selection from the following functions during the parking manoeuvre.

- 1st press of button = park assist steering is activated and display automatically shows image for parking in parallel parking spaces on right-hand side.
- 2nd press of button = display automatically shows image for parking in perpendicular parking spaces on right-hand side.
- 3rd press of button = park assist steering is switched off.



If the driver wishes to park on the left-hand side, he/she merely has to set the left turn signal to change the system over once the park assist steering button has been pressed. In all instances, the park assist steering system assumes on a LHD vehicle that parking should take place on the right-hand side. In this case, no further input is required in principle from the driver. (On a RHD vehicle, the left-hand side of the road is preset).



If the vehicle is equipped with a start-stop system, the engine does not switch to stop mode with park assist steering active.

Mode of operation

Parking manoeuvre with park assist steering support

Once a suitable parking space has been measured and the vehicle is in an appropriate start position, the parking manoeuvre can commence. The driver starts the automatic parking process by engaging reverse gear when the vehicle is stationary and drives off after a stationary period of approx. 0.5 seconds. The stationary period is the time window between engaging reverse gear and actually driving off. During this time, all systems engaged in the process are activated and the ideal path is calculated.



During the automatic parking process, the driver should not apply any turning force on the steering wheel. The park assist steering takes over the steering support, i.e. it steers the vehicle along the calculated path into the parking space. During multi-stage parking, the driver is requested to drive forwards or backwards by images in the display of the dash panel insert. Both rear speed sensors G44 and G46 determine whether the vehicle moves forwards or backwards.

When reverse gear is engaged, the four (two front and two rear) side park assist steering senders for distance monitoring are employed in addition to the eight parking aid senders (four at the front and four at the rear). At the end of the parking process, a message is shown in the display of the dash panel insert that steering support is complete.

If, during steering support, a condition is detected in which the vehicle is compromised or the driver grabs the steering wheel, steering support is cancelled.

Parking in parallel spaces

The driver selects the parallel parking function by pressing the park assist steering button. The images are shown accordingly in the display of the dash panel insert.

Parallel parking can take place in several stages.

The parking speed

- from the start position to entry into the parking space is max. 9 km/h (straight line).
- while entering the parking space is max. 7 km/h (once the steering turns).

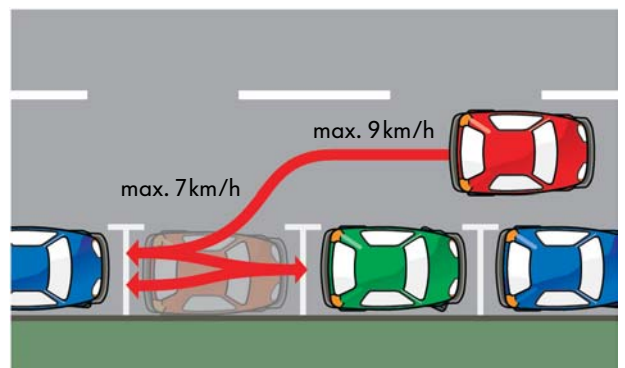

S494_010

Parking between other obstacles

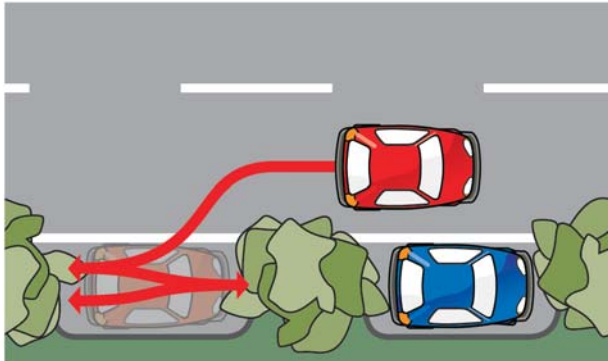

S494_014

With park assist steering version 2.0, not only vehicles but also other objects are detected. Objects serve on one hand to aid orientation, such as sides of houses, walls or kerb stones. On the other hand it is possible to park between objects, for example between trees, refuse bins, bushes or motorbikes.

If a kerb stone is detected, the system uses it as an orientation aid to park the vehicle approx. 15cm from the kerb stone.

If no kerb stone is detected, the vehicle is steered to align with the vehicle parked in front of the obstacle.



Parking fully or partly on kerb stones

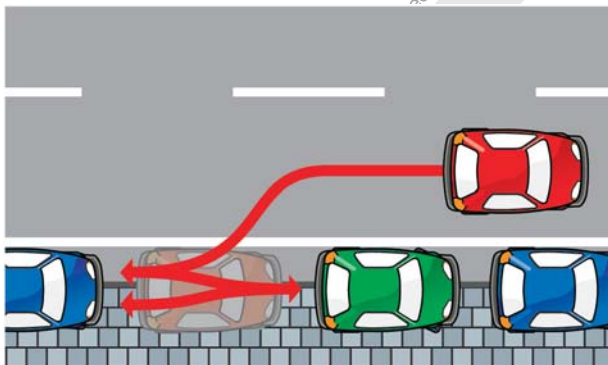

S494_012

The system generally detects edges of kerbs as well as the distance to the edge of a kerb. Furthermore, the parking space length and also parking space depth are measured depending on the position of any vehicles/obstacles located there.

Park assist steering always orientates itself around parked vehicles (vehicle-orientated) during parking. If these are parked half on the kerb stone, parking half on the kerb stone is also possible.

If 2 cars are parked in different manners, for example one vehicle half on the pavement and another on the kerb, the vehicle to be parked is aligned with the vehicle parked in front.

Protected by copyright. Copying for private or commercial use without the prior written permission of Volkswagen AG is prohibited. Volkswagen AG does not guarantee or accept any liability with respect to the content of this document. Copyright by Volkswagen AG.

Mode of operation

Parking on bends

Even parking on bends is possible.

Parking spaces on corners or winding roads with radii above 20m are detected under the same conditions as driving in parallel on a straight road.

The bend radius is used to calculate the ideal path and the final park position.

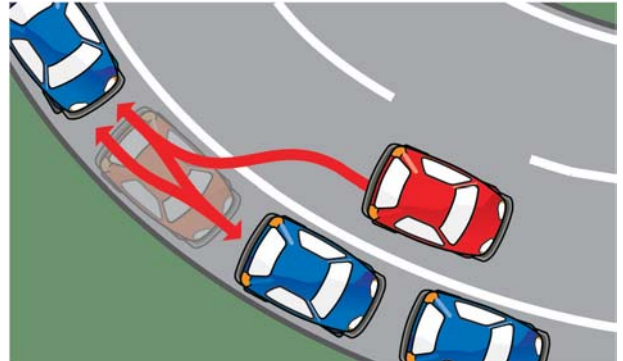

S494_016

Parking in perpendicular spaces

The driver selects the perpendicular parking function by pressing the park assist steering button.

The images are shown accordingly in the display of the dash panel insert.

Perpendicular parking can take place in several stages. The system parks the vehicle centrally in order to make ease of opening the doors equal on both sides.

The rear senders G716 and G717 mounted on sides of the vehicle are intended mainly for the purpose of aligning the vehicle centrally in the parking space. However, they also warn of obstacles in the same range as other PDC sensors.

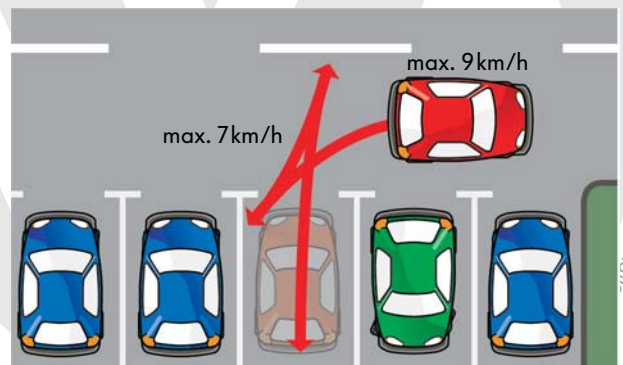

S494_008

The parking speed:

from the start position to entry into the parking space is max. 9 km/h (straight line).

- while entering the parking space is max. 7 km/h (once the steering turns).

Brake assistance

The brake assist feature has two functions:

- Brake intervention if parking speed is exceeded
- Bring vehicle to halt if there is a risk of collision with detected obstacle to minimise damage

Brake intervention when parking

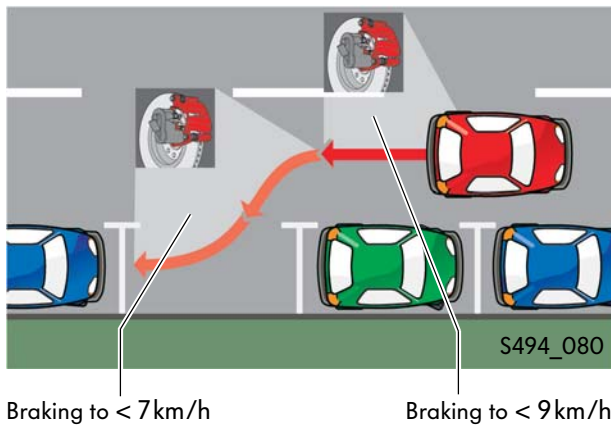

If the vehicle is driven above a speed threshold of $v > 9\text{ km/h}$ (straight line) or $v > 7\text{ km/h}$ (while entering the parking space) the park assist steering requests an intervention of the ESP system to reduce the speed. The parking process can be continued, i.e. park assist steering remains active. If, despite this, the vehicle still exceeds a speed of 10 km/h , park assist steering will be cancelled.



Braking to a halt

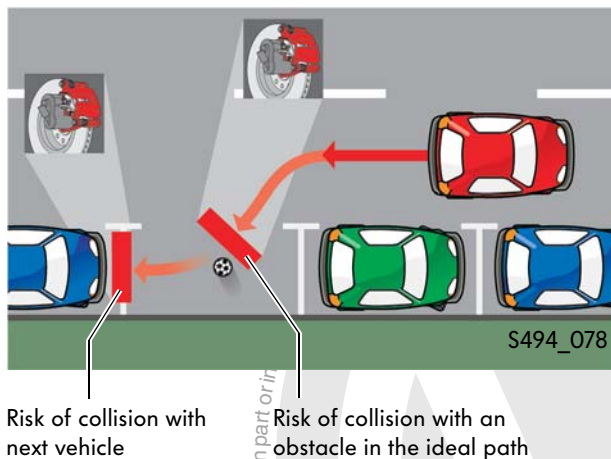

Park assist steering will initiate a braking manoeuvre to a stop if, after the parking process has started, an obstacle is detected in the ideal path, the driver does not brake in good time and park assist steering detects a risk of collision with this obstacle. This function is only possible, however, if the speed does not fall below the minimum "crawling threshold" of about 1.5 km/h . The vehicle is brought to a halt using the brakes and the automatic parking process is stopped. If park assist steering is to be used again as an aid to parking, a new parking space search has to be started.







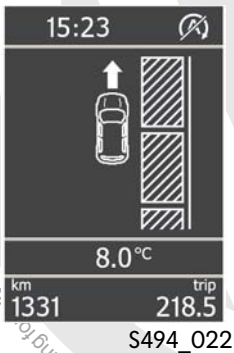
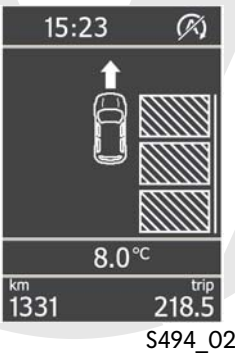
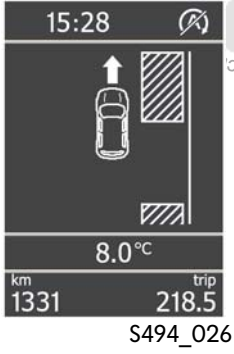
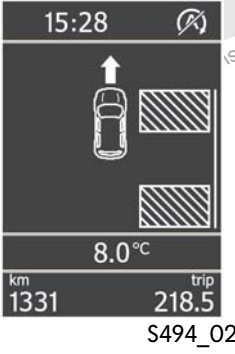

Braking to a halt by the park assist steering system serves purely to minimise damage and reduce the impact of an accident. It is therefore not a safety system as such. Under optimal conditions, an accident can be avoided but guaranteeing a stop before obstacle collision is not possible. The driver always maintains responsibility for accelerating, clutch control and braking.

Mode of operation

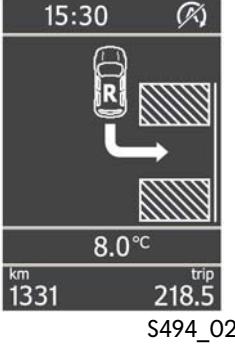
Images in display of dash panel insert

During parking, the driver is supported by numerous prompts. With the audible signals from park distance control and the driving instructions in the display of the dash panel insert, he/she is guided into place. The driver is shown the following information during parking:

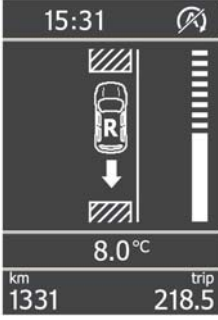
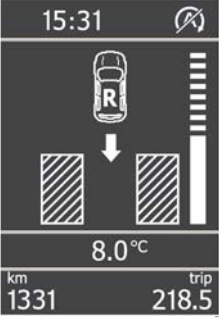
Parallel parking	Perpendicular parking	Description
		Parking space search No parking space found and no parking space in memory of park assist steering system. The driver is requested to drive further forwards.
		Adjust position Parking space found but vehicle start position inadequate for parking process. The driver is requested to drive further forwards.
		Park assist steering ready Parking space found and optimal vehicle position attained. The driver now has to bring vehicle to a halt using the brakes, engage reverse gear and start driving, taking account of stationary period (0.5sec.).

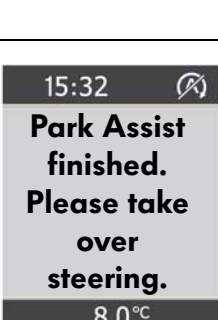
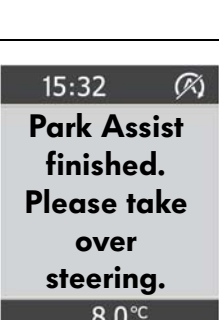
Parallel parking	Perpendicular parking	Description
 <p>S494_034</p>	 <p>S494_032</p>	<p>Steering support activated</p> <p>"Steering intervention active. Check area around vehicle." shown in the display of the dash panel insert indicates to the driver that steering intervention has started and the driver must watch the area around the vehicle should the parking process need to be stopped in case of doubt or due to a hazard.</p>
 <p>S494_038</p>	 <p>S494_036</p>	<p>Request to drive backwards</p> <p>Park assist steering takes over steering of the vehicle once reverse gear is engaged (steering support), i.e. it steers the vehicle along a calculated path into the parking space. The progress bar indicates how far away the vehicle is from the end of the parking space.</p>
 <p>S494_042</p>	 <p>S494_040</p>	<p>Request to drive forwards</p> <p>If a warning signal sounds permanently or the progress bar is empty, an instruction to brake and to change the direction of travel is given. Since with every gear change the steering system turns the wheels when stationary to the required steering angle, the instruction is given to keep the foot on the brake during this process. This instruction takes the form of a foot brake symbol. The driver can make a change in direction at any time by selecting the relevant gear.</p>
 <p>S494_044</p>	 <p>S494_044</p>	<p>Steering support ended</p> <p>Once the vehicle is aligned optimally in the parking space, the parking process is complete and a message is shown in the display of the dash panel insert "Park Assist finished. Please take over steering." In addition to the display, a gong sounds.</p>



Mode of operation

The exiting procedure

The process of exiting parallel parking spaces forwards with park assist steering version 2.0 comprises the following functions:

- Park assist steering activation
- Parking space measurement
- Exit parking space with park assist steering support



Park assist steering activation

The park assist steering must be switched on using the park assist steering button E581 prior to every exit manoeuvre. To access exit mode, the vehicle must not have been driven after the ignition was switched on, i.e. the vehicle must not have been moved. Pressing the park assist steering button repeatedly allows selection from the following functions during the exit procedure.

- 1st press of button = park assist steering is activated for exiting.
- 2nd press of button = park assist steering is switched off.

An active function is displayed by the park assist steering warning lamp K241 lighting up in the button. In the display of the dash panel insert, the instruction "Activate turn signal, engage reverse gear" is shown.

Parking space measurement

For the exiting procedure, only the 4 PDC sensors on the front and rear bumpers are used. They determine the distance to the vehicle parked at the front and rear or to an obstacle. The minimum size of the parking space for exiting is the length of the vehicle plus the manoeuvring space and safe distance at the front and rear of at least 0.25m.

Exiting parking space with park assist steering support

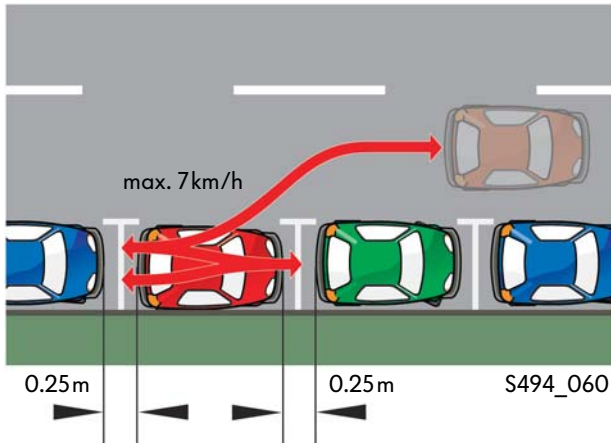

Once the park assist steering button is pressed and the parking space position is measured, the exiting procedure can start.

The driver starts the automatic exiting procedure with the vehicle stationary by activating the turn signal, engaging reverse gear and driving off. The turn signal indicates from which direction the parking space should be exited.

The driving instructions in the display of the dash panel insert (as with parking) should now be followed. This occurs in several stages (forwards/backwards) until the system hands over to the driver.

If, during steering support, a condition is detected in which certain determination of the vehicle position is compromised or the driver grabs the steering wheel, steering support is cancelled.

Once park assist steering detects that it is possible at the next exiting stage to drive past the front boundary object with the steering angle it has set, it completes the procedure and steering is handed back to the driver.



Exiting from perpendicular parking spaces with park assist steering version 2.0 is not technically possible.



The driver must watch the traffic during the exiting procedure!

Brake assistance

The ESP system even intervenes during the exiting procedure (as with parking) if the exit speed exceeds 7 km/h. Braking to a halt is also executed if there is a risk of collision with a detected obstacle to minimise damage.

Mode of operation

The system limitations

The measurement of the parking space and the subsequent parking procedure can be influenced by the surrounding conditions. For example, the system does not detect

- drain covers
- depressions and unsecured road shoulders
- small obstacles in the parking space

Potential physical limitations of the ultrasound sensors could impair operation to a certain degree, such as

- dirty sensors
- drops of rain on sensor membranes
- snow and ice on sensors
- heavy rain or snow fall
- strong wind

For example, park assist steering could have problems in recognising a kerb stone if leaves, rubbish or snow make its shape difficult to determine. In addition, leaves and snow cause the ultrasound signals to scatter much more due to reflection. Consequently, park assist steering may record no ultrasound echo, which can lead to misinterpretation.

Another example for the limitations of the system are forks or junctions in the road or driveways. What the park assist system believes to be an ideal parking space may, upon closer examination, turn out to be a driveway with closed gates.



These limitations underline the fact that the park assist steering system cannot substitute the driver's concentration. Responsibility remains with the driver.



System errors or physical malfunctions are indicated by a message in the display of the dash panel insert. Some of the system errors and physical malfunctions are described in the operating instructions of the vehicle.

How subsystems work

Various vehicle subsystems work together with the park assist steering in order to perform the park assist steering function. Involved are the following subsystems:

- the electromechanical power steering
- the braking system with ABS and ESP
- the engine and gearbox management
- the dash panel and steering column electronics
- the trailer detection (if fitted)
- the Infotainment system
- the electric sliding doors

Electromechanical power steering

Electromechanical power steering is a main prerequisite for the installation of park assist steering. It enables the park assist steering control unit to steer actively and autonomously with the aid of the electric drive system of the power steering.

The parking aid control unit J500 is responsible for actuation of the steering. The steering moment sender G269 detects any driver intervention on the steering and cancels the parking process immediately.



Detailed information can be found in self-study programme no. 317 "Electromechanical power steering with double pinion" and no. 389 "Park assist steering".

Braking system

The ABS control unit J104 provides the vehicle speed information and, if excessive, reduces the speed during parking to below 7km/h or 9km/h. If there is a risk of collision, ESP intervenes to stop the vehicle and park assist steering is switched off.

Both rear speed sensors G44 and G46 are capable of detecting the direction of rotation. From these senders the park assist steering system receives the path details and information about whether the vehicle is moving forwards or backwards.



Mode of operation

Engine and gearbox management

The automatic gearbox control unit J217 detects which gear is engaged.

The onboard supply control unit tells park assist steering when reverse gear is engaged.

If the vehicle is equipped with a start/stop system, the engine control unit ensures with active park assist steering that the engine does not stop.



Dash panel and steering column electronics

The control unit in the dash panel insert J285 is responsible for displaying parallel and perpendicular parking spaces on the left or right-hand side of the road, instructions to change direction, instructions to brake, the gong and the process continuity during multi-stage parking.

The outside temperature is transmitted by the ambient temperature sensor G17 to the control unit in the dash panel insert. It has an influence on the calculation of measured distances to obstacles because the air density changes and, consequently, the propagation speed of ultrasound waves.

Turn signal switch E2 is used to detect on which side of the road the vehicle is to be parked. The signal is passed on via the steering column electronics control unit J527 and the images are shown in the display of the dash panel insert accordingly.

Trailer detection

If a connector is detected in the trailer socket U10, the park assist steering system cannot be activated.

Infotainment

In the radio/radio navigation system, park distance control or reversing camera images and also obstacles are displayed by the park assist steering system even during the parking process. The volume limit for sound output can be adjusted while the park assist steering system is active.

Sliding doors

On vehicles with electric sliding door, park assist steering is switched off if the door is actuated.

The sensors

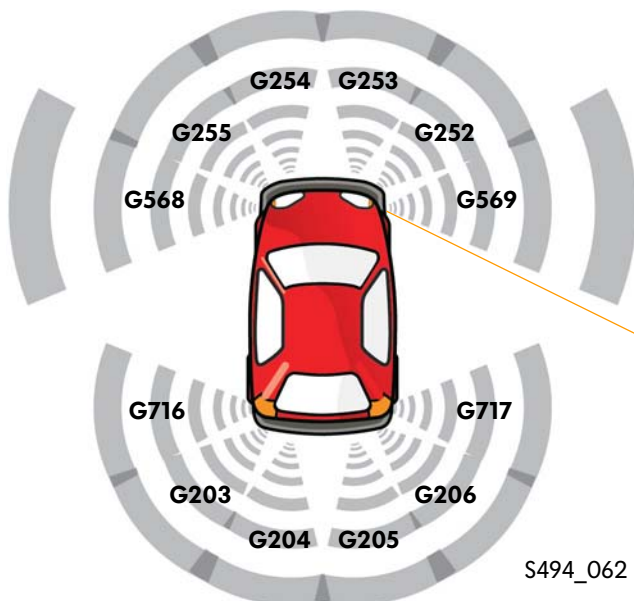

Vehicles with park assist steering version 2.0 feature the following sensors:

- Park assist steering sender
- Parking aid sender

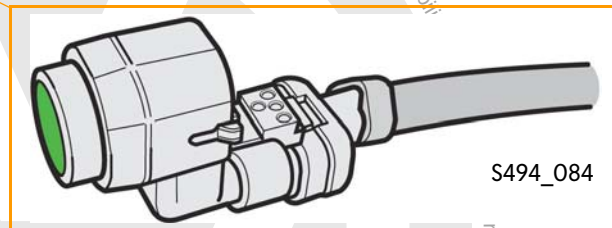

Park assist steering senders

- Two lateral ultrasound sensors in front bumper for measuring parking spaces
 - Front left sender for park assist steering on left side of vehicle G568
 - Front right sender for park assist steering on right side of vehicle G569
- Two lateral ultrasound sensors in rear bumper for controlling safe distance and correct alignment in parking space during perpendicular parking
 - Rear left park assist steering sender G716
 - Rear right park assist steering sender G717

Parking aid senders

- Four ultrasound sensors for park distance control in front and rear bumper respectively
 - Rear left parking aid sender G203
 - Rear centre left parking aid sender G204
 - Rear centre right parking aid sender G205
 - Rear right parking aid sender G206
 - Front right parking aid sender G252
 - Front centre right parking aid sender G253
 - Front centre left parking aid sender G254
 - Front left parking aid sender G255



Further information about the function of ultrasound sensors can be found in self-study programme no. 389 "Park assist steering".

Electrical components

The park assist steering senders

The park assist steering senders G568, G569, G716, G717 are ultrasound sensors. They are inserted from behind into a retainer, which is clipped into the plastic cover of the front and rear bumper.

Signal use

The signals of both park assist steering senders G568 and G569 are housed in the front bumper. They are used for the steering function.

On one hand they are used to measure potential parking spaces and, on the other, to monitor lateral distances to the front vehicle and obstacles during the parking process.

The signal is used in the calculation of the drive-by angle.

The signals of both park assist steering senders G716 and G717 are housed in the rear bumper. They measure the actual width and position of the parking space during perpendicular parking.

The signal is used in the calculation to park the vehicle centrally.

It is also used to monitor lateral distances to obstacles during the parking process.

Effects of failure

The sensors are capable of diagnosis. If one of the sensors is faulty, the park assist steering function will not be available.

The parking aid senders

The parking aid senders G203, G204, G205, G206, G252, G253, G254, G255 are ultrasound sensors and are inserted from behind in the plastic cover of the front and rear bumper. Their function mirrors that of the park assist steering senders. The senders are located so that their scanning areas overlap slightly. There is therefore no "dead" area where obstacles cannot be detected.

Signal use

The signals of the sensors are used both for park distance control and the park assist steering function. Both functions involve scanning the distance of the vehicle to other obstacles around the vehicle.

Effects of failure

All eight sensors are capable of diagnosis. One defective sensor leads to failure of the whole system. Failure of the park assist steering function caused by technical defects in participating components is indicated by flashing of the warning light at a speed range up to 50 km/h.

Park assistant steering button E581 with park assist steering warning lamp K241



The park assist steering button E581 can be found on the Touran, for example, in the row of buttons above the selector lever. Several function statuses can be selected with the button. The park assist steering warning lamp K241 indicates that the park assist steering function is active when yellow.

Signal use

If the vehicle has already moved a distance after the ignition was switched on, the button will be in "parking" mode. Pressing the park assist steering button several times makes it possible to toggle between the following functions:

- 1st press of button = park assist steering is activated for parallel parking.
- 2nd press of button = function for perpendicular parking is activated.
- 3rd press of button = park assist steering is switched off.

Pressing the button again would result in a new sequence as with the first press of the button. Running through the functions does not lead to the memory being cleared despite deactivation of the park assist steering, i.e. tagged parking spaces are still stored.

If the vehicle has not been driven after the ignition was switched on, i.e. no distance travelled, the button will be in "exit" mode. Pressing the park assist steering button repeatedly allows selection from the following functions during the exit procedure.

- 1st press of button = park assist steering is activated for exiting parallel parking spaces.
- 2nd press of button = park assist steering is switched off.

Effects of failure

Failure of the park assist steering function caused by technical defects in participating components is indicated by the flashing of the park assist steering warning lamp K241.



Electrical components

Parking aid button E266 with parking aid warning lamp K136

Parking aid button E266 can be found in the Touran, for example, in the row of buttons above the selector lever on the right next to the park assist steering button. The parking aid warning lamp K136 indicates that the function is active when yellow.

Signal use

The button is used to manually activate the parking aid (park distance control), e.g. when parking forwards.

Effects of failure

Failure of the parking aid function caused by technical defects in participating components is indicated by the flashing of parking aid warning lamp K136 in a range up to 10km/h or display of the fault when reverse gear is engaged.

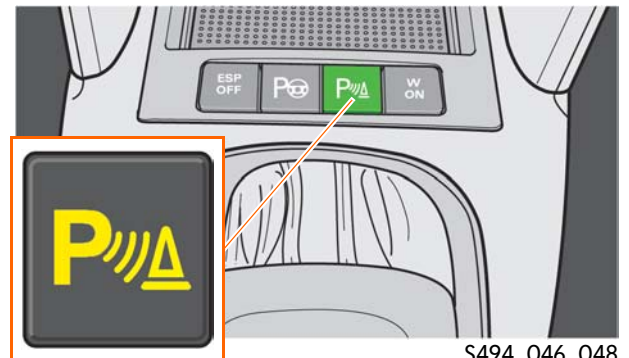

The actuators

Rear parking aid warning buzzer H15 Front parking aid warning buzzer H22

The parking aid emits acoustic signals via the buzzer. The interval between these signals tells the driver how far away the vehicle is from an object during parking.

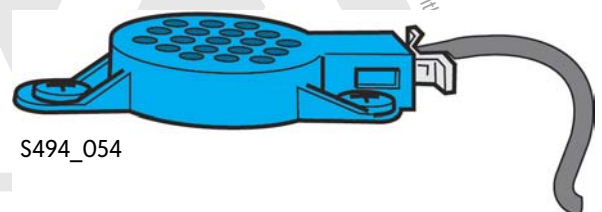

Further information about the warning buzzers can be found in self-study programme no. 389 "Park assist steering".

System management

The control unit for park assist steering J791

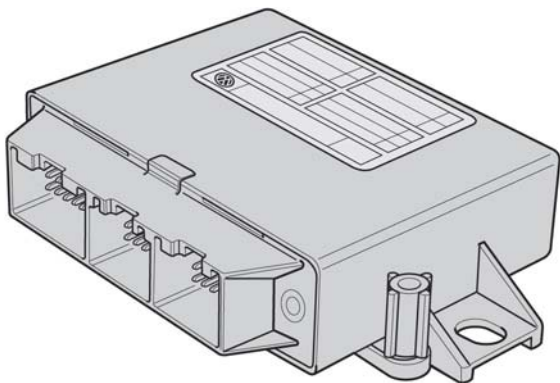

S494_064

The park assist steering control unit J791 is responsible for the parking and exiting procedure and for the park distance control (parking aid) distance warning. It also co-ordinates the display of the OPS and the reversing camera image in the display of the radio or navigation system.

If the vehicle is equipped with park assist steering, the park assist steering control unit J791 also includes the functions of the parking aid control unit.

If a vehicle is equipped with park distance control and thereby a parking aid control unit, there is no provision to allow the park assist steering function to be added.



Diagnosis

The new park assist steering system is compatible with vehicle diagnosis, testing and information system VAS 5051 and vehicle diagnosis and service information systems VAS 5052 and VAS 5053.

These systems can be used to call up the individual sensors during diagnosis communication with the park assist steering control unit J791 in "Read measured values", for example, thereby enabling display of the calculated distance to obstacles.

By simulating an obstacle (for example walking around in close vicinity), a simple test of the sensors' functionality can be carried out.

The self-diagnosis for physical sender malfunctions caused by water, ice, snow, etc., is realised by determining the period it takes the membrane to respond and settle.

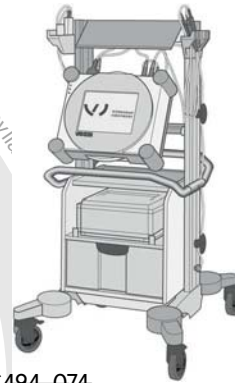

S494_074



S494_072



S494_070



Painting and installation regulations

The membrane oscillates in the ultrasound range and also needs to oscillate during the reception of reflected sound waves. The decoupling ring prevents foreign material contact to the bumper.

The following must be observed to prevent sensor malfunctions:

- Do not squeeze decoupling ring. Install without force.
- Bond sender retainer in bumper centrally to hole so that no excessive lateral pressure is imparted on the sender.
- Drill sufficiently sized hole in bumper and deburr edges.
- Only apply paint in required thickness so that no excessive lateral pressure is imparted on the membrane and oscillation is not too weak.
- Fit sender without tension.
- Paint sender separately to avoid any bridging of the component to the bumper via the paint.

Country-specific information

The park assist steering system has to be configured differently for left-hand traffic and right-hand traffic. The setting is made via the left-hand drive/right-hand drive coding on VAS 5051.

Here, information stored in the park assist steering control unit (as well as other information) for parking on the left or right-hand side of the road is reversed.

This means, for example, that drivers in the United Kingdom need to set the turn signal to "Right" if they want to park on the right-hand side of the road. By default, the system presumes that the vehicle should be parked on the left-hand side of the road if the coding is set to right-hand drive.

In Germany, drivers need to set the turn signal to "Left" because the system presumes they want to park on the right-hand side of the road by default due to the left-hand drive coding.



Ensure that the coding is correct if the vehicle is to be used for any period of time in a country where the traffic system is different, e.g. left or right-hand drive coding.

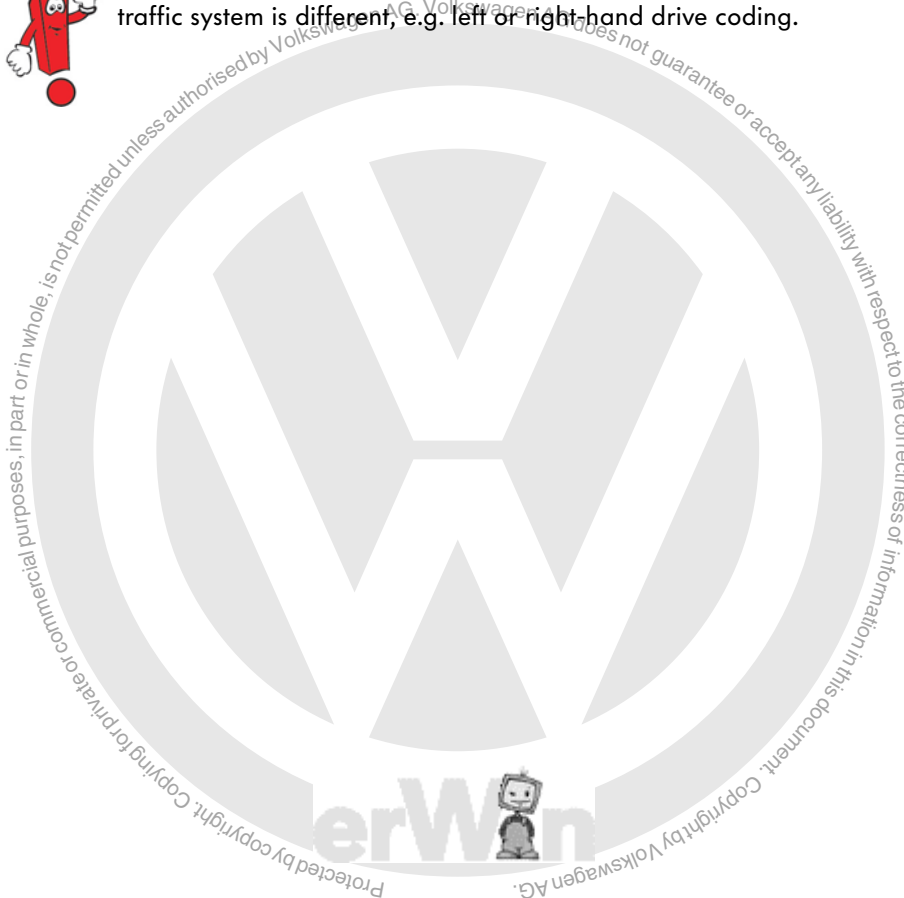

Test your knowledge

Which answer is correct?

One or several of the answers could be correct.

1. Which statement is true?

- a) The park assist steering function takes over the complete parking process fully automatically. The driver is not required to do anything anymore during parking.
- b) The park assist steering function only takes over control of the distances to obstacles around the vehicle during parking.
- c) The park assist steering function takes over the steering when reverse parking to the left or right. The driver still has to press the brake, clutch and accelerator pedals and maintains responsibility during the whole process.

2. Which functions can be performed with the park assist steering system?

- a) Park distance control (parking aid)
- b) Measurement and display of parking spaces on both sides of the road at the same time
- c) Measurement of parking spaces with inactive park assist steering
- d) Measurement of parking spaces with active park assist steering
- e) The steering when parking forwards into parallel and perpendicular parking spaces
- f) The steering when parking backwards into parallel and perpendicular parking spaces
- g) The steering when exiting from parallel parking spaces

3. Above which speed does the park assist steering system cancel the measurement of a parallel parking space and switch to stand-by mode?

- a) From a speed of 50 km/h
- b) From a speed of 20 km/h
- c) From a speed of 40 km/h

4. Brake intervention on the park assist steering system occurs:

- a) if the parking speed of max. $v = 9\text{ km/h}$ or max. $v = 7\text{ km/h}$ is exceeded.
- b) if the "crawling speed" of about 1.5 km/h is exceeded.
- c) if, when entering a parking space at a speed of max. 7 km/h and at least 1.5 km/h , an obstacle in the ideal path is detected, the driver does not brake in time and a risk of collision with an obstacle is detected by the park assist steering system.
- d) if it appears there is a risk of the vehicle veering off the calculated path. The vehicle is braked as a warning to alert the driver's attention to the driving situation.

5. The vehicle has already been moved after the ignition was switched on.

Between which functions is it possible to toggle by repeatedly pressing the park assist steering button?

- a) Activation of parking space measurement, activation of parking function, deactivation
- b) Activation of parking function, activation of exiting procedure, activation of automatic brake intervention
- c) Activation of parallel parking function, activation of perpendicular parking function, deactivation

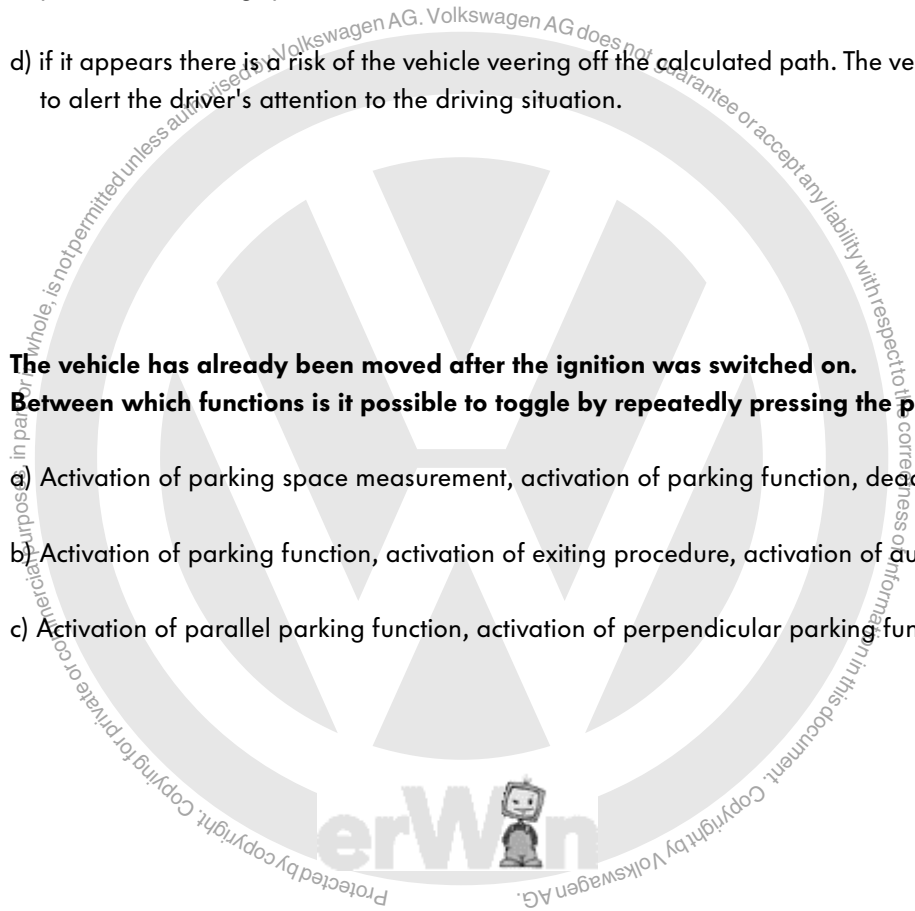

- Answers**
- 1. c);
 - 2. a), c), d), f), g);
 - 3. c);
 - 4. a), c);
 - 5. c)

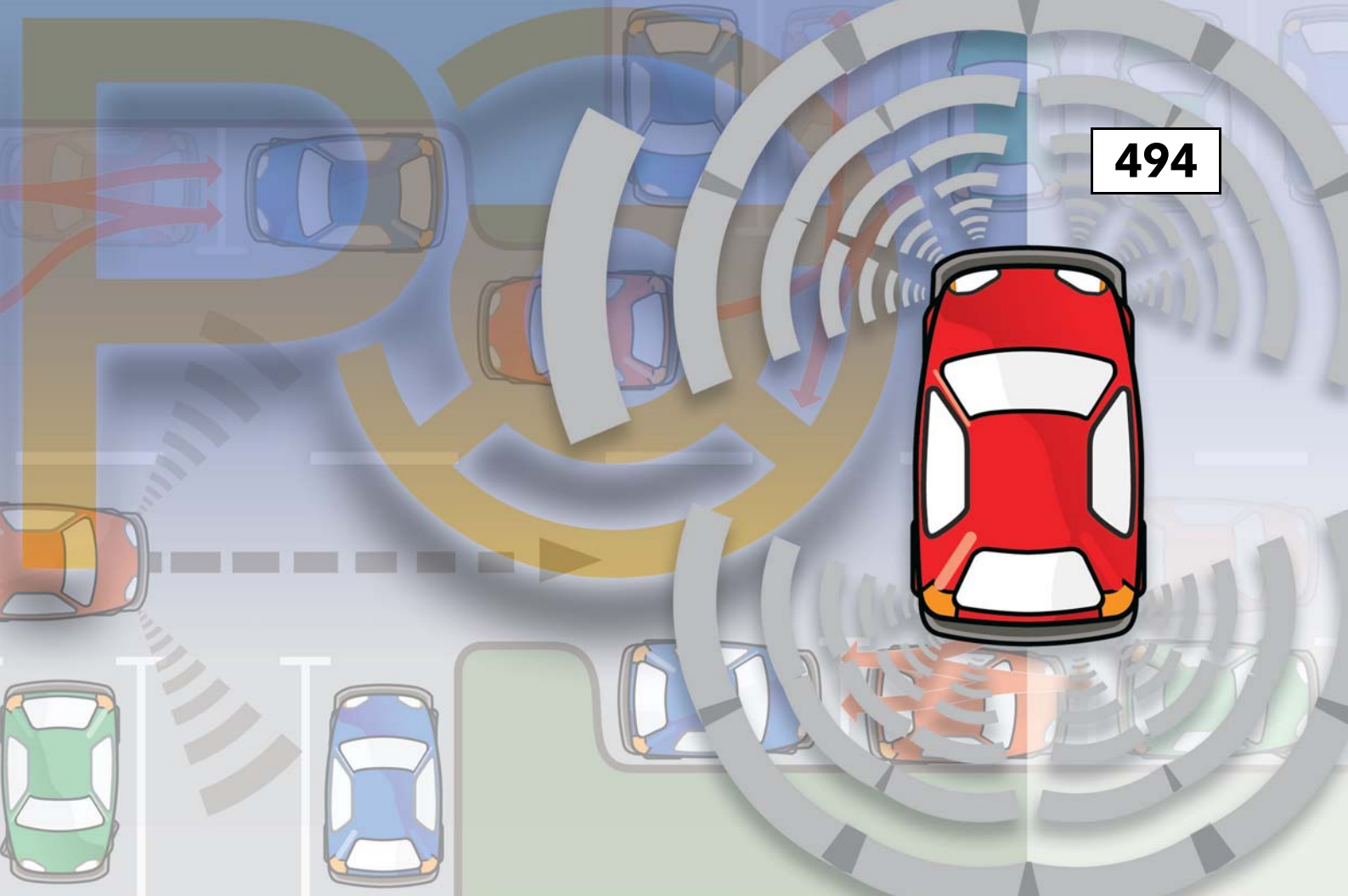

© VOLKSWAGEN AG, Wolfsburg
All rights and rights to make technical alterations reserved.
000.2812.51.20 Technical status 12.2010

Volkswagen AG
After Sales Qualification
Service Training VSQ-1
Brieffach 1995
D-38436 Wolfsburg

♻️ This paper was manufactured from pulp that was bleached without the use of chlorine.