

Service Training

Self-study Programme 342

Radio Systems 2006

Design and Function

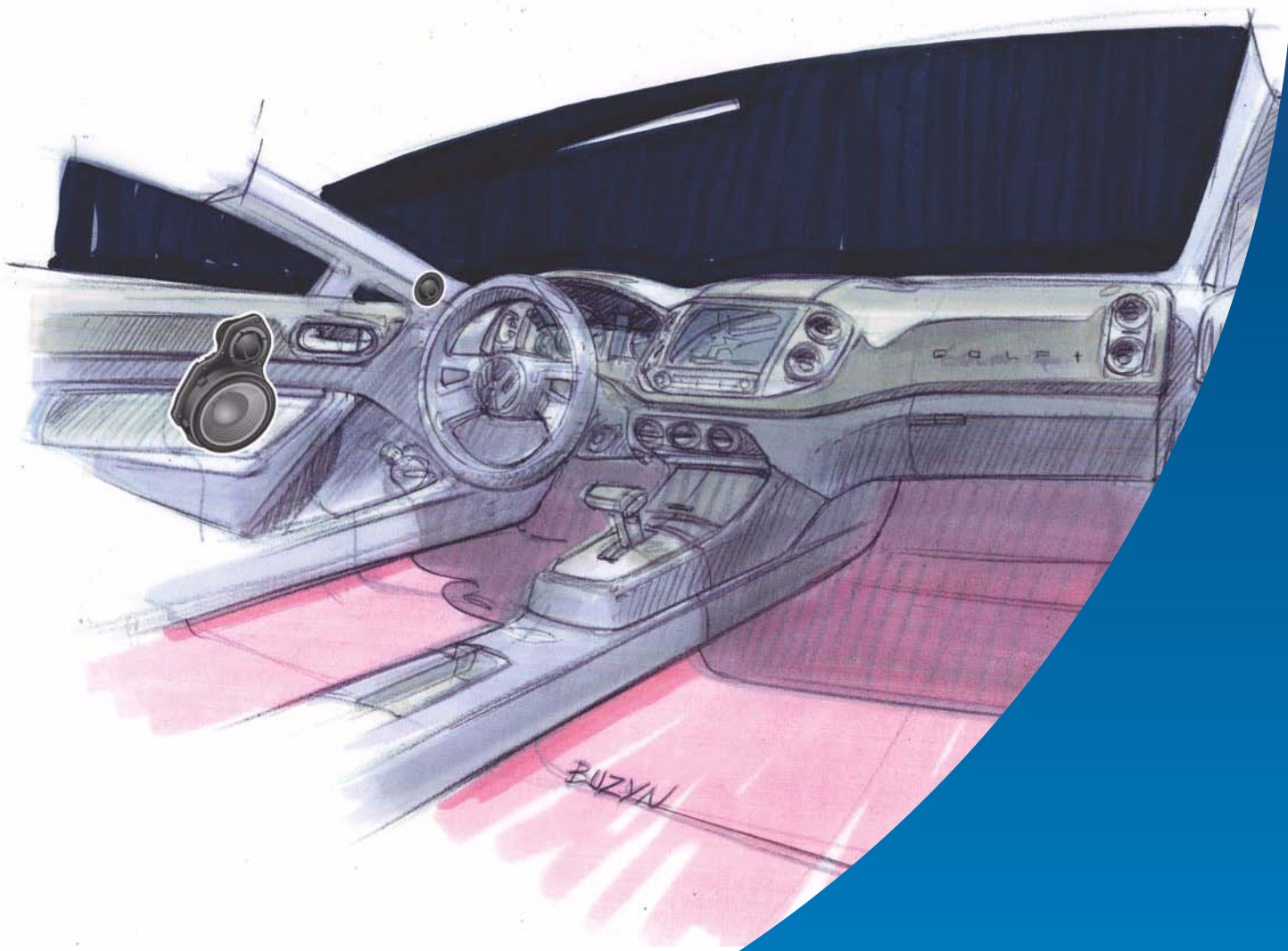

Radio broadcasts are not just for entertainment. They are an important source of information in vehicles, in particular, that provide traffic news in addition to music and general information. New products are constantly required in the area of radio receivers in order to meet current and future requirements.

This self-study programme was compiled with the valuable help of Blaupunkt GmbH in Hildesheim. It should help you understand the audio technology used in Volkswagen vehicles as a supplement to self-study programme 147.

Commercial purposes, in part or in whole, is not permitted unless authorised by Volkswagen AG. Volkswagen AG does not guarantee or accept any liability with respect to the correct

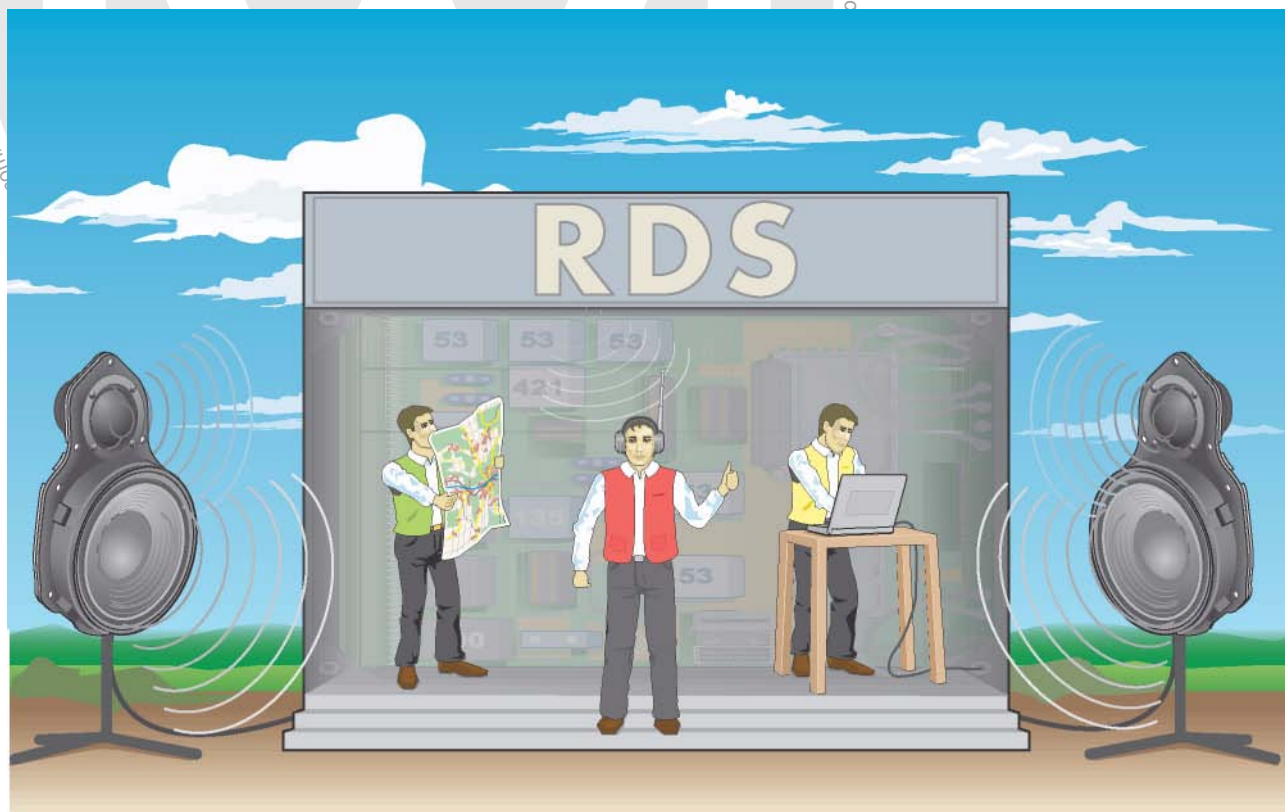

S342_055

NEW



Important Note



The self-study programme shows the design and function of new developments. The contents will not be updated.

For current testing, adjustment and repair instructions, refer to the relevant service literature.



Basics	
Radio reception in FM range	4
Aerial properties	6
Audio CD (Audio Compact Disc)	12
Handling and care information for CDs and CD-ROMs	14
Moving Picture Experts Group (MPEG) MP3	15
Digital Audio Broadcasting (DAB)	16
Radio Systems	
R 100 radio	18
RCD 200 radio	22
RCD 300 radio	26
RCD 500 radio	30
Sound Systems	
8-channel analogue amplifier	34
10-channel digital amplifier	36
12-channel digital amplifier	38
10-channel DYNAUDIO high-end system	40
Digital Signal Processing (DSP)	42
Loudspeaker locations	44
Aerial systems	
Aerial systems for the Golf/Golf Plus	46
Aerial systems for the Passat 2006 and Jetta 2006	51
Aerial connection systems	54
Glossary	56
Test Yourself	58





Radio reception in FM range

FM waves travel in straight lines. They are not reflected by the layers of the earth's atmosphere and therefore do not follow the curve of the earth.

You obtain the best reception when the broadcasting aerial can "see" the car aerial.

The FM signals, which are transmitted by the transmitter with horizontal or vertical polarisation (depending on country), can be received best with an aerial that is mounted in a position that can be reached from all sides (the signals "see" the full length of the aerial).

Disadvantage: The range is lower than AM signals (MW, LW).

If you leave the range of the transmitter tower (the sound quality will become poor and there is sound interference), a new transmitter or a different frequency needs to be selected.

On car radios with RDS (Radio Data System), an alternative frequency is searched for automatically.



S342_001



S342_004

FM waves cannot pass through hills, buildings and similar obstacles without being impaired. If the vehicle enters such an area, only poor or no reception is possible. This occurs in particular when you drive through mountains or between high-rise buildings. The range depends on the transmission power and the distance of the transmitter aerial from the ground. Transmitter aeriels are therefore normally placed on towers, tall buildings or mountains.

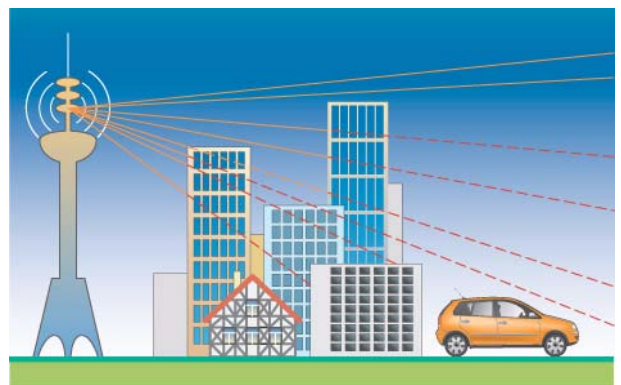

S342_002



FM waves are reflected by building, hills etc. Reception from several directions results (multipath).

This can cause the direct signal to be deflected even in covered areas like, for example, built-up areas or mountains. This reflection could cause reception to be poor quality (reflection surface).

In some cases, the radio tuner picks up both the direct and also a reflected signal from the transmitter. This overlapping of the direct and reflected (delayed) signals can cause reception interference in the form of audible sound distortion in the speaker. Furthermore the time difference between the direct and indirect signal causes the reception quality to vary depending on the vehicle position.

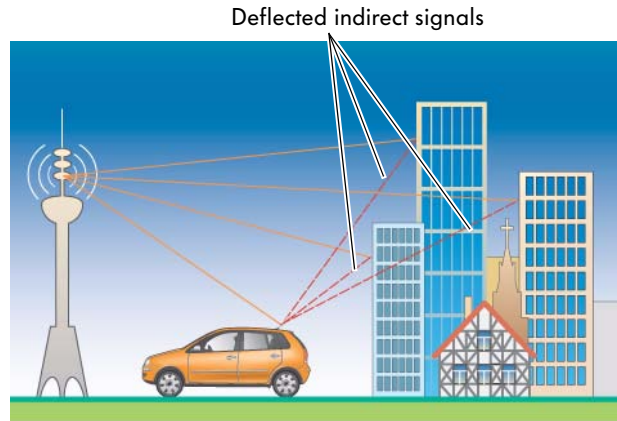

S342_003

The fluctuations of the reception level occur with VHF reception with relatively small changes of location. The vehicle shown in the diagram is equipped with two aerials at a distance of approx. 1 m from each other.

In the diagram, you can see that the front aerial has a very high receiving level and the rear one a very low one even though the distance between the two aerials is relatively small compared with the transmitter distance.

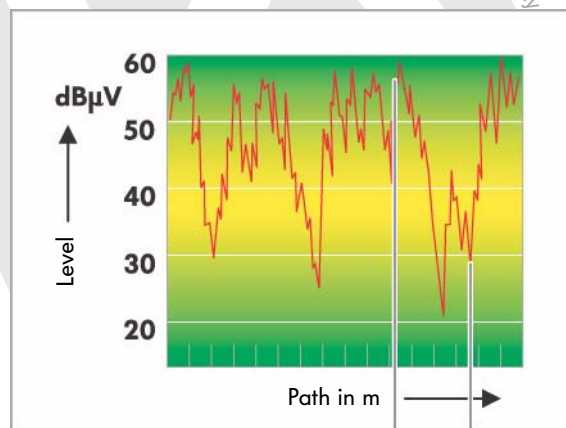

S342_005



Aerial properties

Reception properties of a standard FM aerial

The blue area indicates the direction-related reception sensitivity of the aerial. Here you can clearly see that the aerial is sensitive to signals from all directions. Direct and reflected signals are thus received with the same strength. This aerial configuration contributes to interference from multipath reception.

Overhead view of aerial

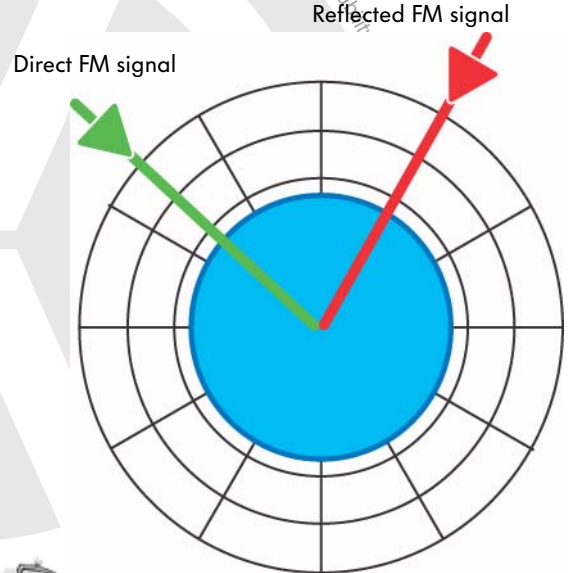

S342_006

Technical suppression of multipath interference

As multipath interference is unpleasant particularly in the higher audible frequency range, a technical solution to reduce interference is needed.

One possibility for reduction is the “highcut method”. However the disadvantage of this is that “cutting” the high frequencies has a negative effect on the sound in this range.

Interference-free audio signal

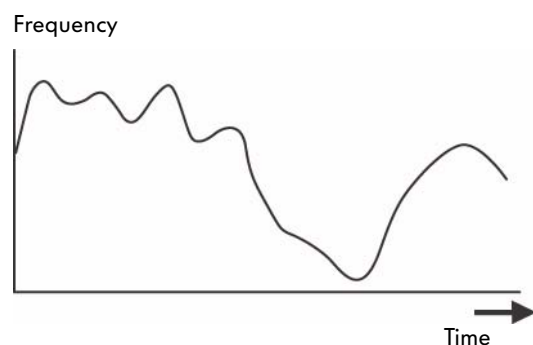

S342_007

The audio amplifier in the car radio amplifies all frequencies that can be heard by the human ear to a level appropriate to the human sensory range.

Receiving level

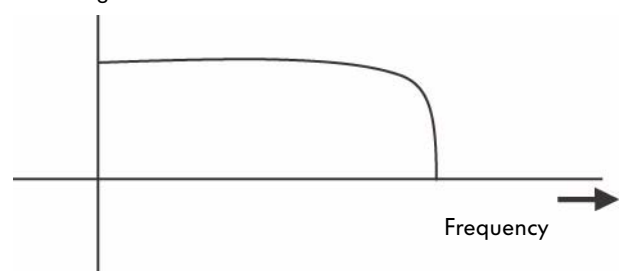

S342_008



Highcut

Interference from signal-changing disturbing pulses

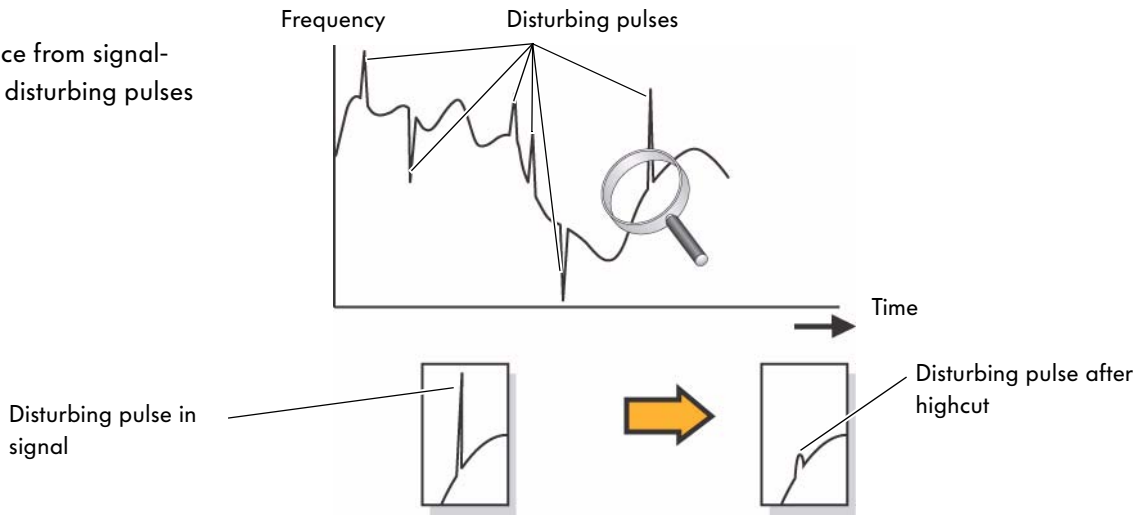

S342_009

If interference occurs in the upper frequency range due to multipath reception, it will be suppressed by the highcut function in the FM tuner of the car radio.

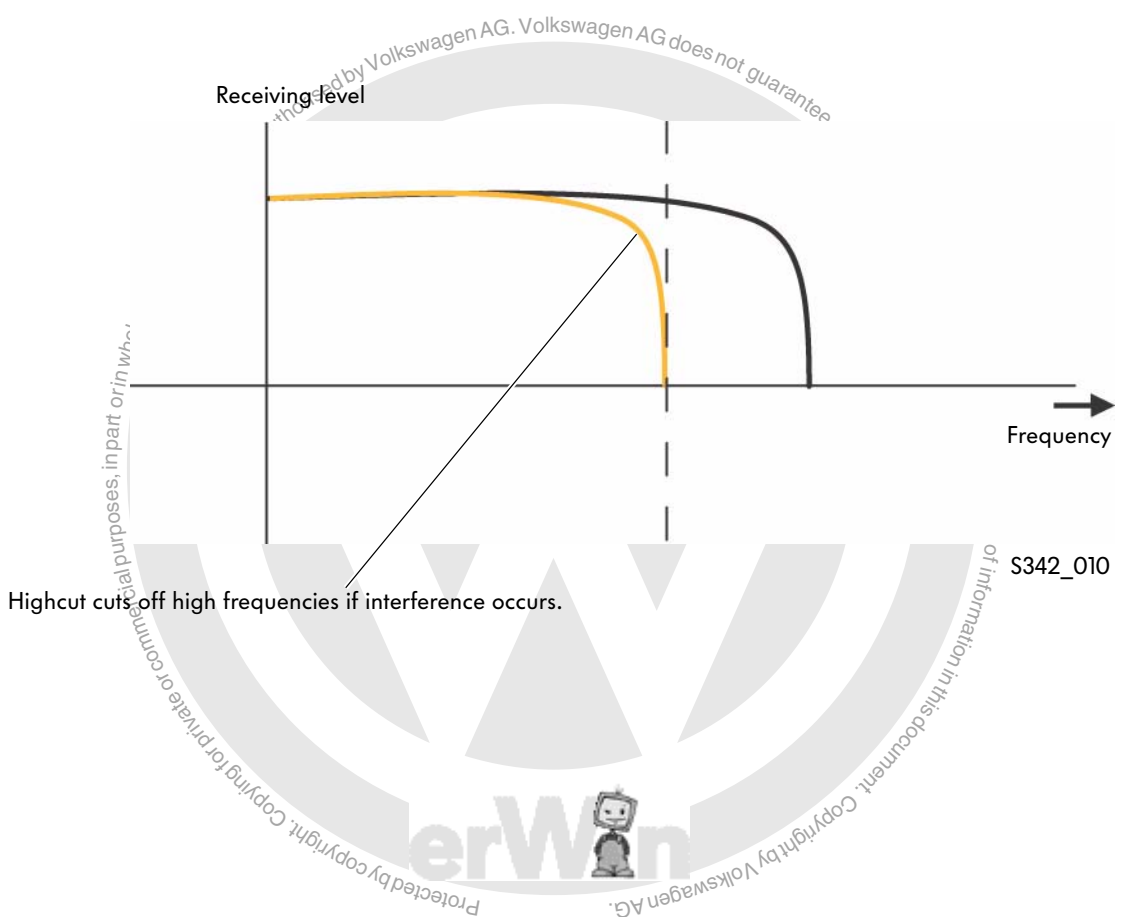

S342_010

Basics

Phase diversity

One better method of reducing interference is the phase diversity aerial principle. The phase diversity is also more technically complex than, for example, highcut as 2 tuners and 2 aerials are needed.

Phase diversity works with two different reception modes, the “interference-free signal” reception mode and the “interference signal” reception mode.

This reception type basically works in the same way as a directional aerial.

During operation, these aerials are continuously “turned” virtually in the direction of the signal source.

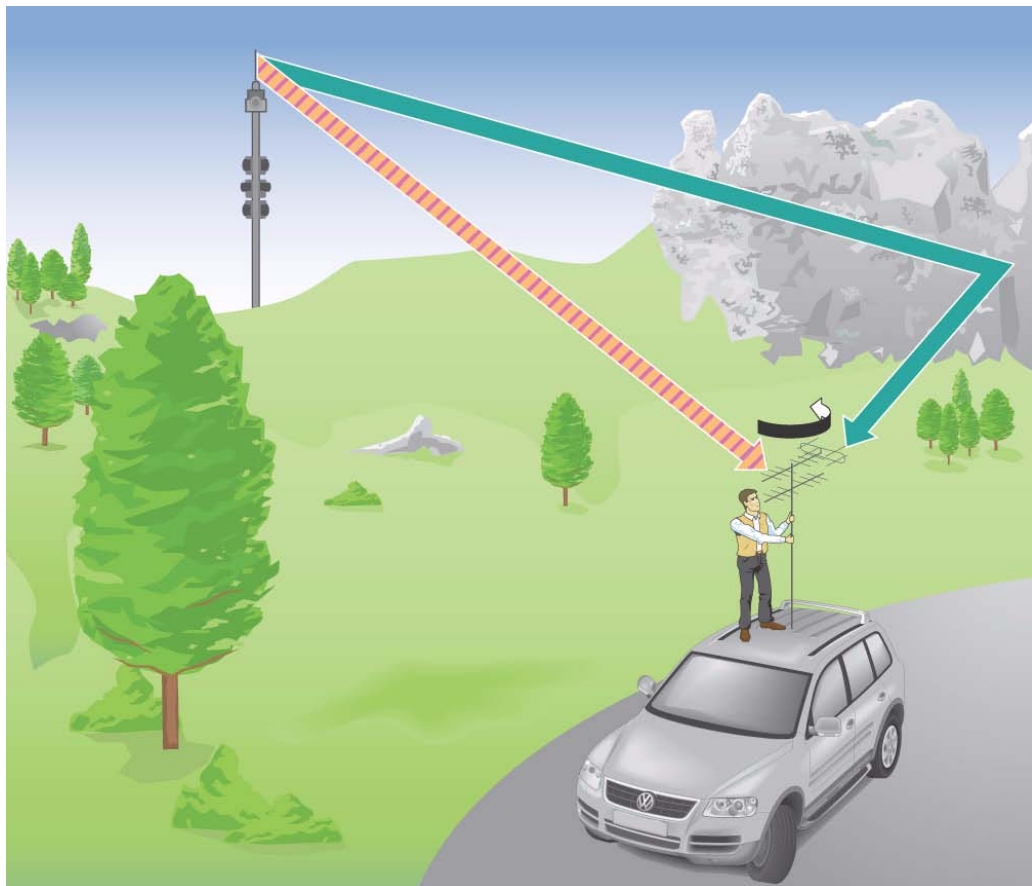

Turning the aerial is, of course, only simulated by the digital signal processing.

The aerial is not actually rotated. However, the effect is exactly the same. The aim is to provide the direct signal with as much aerial surface as possible and the reflected signal with as little as possible.

Receiving property of diversity aerial system with two FM aerials

The blue area indicates the direction-dependent reception sensitivity of the aerial system and the evaluation electronics.

You can clearly see here that the system for the direct signal is particularly sensitive while it is more insensitive to the reflected signal. Multipath interference is suppressed here to a great extent. Less highcut is therefore also used, which leads to a considerable sound improvement.

Furthermore the system is more sensitive in the direction of the direct signal. As a result, the reception is improved considerably and thus more stereo reception and less silent pauses are noticed.

Directional aerial

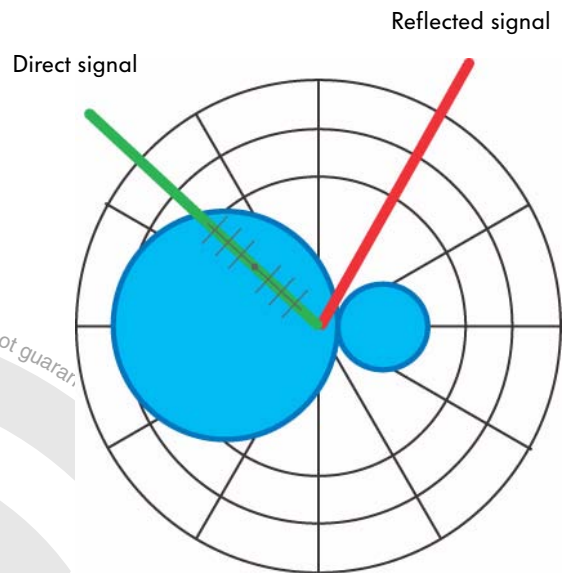

S342_012

Signal strength

The signal strength of a conventional single-tuner receiver is considerably lower compared with a two-tuner phase diversity receiver depending on the distance of the radio transmitter.

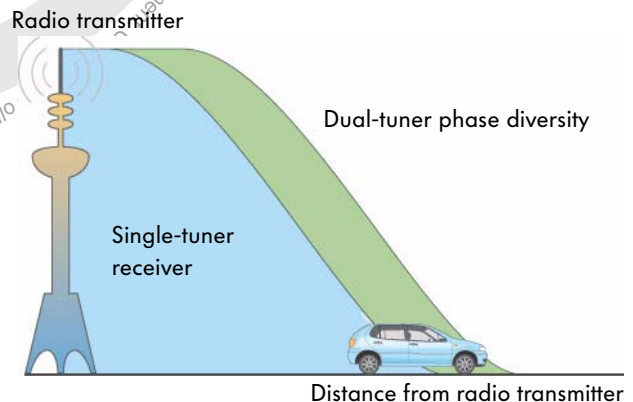

S342_013





“Interference-free signal” reception mode

In “interference-free” reception mode, the electronics in the radio constantly check which aerial receives the strongest signal and select the stronger one for the input signal.

The demodulator converts the HF aerial signals into inaudible signals and forwards them to the radio data system.

The second tuner constantly searches the whole frequency band for better reception frequencies for the selected station. If a better signal is found, this tuner switches to reception and the other switches to scanning mode in the background. This avoids the RDS-AF test pauses as experienced with single-tuner systems.

This is called the background mode (collect data).

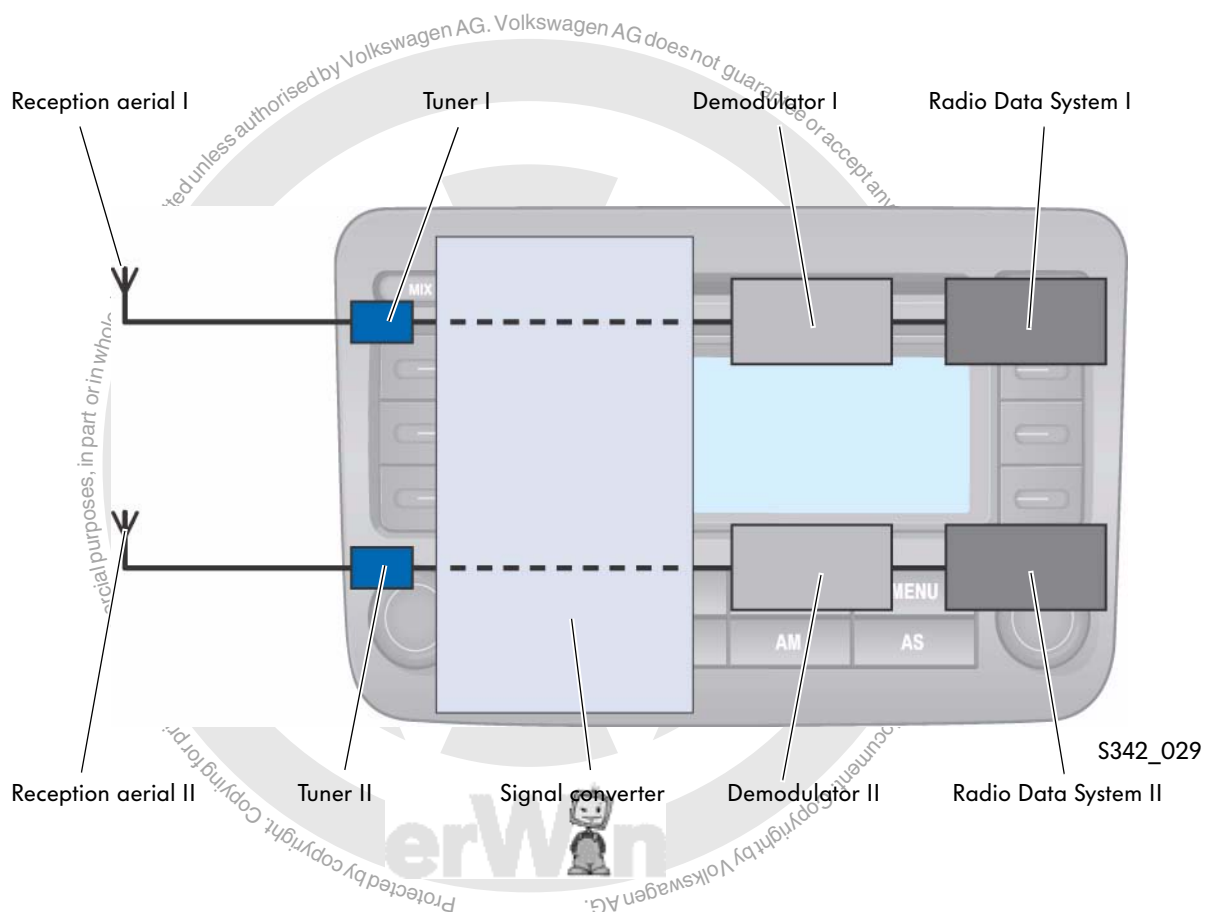



“Interference signal” reception mode

In “interference signal” reception mode, the signals from both aerials are digitised in an intermediate frequency analogue/digital converter and processed using an adaptive algorithm.

This process removes the interference signals by forming a new, directed aerial signal.

The aerial power is also improved by up to 3 dB.

The second demodulator and the second radio data system remain unused in the background in this mode as both aerials are required to receive the selected station.

This mode is called phase diversity.

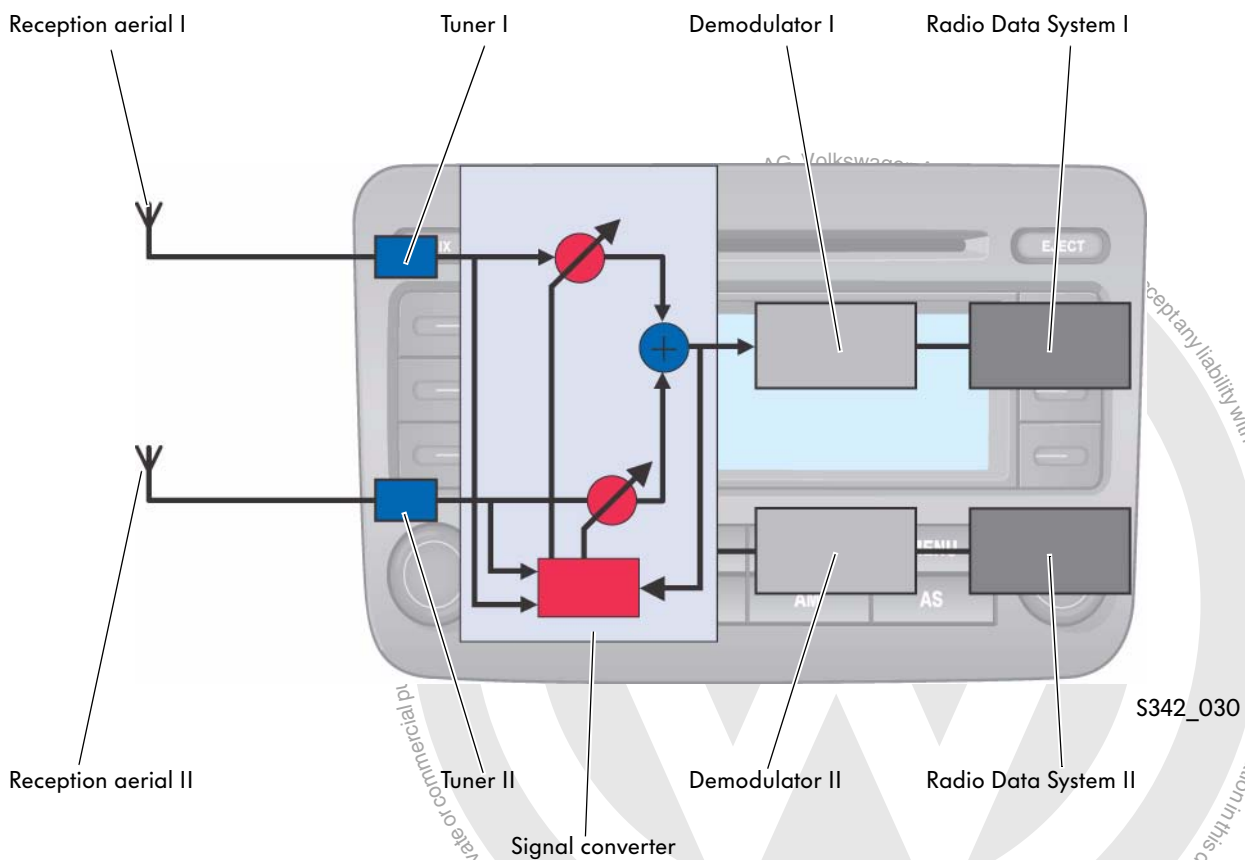



Audio CD (Audio Compact Disk)

Audio CDs, which started to become established among home users in 1982, are increasingly being used in cars and are becoming more popular than compact cassettes.

Audio CDs are optical mass storage media for the digital storage of music.

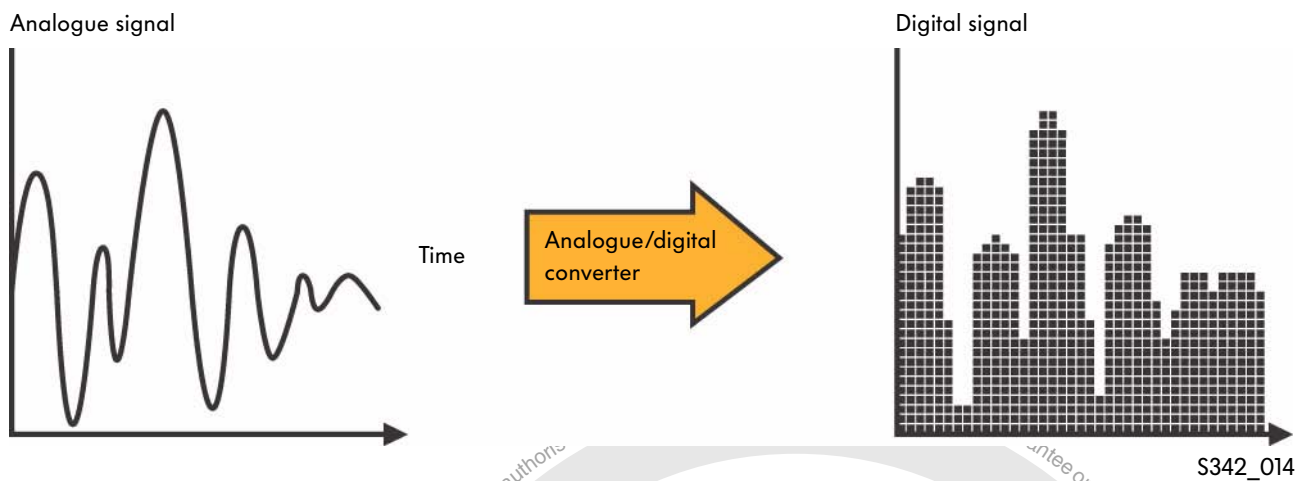

The analogue music signal is converted to a digital signal by an analogue/digital converter. The aim of digitalisation is to emulate the analogue signal digitally and without interference in as smaller steps as possible. The higher the resolution (e.g. 8 - 16 - 32 - 64 bit) of the A/D converter, the more authentic the sound result (emulation of the analogue signal).

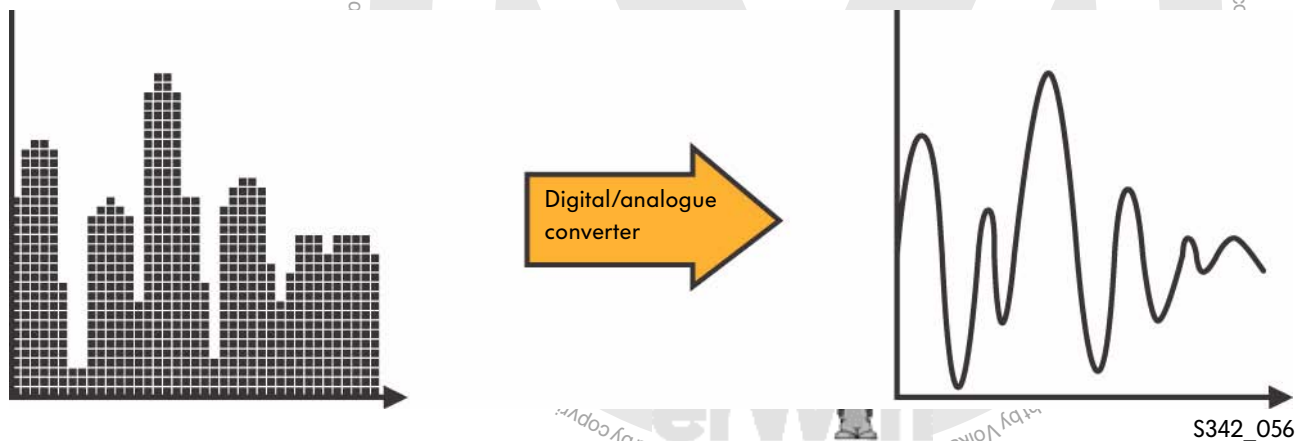

To obtain a suitable signal from the digital signals for playback via the speakers, an analogue signal needs to be formed again in the CD player using a D/A converter.



The CD mainly consists of a transparent carrier material (substrate), which is moulded by means of compression injection. The top side of this carrier contains the digital information in the form of microscopic pits and lands that are arranged in a single long, spiral track (around 5 km in total).

This surface containing information is covered with a thin aluminium film and sprayed with an acrylic layer. A label can then be applied or printed on. The information is scanned with a laser through the carrier layer without contact and thus free of wear.

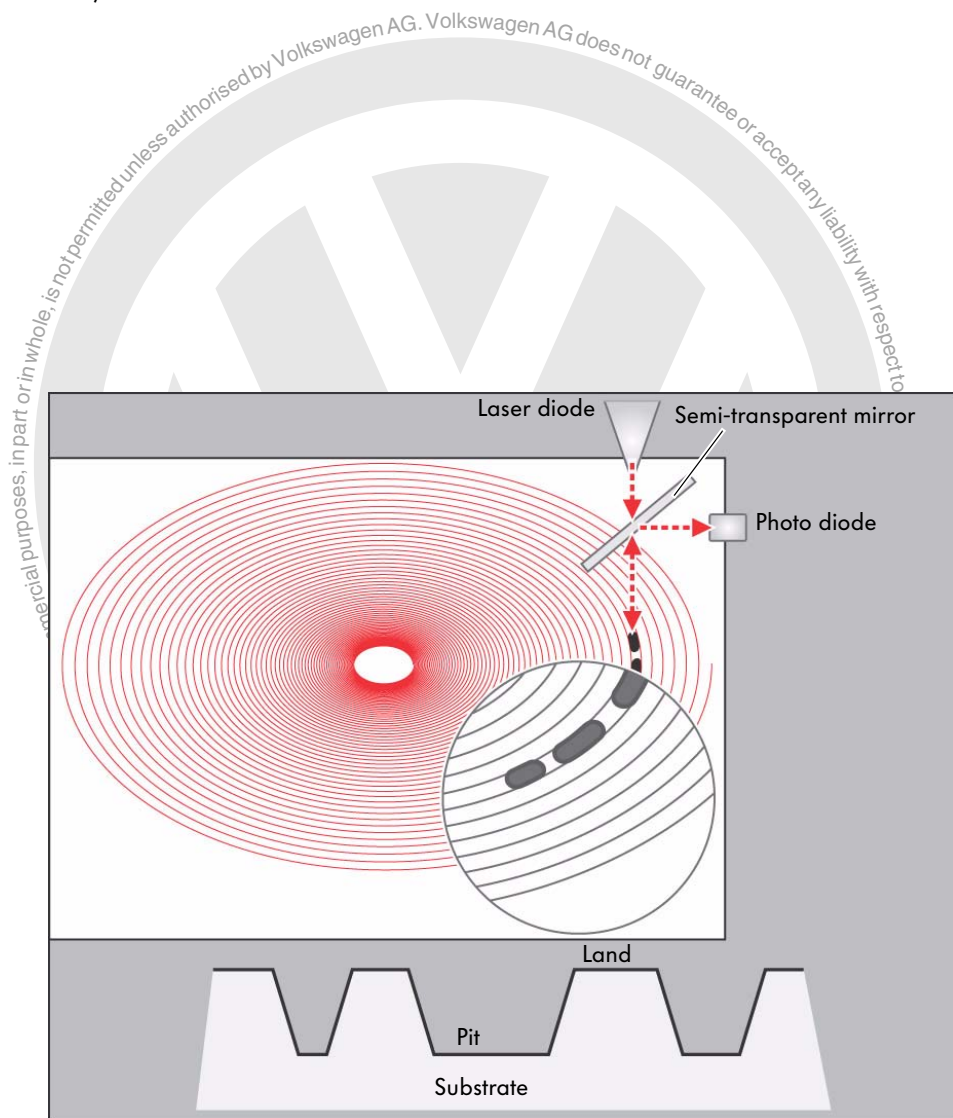

S342_015



Handling and care information for CDs and CD-ROMs

Only touch CDs by the sides.



S342_060

Avoid getting finger prints on the CD.



S342_061

If a CD becomes dirty, never wipe the CD with circular motions. Instead wipe with a soft lint-free cloth from the inside to the outside.

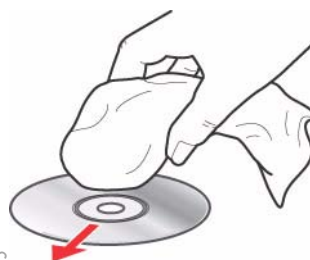

S342_062

Also handle CDs carefully both from the underside and from the top. Do not write on the CD and do not affix labels.



S342_063

All CDs should be handled carefully and always be stored in a protective case. Also keep CDs away from heat and direct sunlight.

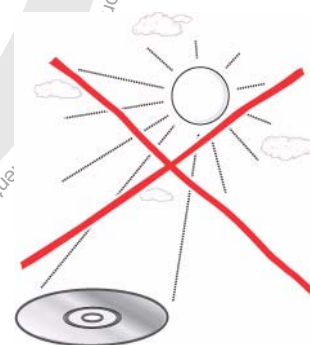

S342_064

Moving Picture Experts Group (MPEG) MP3

MP3 is a file format for audio compression. Like other formats, MP3 is based on the fact that human perception is limited. The number of sounds that people perceive is reduced, for example, due to their frequency or volume. As this process involves losses, the original output signal cannot be reproduced completely.

The losses depend greatly on the data rate. At around 128 kBit/s, the differences from the original are hardly noticeable if music with a low dynamic scope is involved (pop music, synthesizer, techno). For example, with guitar and violin music, you will soon notice annoying differences to the original at 128 kBit/s, average data rates of 192 kBit/s or higher are recommended for this style of music.

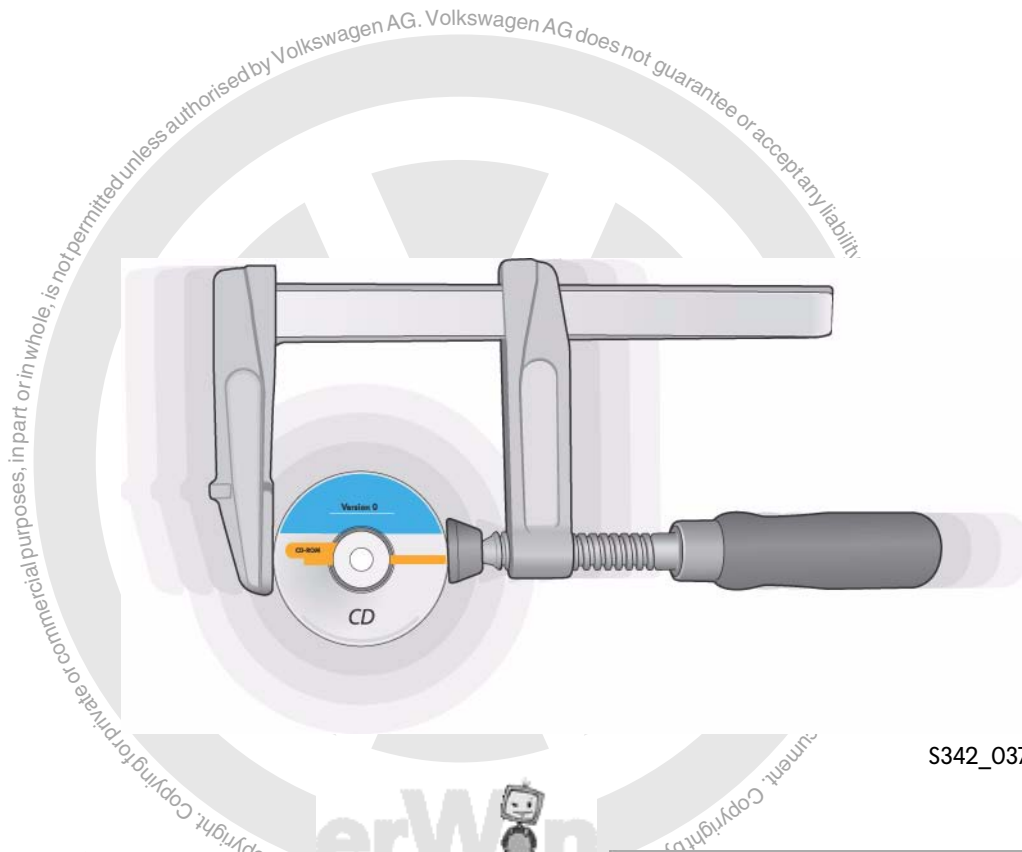

S342_037

Non-audible frequencies — the range perceivable by adults is from 20 Hz to 18 kHz — are cut off in the data.

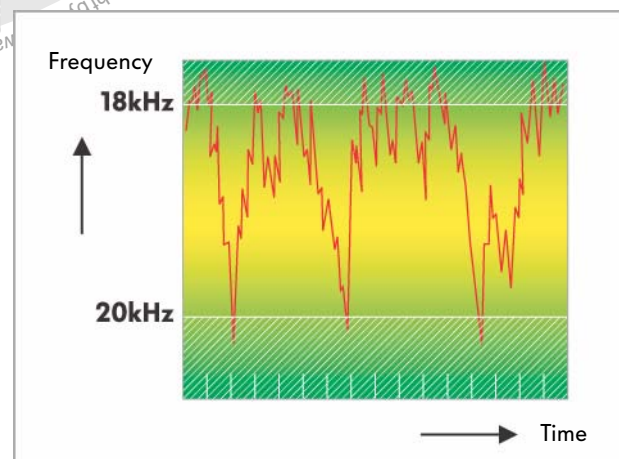

S342_058





Digital Audio Broadcasting (DAB)

The Digital Audio Broadcasting system (DAB) differs considerably from previous analogue data transfer systems. In DAB, the receiver does not only receive an audio signal (music, language), but also additional data signals (services) with information on travel, schedule, music, weather, etc.

If the radio is equipped with a suitable display, graphics, for example, maps or animations, can also be displayed.

The DAB frequency range (474 MHz to 1468 MHz) is divided up into several channels each with a bandwidth of 1.536 MHz. The basic signals for audio and service data are digitised in the transmitter, compressed (MPEG) encoded separately and chopped up into time sections. Then all basic signals are combined in a frequency mixer and sent to the respective channel in digital form.

That is the content of a station in the simplest form (e.g. NDR 2).

That means

- Separation into programmes
- Separation according to audio tracks and service
- Reassemble signal in order
- Decode signal
- D/A conversion

Regions with DAB in Germany



S342_031



Due to the data reduction, it is generally the case that several stations find space in the bandwidth of a channel with their respective audio tracks and services.

All of these programs combined in a channel are called an ensemble (e.g. North I). In the receiver, the DAB radio, the signals are processed in reverse order.

The DAB transmission accesses the conventional terrestrial transmission systems. Due to the low susceptibility to interference of digital signals, the transmitter can work with a radiated power of approx. 1 kW. A typical VHF transmitter has a transmission power of 10 to 100 kW.

DAB ensemble

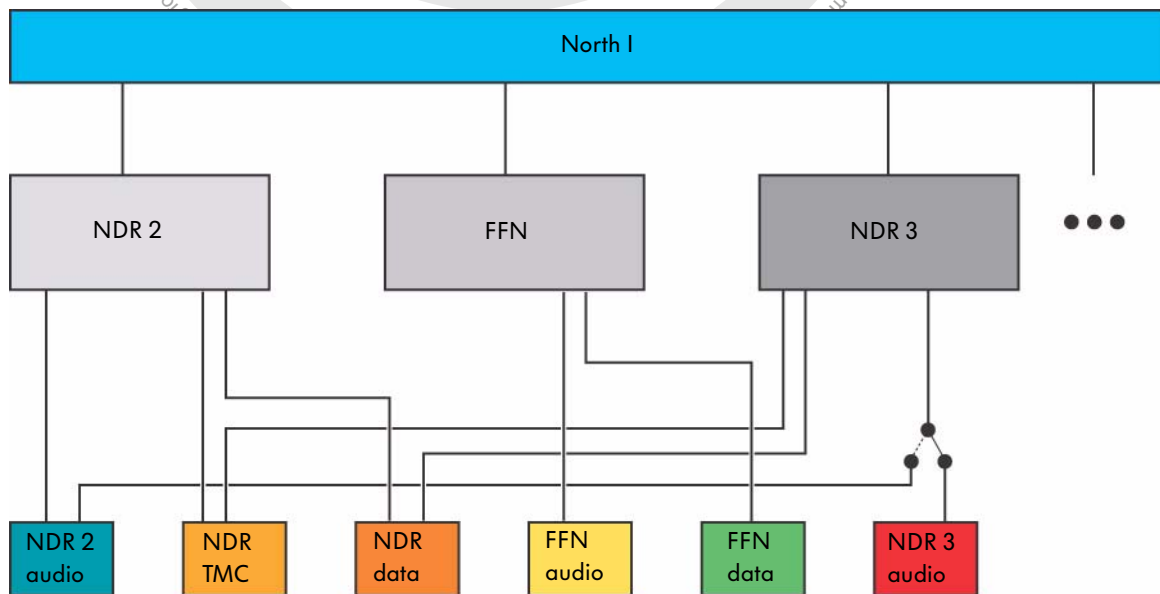

S342_057

Radio Systems

R 100 radio

The R 100 radio is available for the Volkswagen Golf 2004, Touran and in other models for bulk customers, e.g. fleet operators.

This radio unit has the following functions:

Single-tuner

- Two output stage with 20 Watt output, 2 speaker channels can be connected
- RDS FM/AM Europa radio (VHF/MW)
- Control for an external 6-CD changer
- Mute mode for telephone hands-free system
- Speed-dependant volume control (GALA)
- Self-diagnosis incl. loudspeaker diagnosis
- Transport mode (reduction of the current requirement during transport and rest times)



Station buttons 1-3

Pressing the station buttons calls up the stored stations.

You can store stations manually (once a station has been tuned, hold down the station button until you hear a signal) or automatically (hold down the AS button until STORE appears in the display).

On/off switch

Pressing the tuning knob switches the radio on and off.

The last station tuned and last volume level set will be selected.

TP button

When the TP option is switched on, only stations that broadcast regular traffic reports will be offered (traffic program stations) during automatic station searches.

If a traffic program station is tuned, an incoming traffic report will be played in the current radio mode.

CD button

Select CD changer mode

Display

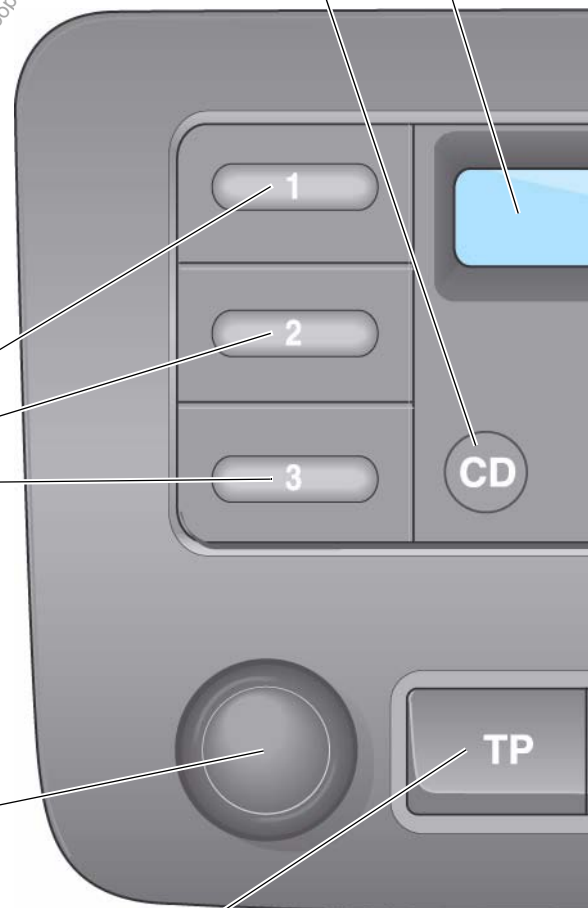



Please follow the respective operating manual when using the radio.

BAL button

Press this button to open the menu for setting the balance.
Turn the tuner knob to change the volume balance on the left and right.

Sound settings

Pressing this button opens the menu for adjusting the bass (display: BASS).
Press it again to open the menu for adjusting the treble (display: TREB).
Turn the tuner knob to the desired tone level.

Station search buttons

Station buttons 4-6

AS button (auto store)

If you press the AS button, the six stations with the greatest field strength are stored automatically and spread across the station buttons according to their field strength.

Tuning knob

- For manual station tuning
- For sound settings (BASS, TREBLE), BALANCE and GALA
- For the SCAN function

FM

FM button

Press to select the VHF (frequency modulation) frequency range.

AM

AM button

Press to select the MW (amplitude modulation) frequency range.

AS

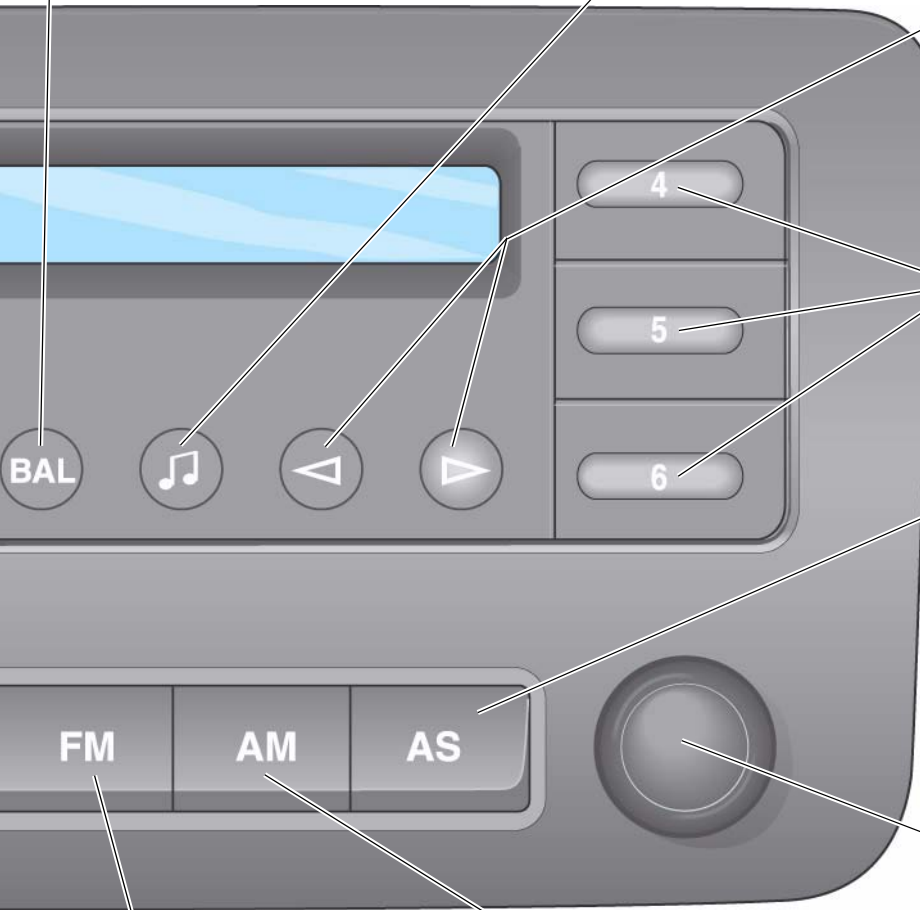

AG does not guarantee or accept any liability with respect to the correctness of information in this document. Copyright Volkswagen AG.

S342_016

Radio Systems

Functional diagram for R 100 radio in Volkswagen Golf/Touran

Legend

- A Battery
- R Radio
- R11 Aerial
- R20 Front left treble loudspeaker
- R21 Front left bass loudspeaker
- R22 Front right treble loudspeaker
- R23 Front right bass loudspeaker
- R41 CD changer
- R108 Left aerial module
- S Fuse

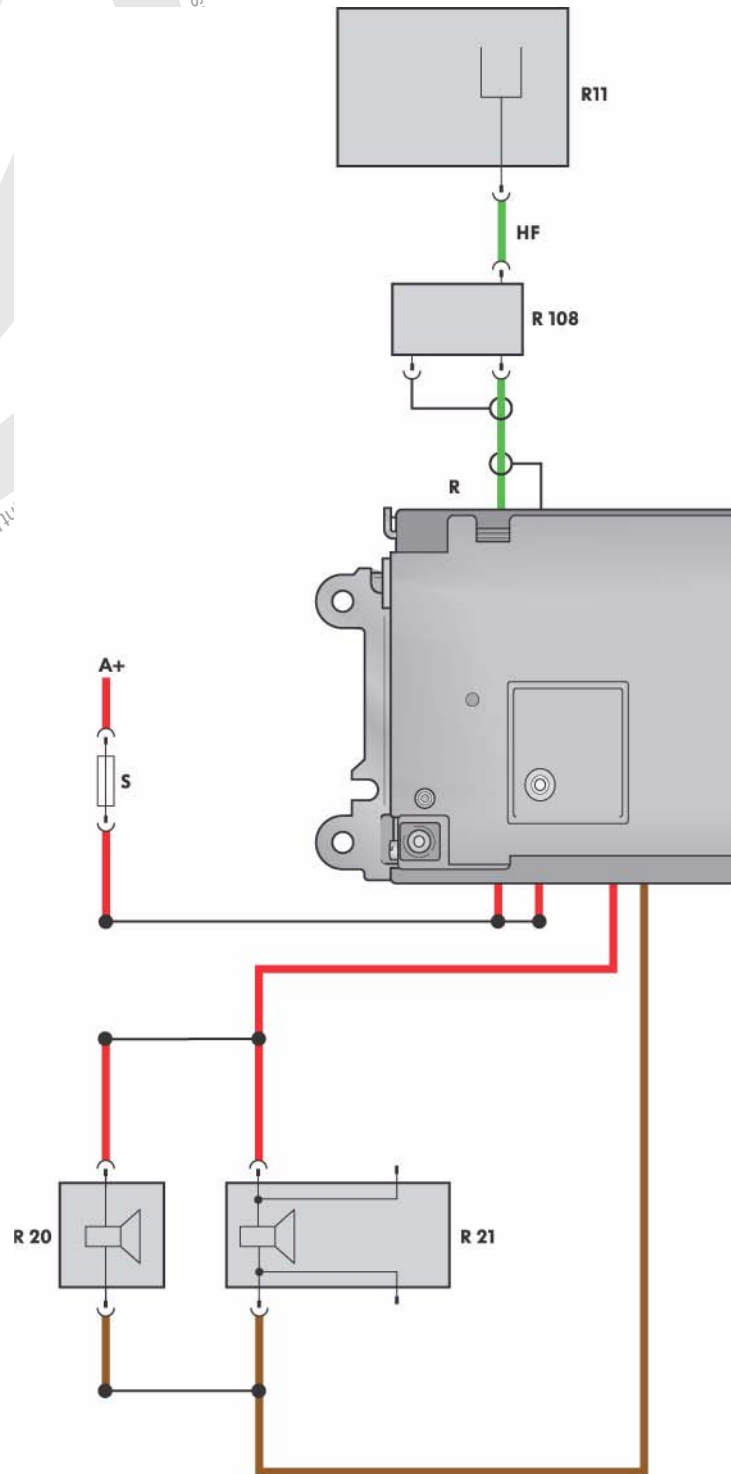

- Input signal
- Output signal
- Voltage supply (plus)
- Earth (minus)
- CAN data bus line

id unless authorised by Volkswagen AG. Volkswagen AG does not guarantee or accept any liability with respect to the correctness of information in this document. Copyright by Volkswagen AG.

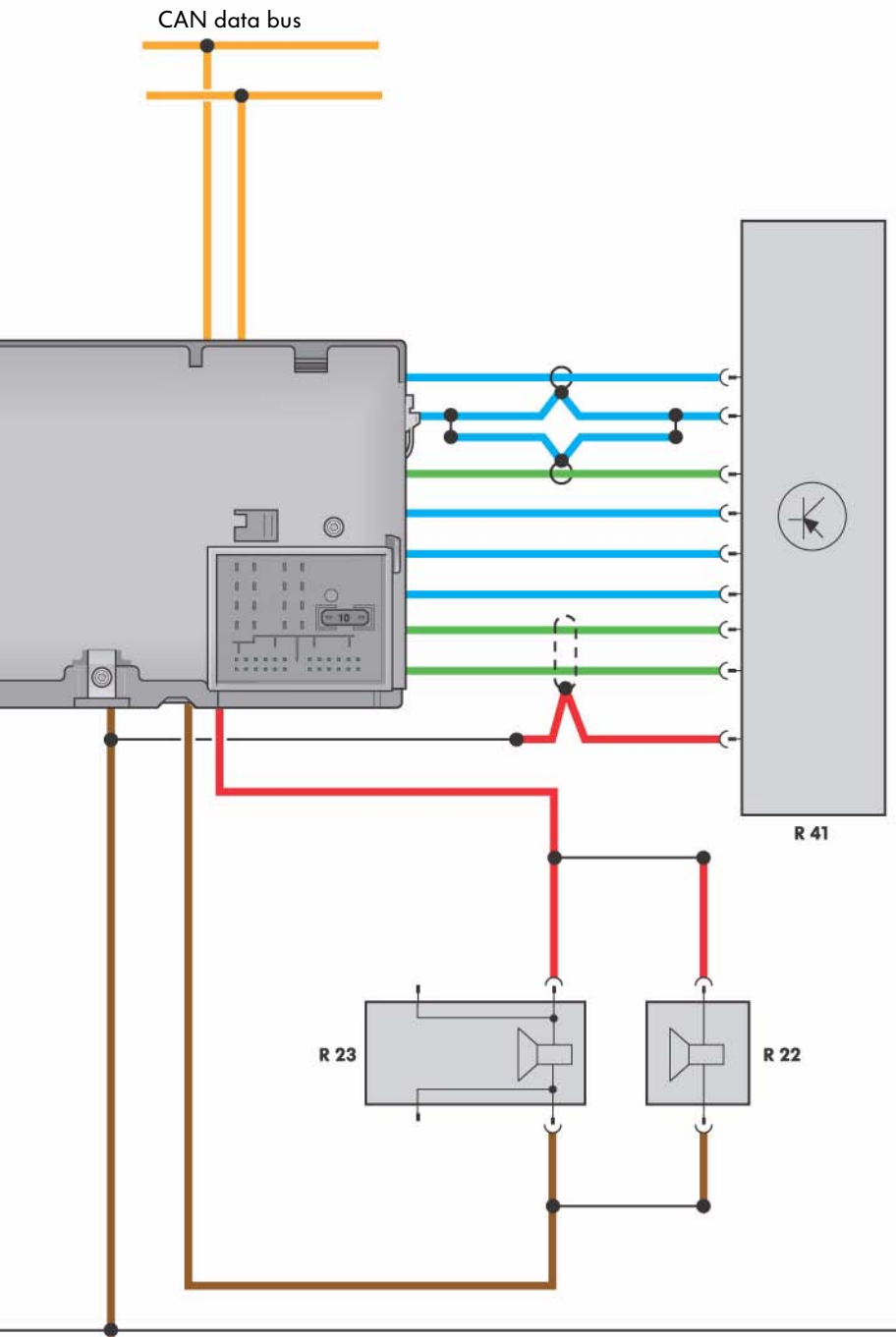

S342_022

Radio Systems

RCD 200 radio

- Single-tuner
- Four output stages with 20 Watt output, 2 or 4 speaker channels can be connected
- RDS FM/AM Europa radio (VHF/MW)
- Integrated single CD drive
- Control for an external 6-CD changer
- Convenience code
- Mute mode for telephone hands-free system
- Speed-dependant volume control (GALA)
- Self-diagnosis incl. loudspeaker diagnosis
- Transport mode (reduction of the current requirement during transport and rest times)

Balance/fader button

Pressing the B/F button opens the menu for setting the balance (display: BAL). Press it again to open the menu for adjusting the volume distribution between the front and rear (fader, display: FAD). Turn the tuner knob to the desired setting.



Station buttons 1-3

Pressing the station buttons calls up the stored stations.

You can store stations manually (once a station has been tuned, hold down the station button until you hear a signal) or automatically (hold down the AS button until STORE appears in the display).

AS button (auto store)

If you press the AS button, the six stations with the greatest field strength are stored automatically and spread across the station buttons according to their field strength.

On/off switch

Pressing the tuning knob switches the radio on and off. The last station tuned and last volume level set will be selected.

FM button

Press to select the VHF (frequency modulation) frequency range.

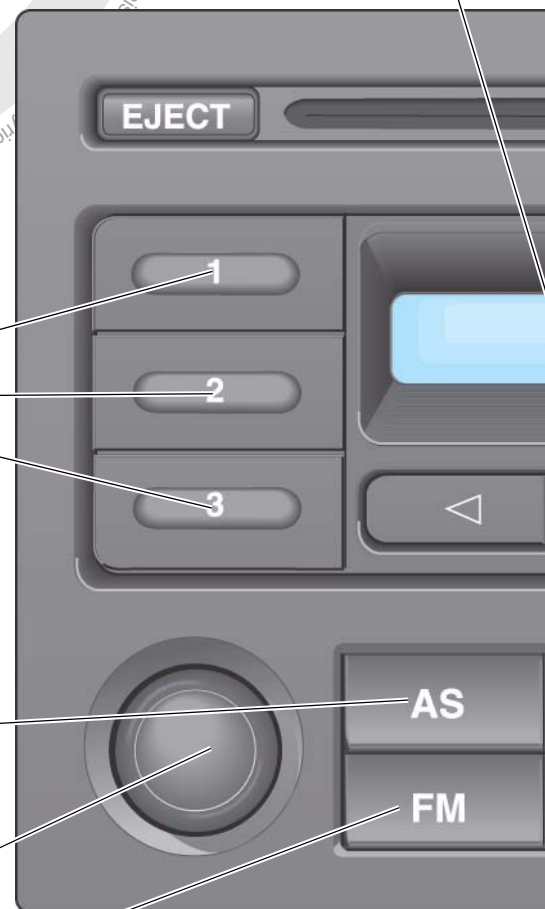

The output stages for the rear speakers are only active if speakers are actually connected. The fader functions will only become active when they are connected.

TRE tone button

Pressing the TRE button opens the menu for setting the treble (display: TRE).

Turn the tuner knob to the desired tone level.

BAS tone button

Pressing the BAS button opens the menu for setting the bass (display: BASS).

Turn the tuner knob to the desired tone level.

Mix button

The tracks on the current CD will be played in a random order.

Station buttons 4-6

Tuning knob

- For manual station tuning
- For sound settings (BASS, TREBLE), BALANCE, and GALA
- For the SCAN function
- For track selection in CD mode

TP button

When the TP option is switched on, only the stations that broadcast regular traffic reports will be offered (traffic program stations) during automatic station searches.

If a traffic program station is tuned, an incoming traffic report will be played in the current radio mode.

CD button

Press this button to switch to CD mode or CD changer mode.

AM button

Press to select the MW (amplitude modulation) frequency range.

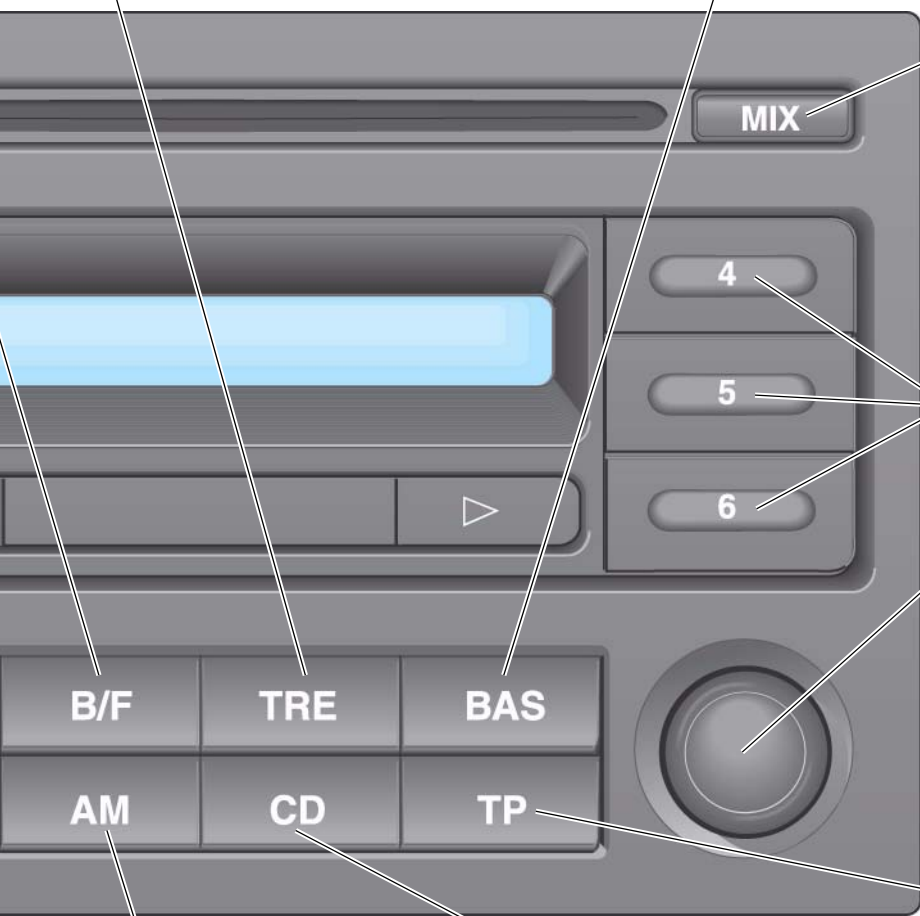

S342_017



Radio Systems

Functional diagram for RCD 200 radio in Volkswagen Fox/Polo 2006

Legend

- A Battery
- R Radio
- R11 Aerial
- R15 Rear left bass loudspeaker
(Polo: treble and bass loudspeakers)
(Fox: wide band loudspeaker)
- R17 Rear right bass loudspeaker
(Polo: treble and bass loudspeakers)
(Fox: wide band loudspeaker)
- R21 Front left bass loudspeaker
(treble and bass loudspeaker)
- R23 Front right bass loudspeaker
(treble and bass loudspeakers)
- R24 Aerial amplifier
- R41 CD changer
- S Fuse

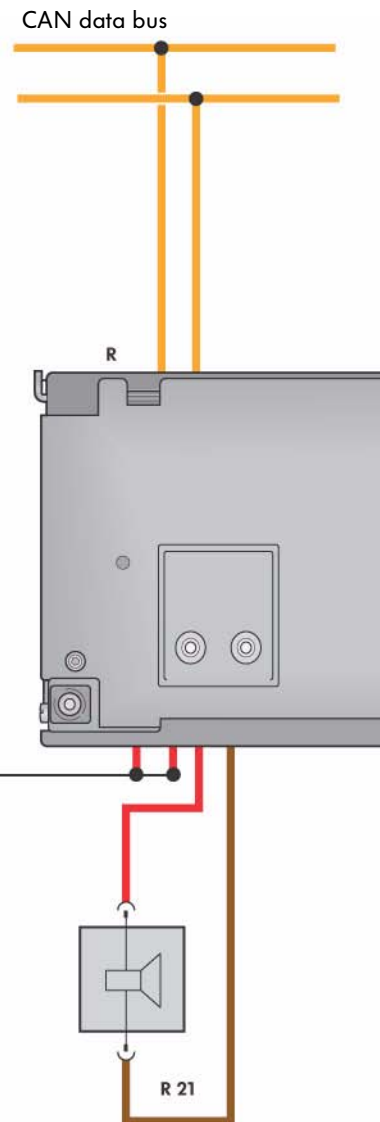

- Input signal
- Output signal
- Voltage supply (plus)
- Earth (minus)
- CAN data bus line

Unless authorised by Volkswagen AG, Volkswagen AG does not guarantee or accept...

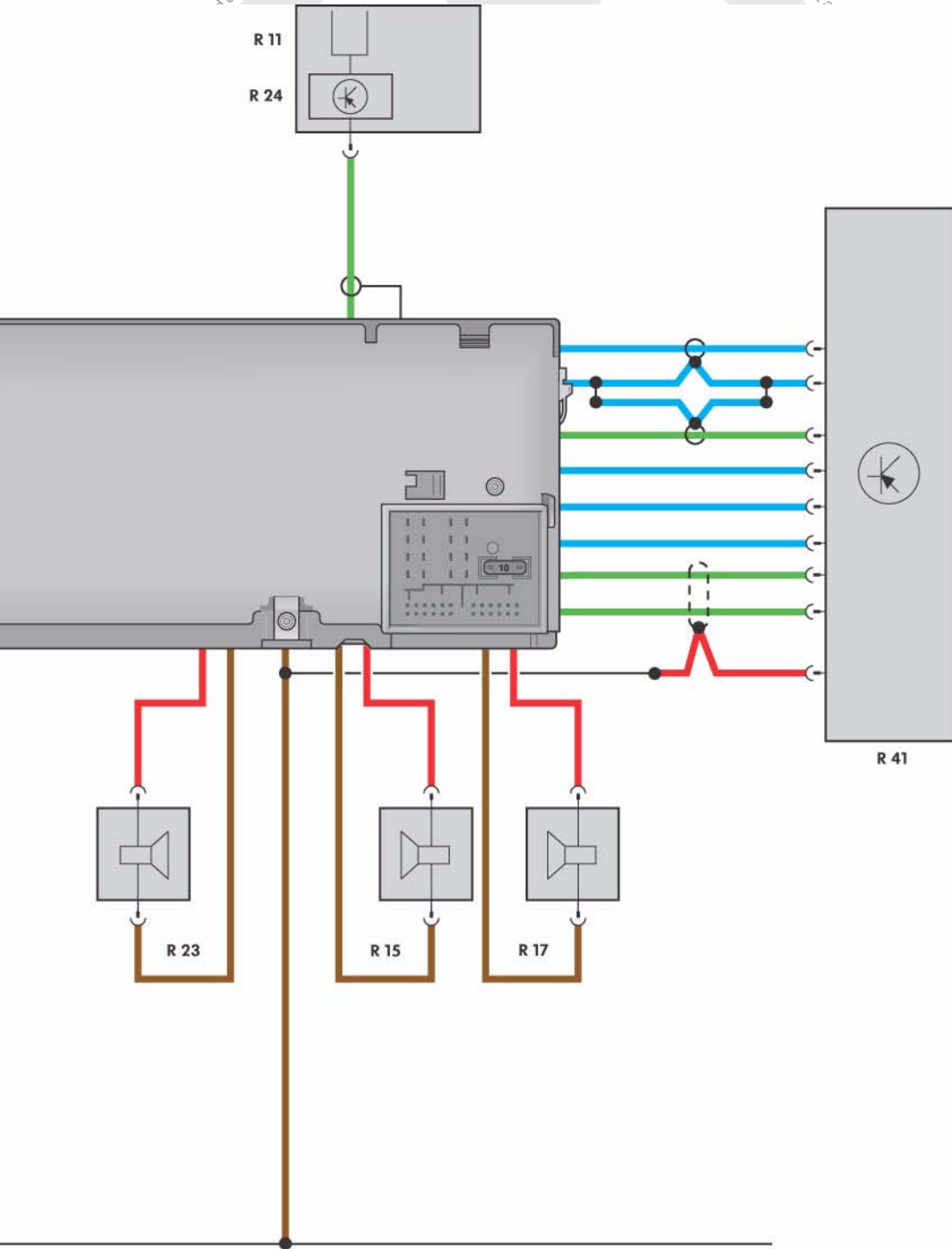

S342_023

Radio Systems

RCD 300 radio

The RCD 300 radio is available as the standard radio system for private customers.

It has the following functions:

- FM dual-tuner diversity
- Four output stages with 20 Watt output, 2 or 4 speaker channels can be connected
- RDS FM/AM Europa radio (VHF/MW)
- Stored stations with RDS name shown in display
- Control via multifunction steering wheel (MFW) and multifunction display (MFD)
- Integrated single CD drive
- Control for an external 6-CD changer
- Convenience code
- Mute mode for telephone hands-free system
- Speed-dependant volume control (GALA)
- Self-diagnosis incl. loudspeaker diagnosis
- Transport mode
- Driving school version (optional)

Multifunction buttons

The functions of the multifunction buttons depend on the respective operating mode. The current assignment of the multifunction buttons is shown in the display.

CD button

Press this button to switch to CD or CD changer mode.

On/off switch

Pressing the tuning knob switches the radio on and off. The last station tuned and last volume level set will be selected.

Mix button

The tracks on the current CD will be played in a random order.

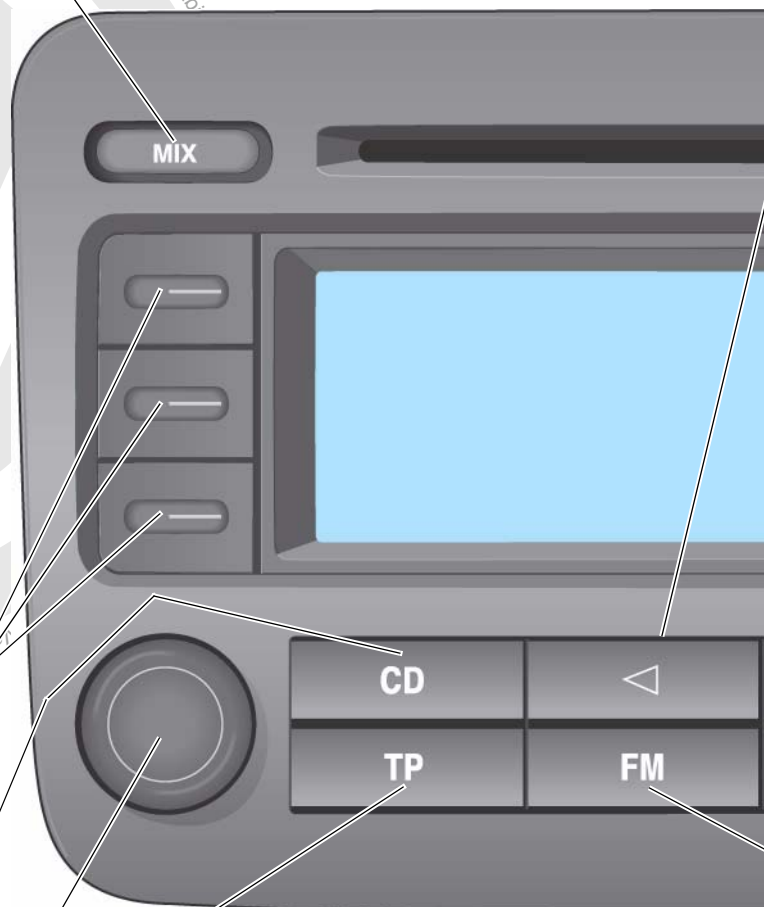

TP button

When the TP option is switched on, only the stations that broadcast regular traffic reports will be offered (traffic program stations) during automatic station searches. If a traffic program station is tuned, an incoming traffic report will be played in the current radio mode.

Station search buttons

Radio:

Press briefly to search for stations automatically.

CD mode:

Press briefly to select the tracks on the current CD;
hold down to listen to a CD track in rewind/fast forward mode.

Menu functions:

Pressing switches the menu functions on and off.

Menu button for sound settings and setup

SOUND:

The menus for setting the tone (TREBLE, BASS) and volume distribution (BALANCE, FADER) are called up with the multifunction buttons.

You make the settings with the tuning knob.

SETUP:

The SETUP menu is called up from the SOUND menu. The GALA, ON-VOL and RDS-REG settings are made with the tuning knob and the search buttons.

Multifunction buttons

Tuning knob

- For manual station tuning
- For the SCAN function
- For track selection in CD mode

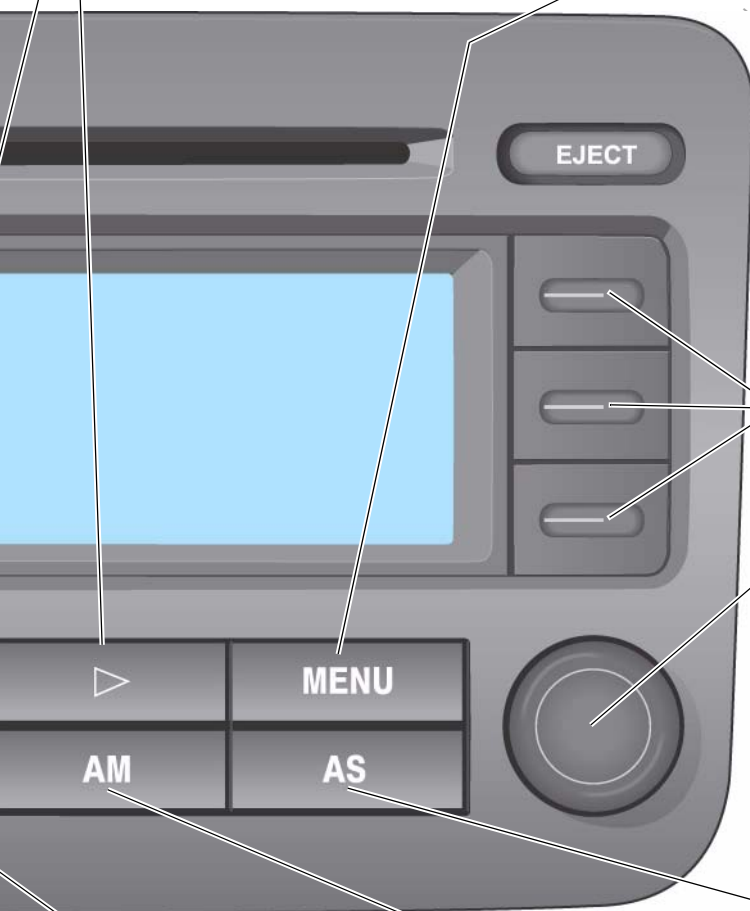

S342_018

FM button

Press to select the VHF (frequency modulation) frequency range.

AM button

Press to select the MW (amplitude modulation) frequency range.

AS button (auto store)

If you press the AS button, the six stations with the greatest field strength are tuned automatically and stored in the second memory level (AM 2/FM 2) according to their field strength.



Protected by copyright. Copyright by Volkswagen AG. Volkswagen AG does not guarantee or accept any liability in respect to the correctness of information in this document.

Radio Systems

Functional diagram for radio RCD 300 in Volkswagen Touran

Legend

A	Battery
R	Radio
R11	Aerial (AM/FM)
R14	Rear left treble loudspeaker
R15	Rear left bass loudspeaker
R16	Rear right treble loudspeaker
R17	Rear right bass loudspeaker
R20	Front left treble loudspeaker
R21	Front left bass loudspeaker
R22	Front right treble loudspeaker
R23	Front right bass loudspeaker
R41	CD changer
R93	Radio aerial 2 (FM)
R108	Left aerial module
R109	Right aerial module
S	Fuse

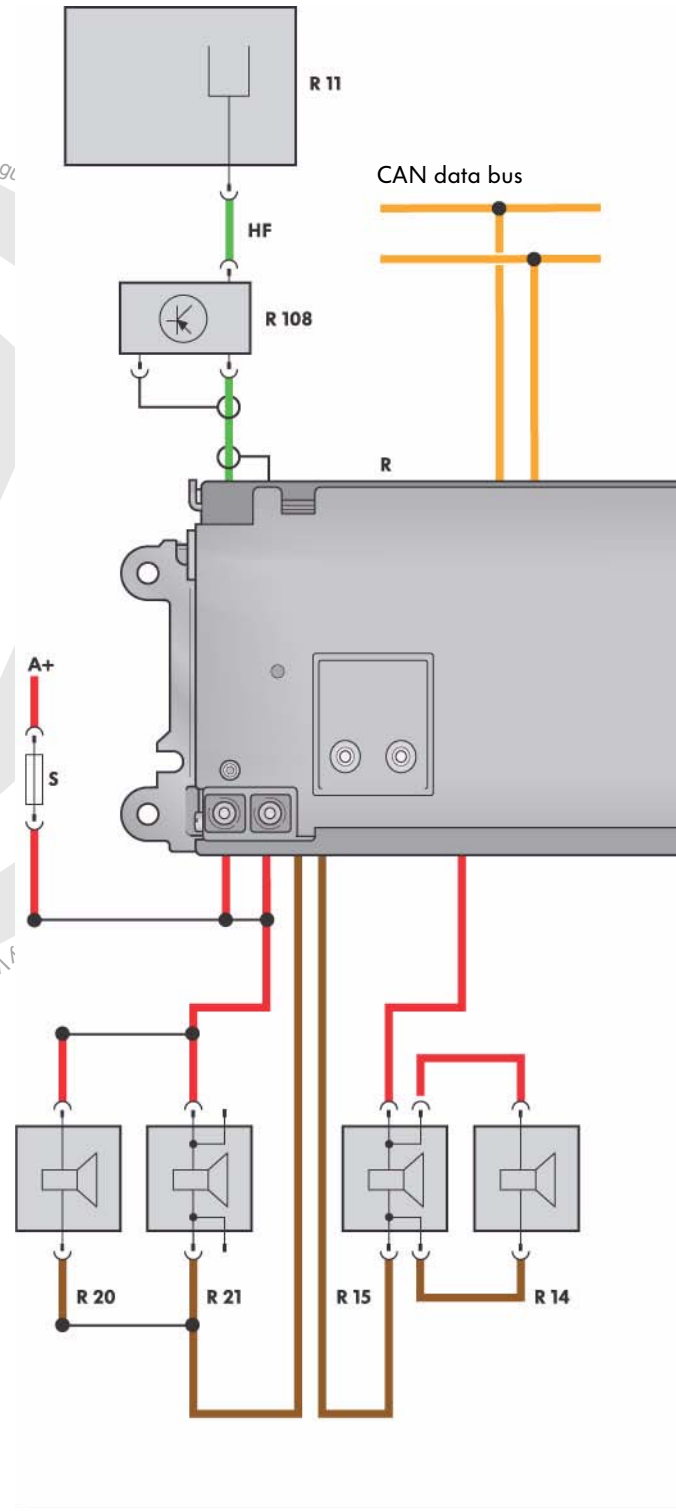

█	Input signal
█	Output signal
█	Voltage supply (plus)
█	Earth (minus)
█	CAN data bus line

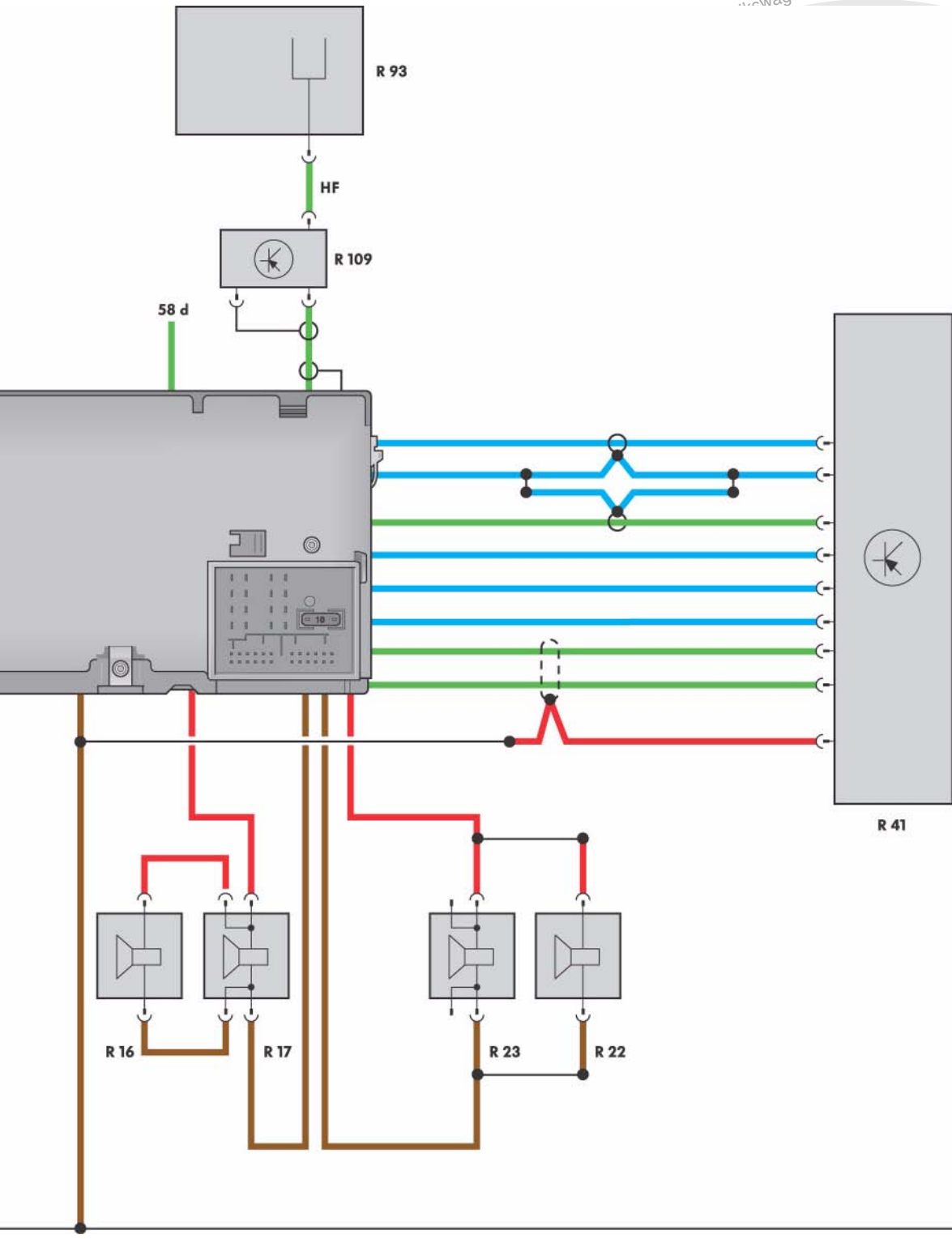

Volkswagen AG. Volkswagen AG does not guarantee or accept any liability with respect to the accuracy of the information in this document. Copyright by Volkswagen AG.



S342_024

Radio Systems

RCD 500 radio

The top of the range radio is the RCD 500 with the following functions:

- FM dual-tuner diversity
- Four output stages with 20 Watt output, 4 speaker channels connected
- RDS FM/AM Europa radio (VHF/MW)
- Stored stations with RDS name shown in display
- Control via MFW and MFD
- Integrated 6-CD changer
- Control for an external 6-CD changer
- Mute mode for telephone hands-free system
- Speed-dependant volume control (GALA)
- Traffic Information Message (TIM)
- Convenience code
- Self-diagnosis incl. loudspeaker diagnosis
- Transport mode
- Optional external sound amplifier can be connected (output stage reduction by 14 dB)

Mix button (random playback)

The tracks on the current CD will be played in a random order.



Multifunction buttons

Traffic Information Messages (TIM)

The TIM button allows you playback recorded traffic reports. After entering up to two different TIM times in the SETUP menu, you will be able to record traffic reports at a specific time even when the radio is turned off.

On/off switch

Pressing the tuning knob switches the radio on and off. The last station tuned and last volume level set will be selected.

TP button

When the TP option is switched on, only the stations that broadcast regular traffic reports will be offered (traffic program stations) during automatic station searches. If a traffic program station is tuned, an incoming traffic report will be played in the current radio mode.

Station search buttons

Radio:

Press briefly to search for stations automatically.

CD mode:

Press briefly to select the tracks on the current CD; hold down to listen to a CD track in rewind/fast forward mode.

Menu functions:

Pressing switches the menu functions on and off.

Menu button for sound settings and setup

SOUND:

The menus for setting the tone (TREBLE, BASS) and volume distribution (BALANCE, FADER) are called up with the multifunction buttons.

You make the settings with the tuning knob.

SETUP:

The SETUP menu is called up from the SOUND menu.

The GALA, ON-VOL and RDS-REG settings are made with the tuning knob and the search buttons.

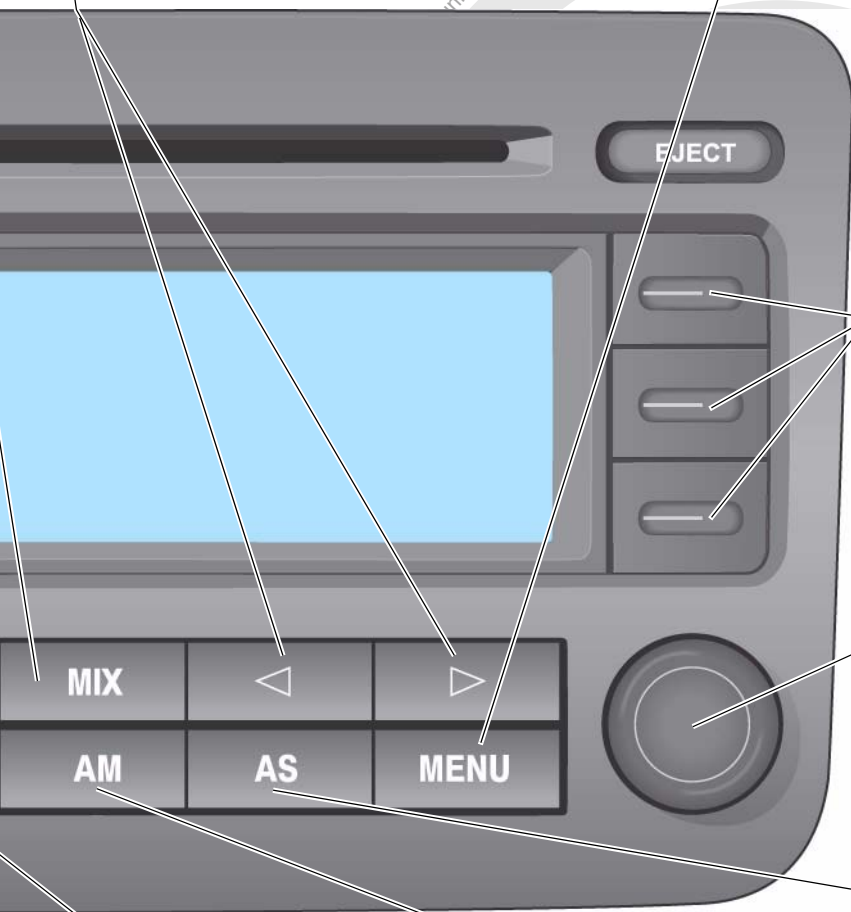

Multifunction buttons

The functions of the multifunction buttons depend on the respective operating mode.

The current assignment of the multifunction buttons is shown in the display.

Tuning knob

- For manual station tuning
- For the SCAN function
- For track selection in CD mode

AS button (auto store)

If you press the AS button, the six stations with the greatest field strength are tuned automatically and stored in the second memory level (AM 2/FM 2) according to their field strength.

S342_019

FM button

Press to select the VHF (frequency modulation) frequency range.

AM button

Press to select the MW (amplitude modulation) frequency range.



Radio Systems

Functional diagram for radio RCD 500 in Volkswagen Golf

Legend

A	Battery
J519	Onboard supply control unit
R	Radio
R11	Aerial
R14	Rear left treble loudspeaker
R15	Rear left bass loudspeaker
R16	Rear right treble loudspeaker
R17	Rear right bass loudspeaker
R20	Front left treble loudspeaker
R21	Front left bass loudspeaker
R22	Front right treble loudspeaker
R23	Front right bass loudspeaker
R41	CD changer
R93	Radio aerial 2
R108	Left aerial module
R109	Right aerial module
R177	Amplitude modulation frequency filter (AM)
R178	Frequency modulation frequency filter (FM) in the negative wire
R179	Frequency modulation frequency filter (FM) in the positive wire
S	Fuse
Z1	Heated rear window

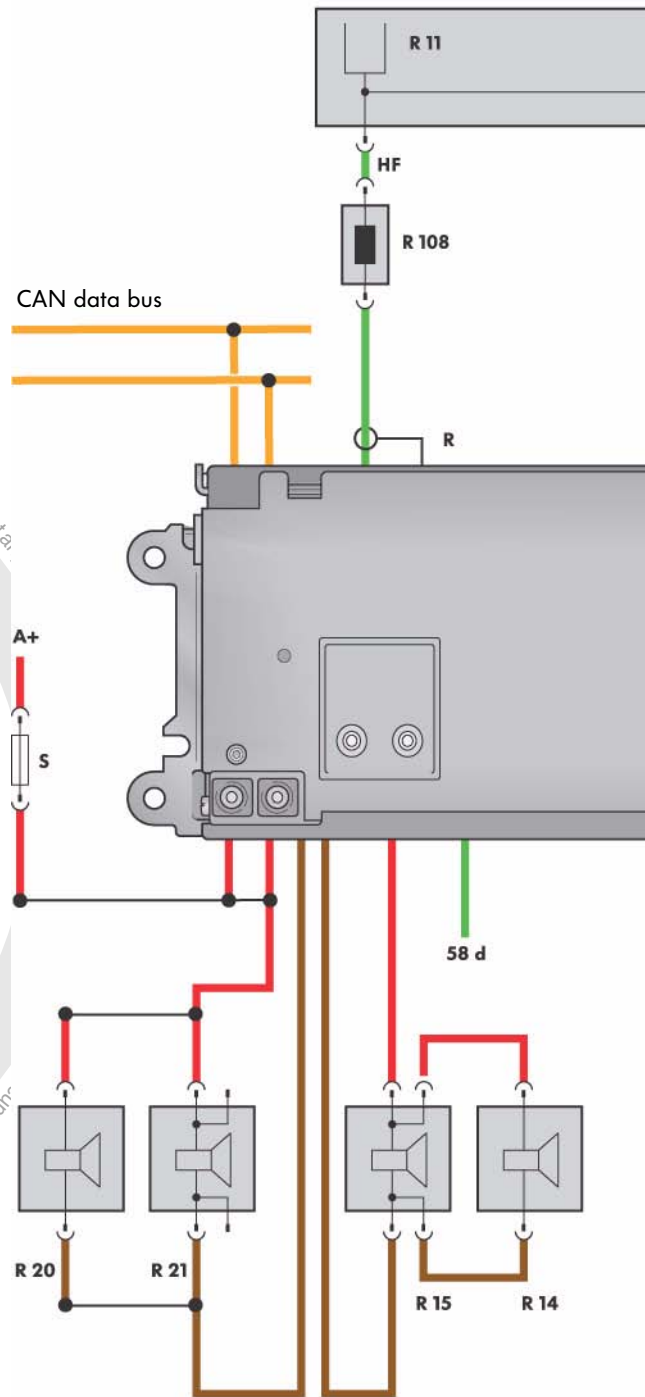

- Input signal
- Output signal
- Voltage supply (plus)
- Earth (minus)
- CAN data bus line

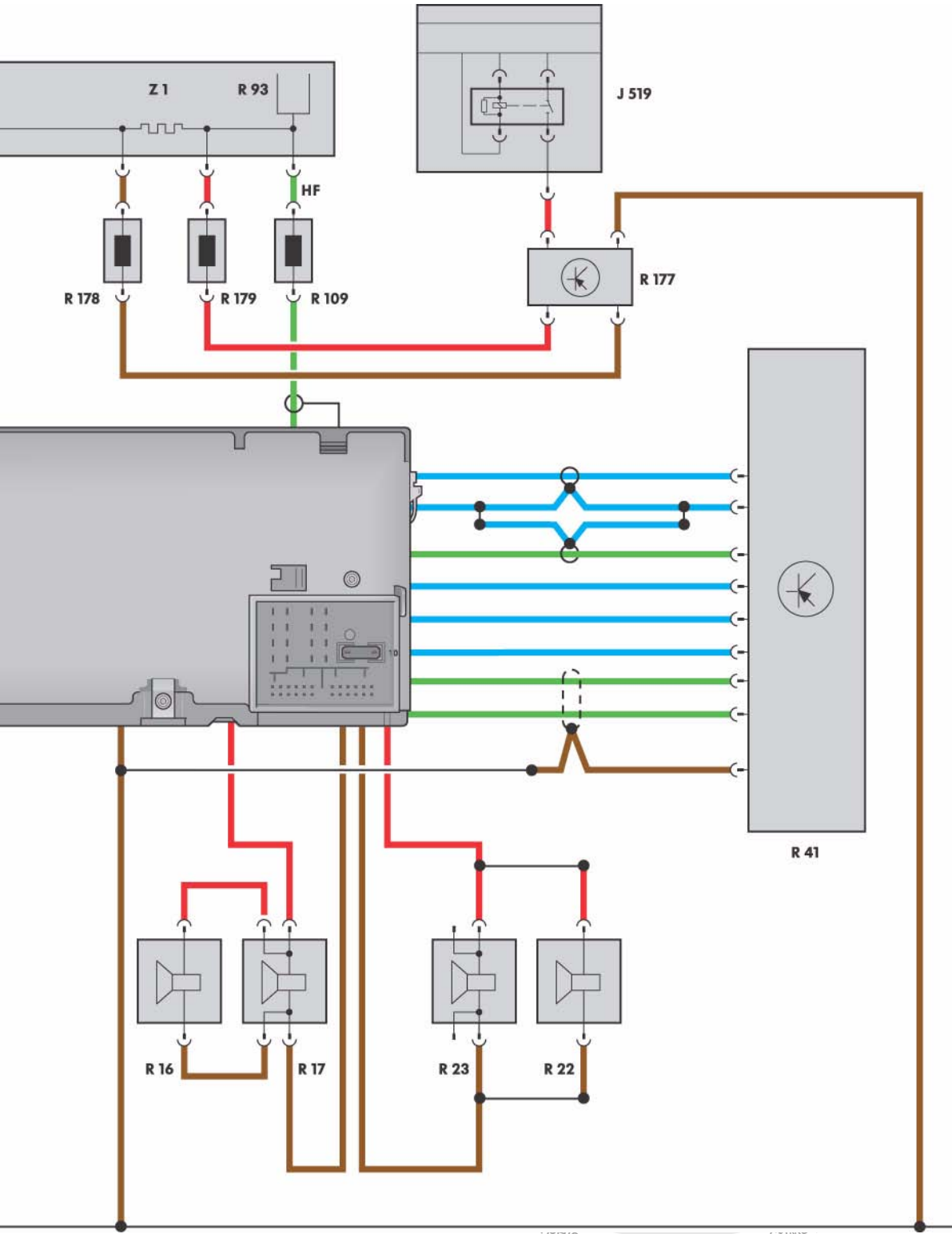

Liability with respect to the correctness of information in this document

Sound Systems

8-channel analogue amplifier

The use of external multi-channel amplifier improves the sound quality inside the car in several ways:

- Improved sound dynamics
- Car-specific sound configuration
- Greater frequency ranges
- Better sound distribution
- Authentic sound (concert hall quality)

An amplifier system is made up of the amplifier along with the treble, mid-range and bass loudspeakers.

The external amplifier generates the signal with the corresponding frequency response for the individual speaker outputs and uses 8-channel analogue technology.

It has eight internal output stages that control ten speakers via ten outputs.

The outputs for the rear bass and treble speakers are combined via an internal frequency filter.

The signal inputs on the amplifier are controlled via the speaker outputs on the radio unit or radio-navigation unit.

The radio/RNS unit needs to be coded to "Sound" so that the level of the output channels is reduced by 14 dB.

Self-diagnosis is carried out via the CAN data bus.

The 8-channel analogue sound system is available for the Passat 2006, Golf 2004, Jetta 2006 and Touran.

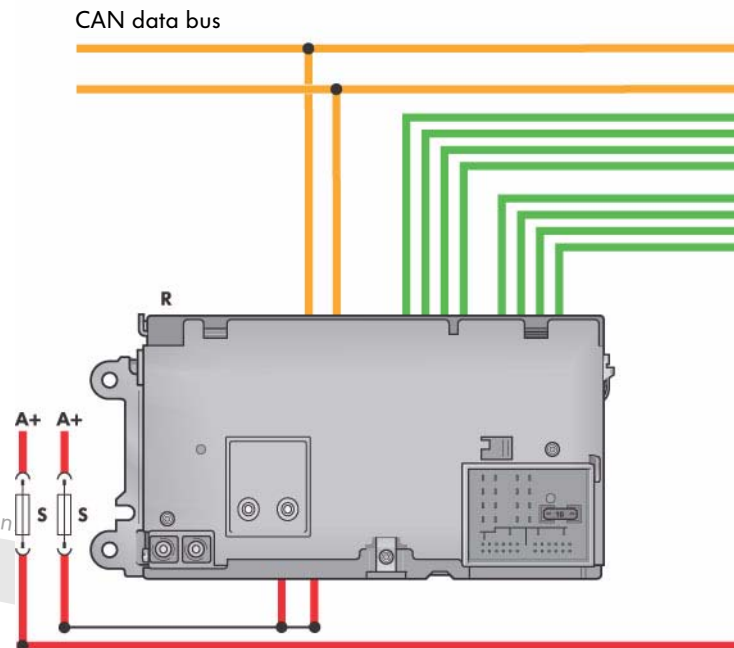

Legend

A	Battery
R	Radio
R12	Amplifier
R14	Rear left treble loudspeaker
R15	Rear left bass loudspeaker
R16	Rear right treble loudspeaker
R17	Rear right bass loudspeaker

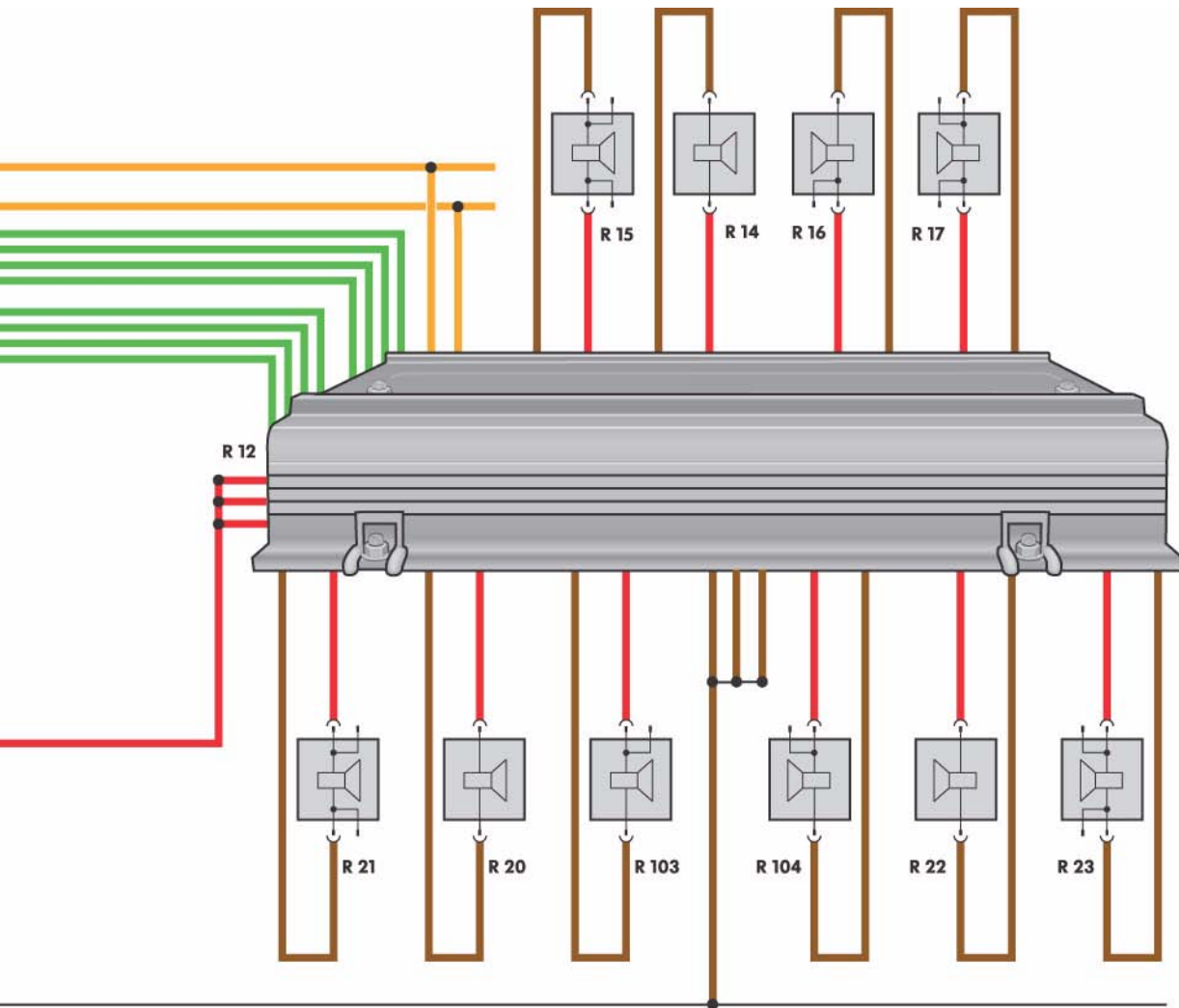

Protect to the correctness of information in this document. Copyright © 2014 Volkswagen Group of America

S342_026

- R20 Front left treble loudspeaker
- R21 Front left bass loudspeaker
- R22 Front right treble loudspeaker
- R23 Front right bass loudspeaker
- R103 Front left mid-range loudspeaker
- R104 Front right mid-range loudspeaker
- S Fuse

- Input signal
- Output signal
- Voltage supply (plus)
- Earth (minus)
- CAN data bus line



Sound Systems

10-channel digital amplifier

The 10-channel digital amplifier uses digital signal processing and supplies the connected speakers with an output power of 600 Watts.

A special switched-mode power supply in the amplifier ensures that even the top pulse overshoots are not cut off and therefore no signals for the audible frequencies are filtered.

The signal inputs on the amplifier are controlled via the speaker outputs on the radio unit or radio-navigation unit and digitally via the CAN data bus.

Self-diagnosis is carried out via the CAN data bus.

The 10-channel digital amplifier is available for the Passat 2006 with DYNAUDIO loudspeakers.

Amplifier output power:

Bass loudspeaker: 4 x 120 Watt
Mid-range loudspeaker: 2 x 30 Watt
Treble loudspeaker: 4 x 15 Watt

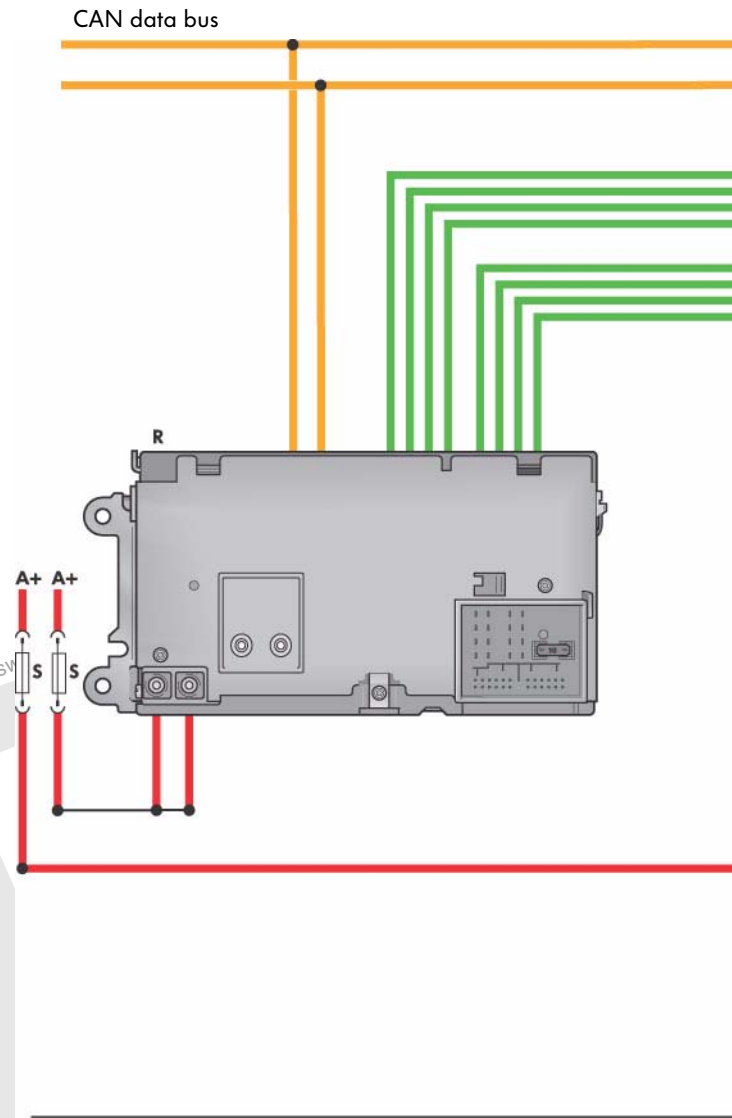

Legend

A	Battery
R	Radio
R12	Amplifier
R14	Rear left treble loudspeaker
R15	Rear left bass loudspeaker
R16	Rear right treble loudspeaker
R17	Rear right bass loudspeaker

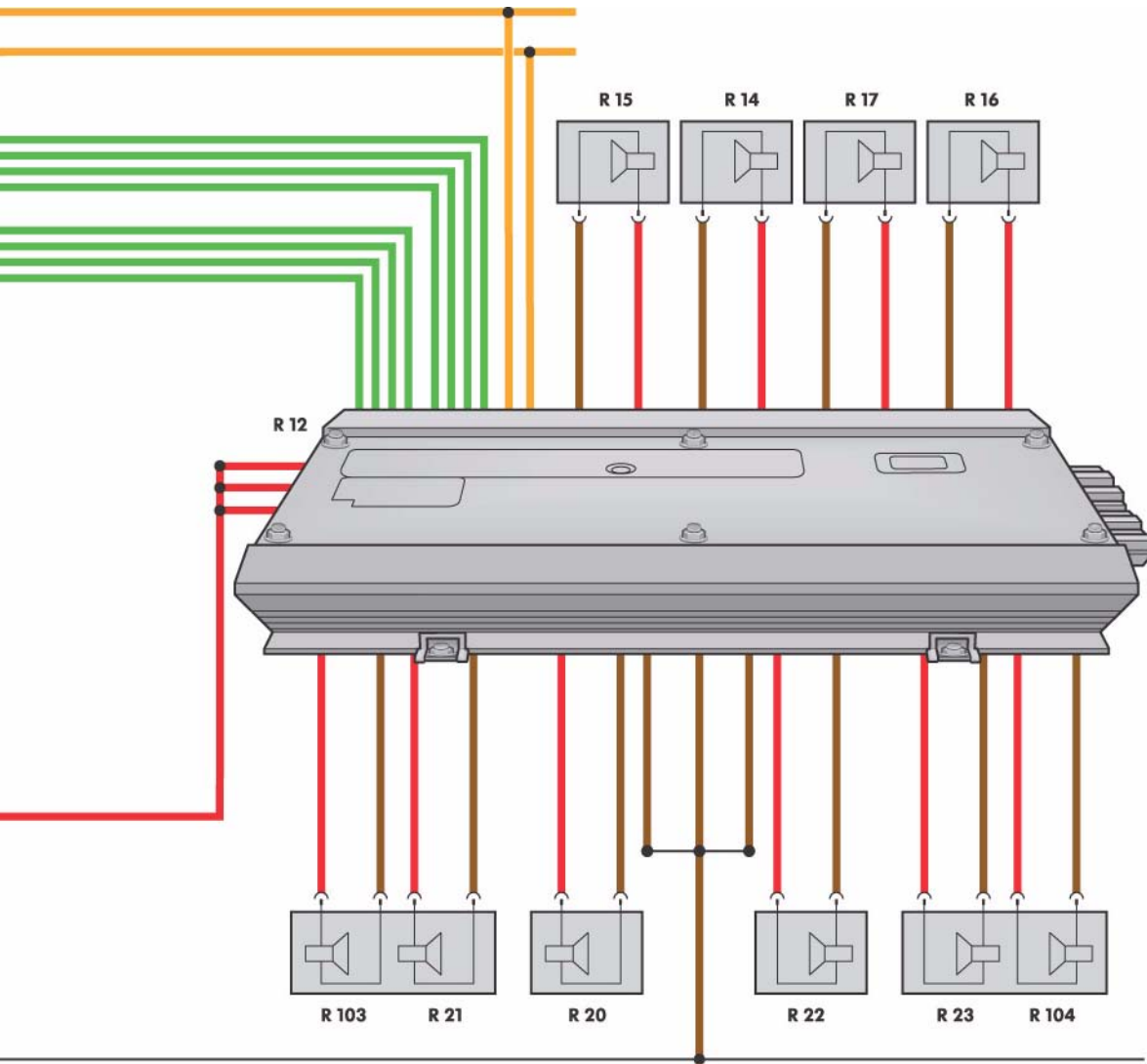

S342_053

- R20 Front left treble loudspeaker
- R21 Front left bass loudspeaker
- R22 Front right treble loudspeaker
- R23 Front right bass loudspeaker
- R103 Front left mid-range loudspeaker
- R104 Front right mid-range loudspeaker
- S Fuse

- Input signal
- Output signal
- Voltage supply (plus)
- Earth (minus)
- CAN data bus line

G does not guarantee or accept any liability with respect to the correctness of information in this document. Copyright by Volkswagen



Sound Systems

12-channel digital amplifier

The 12-channel digital amplifier is used in the Volkswagen Touareg and Volkswagen Phaeton.

It has a total of 12 outputs, to which four bass, four mid-range, one mid-range and treble and two treble loudspeakers are connected in the Touareg and four bass, four mid-range, two mid-range and treble and two treble loudspeakers are connected in the Phaeton. One channel is therefore free in the Touareg.



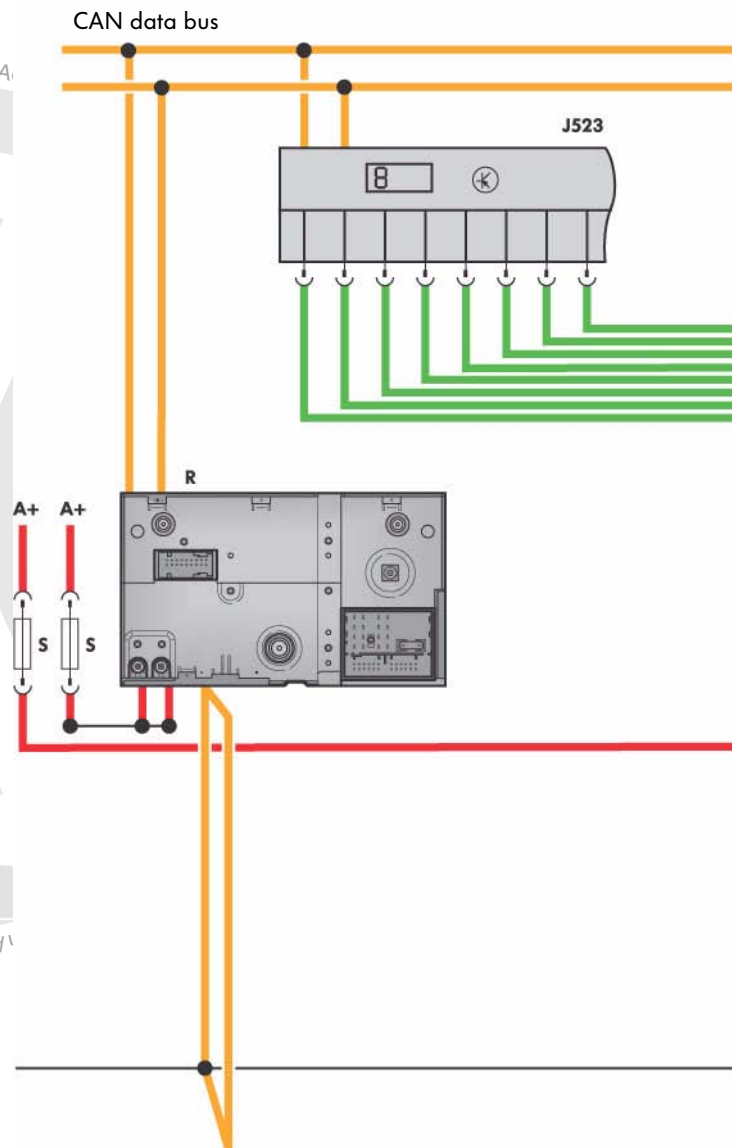

The 12-channel digital amplifier is controlled with the radio or radio-navigation unit in the Touareg digitally via the CAN data bus.

In the Phaeton, the 12-channel digital amplifier is controlled via the front information display and operating unit control unit and the CAN data bus.

Self-diagnosis is carried out via the CAN data bus.



Legend

	Input signal
	Output signal
	Voltage supply (plus)
	Earth (minus)
	CAN data bus line

A	Battery
J523	Front information display and operating unit control unit (only Phaeton)
J525	Digital sound package control unit (only Phaeton)
R	Radio
R12	Amplifier
R15	Rear left bass loudspeaker

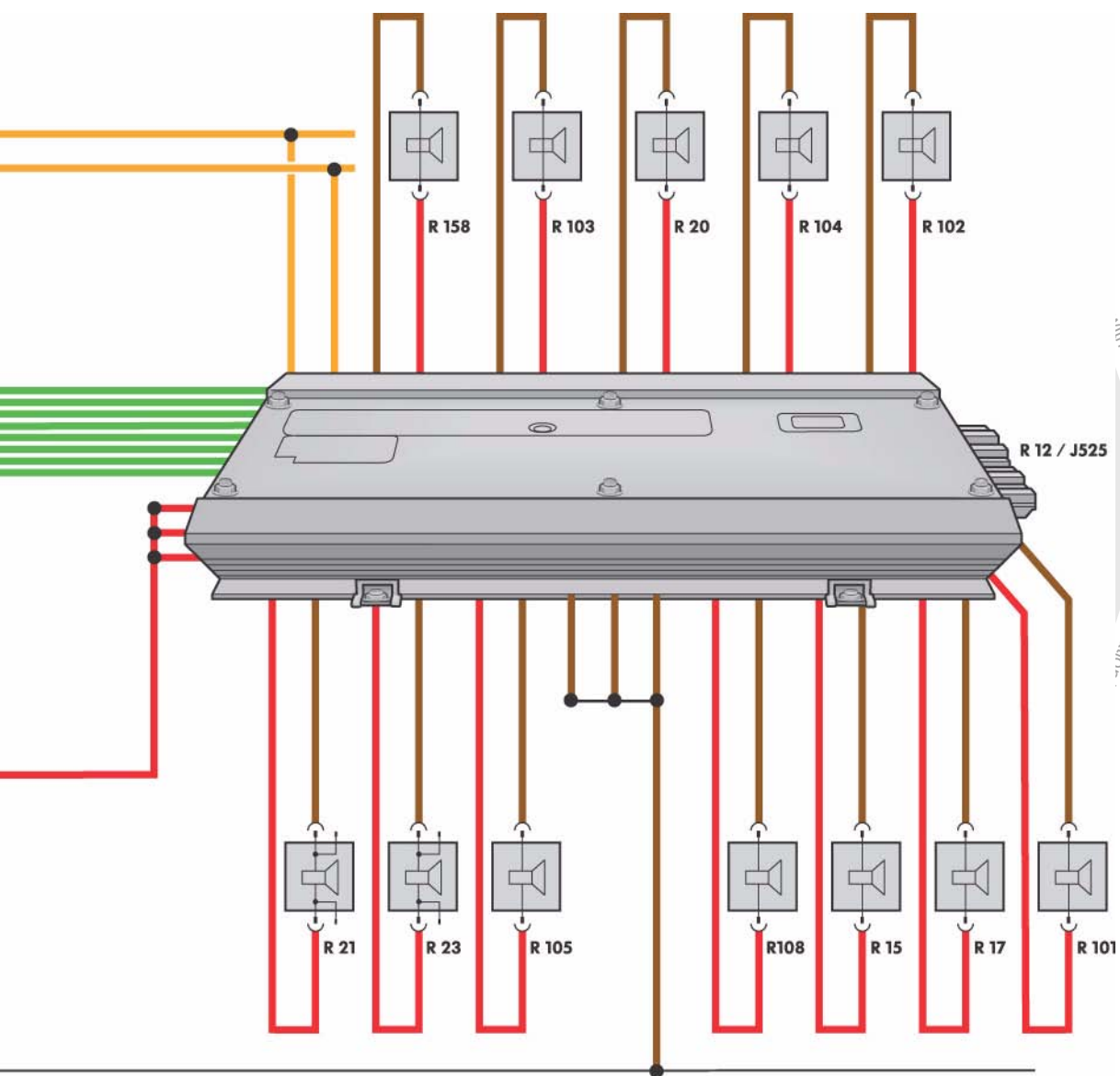

...with respect to the correctness of Information...



S342_046

- | | | | |
|------|--|------|---|
| R17 | Rear right bass loudspeaker | R103 | Front left mid-range loudspeaker |
| R20 | Front left treble loudspeaker | R104 | Front right mid-range loudspeaker |
| R21 | Front left bass loudspeaker | R105 | Rear left mid-range loudspeaker |
| R22 | Front right treble loudspeaker | R106 | Rear right mid-range loudspeaker |
| R23 | Front right bass loudspeaker | R158 | Centre mid-range and treble loudspeaker
(Touareg only) |
| R101 | Front left mid-range and bass loudspeaker
(only Phaeton) | S | Fuse |
| R102 | Front right mid-range and bass loudspeaker
(only Phaeton) | | |

Sound Systems

10-channel DYNAUDIO high-end system

Due to the different locations of the speakers and the different materials (e.g. soft seats and hard windows), configuring an ideal sound inside a vehicle is very difficult.

The careful positioning of ten speakers allows balanced sound distribution in the whole interior.

The continuous output of the DYNAUDIO 10-channel high-end systems is 600 W. This is distributed in different ways between the individual outputs as, for example, the treble speakers have the highest wattage.

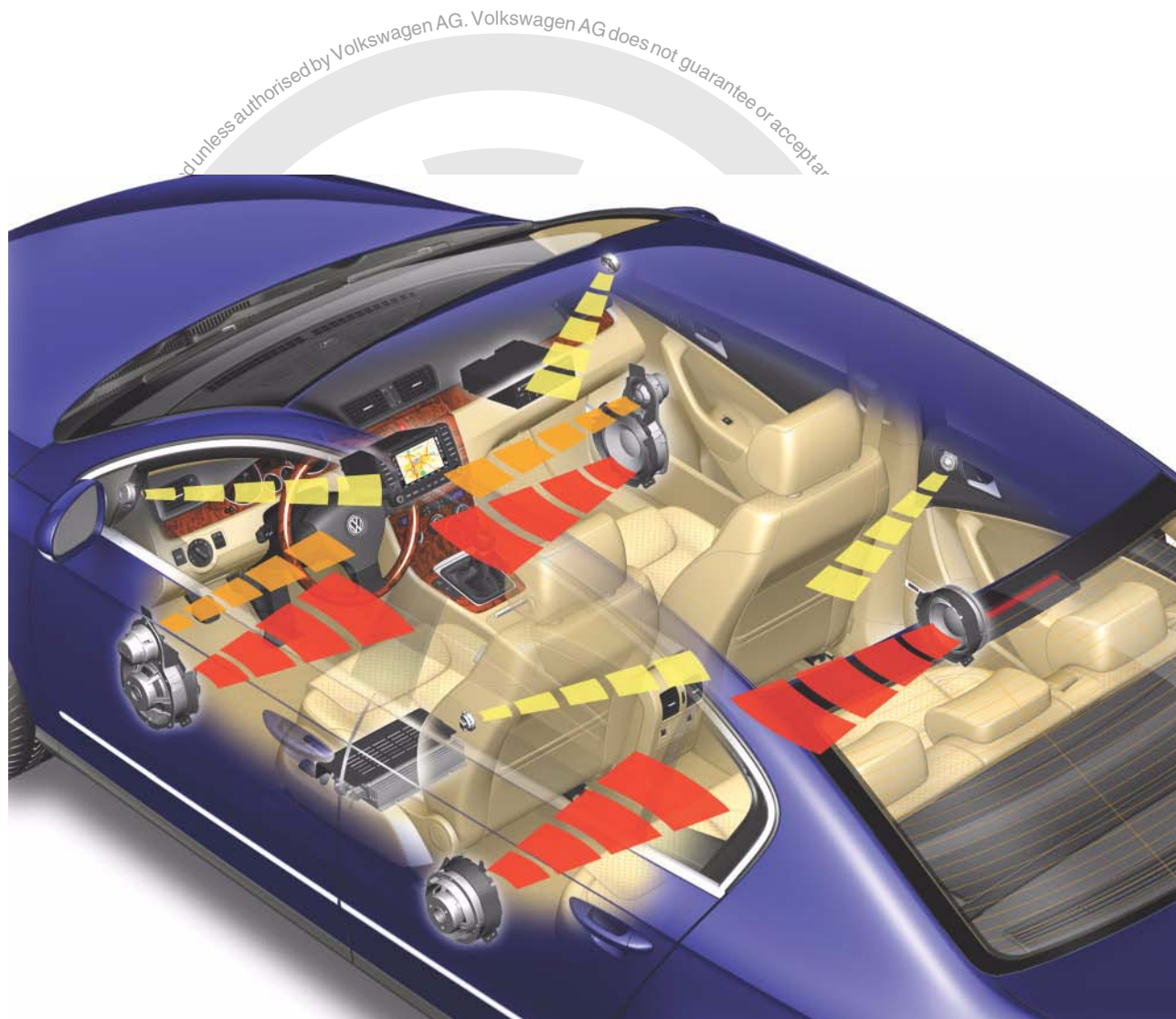

S342_038

The DYNAUDIO brand is a guarantee of high-quality sound. DYNAUDIO uses the lightest materials, i.e. the surface emitting the sound is enlarged three to four times while keeping the same speaker weight. The effectiveness is thus increased three to four times. Also the whole area of the single-piece diaphragm is part of the polar pattern. The coil design and magnet construction leads to linear pattern across the whole frequency range resulting in perfect diffusion and better thermal loading capacity (heat discharge).

Speaker concept

To obtain a deep, but also precise bass sound, a total of four bass speakers have been anchored with DYNAUDIO's MSP membranes in the door construction with low-resonance.

For an open and clear mid-range two extra large mid-range speakers with textile cones (80 mm) are mounted in the front doors.

Two 20 cm bass speakers are fitted in the front doors and two 16.8 cm bass speakers in the rear.



Filigree treble information is a basic requirement for authentic music playback. Therefore two 48 mm textile treble speakers share the work with the high frequencies in the front.

As high frequencies tend to travel in one physical direction, two 40 mm variants at the rear of the vehicle support this important frequency range. The weight advantage (aluminium instead of copper) is used in favour of a longer coil. This allows linear dynamics even at the top levels.

The dome in the treble speakers is made from textile instead of plastic.

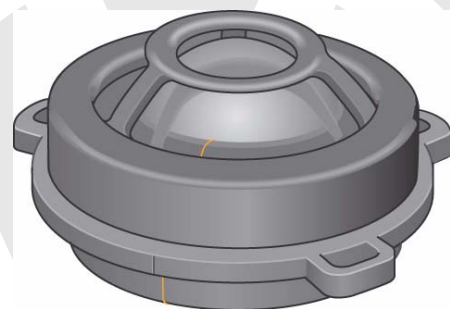

S342_039

S342_040

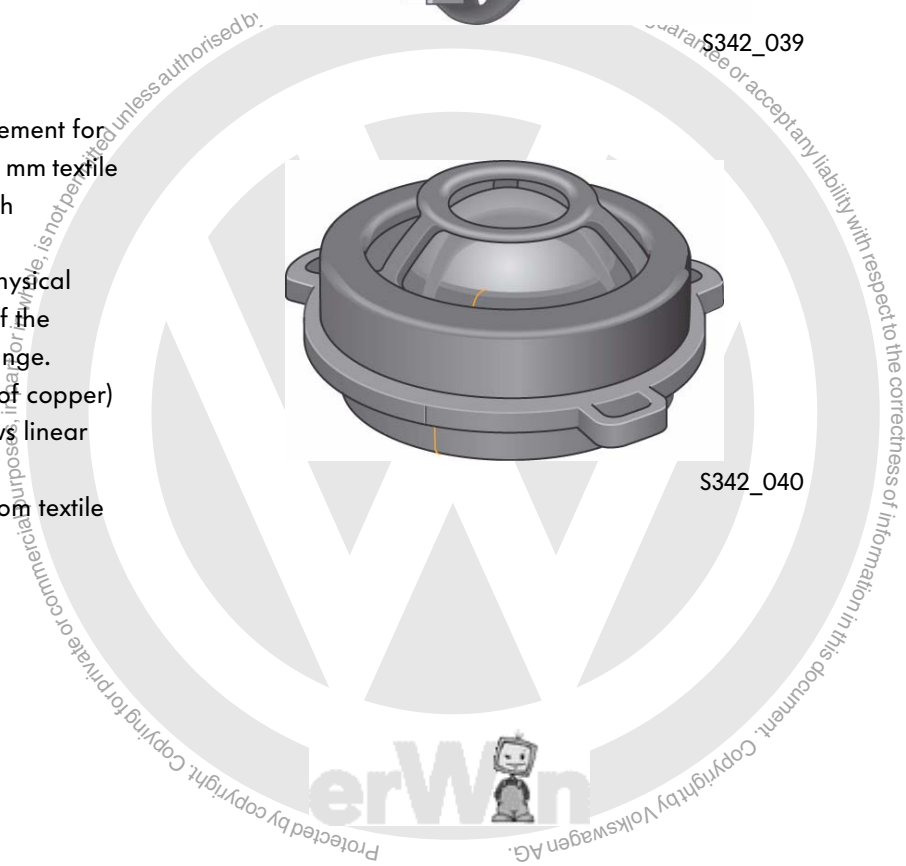

Sound Systems

Digital Signal Processing (DSP)

DSP technology means that the sound curves can be programmed individually in the amplifier for each speaker output. There are therefore special characteristic curves for each type of vehicle as the signal from each audio channel is prepared specifically.

The aim of vehicle-specific sound configuration is to generate as authentic a sound as possible on a virtual stage in front of the occupants.

Filter stages

The sound is processed in the filter stages. The signal amplitudes are reduced or amplified in certain frequency ranges in up to five downstream filter stages.

Time-delay element

The signals for the rear speakers are delayed in the time-delay element by several milliseconds so that concert hall characteristics are created inside the vehicle.

Amplifier

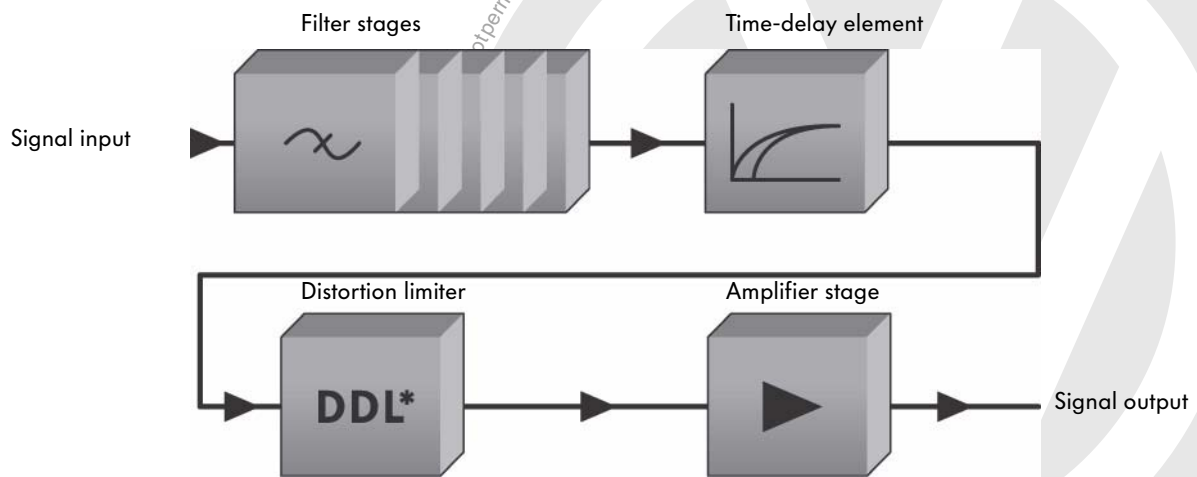

* DDL - Dynamic Distortion Limiter

S342_047

Distortion limiter

Distortion can occur in the sound processing. This is reduced in the distortion limiter, which also keeps the harmonic distortion low.

Amplifier stage

The incoming signal from the radio is amplified in the amplifier stage and sent to the outputs.

Sound curve

The sound curve is specially configured for the vehicle interior and stored in a characteristic curve in the amplifier. In this way, frequency ranges where there is a risk of interior components resonating are reduced and other frequencies, which could be weakened by sound absorbing components, are increased.

Sound curve graph

Amplification dB

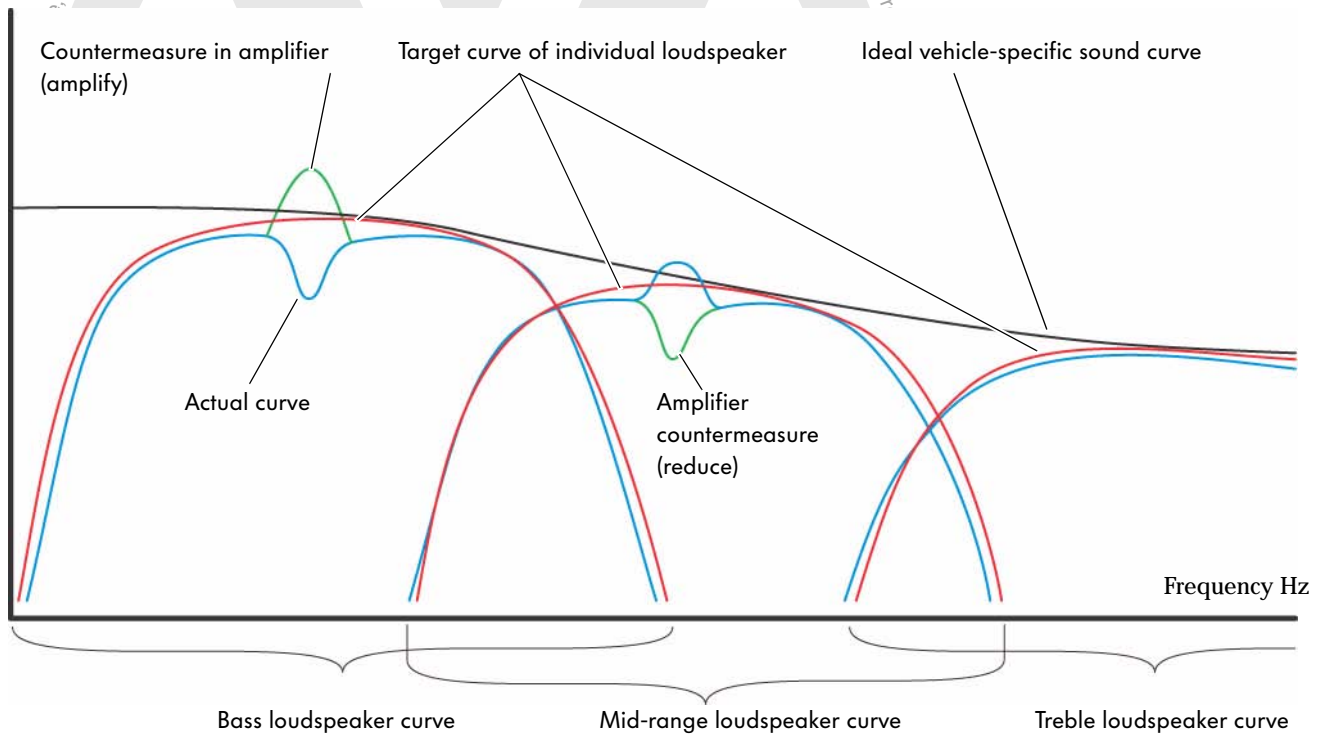

S342_048

The actual sound curve (blue) is dependent on the interior characteristics. It is raised in the bass area and is thus configured for the human ear.



The sound delay of the rear speakers is maintained by the time-delay element regardless of the fader setting.



Sound Systems

Speaker locations

Golf 2004 loudspeaker system

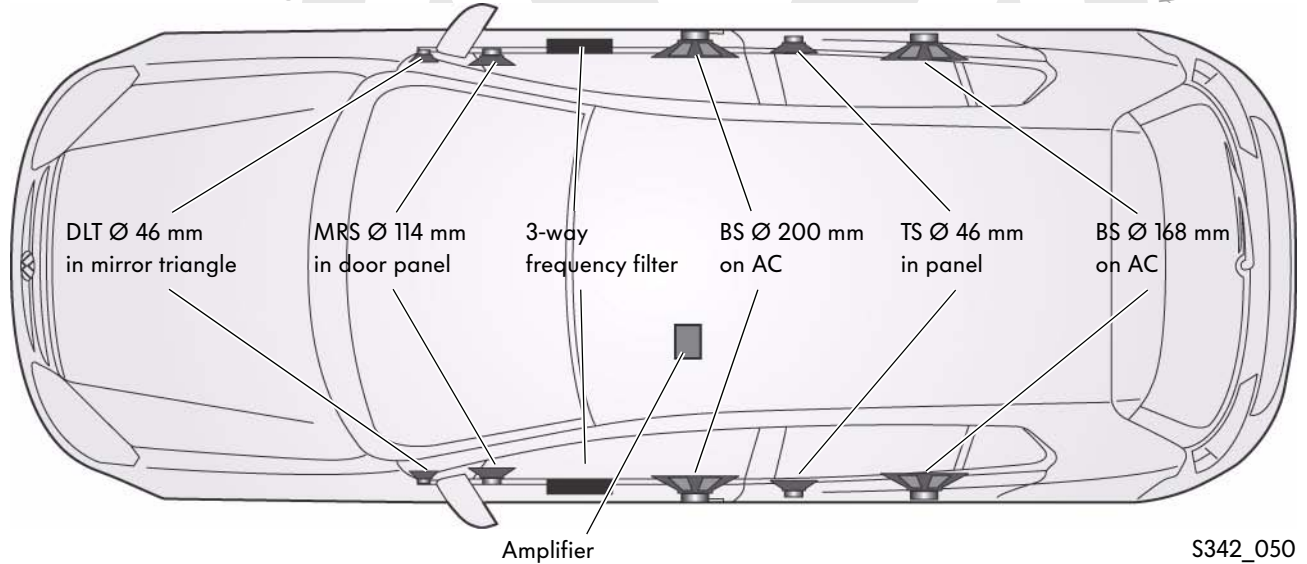

S342_050

Legend

DTL Domed treble loudspeaker
MRS Mid-range loudspeaker

BS Bass loudspeaker
TS Treble loudspeaker
AC Assembly carrier

Passat 2006 basic speaker system

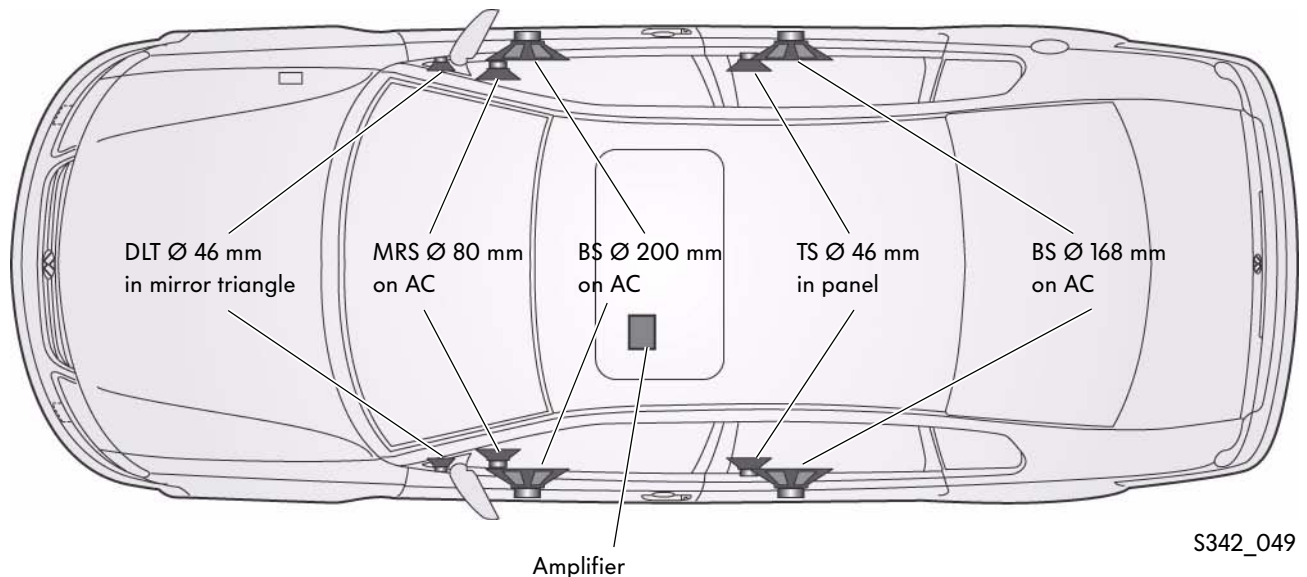

S342_049

Legend

DTL Domed treble loudspeaker
MRS Mid-range loudspeaker

BS Bass loudspeaker
TS Treble loudspeaker
AC Assembly carrier

Touareg speaker system

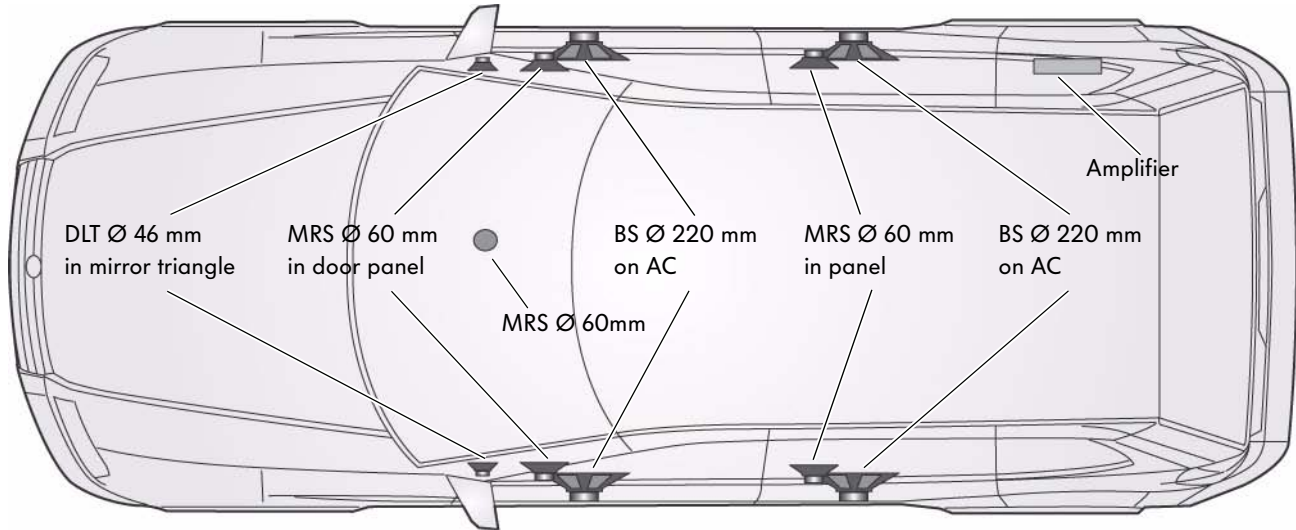

S342_051

Legend

DTL	Domed treble loudspeaker	BS	Bass speaker
MRS	Mid-range speaker	TS	Treble speaker
		AC	Assembly carrier

Phaeton speaker system

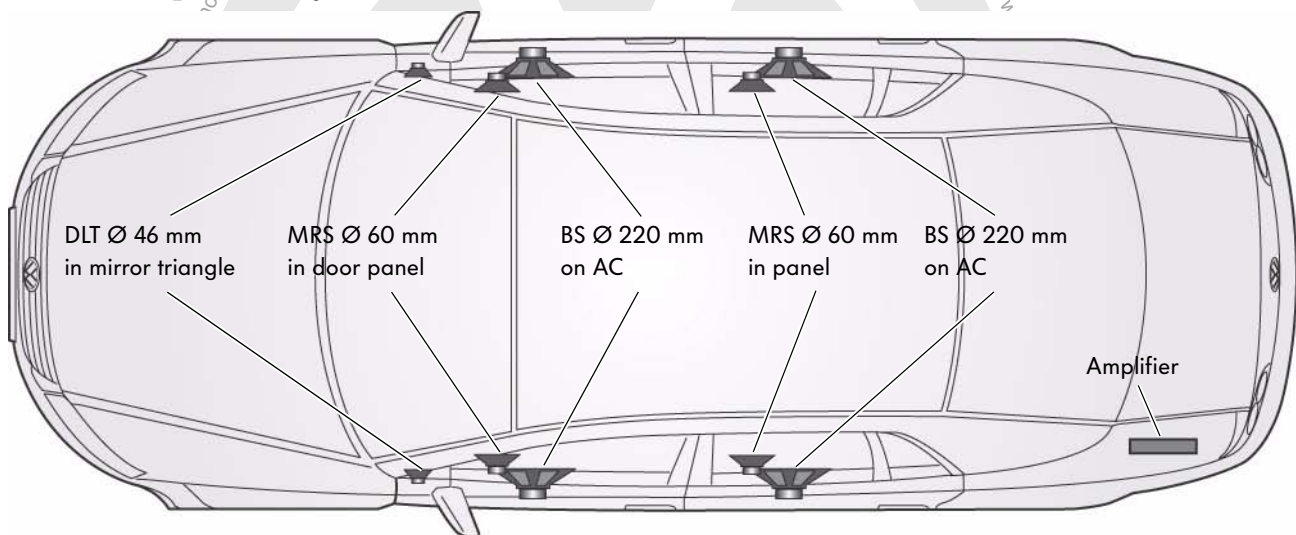

S342_052

Legend

DTL	Domed treble loudspeaker	BS	Bass loudspeaker
MRS	Mid-range loudspeaker	TS	Treble loudspeaker
		AC	Assembly carrier



Aerial Systems

Aerial systems for the Golf/Golf Plus

Vehicles without radio and radio preparation

If the Golf or Golf Plus is ordered without a radio/ radio preparation, there will not be an aerial connection on the left of the rear windscreen. The basic aerial structure in the rear windscreen is always included and identical in specific models. The structure is made up of horizontal and vertical reception wires. The horizontal wires are used to receive horizontally polarised signals and the vertical wires receive vertically polarised signals.

There is a hole for the aerial in the roof that is sealed with a plug. The plug is shaped like an aerial (shark fin). It can be replaced with a roof aerial.

Decoupling point/connecting point for aerial (as high as possible for better reception)

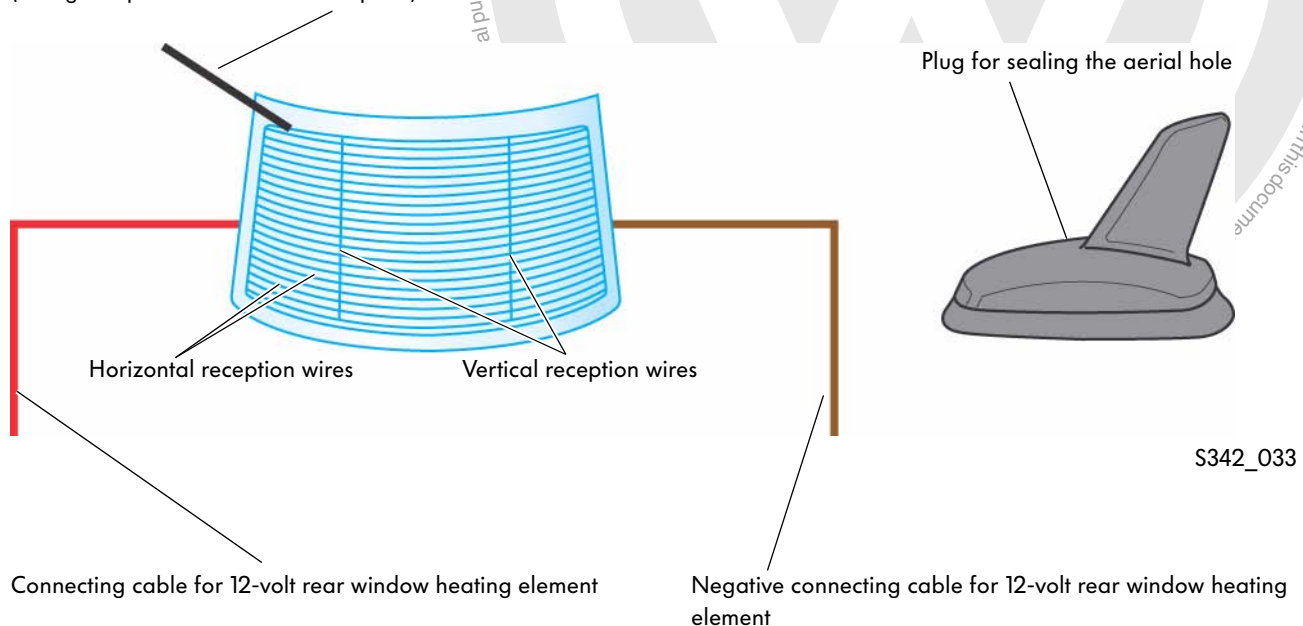

The aerial wiring is missing in this setup and needs to be fitted if a radio is retrofitted.

Vehicles with single-tuner radios without telephone, navigation, remote start

Cars that are ordered with the R 100 and RCD 200 (radios with single-tuner concept) radios come with a mast-type roof aerial. The rear windscreen is identical to that on the vehicles without a radio. AM and FM rejector circuits are not needed due to the mast-type aerial being electrically isolated from the heated rear windscreen. The reception is just as good as a windscreen aerial.

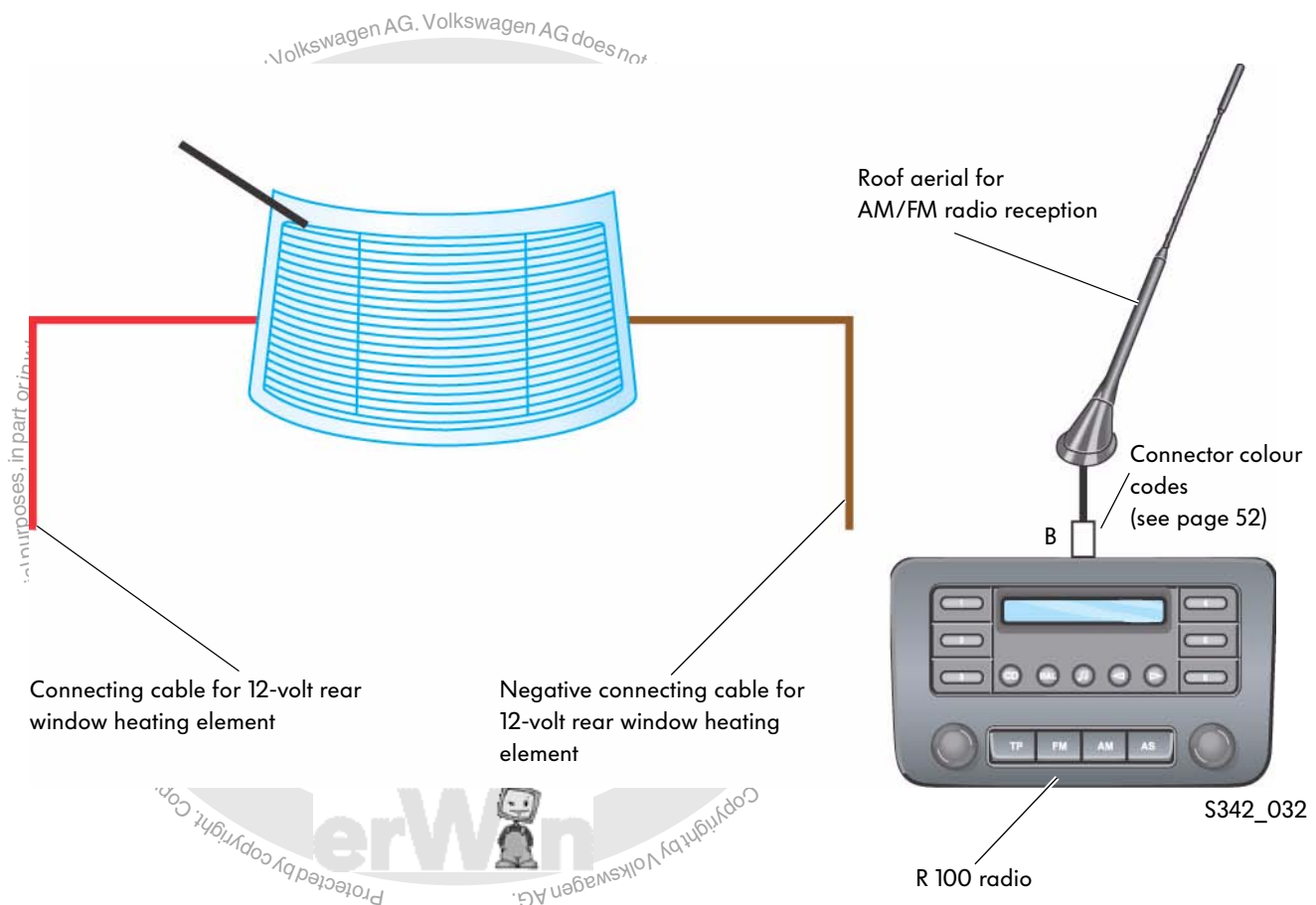

Only one rear windscreen version with two aerial connection litz wires is available as a customer service replacement.

Aerial Systems

Vehicles with dual-tuner radios without telephone, remote start and navigation

The RCD 300 and RCD 500 radio systems require two aerials for their internal dual-tuner diversity receiver.

They use a rear windscreen aerial and a mast-type aerial on the roof as standard.

The rear windscreen aerial needs at least one connecting wire to be connected to the aerial structure. If there are two connecting litz wires on the rear windscreen, the aerial will be connected on the left.

Windscreen aerial for FM radio reception

FM impedance transformer (aerial amplifier)

Roof aerial for AM/FM radio reception

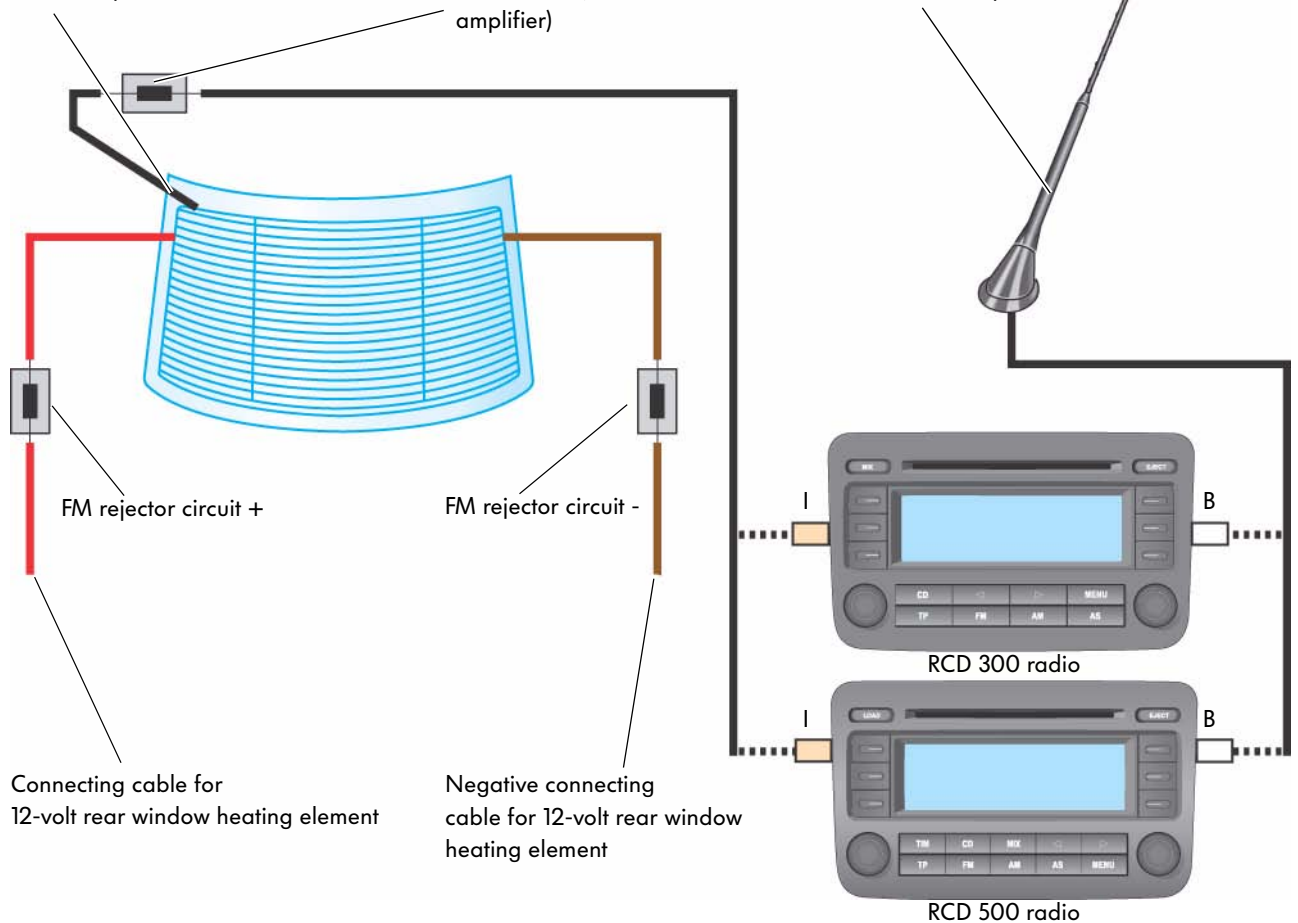

S342_035

Vehicles with single-tuner radios with telephone, remote start and/or navigation

As the roof aerial is needed for telephone, remote start and navigation, radio signals need to be received via the rear windscreen aerial.

A roof aerial is needed to receive the satellite signals for navigation, the telephone signals and the signal to activate the auxiliary heating (remote start).

The signals are decoupled via a filter switch if the car is equipped with a telephone and remote start.

-authorised by Volkswagen AG. Volkswagen AG does not guarantee or-

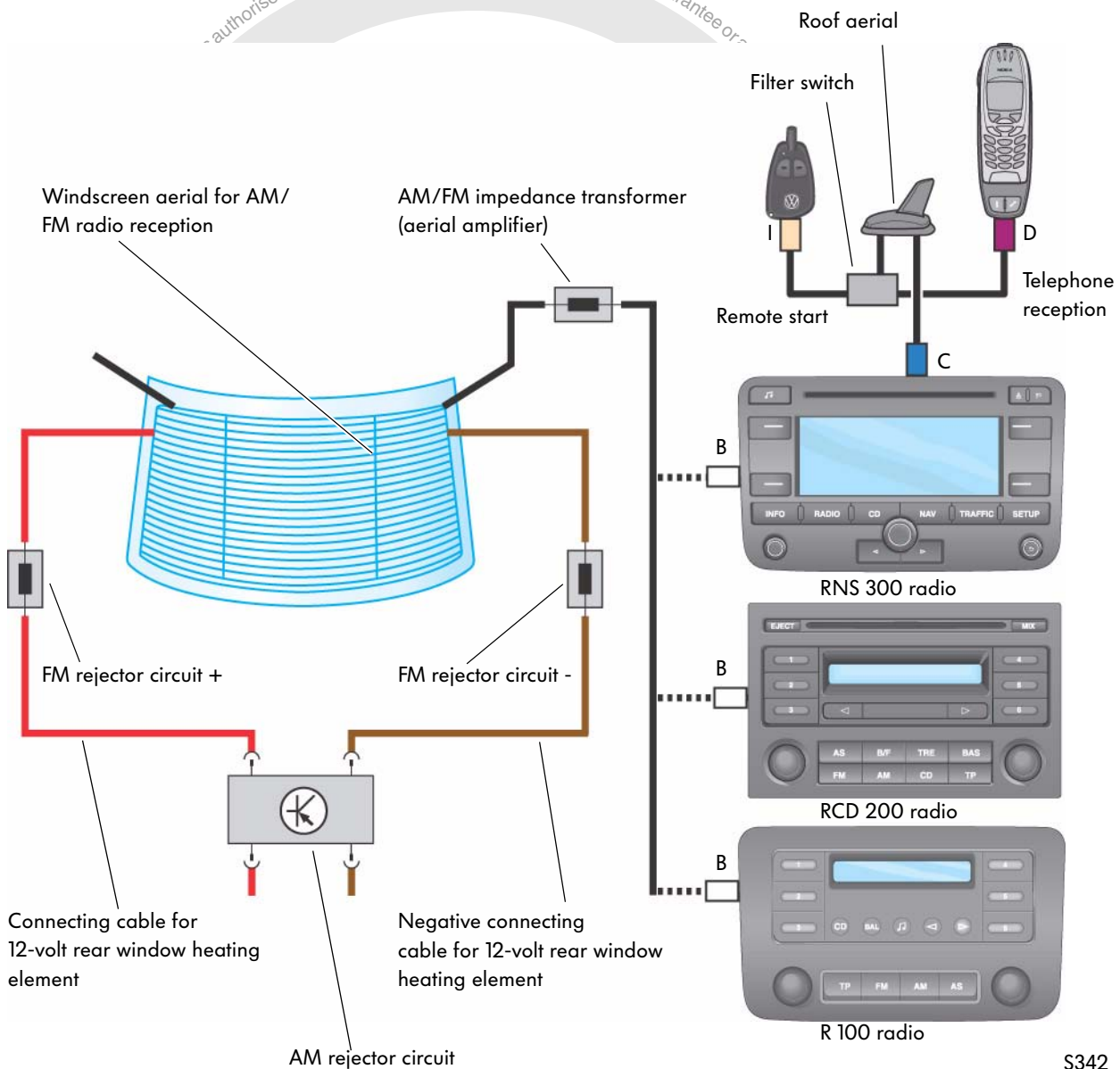

S342_034



Aerial Systems

Vehicles with diversity and telephone, remote start and/or navigation

The GPS satellite signals for navigation and the telephone signals for calls and activating the auxiliary heating are received via the roof aerial.

Two aerials, located in the rear windscreen, are used to receive the radio signals for the two-tuner diversity receiver.

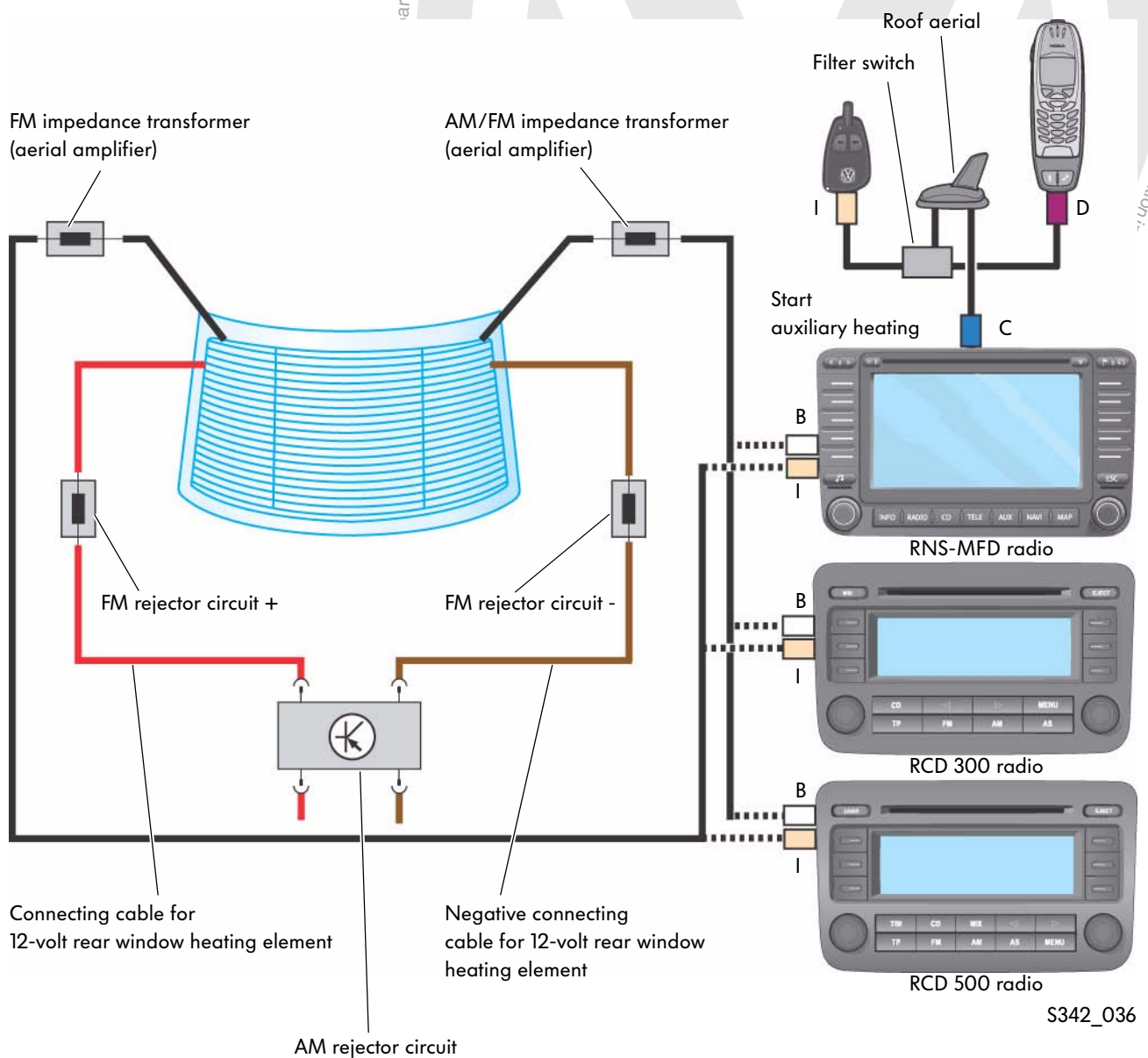

Aerial systems for the Passat 2006 and Jetta 2006

Rear windscreen

There are three types of rear windscreen:

- Rear windscreen without rejector circuits and module mountings
- Rear windscreen with rejector circuits without GPS and GSM modules
- Rear windscreen with rejector circuits with GPS and GSM modules

The contact surfaces for the aerial modules are present on each of the windscreens and the modules can be retrofitted. The wiring is only provided for the ordered equipment version — wires have to be laid when retrofitting.

Windscreen layout

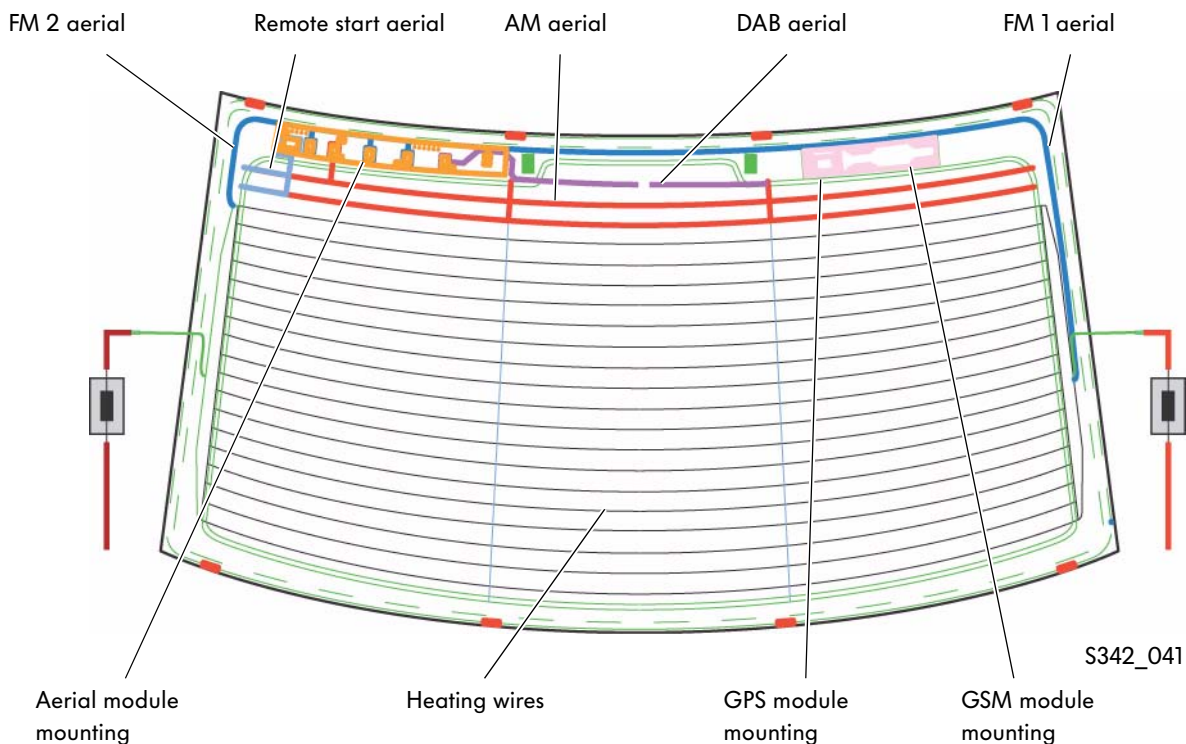

This view of the rear windscreen is from inside the car.

Aerial Systems

Variants

As the mountings for the GSM and GPS modules are simply fastenings and are electrically isolated from the rear windscreen, the installation of the module does not depend on the radio and aerial concept and is only shown as an example in the following diagrams.

Vehicles with single-tuner radios and telephone without remote start and/or navigation

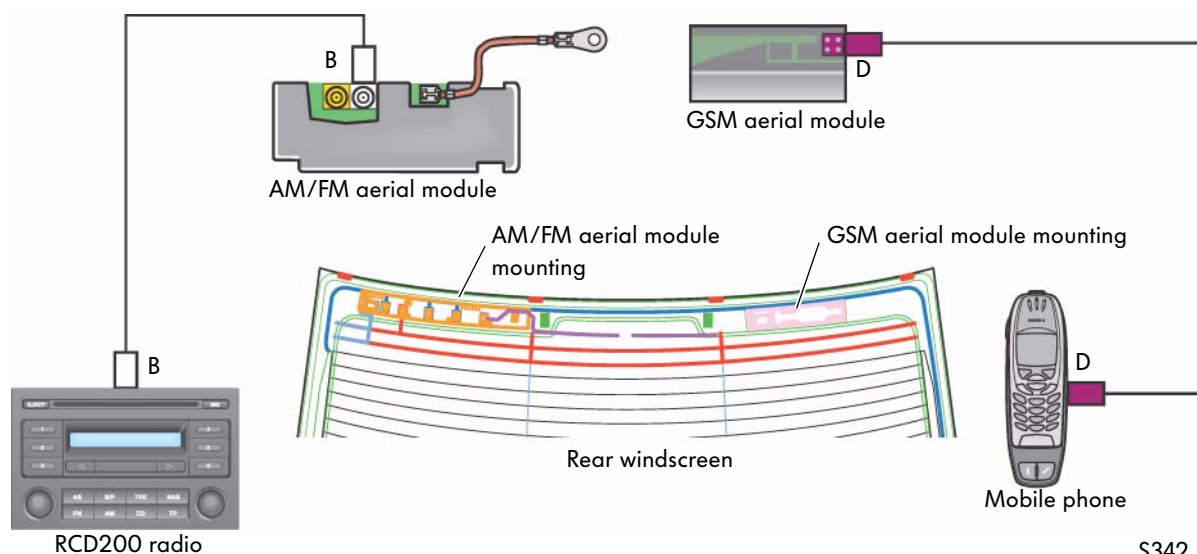

S342_042

Vehicles with single-tuner radios and telephone, remote start and navigation

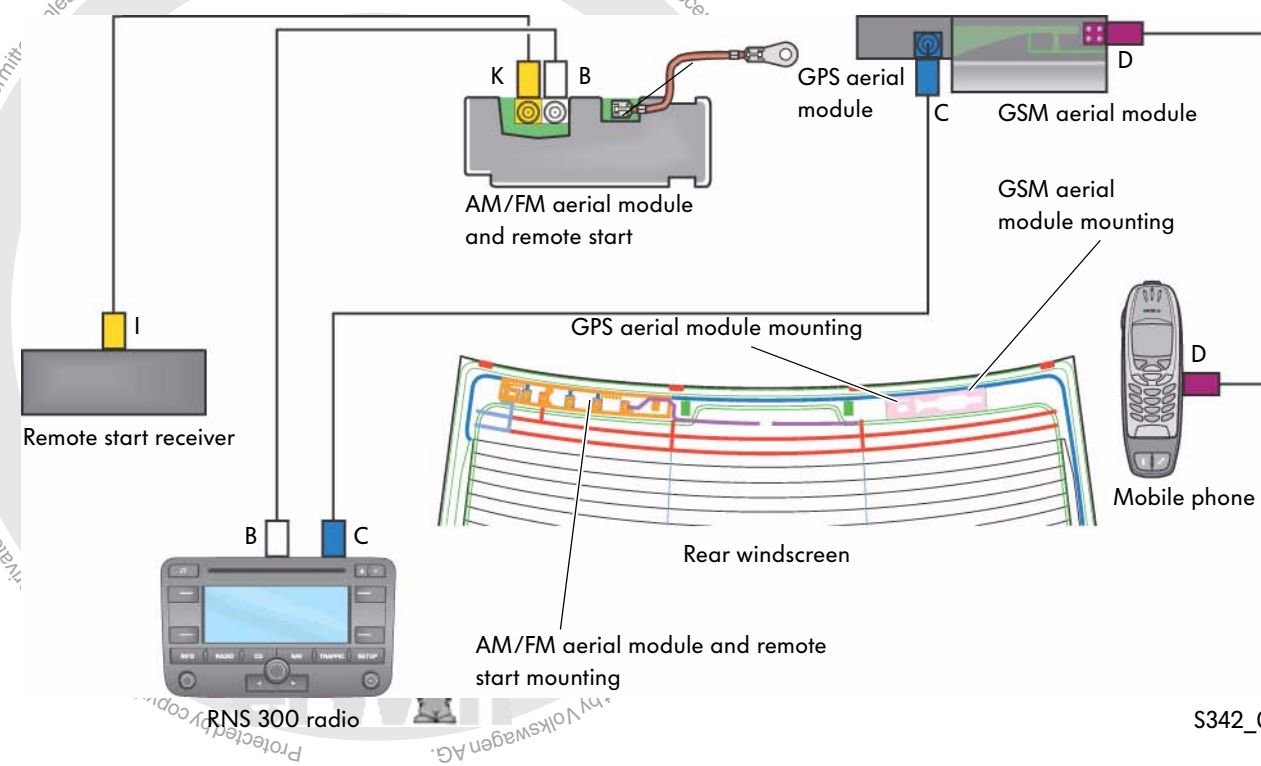

S342_043

Vehicles with diversity and telephone without remote start and/or navigation

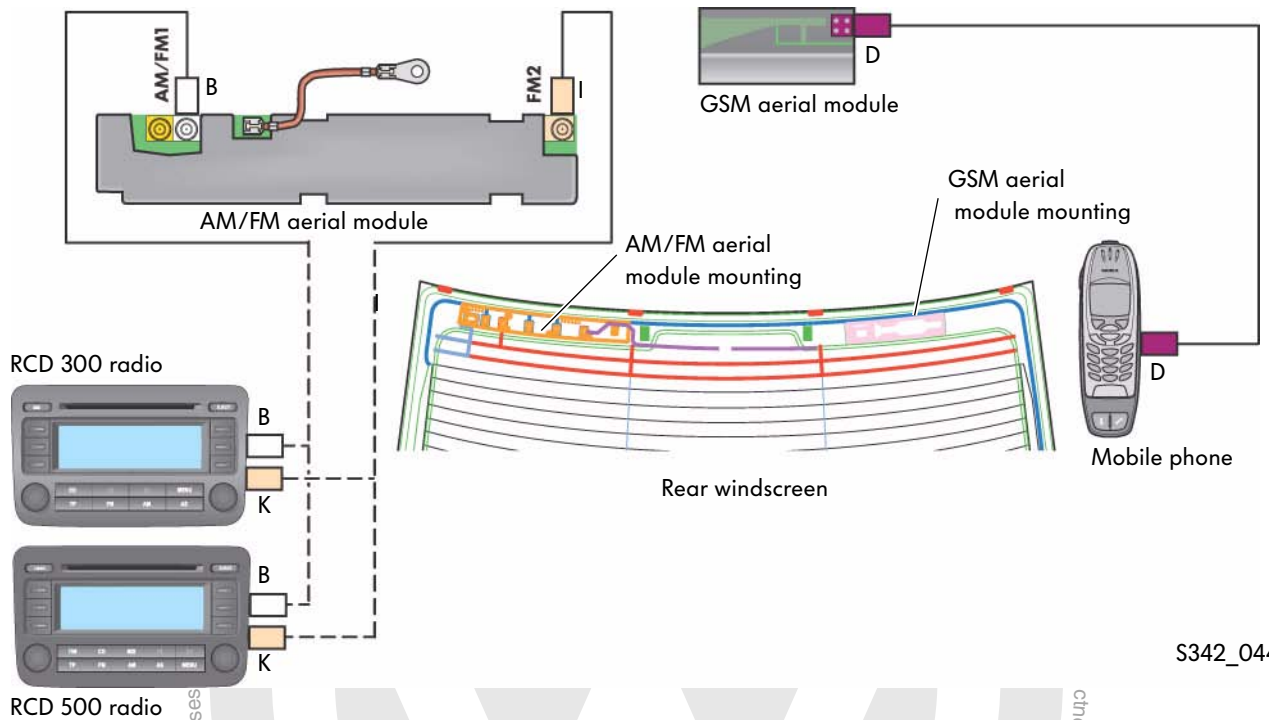

S342_044

Vehicles with diversity and telephone and/or navigation without remote start

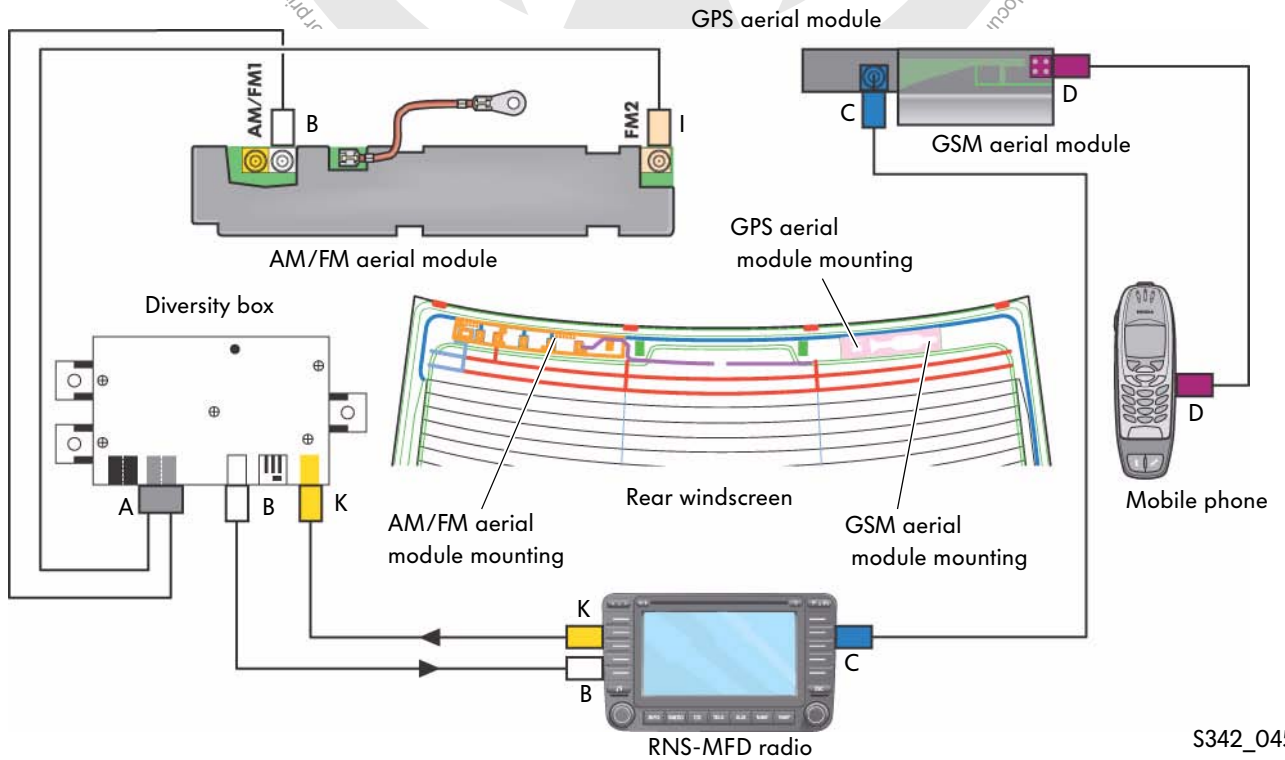

S342_045

















Aerial Systems













Aerial connection systems

FAKRA connectors are used to connect the aerals. These connectors are standardised and identical for all vehicle manufacturers and system or component producers.

Table of aerial connector codes

Code		Use 1-pole	Colour	Use 1 Coded side 2-pole 8 mm	Use 2
A		Radio without supply voltage	Jet black RAL 9005 	FM	AM/FM
B		Radio supply voltage	Cream RAL 9001 	FM	FM
C		GPS All except GPS for telematics and navigation	Signal blue RAL 5005 	TV	TV
D		Telephone	Claret violet RAL 4004 	TV	TV
E		TV	Leaf green RAL 6002 	TV	TV
F		TV	Nut brown RAL 8011 	TV	TV
G		Remote control Central locking (Kessy)	Blue grey RAL 7031 		



Code		Use 1-pole	Colour	Use 1 Coded side 2-pole 8 mm	Use 2
H		GPS for telematics and navigation	Heather violet RAL 4003 		
I		Code I for auxiliary aerial Diversity Auxiliary heating remote control	Beige RAL 1001 		
K		Radio with IF output (aerial diversity)	Curry RAL 1027 	Radio IF	Radio IF
L			Carmine red RAL 3002 		
M			Pastel orange RAL 2003 		
N			Pastel green RAL 6019 		
Z		Zero coding	Water blue RAL 5021 		



Glossary

AM

Amplitude modulation, electromagnetic wave used to transmit messages. In amplitude modulation, the amplitude of the high frequency is varied.

Amplitude

The maximum extent of a sinusoidal wave.

Bass loudspeaker

Speakers for reproducing low frequencies (approx. 40 Hz to 600 Hz).

Convenience code

If the radio unit was removed or the car battery disconnected, the anti-theft code does not need to be entered manually as the code number was stored after the first time it was entered in the car.

However, if the vehicle and radio code numbers do not match up, for example, because the radio has been fitted in another vehicle, the electronic lock will have to be removed manually.

Domed treble loudspeaker

This speaker has a dome shape.

FM

Frequency modulation, electromagnetic wave used to transmit messages.

In frequency modulation, the frequency of the carrier wave varies in step with the information signal. The amplitude remains constant.

Frequency

The rate of signal oscillations per second.

Frequency filter

A frequency filter (also called a diplexer) splits up the working ranges of the frequency band between the bass, midrange and treble speakers.

GSM

Global System for Mobile Communications or Groupe Special Mobile, standard for global mobile telecommunications.

GPS

Global Positioning System, a satellite system set up by the US Department of Defense that aids navigation.

Hertz

Unit of measurement for frequency.

1 Hz corresponds with one oscillation per second.



Limit frequency

Frequency, at which a filter starts acting.
Generally the frequency, at which the output signal of a circuit falls 3 dB below the original value.

Mid-range speaker

Speakers for reproducing mid-range frequencies (approx. 600 Hz to 4,000 Hz).

MSP diaphragm

Magnesium silicate polymer (MSP) diaphragm for precise reproduction of bass tones. It is also very light and durable.

Polarisation

Oscillation of the electrical field vector of an electromagnetic wave in a distant field.
There is a distinction between linear (vertical, horizontal) or circular (right and left rotating) polarisation.

RCD 300 radio driving school version

The car speed and the operation of the turn signal (static arrow pointing left or right) appear in the radio display.

RDS, Radio Data System

This system allows a transmitter to transmit an inaudible "data telegram" with control information to the radio in addition to the FM radio programme. (see SSP 147 Radio Systems '94)

Redundant

In electronics, a redundant signal is a signal that is doubled for security reasons.

Rejector circuit

A rejector circuit in a vehicle blocks certain frequencies and thus isolates the heating wires in the rear windscreen from the rest of the electrical system. Otherwise there would be a risk of the whole aerial being short-circuited. AM and FM rejector circuits are low-resistance for the direct voltage.

Transport mode

Various electrical consumers are switched off to minimise power consumption. The transport mode is, as the name suggests, activated during transport to the dealership or during longer periods when the vehicle is not used.
Depending on the vehicle type, it only needs to be activated up to a certain mileage.
Use the instructions from the ELSA to activate or deactivate it.

Treble loudspeaker

Speakers for reproducing high frequencies (approx. 4,000 Hz to 20,000 Hz).



Test Yourself

1. What is amplitude modulation?

- a) The oscillation of the sinusoidal amplitude is converted into square waves.
- b) The amplitude of the high frequency is varied in amplitude modulation.
- c) The frequency of the oscillations is doubled by the highcut.
- d) The amplitude of the low frequency is varied in amplitude modulation.

2. What is frequency modulation?

- a) The frequency of the amplitude is varied in frequency modulation.
- b) The amplitude of the mid-range frequency is varied in frequency modulation.
- c) The cosinoidal oscillation is transformed sinusoidally into digital square-wave signals.
- d) In frequency modulation, the frequency of the carrier wave varies in step with the information signal.

3. What is a highcut?

- a) Multipath interference in the upper frequency range is "cut".
- b) Voltage peaks (high) occurring in the car are cut by means of control electronics.
- c) The harmonic distortion of the speaker signals is limited.
- d) The multipath reception is amplified so that more stations can be received.



4. Which radio systems are equipped with the dual-tuner diversity system?

- a) R 100
- b) RCD 200
- c) RCD 300
- d) RCD500

5. Which statement about the Volkswagen Golf 2005 is correct?

- a) There are always two connecting wires for the aerials in the rear windscreen.
- b) Connecting wires are provided for the aerials depending on the equipment version ordered.
- c) Customer service always supplies a rear windscreen with two connecting wires as a replacement part.
- d) The connecting wires for the aerials can be retrofitted with retrofit kit 1H0 925 738.

6. Which statement about the Volkswagen Passat 2006 is correct?

- a) The mountings for the GPS and GSM aerial modules are have an electrical connection to the rear window.
- b) The mountings for the GPS and GSM aerial modules are have electrically isolated from the rear window.
- c) Only one version of the rear windscreen is installed.
- d) The rear windscreen depends on the equipment ordered.

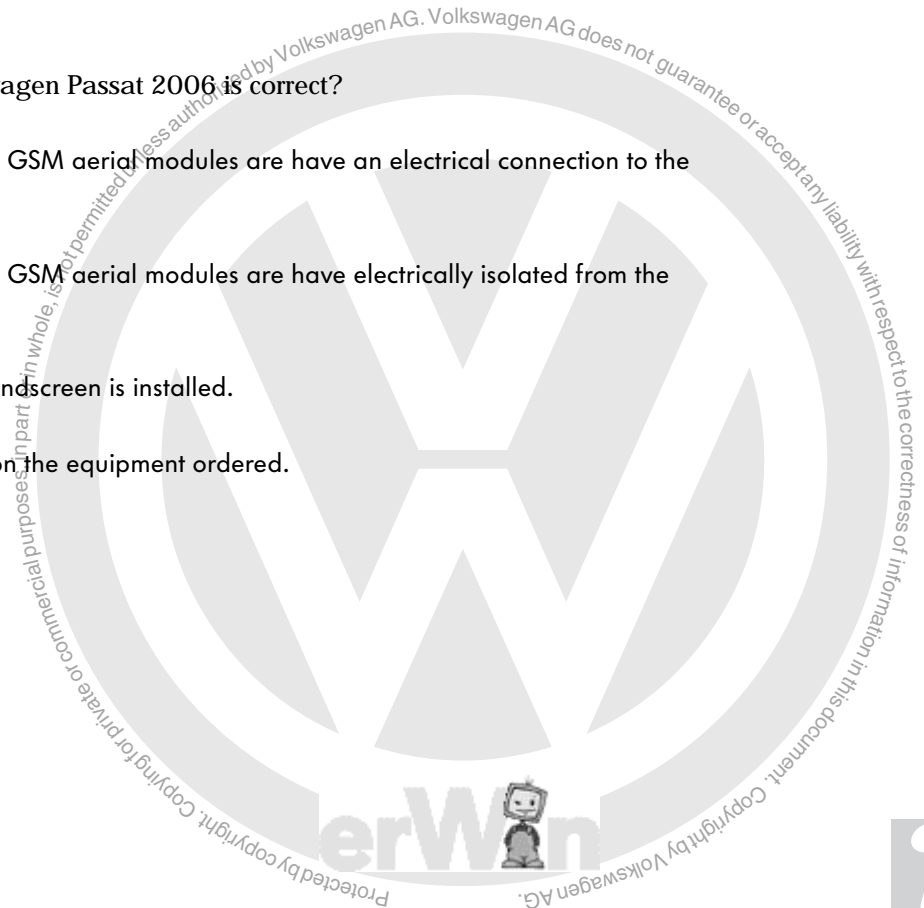

Answers: 1 b; 2 d; 3 a; 4 c; d; 5 b, c; 6 b, d



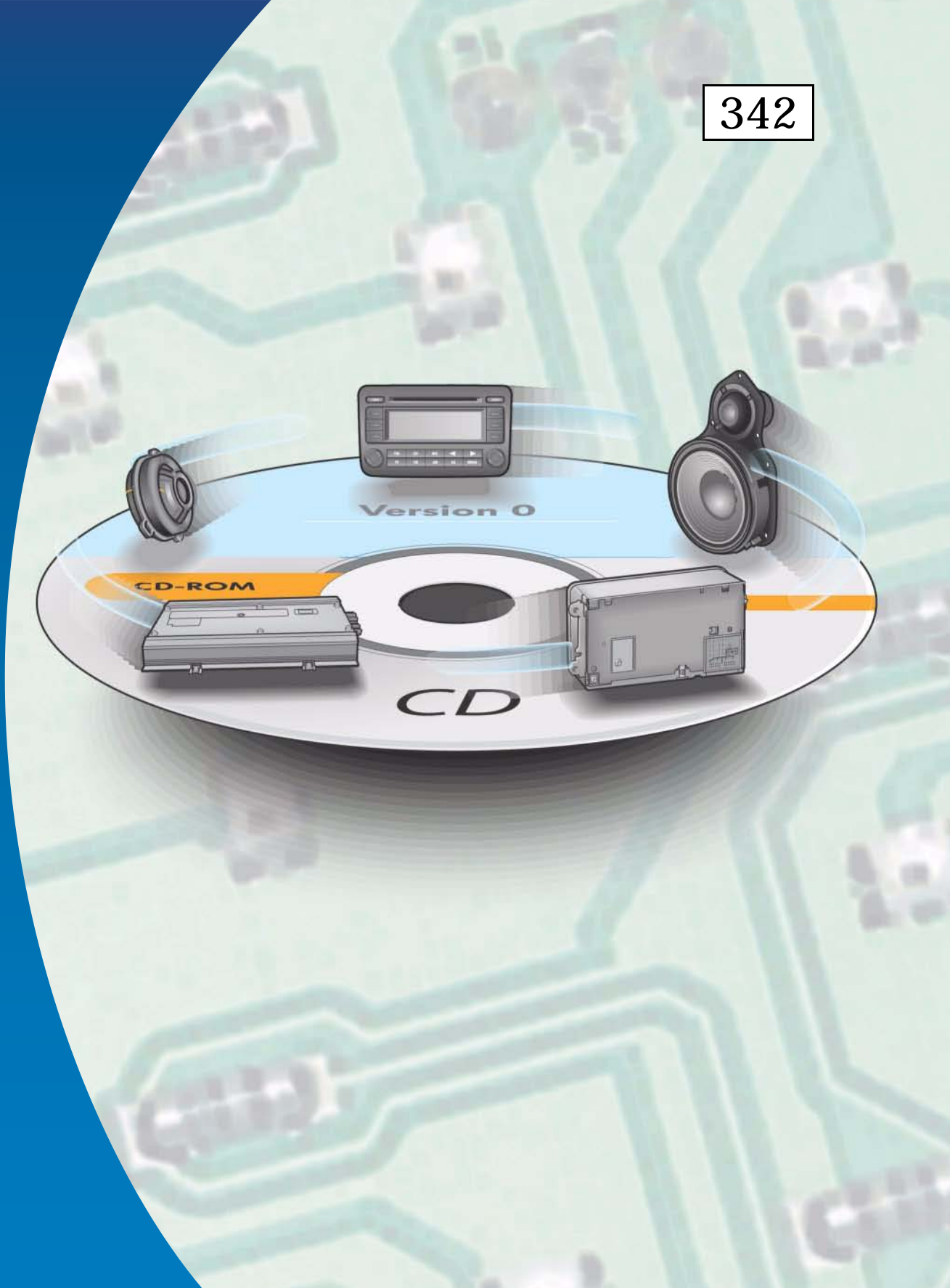

© VOLKSWAGEN AG, Wolfsburg
All rights and rights to make technical alterations reserved.
000.2811.57.20 Technical status 07.2005

Volkswagen
Service Training VK-21
Brieffach 1995
38436 Wolfsburg

♻️ This paper was manufactured from pulp that was bleached without the use of chlorine.