

Service Training



Self-study programme 339

The Passat 2006



The Passat – the unique comfort experience



S339_002

The Passat will continue its success story spanning over 30 years with the 2006 model. It will thrill customers by offering a new level of comfort in the upper mid-size class. This is achieved by the fact that the Passat 2006 already meets luxury class quality, safety and design standards. It continues to offer the economy traditional in the mid-size class. The drive concept fitted in the Passat 2006 has been redesigned to achieve these outstanding characteristics. The engine is mounted in the classic transverse configuration.

Passat model year 2006 product characteristics:

- All-encompassing comfort
- Characteristic design and product aesthetics
- Excellent quality
- Uncompromising safety
- Generous amount of space and variability
- High level of economy



Separate self-study programmes are available on the following topics:

- SSP 340 The Passat 2006 - electrical system
- SSP 346 The electromechanical parking brake
- SSP 347 Tyre pressure monitor systems

NEW



Attention Note



The self-study programme portrays the design and function of new developments! The contents will not be updated.

For current testing, adjustment and repair instructions, please refer to the customer service literature intended for this purpose.



In brief	4
Body	10
Occupant protection	20
Engines	24
Power transmission	41
Running gear	46
Electrical system	60
Heater and air conditioner	66
Radio and navigation	72

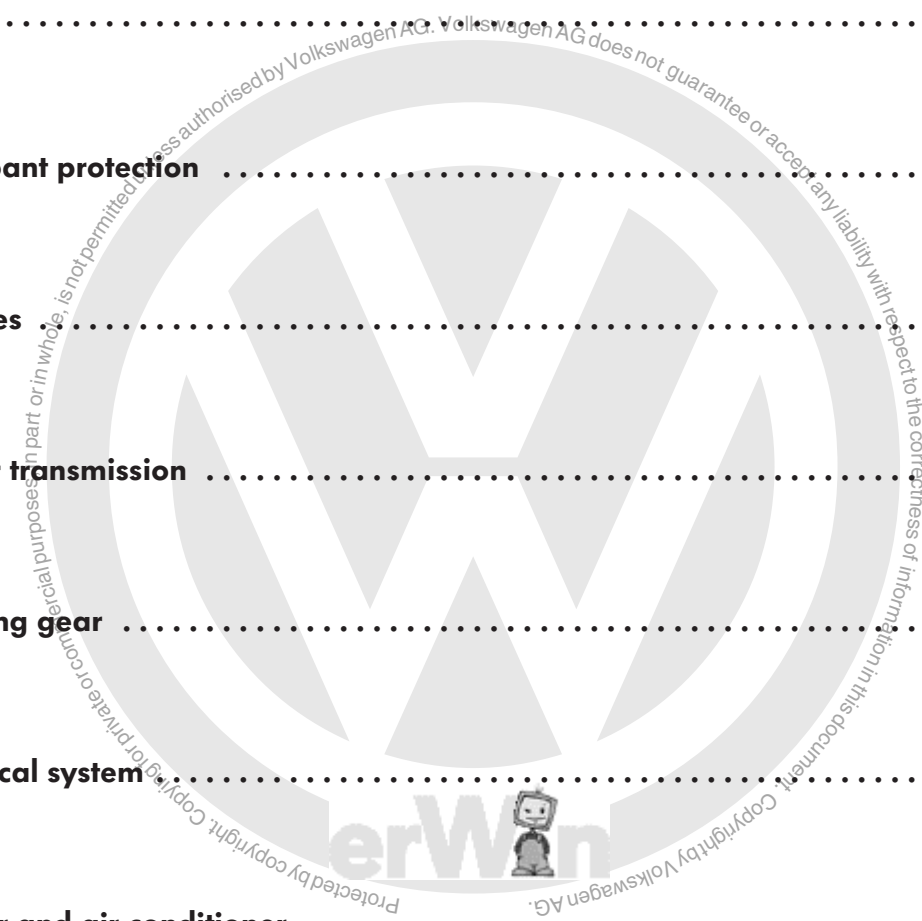

In brief



The Passat model year 2006

Where will the new Passat 2006 be built?

Like its predecessor, the new Passat will also be built in the Emden and Zwickau plants.



VW's Emden plant

The Emden plant, in which the majority of the Passat model vehicles will be built, was the first automobile production plant to be certified in Europe in September 1995. Up to December 2004, some 5.1 million Passats had been produced in the Emden plant.



S339_098



S339_003

Emden



Zwickau

S339_011

VW's Zwickau/Mosel plant

In Zwickau/Mosel, around 1150 Golfs and Passats are manufactured each day, in both left and right-hand drive versions, for all markets from Japan to North America. In January 2003, the one millionth Passat rolled off the assembly line in Zwickau/Mosel.



S339_005



In brief



The Passat 2006

The Passat 2006 will point the way forward in many disciplines, e.g.

- Design
- Vehicle dynamics
- Drive technology
- Spatial availability
- Safety
- Quality

- Dual-zone Climatronic

- Light assist

- Transversely mounted engine

- Bluetooth premium mobile phone pre-installation

- Cornering light system with bi-xenon

- Adaptive Cruise Control

- Comfortable key concept

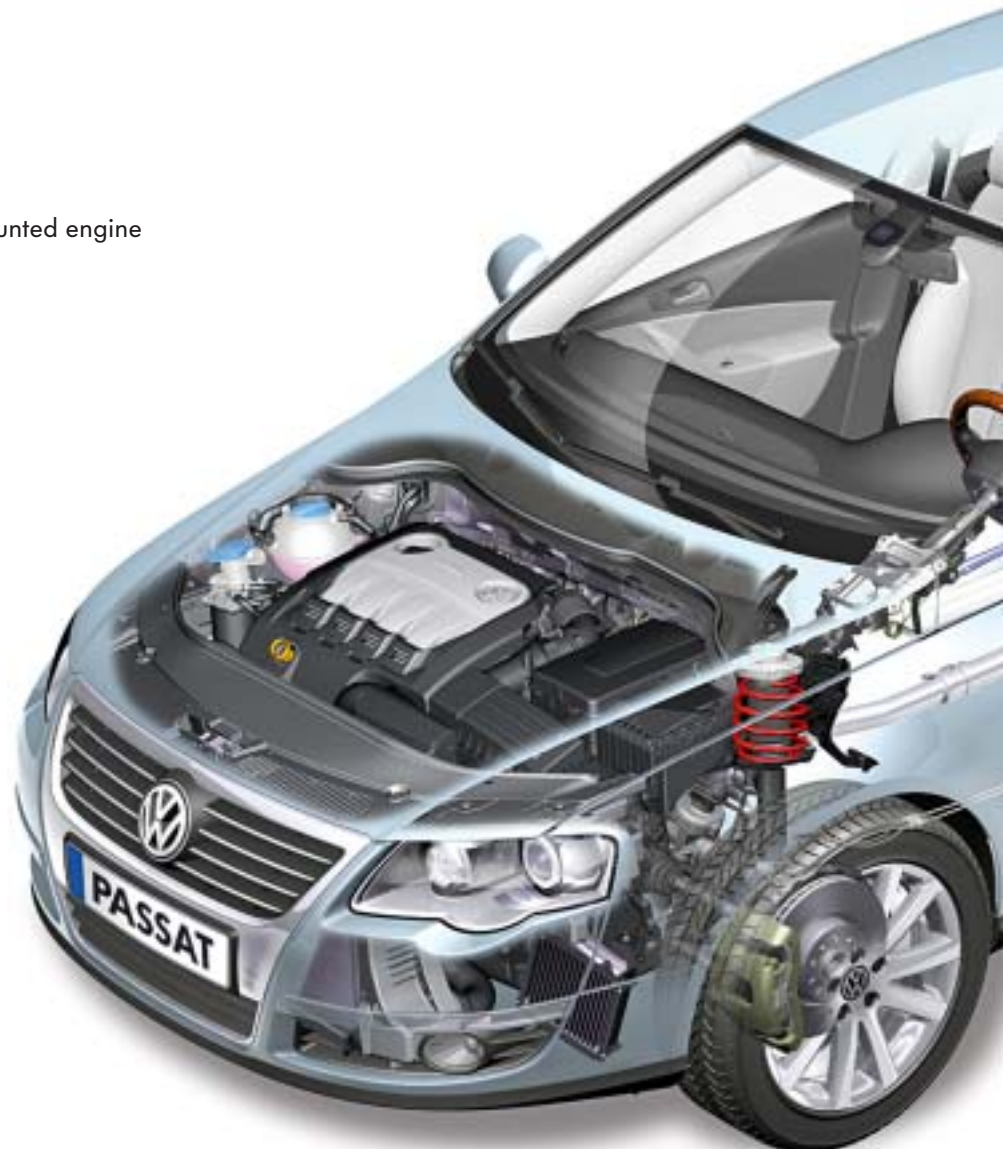



- High-end sound system

- Boot lid easy opening

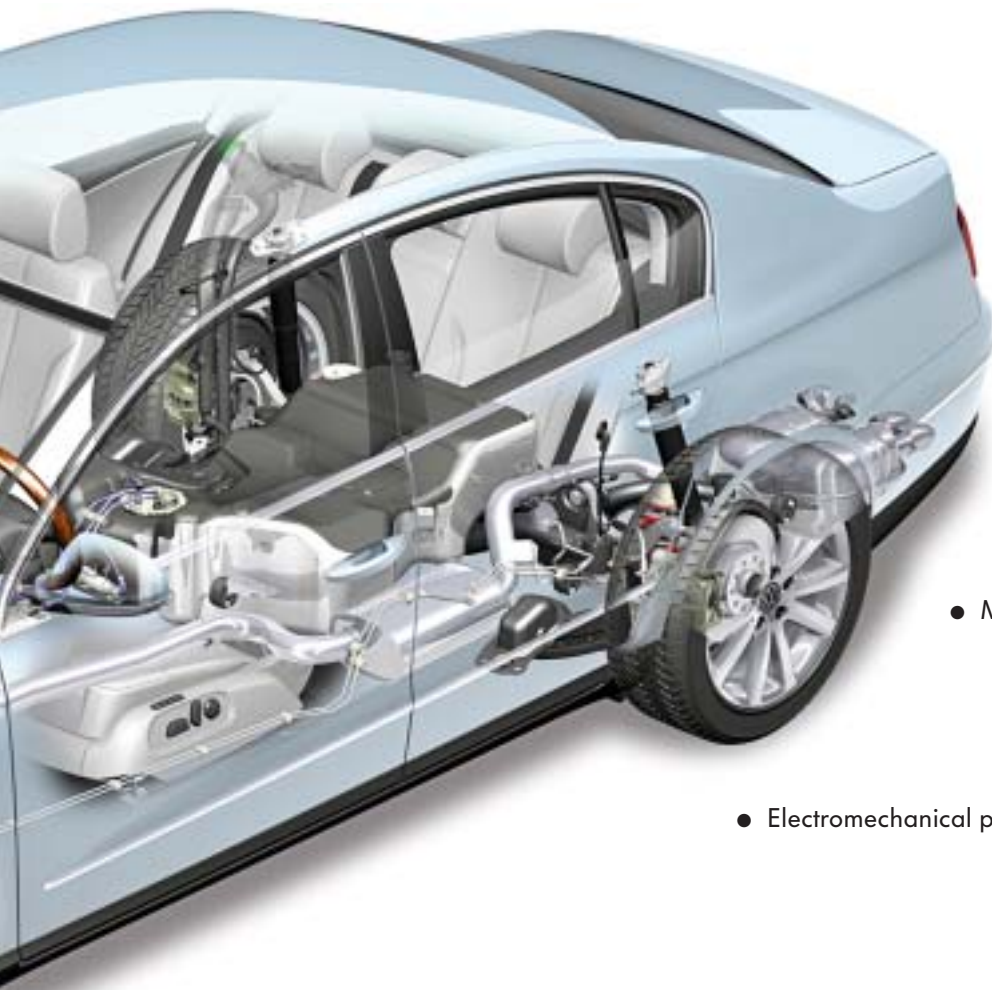

- Rear lights with LED technology

n AG does not guarantee or accept any liability with respect to the correctness of information in this document. Copyright by Volkswagen AG

S339_006

- Multi-link rear suspension

- Electromechanical parking brake

- Tyre pressure monitor systems

- 230V socket

In brief



Technical data

Passat saloon 2006



S339_007

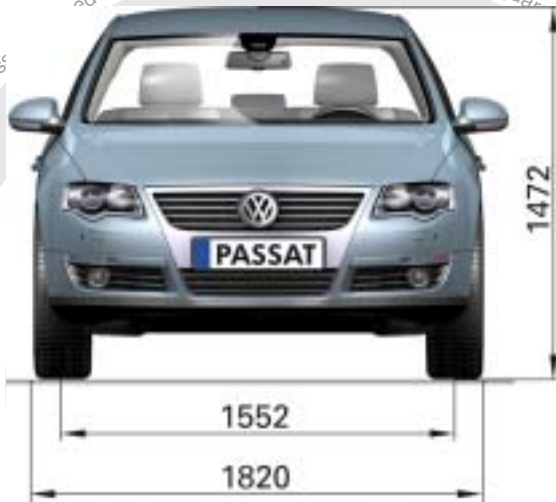

S339_008



S339_009

Length	4765 mm
Width	1820 mm
Height	1472 mm
Wheelbase	2709 mm
Roof load	100 kg
Trailed load (braked)	1300 kg

Front track	1552 mm
Rear track	1551 mm
Permissible gross vehicle weight	1950 kg
Unladen weight without driver	1391 kg
Drag coefficient	0.281 c _d
Fuel tank capacity	70 litres

Interior dimensions

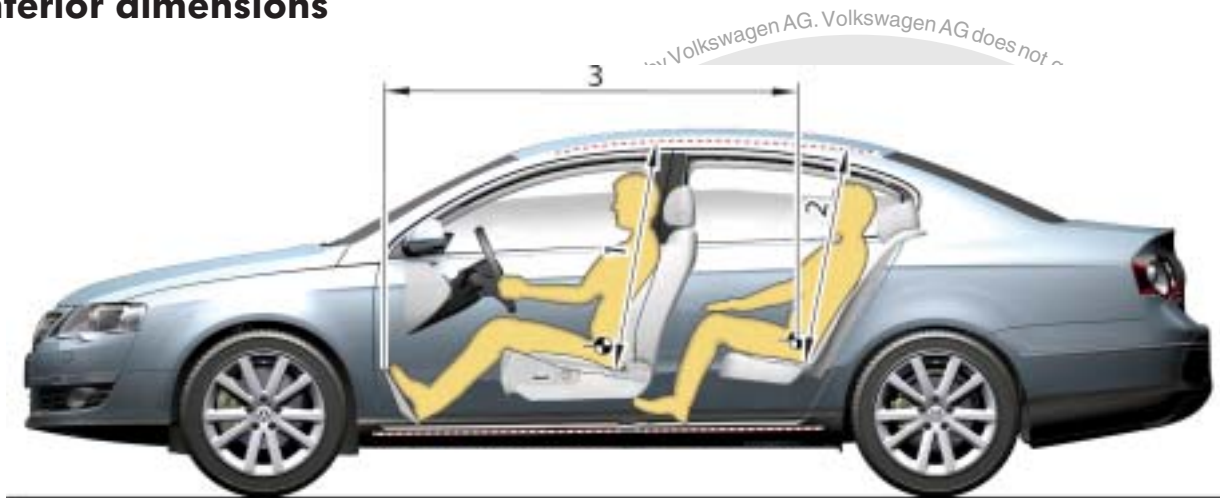

S339_010

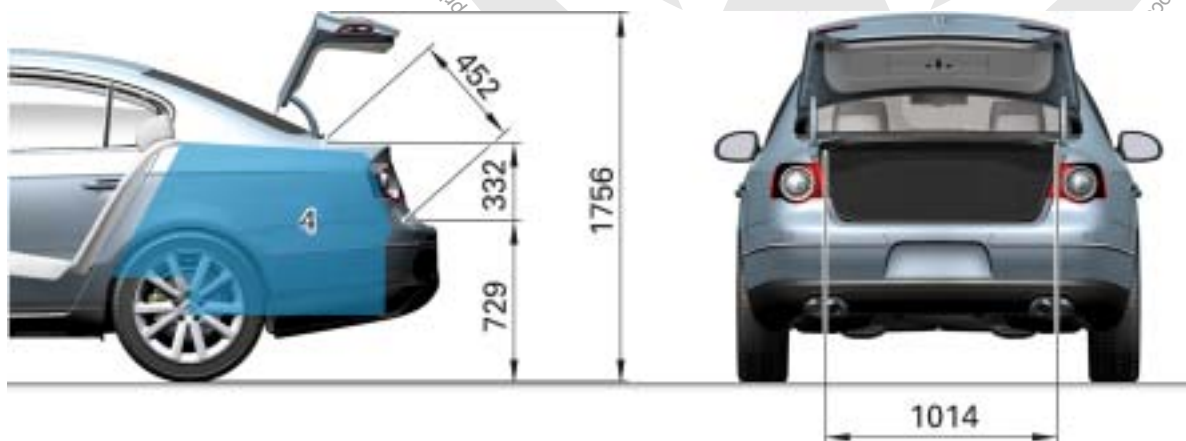

S339_012

1	Headroom, front	973 mm
2	Headroom, rear	961 mm
3	Interior length	1797 mm
4	Luggage compartment volume	565 litres*

* Including 80 litres in the spare wheel recess storage space



Body

The body structure

The new Passat's body has been optimised in terms of the following focal points:

- Passive safety
- Lightweight design
- Comfort
- Pedestrian protection

This has been achieved by using high- and ultra-high-strength steel panels and ultra-high-strength, hot-formed steel panels.

The steel panel thicknesses have additionally been optimised for the relevant stresses.

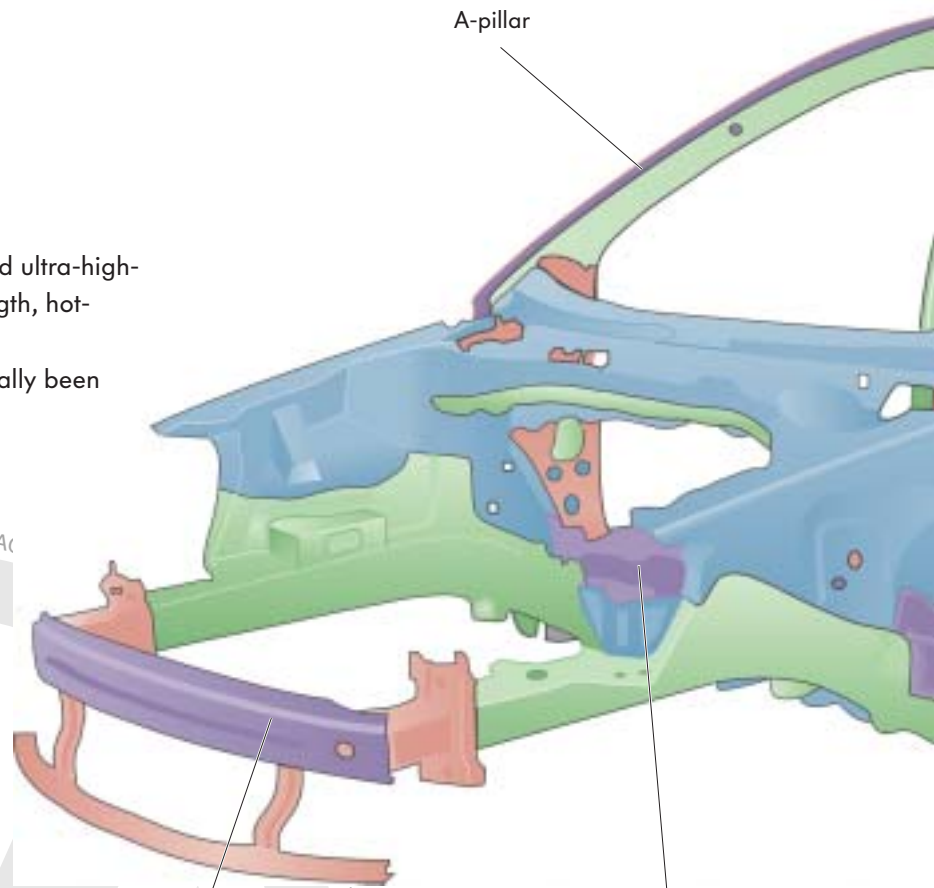

The following assemblies are manufactured from ultra-high-strength steel panels:

- The inner A-pillar
- The seat brackets
- The outer sills
- The rear longitudinal members

The following assemblies are manufactured from ultra-high-strength, hot-formed steel panels:

- The front bumper cross member
- The cross members in the footwell area
- Inner sills
- The centre tunnel
- The A-pillar/roof frame area
- The B-pillar

Front bumper cross member

Cross members in the footwell area



Centre tunnel

S339_152

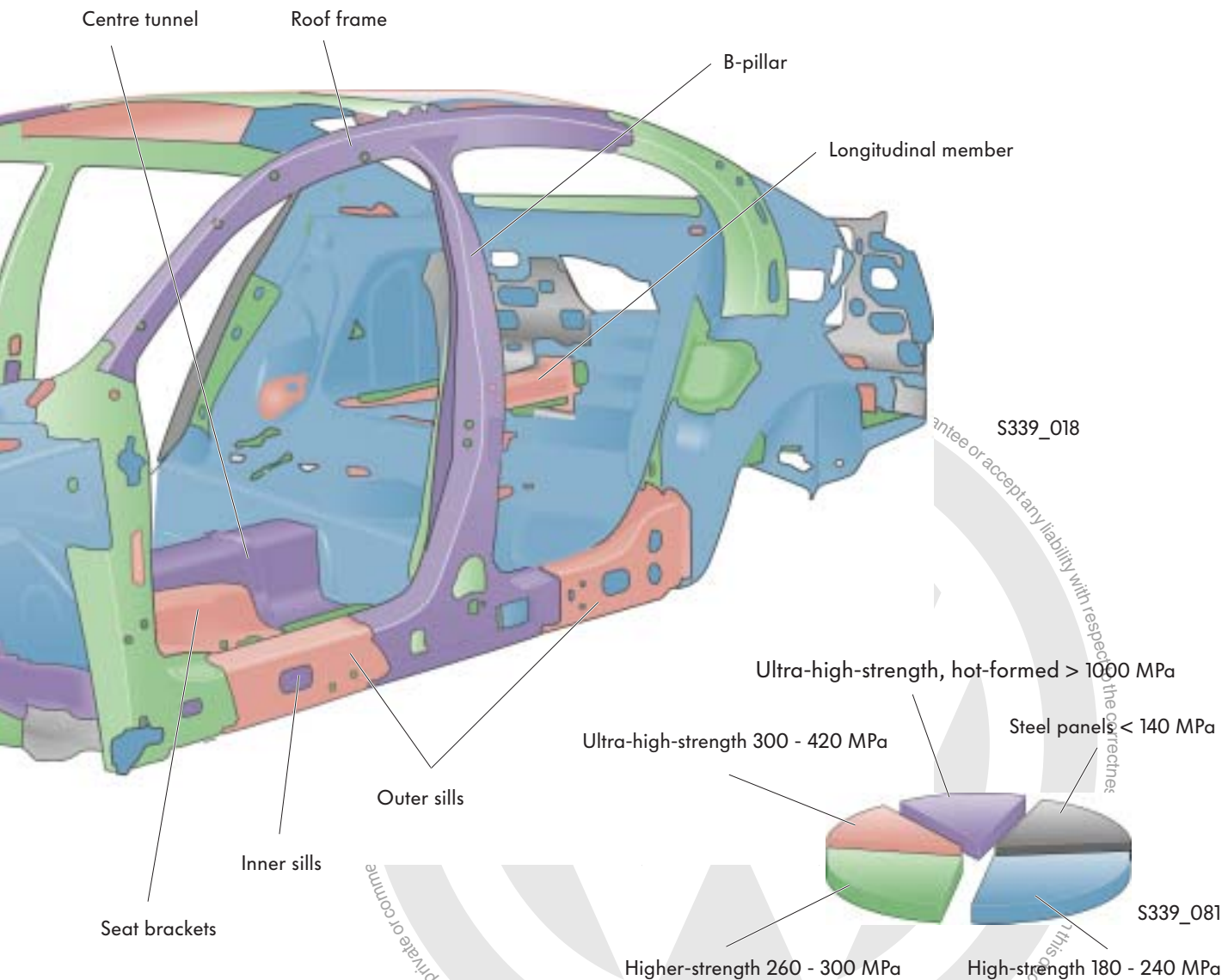

What are ultra-high-strength, hot-formed steel panels?

These are steel panels which, as the name implies, are formed when hot at temperatures of between 900 °C and 950 °C.

The steel panels are provided with their high strength thanks to a specific cooling process in the forming die. They are form-hardened.

The use of ultra-high-strength, hot-formed steel panels has enabled the body weight to be lowered by approx. 20 kg without reducing the strength.

Yield strengths of the steel panels which are used:

- Steel panels up to 140 MPa
- High-strength steel panels from 180 to 240 MPa
- Higher-strength steel panels from 260 to 300 MPa
- Ultra-high-strength steel panels from 300 to 420 MPa
- Ultra-high-strength, hot-formed steel panels over 1000 MPa

$$1 \text{ MPa} = 1 \text{ Newton/mm}^2$$

Body

The joining techniques

Thanks to the use of laser welded and soldered joints and spot welded/bonded joints, the body structure is safeguarded in the event of a crash.

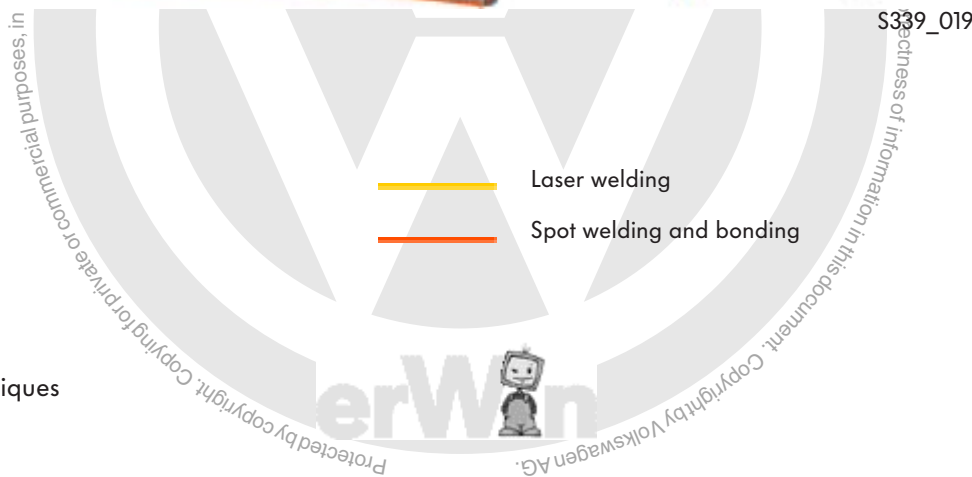

The following joining techniques are employed:

Laser welds

- in the area of the door apertures
- on the front and rear roof member
- on the lateral windscreen frame
- in the area of the front wheel housing
- in the area of the lower rear window frame
- on the rear cross panel

Spot weld bonds

- in the area of the longitudinal member to the floor panel
- in the area of the lower sill
- in the area of the rear wheel housing

Laser soldered joints

- in the roof skin
- side panel/luggage compartment sealing duct

The flow of force in a frontal crash

In the event of a frontal crash, the forces which occur are guided into the floor panel and the roof longitudinal members via the upper and lower longitudinal members.



Side view

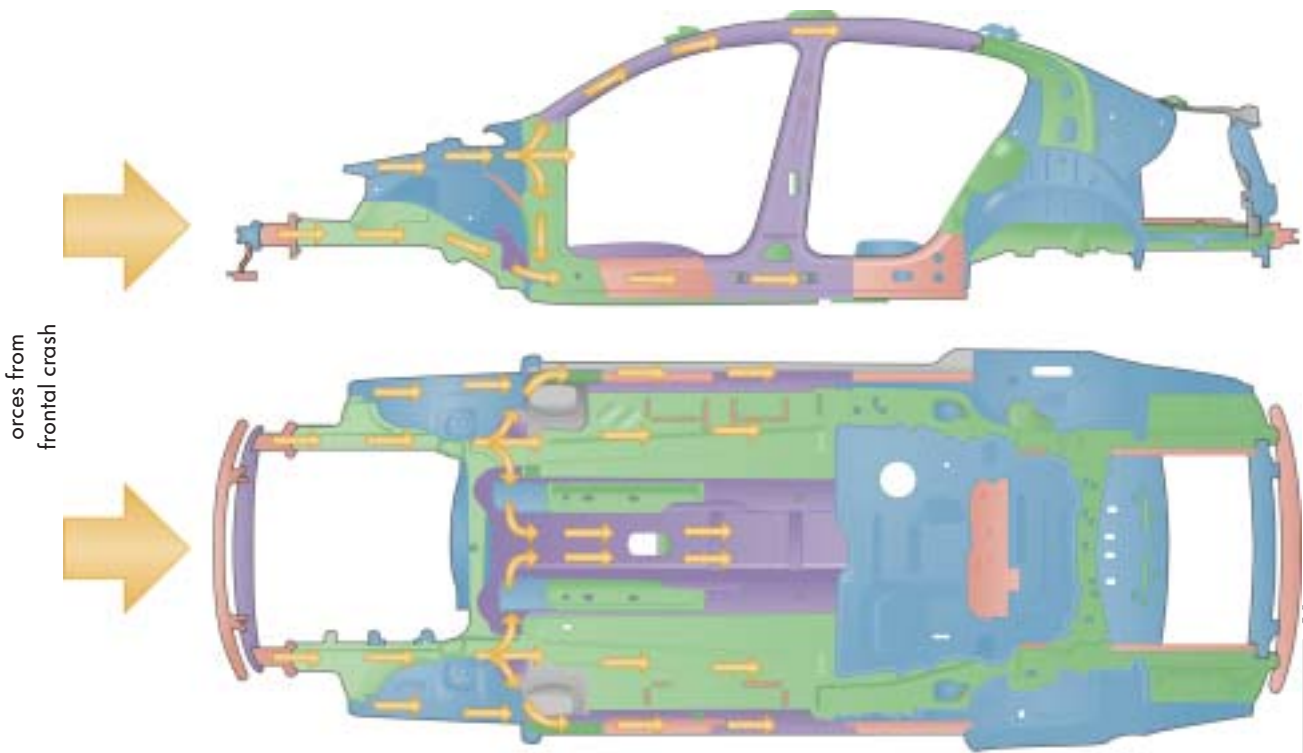

View from below

S339_020

In the event of a lateral crash, the passenger survival space is ensured by means of a triple-shell side wall. This is supported on the underlying body structure.

The side wall's main component is the B-pillar, comprised of hot-formed steel panels.

In the floor panel, the B-pillar is supported on the ultra-high-strength steel seat bracket. In the roof, it is supported on the high-strength steel roof cross member.



The body colours correspond to the assignment of the steel panel grades from the body structure depiction.

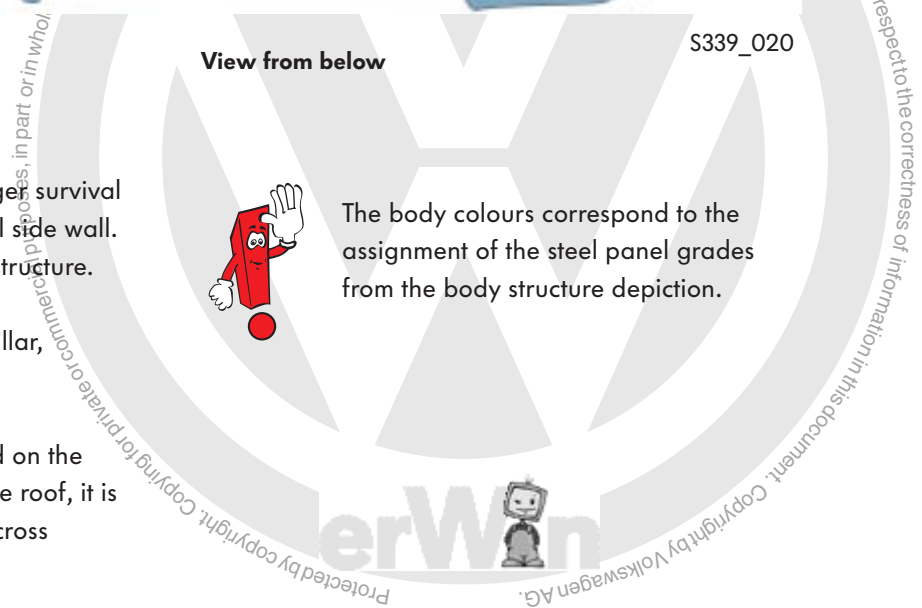

Protected by copyright. Copying for private or commercial purposes, in part or in whole, is prohibited. Copyright by Volkswagen AG.

Body

The seats

The front seats



Seat guidance and adjustment are carried out via parallel seat rails. This results in finer adjustment in comparison with the predecessor's central adjustment rail.

Mechanical 2-way and electric 4-way lumbar support adjustment are optionally available.

All seat variants are fitted with the familiar Active Head Restraint System AKS.

A seat with a massage function in the backrest is available as an additional option.

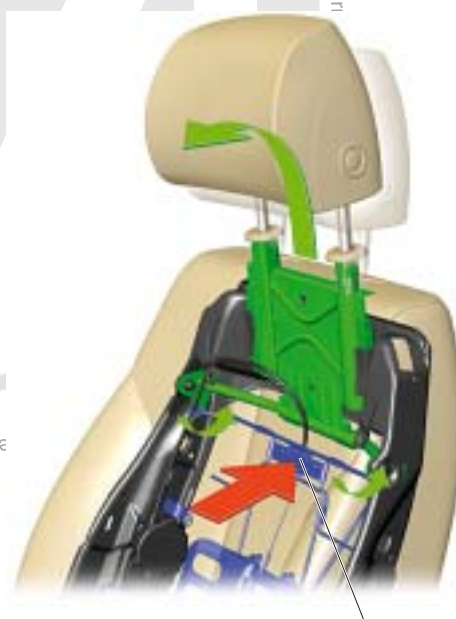

Head restraint adjustment is carried out via an integrated actuation mechanism.

The front passenger seat with through-loading function

With this optional seat, the seat backrest can be folded horizontally forwards by actuating the release lever.

This enables the vehicle's entire passenger compartment length to be used as transportation space.

Front passenger seat in through-loading position



The seat occupied recognition system

The front passenger seat is fitted with a seat occupied recognition sensor. This is located under the seat cover on the padded cushion.

If the sensor reports that the front passenger seat is occupied and the belt buckle simultaneously outputs a signal that the buckle tab is not inserted, the front passenger is optically and acoustically requested to don his seat belt.



Body

The rear seats

The rear seat bench is split 1/3 to 2/3.
The seat backrests can be individually folded.



S339_026

The backrest locking mechanism

The backrests are locked by means of a rotary latch lock.
If the backrest is not locked, this is displayed via a red indicator.

Protected by copyright. Copyright by Volkswagen

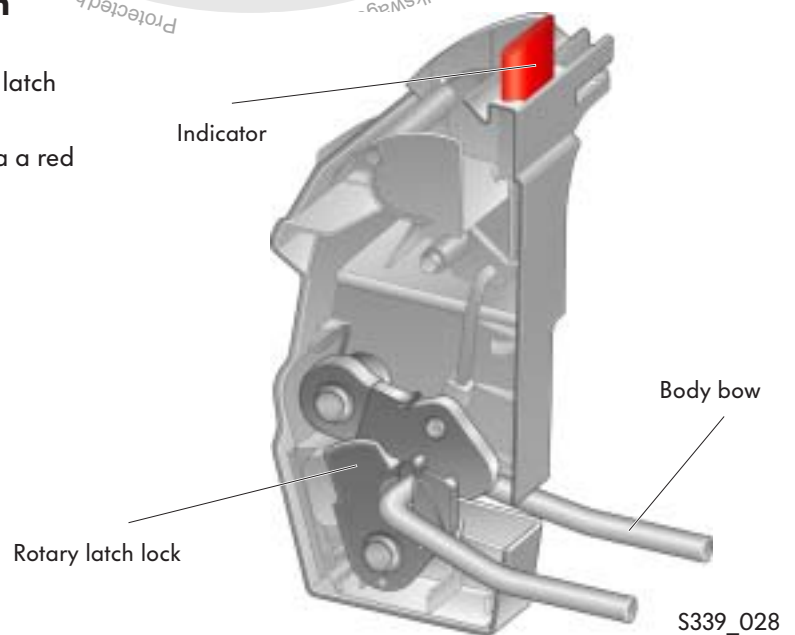

S339_028

The integrated child seats

A rear seat bench with two integrated child seats is optionally available.

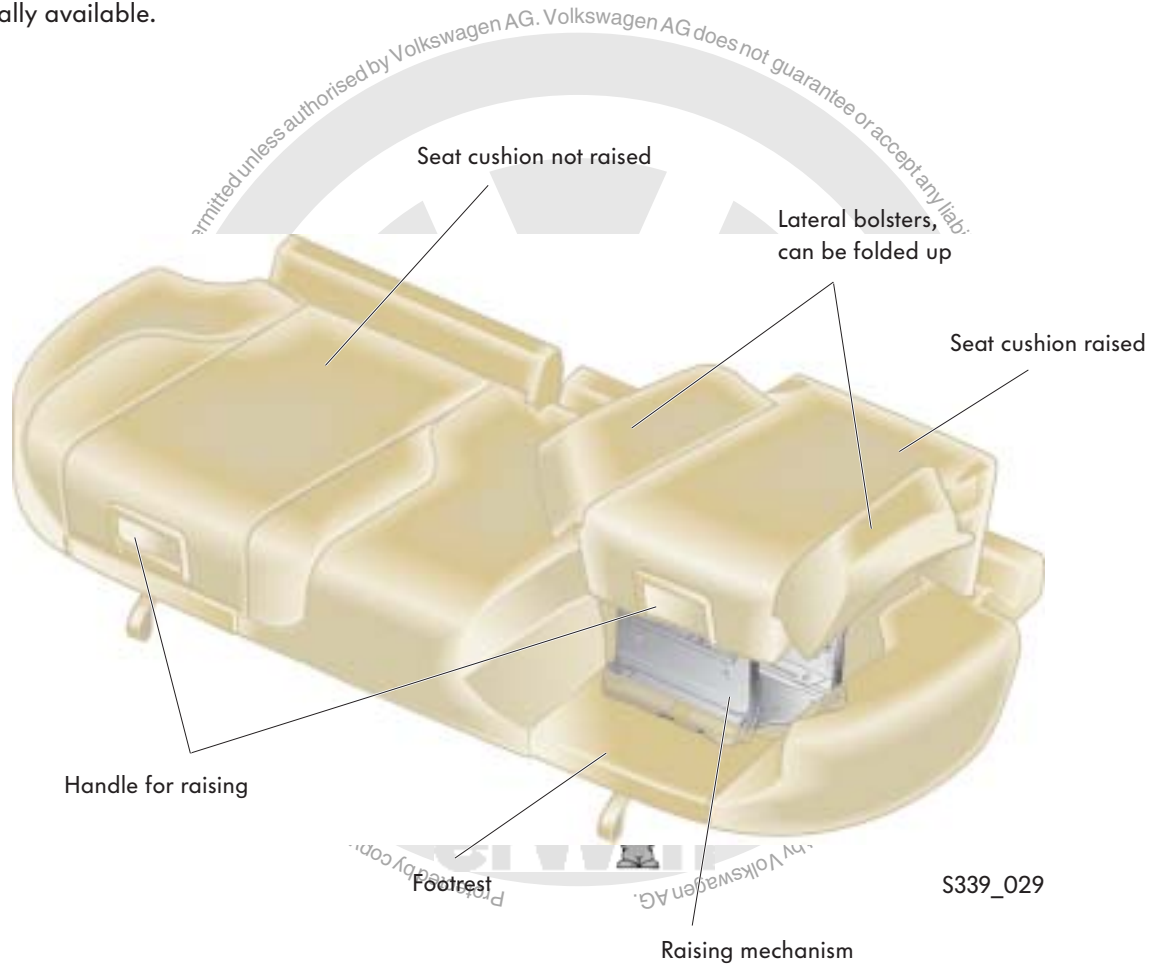

The seat cushions on the outer seats can be raised.

This serves to raise the seat for small children.

After raising the seat cushion, the lateral bolsters have to be raised manually. On folding down, these automatically return to their original position.



The rear window roller blind

The rear window roller blind is available as either a mechanical or an electric version.

- In the mechanical variant, the roller blind is pulled up via a handle and is locked in this position.
- The electric variant is actuated using a button in the centre console.



S339_038

The electric rear window roller blind

How it works:

The rear window roller blind guides are located in the C-pillars. After pressing the button, a drive motor pushes a sliding block located in each guide upwards via two Bowden cables. The rear window roller blind is secured to these sliding blocks.



S339_031

In its upper terminal position, the drive motor is deactivated via an electronic force limiter. This prevents body parts from becoming trapped between the rear window roller blind and the surrounding trim components.

Pressing the button again causes the rear window roller blind to retract into the rear shelf. It is integrated flush into the rear shelf.

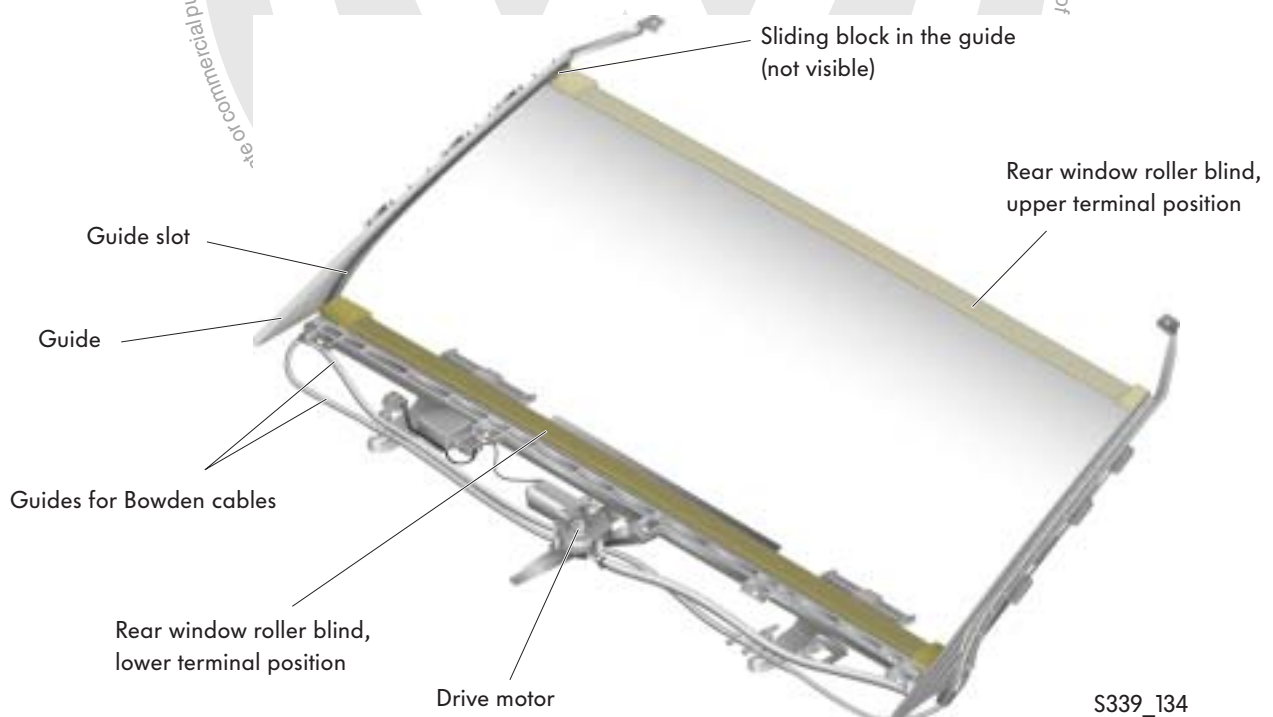

S339_134



Occupant protection

Introduction

The Passat is equipped with the following airbags:

- Two-stage driver and front passenger airbags
- Head airbags
- Side airbags (optional in the rear)

The outer seats are fitted with seat belts with belt tension limiters.

Front seat belt pre-tensioners are fitted as standard. Seat belt pre-tensioners are optionally available for the outer rear seats.



The two-stage airbags

The new Passat is equipped with two-stage airbags on the driver and front passenger side; these inflate to different levels according to the accident severity. Together with the installation position selected for the front passenger airbag, in the upper part of the dash panel, optimal occupant restraint is achieved with minimal risk of injury in the event of a frontal crash thanks to the airbags' activation.

The Passat's airbag activation system is comprised of an airbag control unit secured in the front area of the frame tunnel; this is equipped with three internal acceleration sensors (two sensors in the vehicle longitudinal direction and one in the vehicle transverse direction), an early crash sensor in the area of the bonnet lock for supporting front crash detection and 4 sensors for lateral crash detection.

Two sensors are designed as pressure sensors and are located in both front doors. During a lateral collision, these sensors measure the rise in air pressure caused by front door deformation.

Early crash sensor

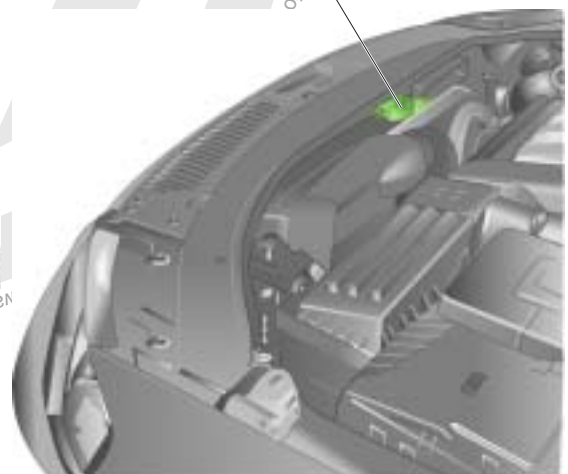

S339_120



Belt buckles with belt buckle interrogation are fitted on the driver and front passenger side. The front passenger seat is additionally equipped with seat occupied recognition, which is carried out via a sensor on the seat padding.

Belt buckle interrogation and seat occupied recognition serve as a seat belt prompt system.



The front passenger airbag can be deactivated via a key switch in the glove box.

S339_034

In the event of collisions which directly damage the front doors, this sensor concept is significantly faster and more robust than conventional measurement of the vehicle's lateral acceleration. In addition, two acceleration sensors are also installed in the lower area of the C-pillar to detect lateral collisions, which do not deform the front doors, in good time.

In the event of lateral collisions which exclusively affect the front of the vehicle, the vehicle lateral acceleration measured in the airbag control unit is used for crash detection purposes. Rear crash detection is carried out using the two vehicle longitudinal acceleration sensors in the airbag control unit.

Occupant protection

The two-stage airbags

Two separate igniter circuits and charges are fitted within the two-stage airbags. Both stages are always deployed in the event of an accident.

However, the deployment times are staggered depending on the accident severity.

In a minor accident, the time between deployment of the two stages is greater than in the event of a severe accident.

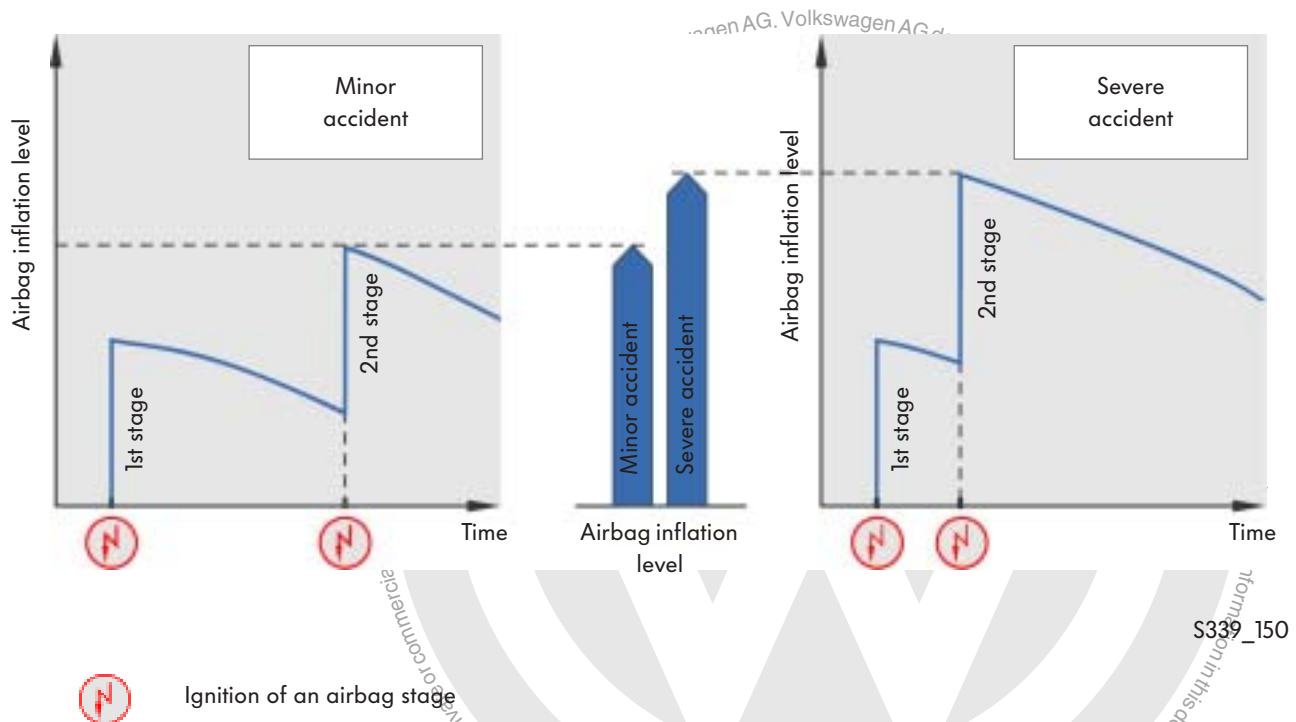

The time gap between the deployment of both stages influences the airbag's inflation level:

If the second stage is deployed later, the airbag's pressure from initial deployment has already dissipated somewhat, and the airbag inflation level is relatively low.

If both stages are deployed shortly after each other, the airbag's pressure from initial deployment has not yet been dissipated, and the airbag becomes harder.

The seat belt pre-tensioners

The outer, rear seats in the Passat 2006 are fitted with a new type of seat belt pre-tensioner.

Structure:

The belt strap is guided through the deflector in the lower area of the C-pillar. It is held by a cable which leads into the seat belt pre-tensioner. The cable is firmly anchored in the seat belt pre-tensioner.





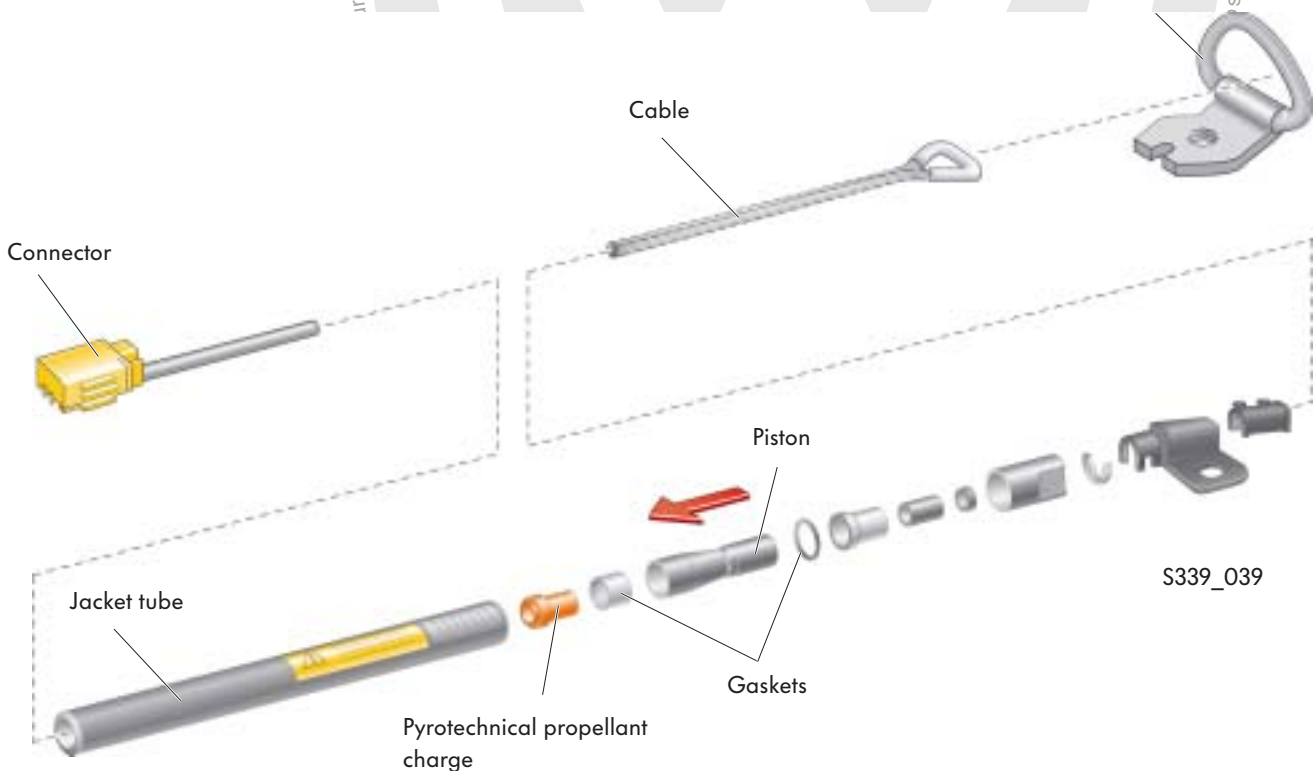
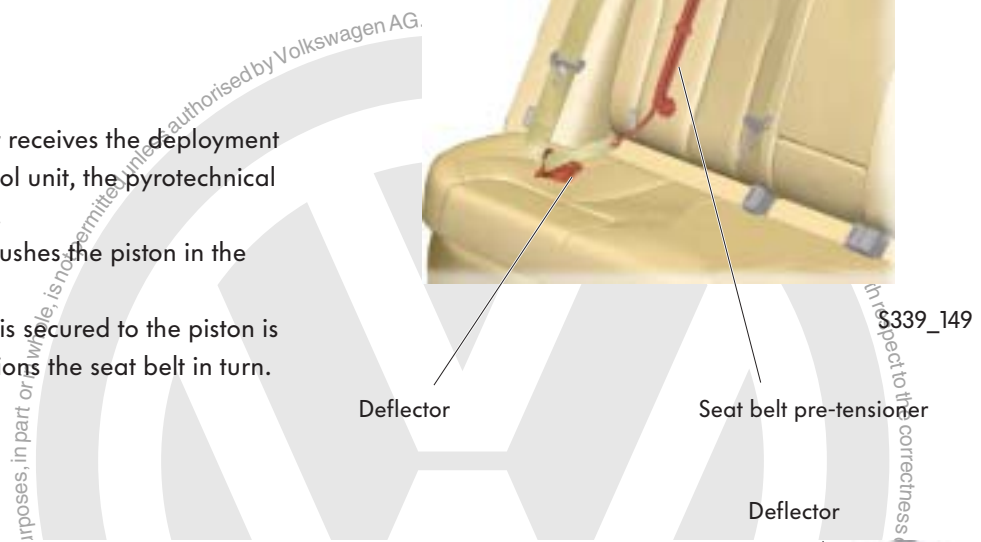



How it works:











If the seat belt pre-tensioner receives the deployment signal from the airbag control unit, the pyrotechnical propellant charge is ignited. The force which is built up pushes the piston in the direction of the arrow. As a result, the cable which is secured to the piston is carried along and now tensions the seat belt in turn.

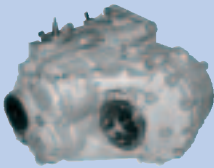

Engines

Engine-gearbox combinations

Petrol engine		5-speed manual gearbox 0AH	5-speed manual gearbox 0A4
Diesel engine			
	1.6l/75 kW Petrol engine BSE		
	1.6l/85 kW FSI engine BLF		
	2.0l/110 kW FSI engine BLR		
	2.0l/147 kW FSI engine (turbocharged engine) AXX		
	1.9l/77 kW TDI engine BKC		
	2.0l/103 kW 4V TDI engine BKP		
	2.0l/103 kW 2V TDI engine with diesel particulate filter BMP		

6-speed manual gearbox 0AJ	6-speed manual gearbox 02S	6-speed manual gearbox 02Q	Direct-Shift Gearbox 02E	6-speed automatic gearbox 09G
				
				
				
				
				



Engines

The 1.6l/75 kW engine with 2-valve technology

The 1.6l/75 kW engine is based on the familiar 1.6 l/ 75 kW engine with the engine code BGU, which is fitted in the Golf 2004.

Special technical features

- 2-valve roller rocker fingers
- aluminium engine block with ribbed oil pan
- secondary air system
- plastic variable intake manifold
- pressure sensor-controlled system, previously hot film air mass sensor (HFM)
- omission of the crankcase breather, ventilation via the cylinder head only
- omission of the exhaust gas recirculation system



S339_040

Technical data

Engine code	BSE
Design type	4-cylinder in-line engine
Displacement	1595 cm ³
Bore	81 mm
Stroke	77.4 mm
Valves per cylinder	2
Compression ratio	10.3 : 1
Max. output	75 kW at 5600 rpm
Max. torque	148 Nm at 3800 rpm
Engine management system	Simos 7.2
Fuel	Super unleaded RON 95 (Normal unleaded RON 91 with slight reduction in output)
Exhaust gas aftertreatment	Primary catalytic converter probe: linear lambda probe, secondary catalytic converter probe: transient probe
Exhaust emission standard	EU 4

Torque and output graph

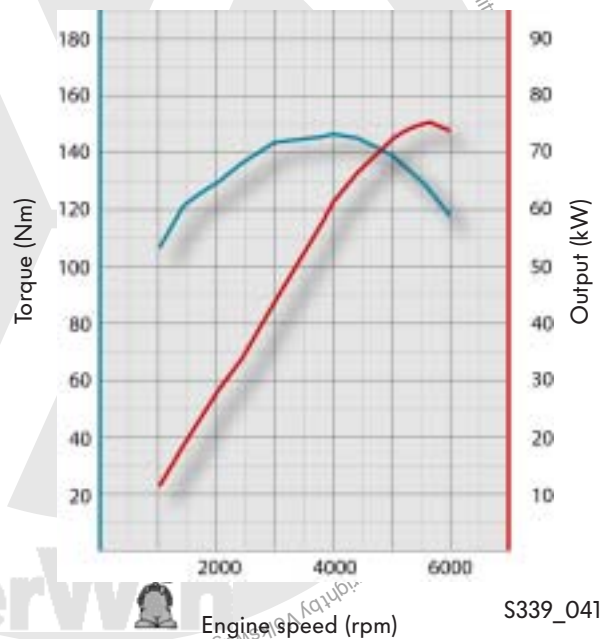

S339_041

The 1.6l/85 kW FSI engine

This engine originates from the Golf 2004. It differs from this only due to its switch to lambda 1 operation and super unleaded RON 95.

Special technical features

Stratified charge and homogeneous lean operation have been omitted due to the switch to lambda 1 (homogeneous operation). This leads to the occurrence of less nitrogen oxide, and the omission of complex trapping and regeneration of this.

This leads to the following changes:

- The exhaust gas temperature sender has been omitted
- instead of the NO_x storage reduction catalytic converter, a three-way catalytic converter has been installed
- instead of the NO_x sender, a transient lambda probe has been installed.

Technical data

Engine code	BLF
Design type	4-cylinder in-line engine
Displacement	1598 cm ³
Bore	76.5 mm
Stroke	86.9 mm
Valves per cylinder	4
Compression ratio	12 : 1
Max. output	85 kW at 6000 rpm
Max. torque	155 Nm at 4000 rpm
Engine management system	Bosch Motronic MED 9.5.10
Fuel	Super unleaded with RON 95 (super plus RON 98 leads to an increase in torque in the medium engine speed range)
Exhaust gas aftertreatment	Primary catalytic converter, main catalytic converter, lambda control
Exhaust emission standard	EU 4



S339_042

The switch from super plus RON 98 to super unleaded RON 95 is achieved via ignition angle adjustment.

Operation with RON 91 is not permitted, as ignition is retarded to the control limits in this case.

Torque and output graph

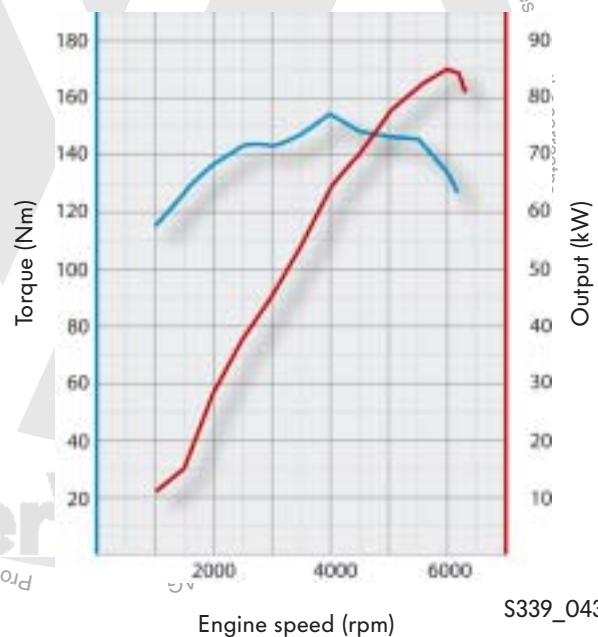

S339_043



Information on the fuel system can be found in self-study programme 334 "The FSI engine fuel system".



Engines

The 2.0l/110 kW FSI engine with 4-valve technology

The 2.0l/110 kW FSI engine dispenses with stratified charging and the NO_x sensor system. The abbreviation FSI will be retained.

Special technical features

- ethanol-resistant Hitachi high-pressure pump
- two overhead camshafts with continuous intake camshaft adjustment
- roller rocker fingers with hydraulic supporting element
- balancer shaft gear assembly
- plastic variable intake manifold with change-over barrel
- continuously variable tumble flaps
- water-cooled exhaust gas recirculation
- homogeneous fuel injection



S339_044



Further information on this engine can be found in SSP 322 "The 2.0l/110 kW engine with direct petrol injection".

Technical data

Engine code	BLR
Design type	4-cylinder in-line engine
Displacement	1984 cm ³
Bore	82.5 mm
Stroke	92.8 mm
Valves per cylinder	4
Compression ratio	11.5 : 1
Max. output	110 kW at 6000 rpm
Max. torque	200 Nm at 3500 rpm
Engine management system	Bosch Motronic MED 9.5.10
Fuel	Super plus unleaded RON 98 (Super unleaded RON 95 with slight reduction in output)
Exhaust gas aftertreatment	Two primary catalytic converters and one three-way catalytic converter with oxygen control
Exhaust emission standard	EU 4

Torque and output graph

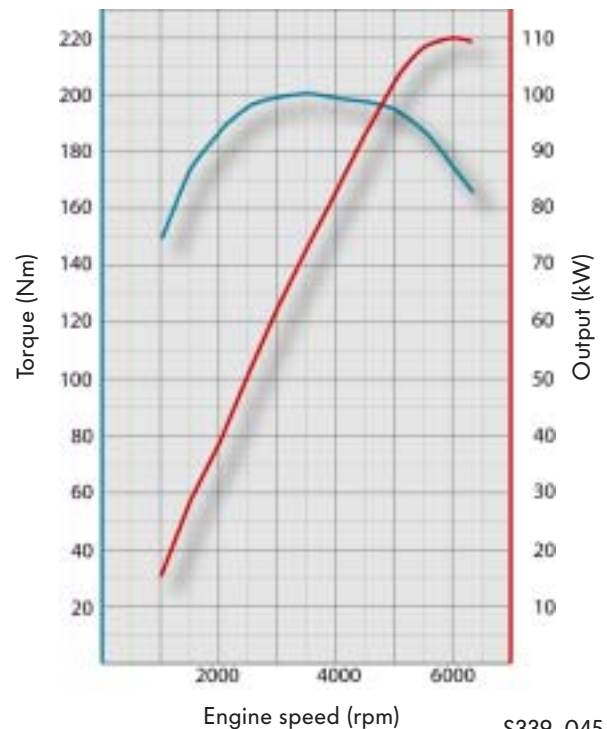

S339_045

The 2.0l/147 kW turbo FSI engine with 4-valve technology

A further developed turbo FSI engine is to follow on the basis of the 2.0l/110 kW engine.

The turbo FSI engine was first launched in 2004 in the Audi A3 Sportback and the Golf GTI.

Special technical features

- single-branch exhaust system with underhood primary and underfloor catalytic converter
- ethanol-resistant Hitachi high-pressure pump
- return-free fuel system
- homogeneous fuel injection
- decoupled drive sprocket in the balancer shaft gear assembly
- elliptical toothed belt sprocket on the crankshaft



S339_046



Further information on this engine can be found in SSP 337 "The 2.0l FSI engine with turbocharging".

Technical data

Engine code	AXX
Design type	4-cylinder in-line engine
Displacement	1984 cm ³
Bore	82.5 mm
Stroke	92.8 mm
Compression ratio	10.5 : 1
Max. output	147 kW at 5100-6600 rpm
Max. torque	280 Nm at 1800-4700 rpm
Engine management system	Bosch Motronic MED 9.1
Camshaft adjustment	42° crank angle
Fuel	Super-plus unleaded RON 98 (Super unleaded RON 95 with slight reduction in output)
Exhaust gas aftertreatment	Two three-way catalytic converters with oxygen control
Exhaust emission standard	EU 4

Torque and output graph

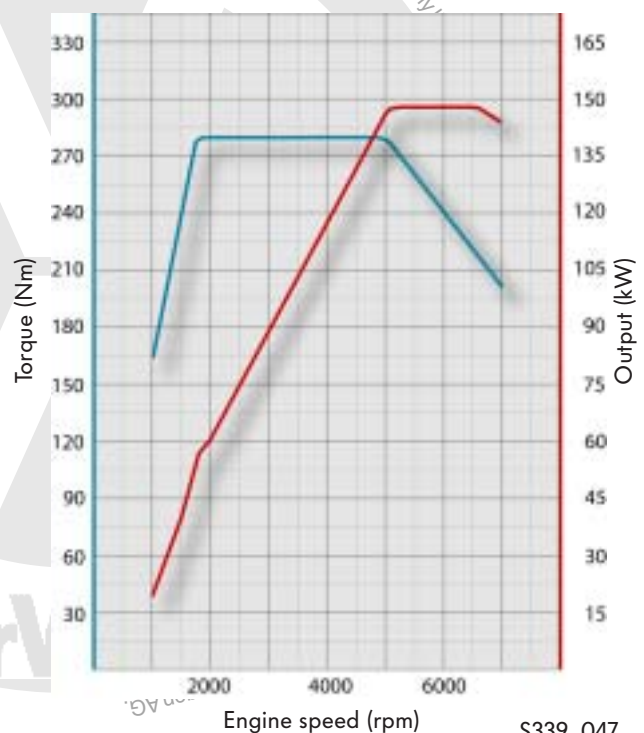

S339_047

Engines

The diesel engines

All of the diesel engines fitted in the new Passat comply with the EU4 exhaust emission legislation.

Optionally, vehicles with diesel engines can be equipped with a state-of-the-art particulate filter system.

This new system combines the oxidising catalytic converter and the particulate filter in one component, the catalytically coated diesel particulate filter.

Due to its underhood location, no fuel additive is required for soot combustion. In combination with a new engine oil, the diesel particulate filters are entirely maintenance-free.

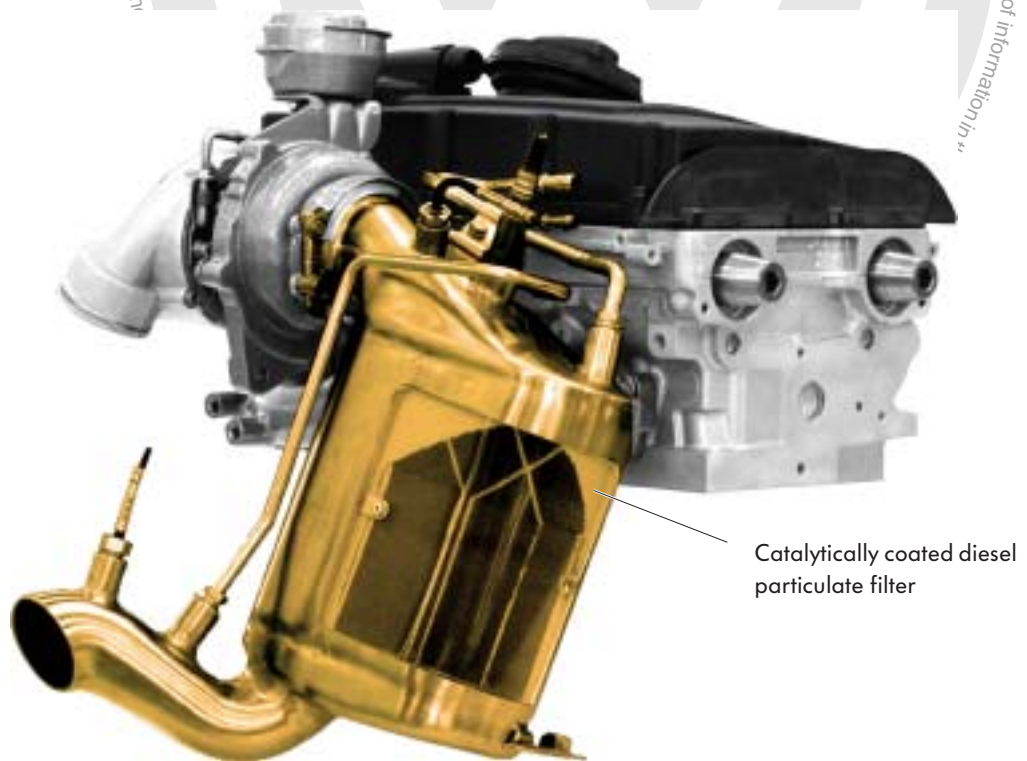

S339_146



Information on these diesel particulate filters can be found in self-study programme 336 "The catalytically coated diesel particulate filter".

The 1.9l/77 kW TDI engine with 2-valve technology

This tried-and-tested 1.9l/77 kW TDI engine is also installed in the current Golf model and in other Volkswagen models. For installation into the Passat, it has been modified and adapted to the new vehicle.

Special technical features

- switchable exhaust gas recirculation cooler
- crankshaft sealing flange with integrated sender wheel for engine speed
- accelerator pedal module with contact-free accelerator pedal position senders
- contact-free clutch pedal switch.



S339_048

Technical data

Engine code	BKC
Design type	4-cylinder in-line engine
Displacement	1896 cm ³
Bore	79.5 mm
Stroke	95.5 mm
Valves per cylinder	2
Compression ratio	19 : 1
Max. output	77 kW at 4000 rpm
Max. torque	250 Nm at 1900 rpm
Engine management system	Bosch EDC 16
Fuel	Diesel, at least 51 CN or rapeseed methyl ester
Exhaust gas aftertreatment	Exhaust gas recirculation and oxidising catalytic converter
Exhaust emission standard	EU4

Torque and output graph

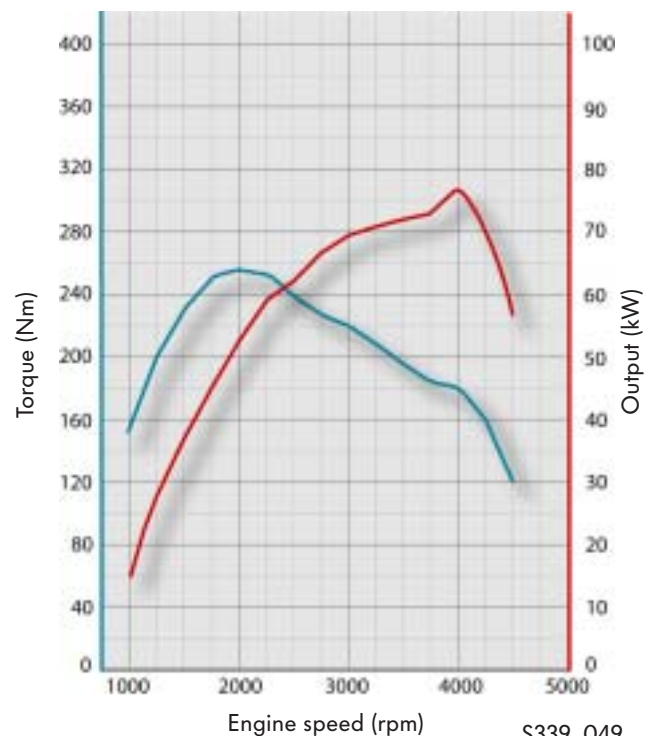

S339_049

Engines

The 2.0l/103 kW TDI engine with 2-valve technology and diesel particulate filter

The 2.0l/103 kW TDI engine has been developed from the 1.9l/96 kW engine.

It was already installed in the Passat model year 2001.

Special technical features

In comparison with the 2.0l engine in the Passat 2001, this engine has the following special features:

- diesel particulate filter
- raised turbocharger rotated by 180°. Thanks to its current installation position, the turbocharger offers better response behaviour and success has been achieved in reducing the charging flow.
- balancer shaft module (see page 34)



S339_052

Technical data

Engine code	BMP
Design type	4-cylinder in-line engine
Displacement	1968 cm ³
Bore	81 mm
Stroke	95.5 mm
Valves per cylinder	2
Compression ratio	18.5 : 1
Max. output	103 kW at 4000 rpm
Max. torque	320 Nm at 1750 rpm to 2500 rpm
Engine management system	Bosch EDC 16
Fuel	Diesel, at least 51 CN
Exhaust gas aftertreatment	Exhaust gas recirculation and diesel particulate filter
Exhaust emission standard	EU4

Torque and output graph

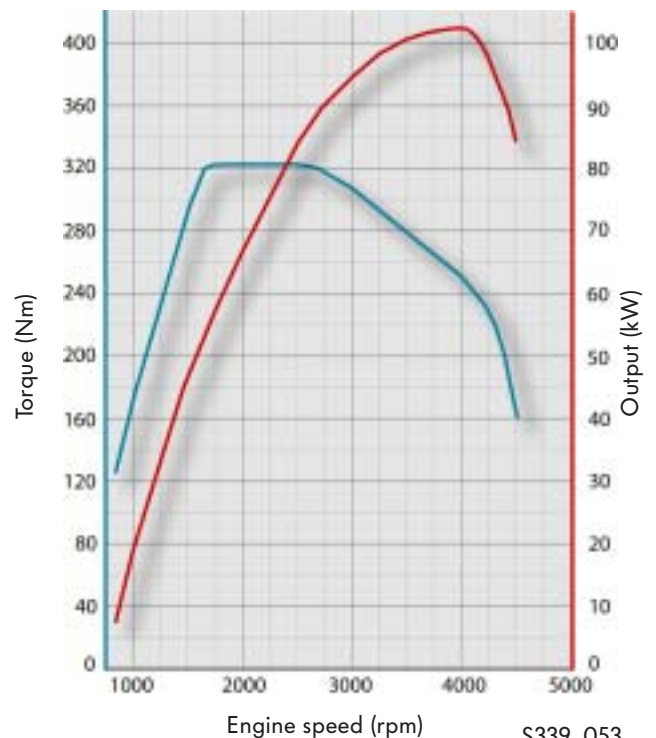

S339_053

The 2.0l/103 kW TDI engine with 4-valve technology

Based on the 2.0l/103 kW 4V TDI engine fitted in the Golf 2004 and Touran, this engine has been further developed for the Passat 2006.

Vibrations and noise emissions have been reduced by a balancer shaft module and new unit injectors with piezo-electric valves.

Special technical features

- unit injectors with piezo-electric valves
- balancer shaft module (see page 34)



S339_050

Technical data

Engine code	BKP
Design type	4-cylinder in-line engine
Displacement	1968 cm ³
Bore	81 mm
Stroke	95.5 mm
Valves per cylinder	4
Compression ratio	18 : 1
Max. output	103 kW at 4000 rpm
Max. torque	320 Nm at 1750 rpm to 2500 rpm
Engine management system	Simos PPD 1
Fuel	Diesel, at least 51 CN
Exhaust gas aftertreatment	Exhaust gas recirculation and oxidising catalytic converter
Exhaust emission standard	EU4

Torque and output graph

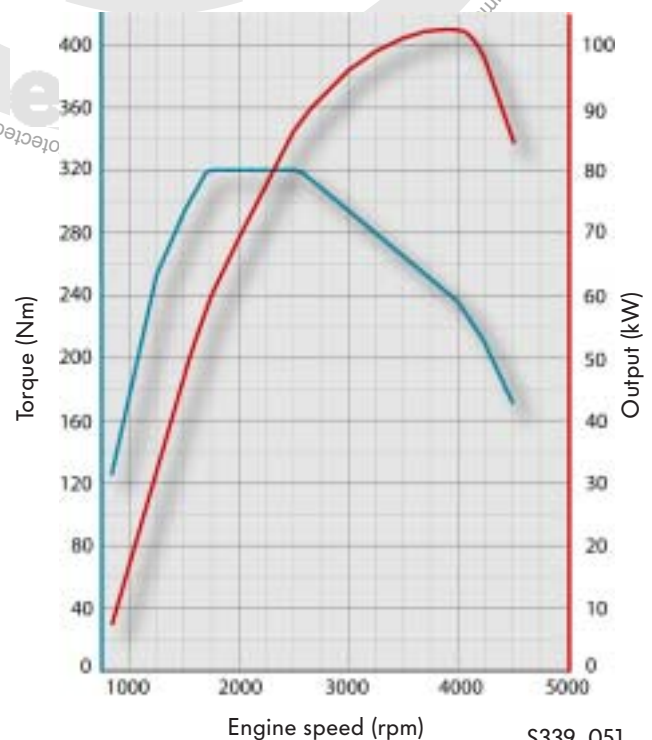

S339_051

The unit injector with piezo-electric valve

The 2.0l/103 kW 4V TDI fitted in the Passat 2006 will be equipped with unit injectors with piezo-electric valves for the first time. This new development offers the following advantages over the unit injector with solenoid valve:

- lower noise emissions
- wider range of injection pressures (130 - 2200 bar)
- more flexible pilot, primary and secondary injection design
- high efficiency



Further information on the unit injector with piezo-electric valve can be found in self-study programme 352 "The unit injector with piezo-electric valve".

The balancer shaft module

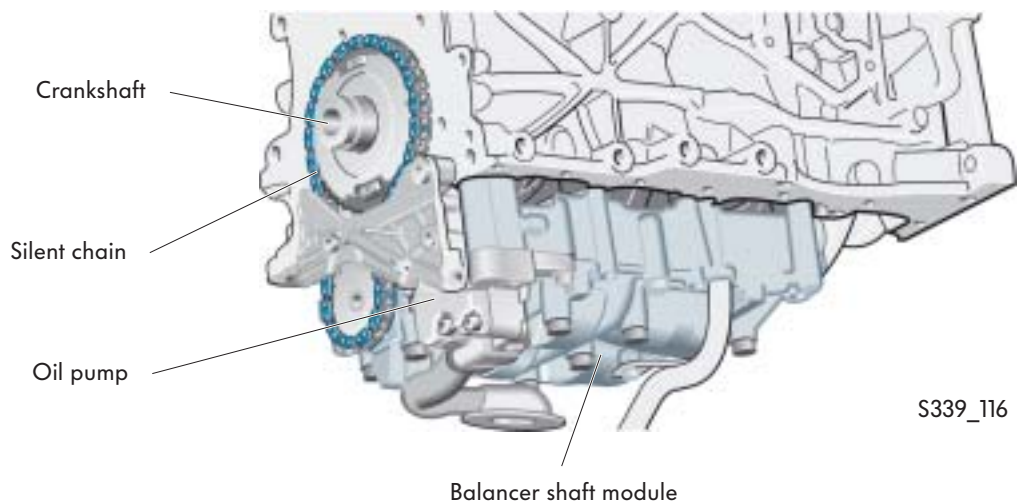

A balancer shaft module, which is located beneath the cylinder block in the oil pan, offers improved comfort. At high speeds, it prevents the occurrence of droning noises in the interior.

The balancer shaft module contains two balancer shafts, which rotate in the opposite direction of the crankshaft and at twice the speed. The balancer shafts are driven by the crankshaft via a silent chain.

The oil pump is secured to the balancer shaft module and is driven by one of the two balancer shafts.

The fuel tank

The fuel tank fitted in the Passat 2006 is comprised of two half shells manufactured from a compound of several plastic, adhesive and barrier layers.

The two half shells are welded together after the fuel tank's internal breather system has been installed.

The fuel tank meets the following extensive requirements:

- Storing the fuel
- Provision of the fuel in a defined condition, with reference to pressure and delivery volume, for the relevant mixture formation system (MPI, FSI and diesel) which is installed
- Measurement of the fuel level
- Compliance with environmental legislation in terms of emissions during operation and refuelling
- Dissipation of critical electrostatic charges and safety functions in the event of a crash, i.e. fire resistance and impermeability.

The fuel tanks for vehicles fitted with front-wheel drive and 4MOTION differ. They are installed above the rear axle in both vehicle versions.

Fuel tank structure for front-wheel drive vehicles

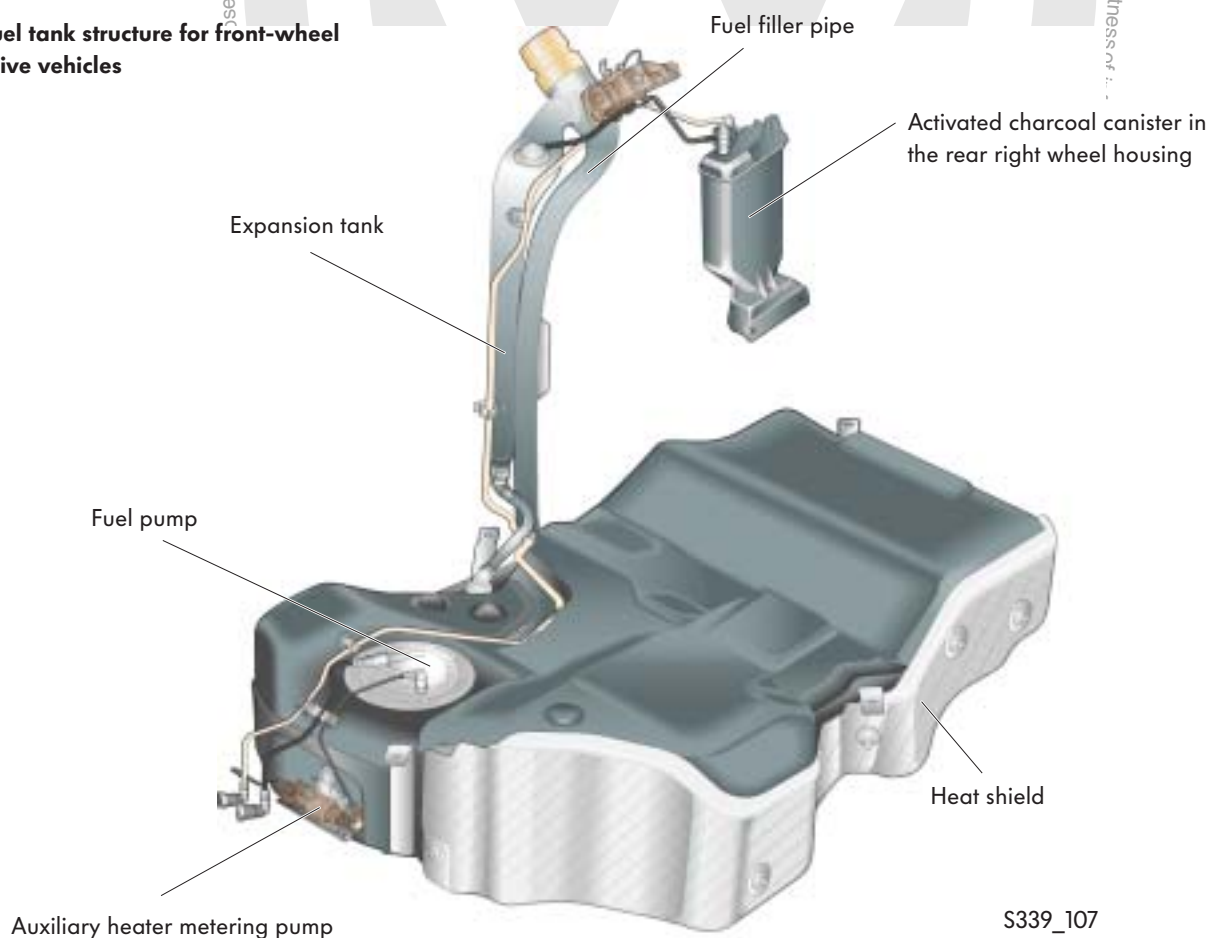

S339_107

Engines

The fuel delivery unit

The fuel delivery unit is installed in the fuel tank. The following components are contained within this unit:

- the fuel pump
- the fuel filter (not in the diesel engine)
- the fuel pressure regulator
- the suction jet pumps
- the potentiometer for the fuel gauge

Fuel delivery unit for vehicles with petrol engines and front-wheel drive (MPI and FSI)

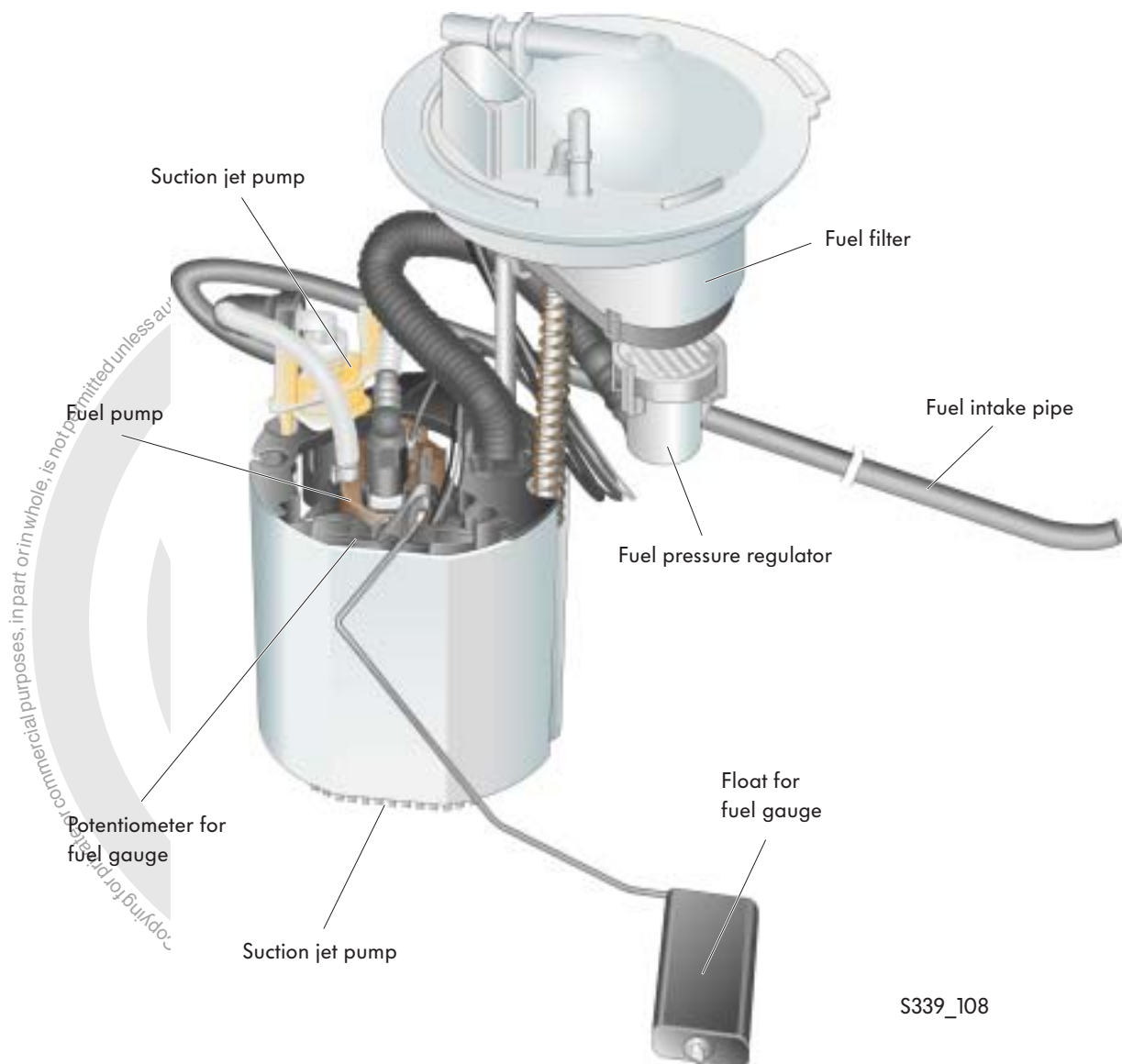

S339_108

The fuel delivery unit supplies the engine with the precisely required quantity of fuel at the precisely required pressure.

It is controlled by the engine control unit according to the fuel requirements.

The fuel delivery units differ due to the fuel required by the individual MPI, FSI and diesel engine systems.

Fuel delivery unit for diesel engines

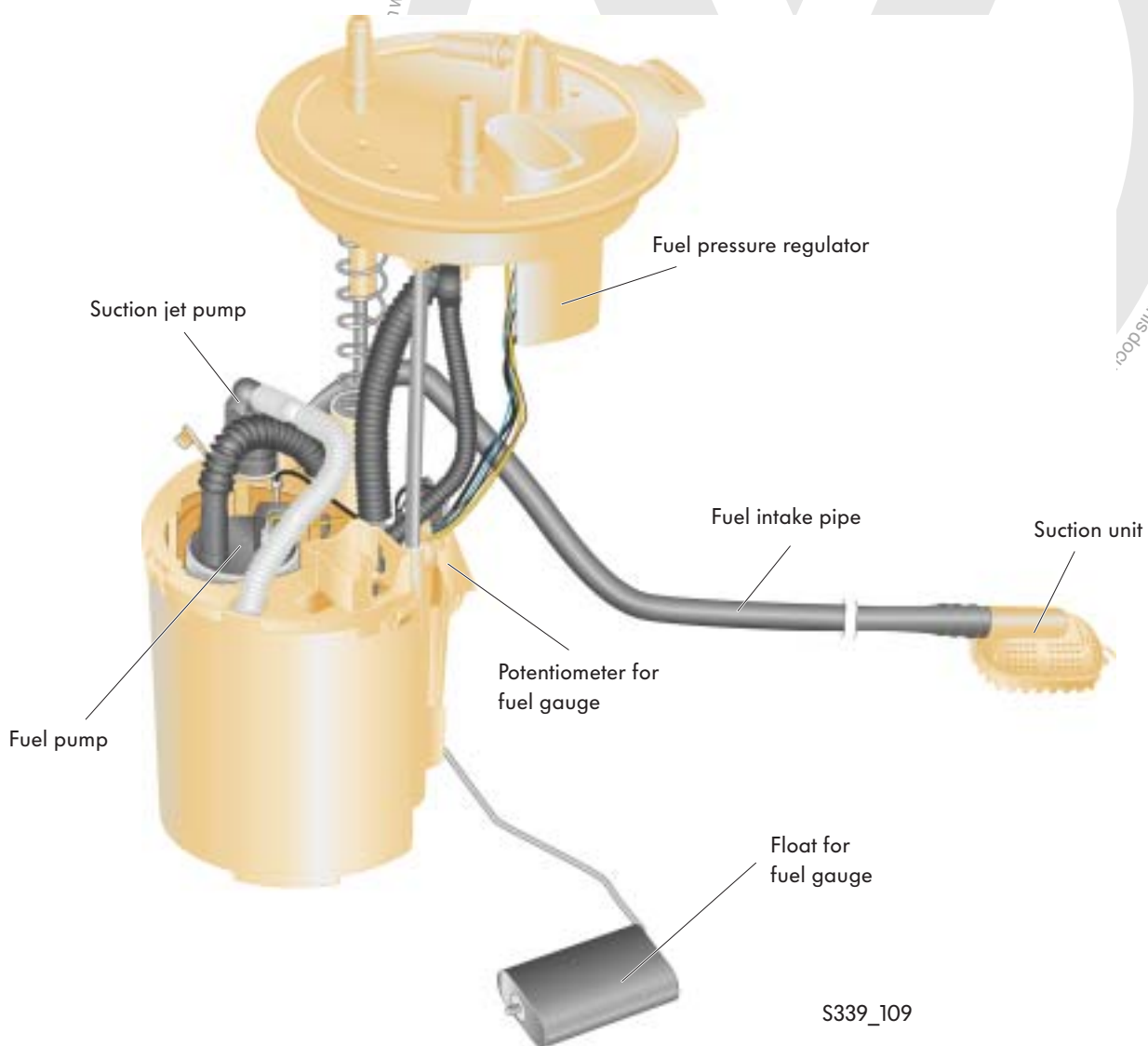

whole, is not permitted unless authorised by Volkswagen AG. Volkswagen AG does not guarantee or accept any liability with respect to the correctness of information in this doc.



Engines

The fuel delivery unit with integrated fuel pressure regulation

Fuel pump and fuel regulation initialisation depend on the engine which is installed.

The MPI engines

The engine's fuel supply is ensured by the constant-delivery fuel pump.

The fuel is pumped, counter to the pressure regulator's pressure level, within the fuel delivery unit by the fuel pump. The engine takes the quantity of fuel which it requires and the surplus quantity flows back into the fuel tank from the pressure regulator.



S339_110

Fuel pump

The FSI engines

The fuel pump provides the engine with the quantity of fuel which it requires and regulates the fuel system pressure. The engine control unit initialises the fuel pump control unit J538 to regulate the fuel pump. The control unit is located on the fuel delivery unit's cover.

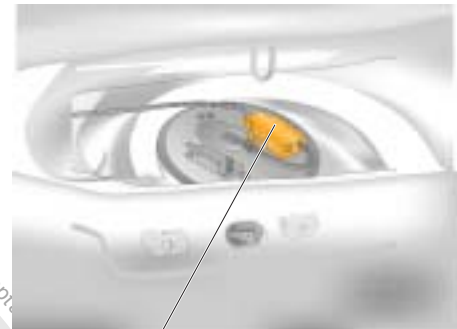

S339_111

Fuel pump control unit J538

The diesel engines

Thanks to their mechanical fuel pump, diesel engines are naturally aspirated. The pre-supply pump is located in the fuel tank. This reduces flow resistance in the fuel lines and ensures improved re-starting behaviour when the fuel tank has been run dry.



S339_112

Fuel pump

The suction jet pumps

Two suction jet pumps are located within the fuel delivery unit. These have the task of continuously filling the fuel pump's reservoir chamber with fuel. This reduces the fuel pump's intake consumption, and the fuel pump always has sufficient fuel at its availability.

Front-wheel drive vehicles have an additional fuel extraction point in the rear section of the fuel tank. This additional extraction point ensures that sufficient fuel is always available on long hill ascents. 4MOTION vehicles have an additional extraction point in the fuel tank's antechamber.

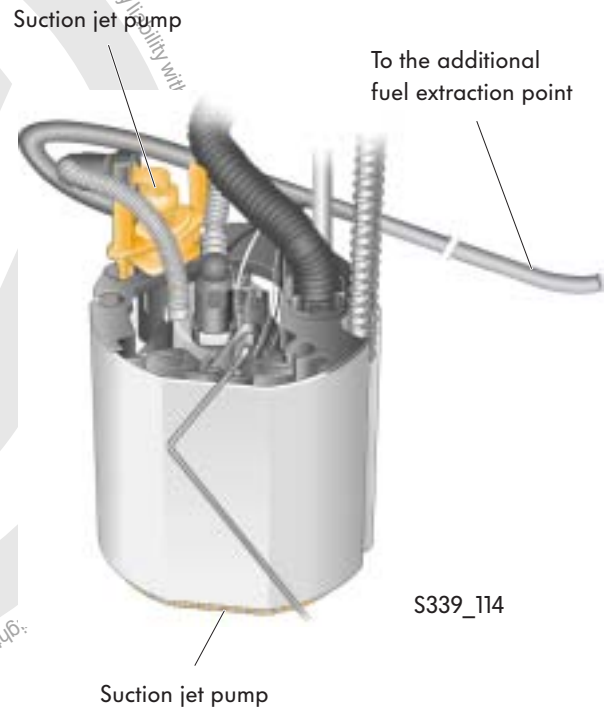

The fuel filter

In vehicles with petrol engines, this is located in the upper section of the fuel delivery unit. It is designed as a lifetime filter.

In vehicles with diesel engines, the fuel delivery unit is not fitted with a fuel filter.

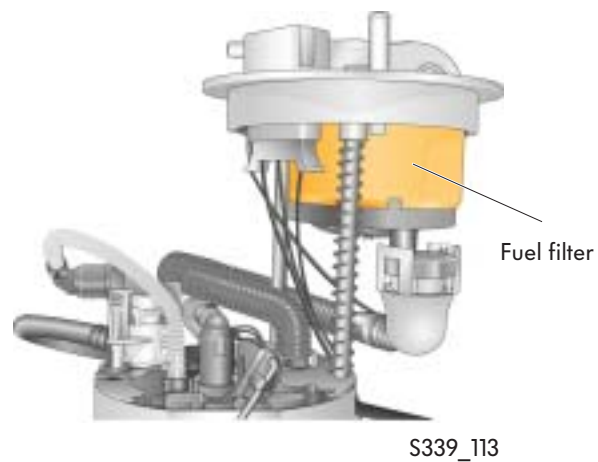

The potentiometer for the fuel gauge

The fuel level is determined by the fuel gauge float and is transmitted to the fuel gauge potentiometer. The determined value is displayed in the fuel gauge in the dash panel.

If the sender is defective, the gauge shows that the fuel tank is empty.



The fuel tank for 4MOTION vehicles

The external shape of the fuel tank is determined by the available installation space, which is in turn determined by the double wishbone rear suspension and the Haldex coupling. Its function is identical to the fuel tank fitted in front-wheel drive vehicles.



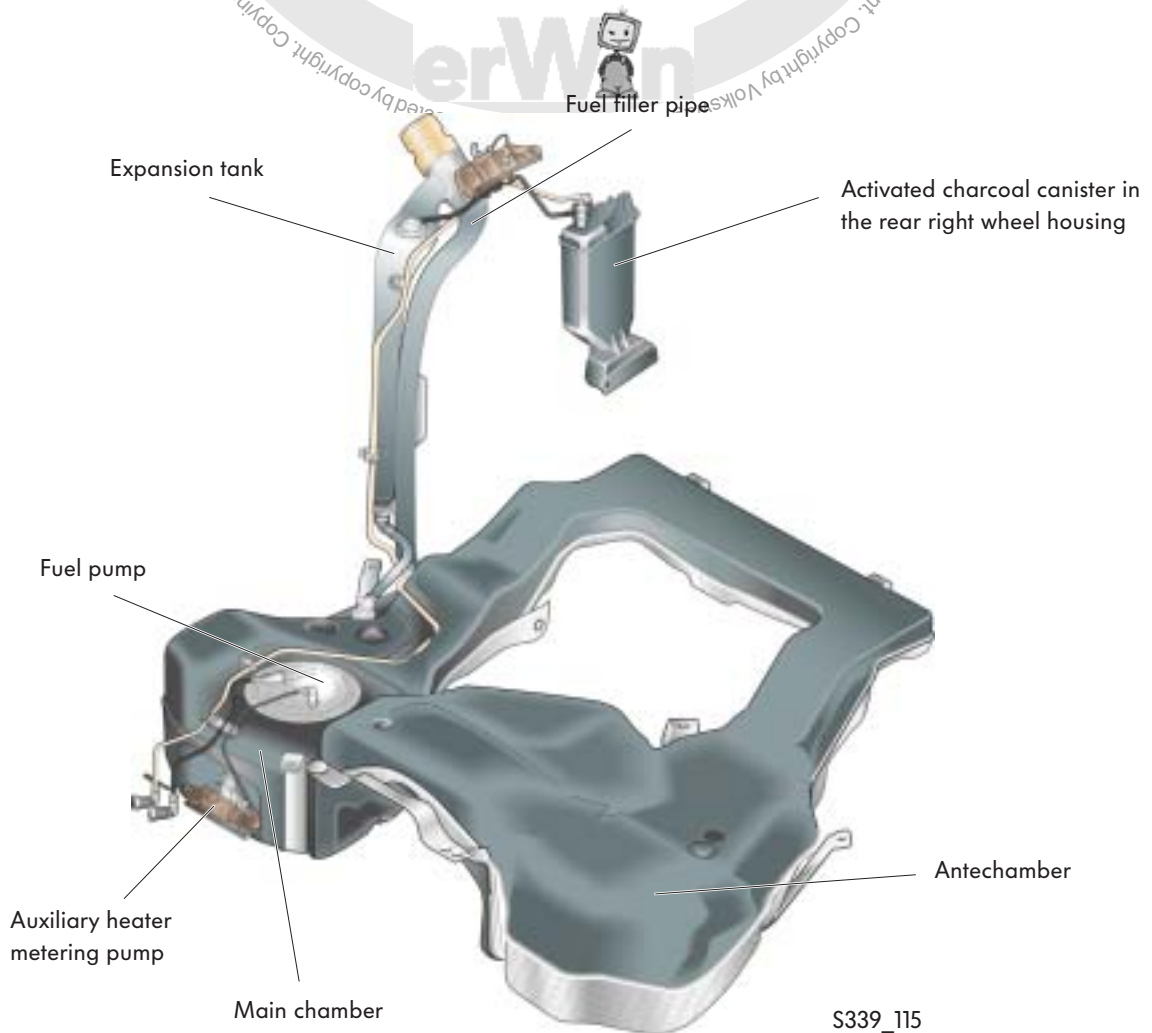

An additional suction jet pump sucks the fuel out from the fuel tank's antechamber (left area in direction of travel).

Fuel tank structure for 4MOTION vehicles



The manual gearboxes - overview

Gearboxes which are already in use within the Group are fitted as the mechanical, manual gearboxes. The gearboxes have merely been adapted for installation in the new Passat. As these gearboxes have already been described more exhaustively in other self-study programmes, they will only be shown in the form of an overview with a brief description here.

	Already fitted in the:	Technical features	Also see self-study programme No.:
 <p>5-speed manual gearbox 0AH</p>	Caddy	<ul style="list-style-type: none"> • Further development of the 02T gearbox • Shaft distance increased, final drive strengthened, housing adapted • Without speedometer sender 	328
 <p>5-speed manual gearbox 0A4</p>	Golf Caddy	<ul style="list-style-type: none"> • Further development of the 02J gearbox • Shaft distance increased, final drive strengthened, housing adapted • Without speedometer sender 	328
 <p>6-speed manual gearbox 0AJ</p>	Touran	<ul style="list-style-type: none"> • Further development of the 02U gearbox • Extended shafts, additional gear wheel pair, new housing cover • Without speedometer sender 	306
 <p>6-speed manual gearbox 02S</p>	Golf Touran	<ul style="list-style-type: none"> • Further development of the 02J gearbox • Extended shafts with additional support, additional gear wheel pair, new, extended aluminium housing cover • Without speedometer sender 	306
 <p>6-speed manual gearbox 02Q</p>	Golf Touran	<ul style="list-style-type: none"> • Further development of the 02M gearbox • Selector shaft modifications, selector forks with stops in the housing, modified support • Without speedometer sender 	306

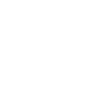

Power transmission

The 6-speed automatic gearboxes 09G and 09M

The 6-speed automatic gearboxes set new standards in terms of dynamics and economy in the segment of transversely mounted stepped automatic gearboxes.

They are particularly characterised by

- Low weight,
- High shifting comfort,
- Compact gearbox dimensions and
- High ratio between first and top gear.

The automatic gearbox with the code 09G has already proved its worth in the Golf 2004, Touran and New Beetle.

In design and functional terms, automatic gearbox 09M corresponds to automatic gearbox 09G. It has merely been reinforced to cope with higher torque transmission in the area of the couplings and brakes and in the planetary gear sets.

Torque transmission

09G = 250 Nm

09M = 450 Nm



The design and function of the selector lever correspond to those in the Golf 2004. The ignition key withdrawal lock is new.



Further information on these automatic gearboxes can be found in self-study programme No. 309

The 6-speed Direct-Shift Gearbox 02E

Following its successful, initial launch in the Golf 2004 and Touran, the Direct-Shift Gearbox is now also being fitted in the Passat.

The Direct-Shift Gearbox combines the advantages of a manual gearbox:

- High efficiency, i.e. low fuel consumption on a par with a manual gearbox and
- spontaneous frictional connection with very short shift times

with the advantages of an automatic gearbox:

- High comfort (no manual clutch actuation or shifting)

The gearbox offers the following characteristics:

- Six forward gears and one reverse gear
- Standard and sports gearbox programmes
- Tiptronic selector level and steering wheel switches
- Mechatronics
- Hill-holder function
- Creep control
- Pressure oil filter and oil cooler located on the gearbox
- Maximum torque 350 Nm.



S339_057

Thanks to its design, it meets both the requirements of active, sporty drivers and also the high comfort requirements of rather more relaxed, forward-looking drivers who prefer automatic gearboxes.

The design and function of the selector lever correspond to those in the Golf 2004. The ignition key withdrawal lock is new.



Further information on the Direct-Shift Gearbox can be found in self-study programme No. 308.



Power transmission

The ignition key withdrawal lock

The ignition key withdrawal lock is fitted in vehicles with automatic gearboxes.

It prevents the ignition key from being removed if the selector lever is not set to the "P" position.

If the selector lever is set to a driving position or the "N" position, the vehicle is not secured against rolling away.

The ignition key withdrawal lock is comprised of the following components.

- The selector lever locked in position "P" switch F319
- The steering column electronics control unit J527 and
- The ignition key withdrawal lock solenoid N376 in the entry and start authorisation switch E415

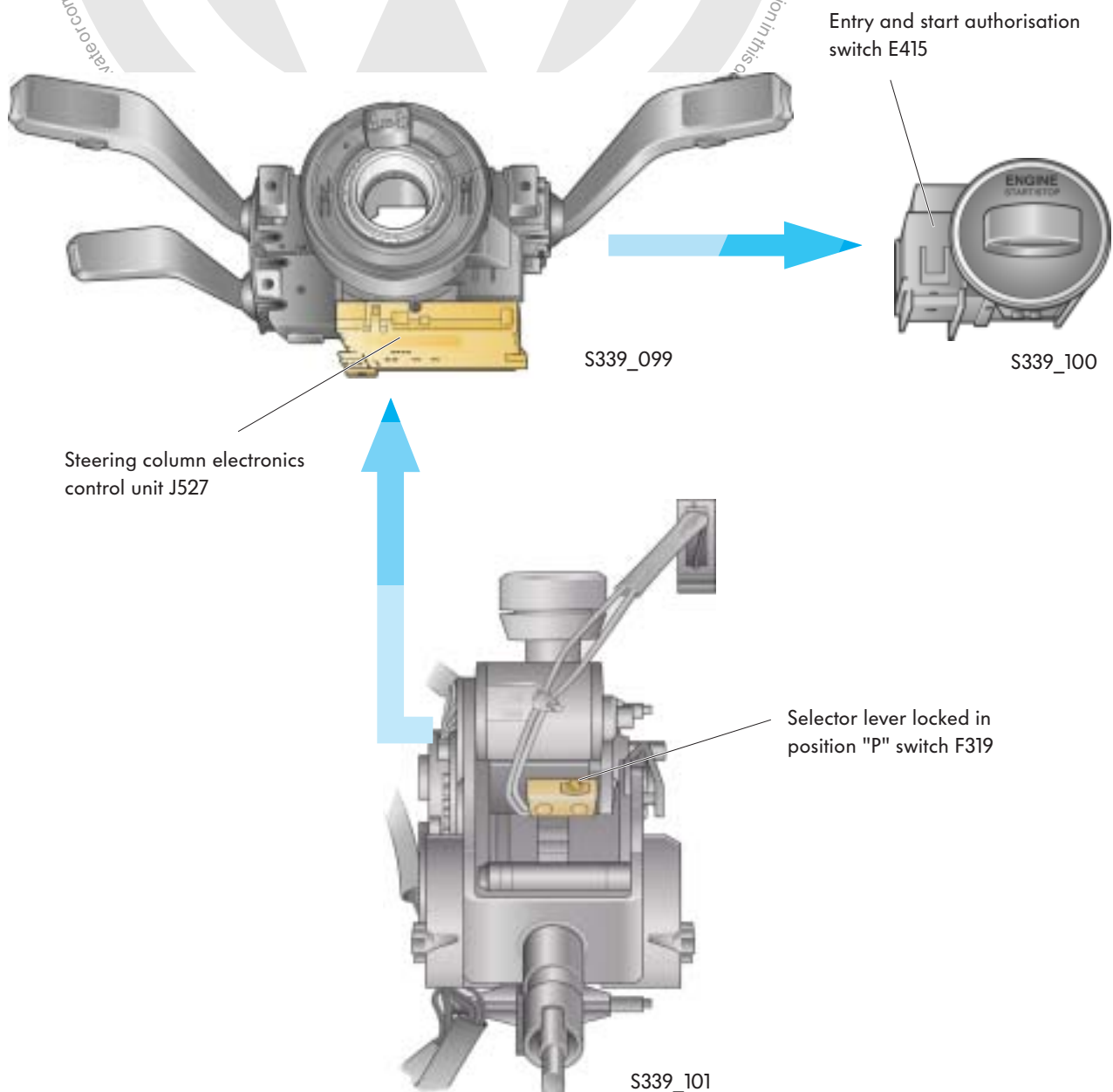

How it works:

Ignition switched on, selector lever in driving position or "N"

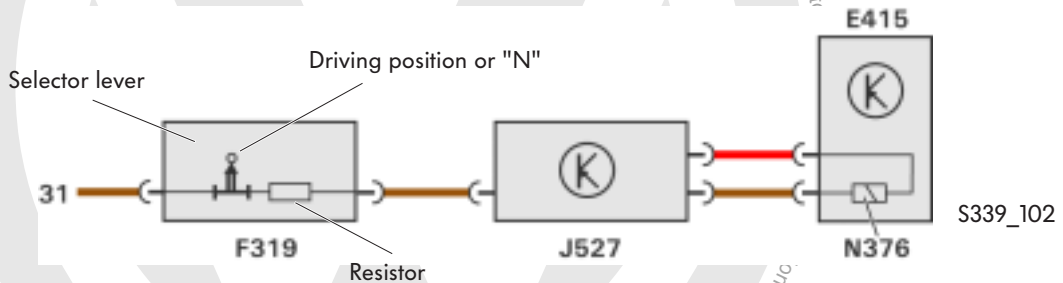

If the selector lever is set to a driving position or "N" position, switch F319 is closed.

It supplies solenoid N376 with current and thereby activates the ignition key withdrawal lock. The ignition key cannot be removed.

Due to the fact that switch F319 is closed, the current circuit to control unit J527 is made. Based on the made current circuit, control unit J527 detects the selector lever position.

A resistor limits the voltage to control unit J527.

Ignition switched on, selector lever in "P"

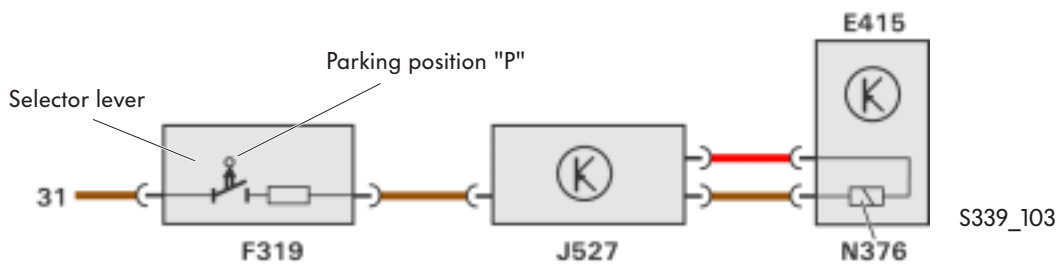

If the selector lever is set to "P", switch F319 is open.

Opening switch F319 interrupts the current circuit to control unit J527. Based on the broken current circuit, the control unit detects that the selector lever is in position "P", and the ignition key can be removed.

Effects in the event of signal failure

If the signal from switch F319 fails or solenoid N376 cannot be initialised, the ignition key can be removed although the selector lever is not in position "P".

The flashing gear indicator notifies the driver that the selector lever is not in position "P" and that the vehicle is not secured against rolling away.

Running gear

The running gear

The running gear fitted in the Passat 2006 will be the benchmark in the mid-size class vehicle segment. This is achieved by consistent further development of the tried-and-tested axle components in VW's modular running gear system.

Modern, lightweight McPherson strut front suspension and the state-of-the-art 4-link rear suspension therefore remain in use. The Passat's handling behaviour, which is outstanding as a result of these components, is rounded off with the electromechanical power steering system familiar from the Golf 2004.

- Safety steering column with electric steering column lock
- TRW ABS/ESP with vehicle/trailer stabilisation
- Electromechanical power steering
- Lightweight strut front suspension
- Dynamic starting-off assist
- Self-supporting tyres, optional

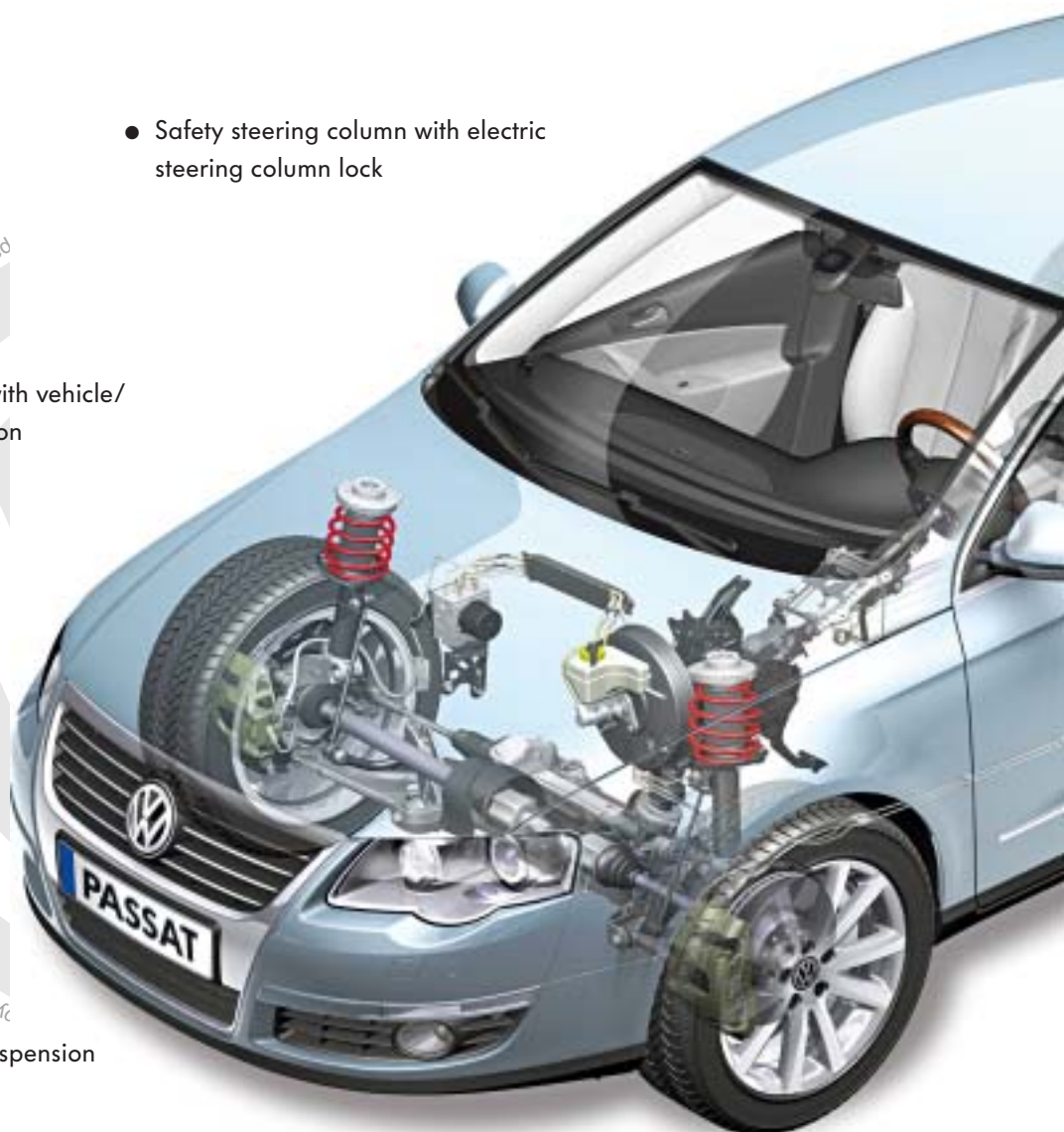

Copyright: Copying for private or commercial purposes, in part or in whole, is not permitted unless authorised

However, there are also significant innovations in the Passat's running gear, e.g.

- The electromechanical parking brake with AUTO HOLD function,
- The new ABS/ESP system from TRW (Thompson-Ramo-Wooldrigde) and
- The tyre pressure monitor system from Hella.

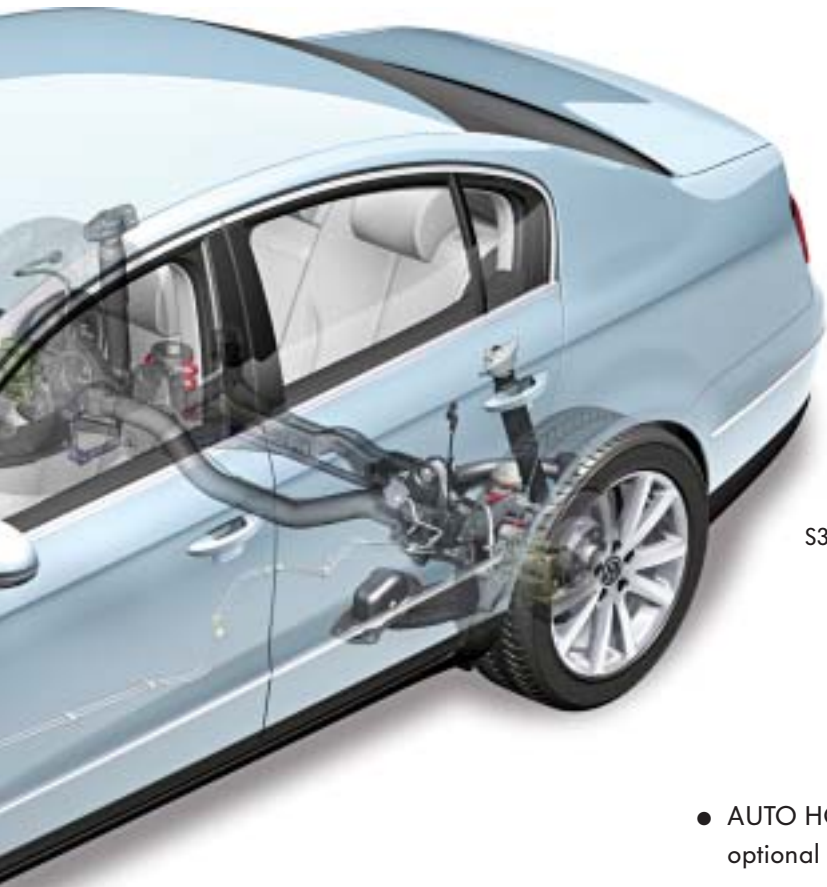

- Tyre pressure monitor, optional
- Tyre pressure monitor system, optional

- AUTO HOLD function, optional

- Four-link rear suspension

S339_058

- Electromechanical parking brake



More detailed information on the tyre pressure monitor systems and the electromechanical parking brake can be found in SSP 347 "Tyre pressure monitor systems" and in SSP 346 "The electromechanical parking brake".

Volkswagen AG. Volkswagen AG does not guarantee or accept any liability with respect to the correctness of information in this document. Copyright by Volkswagen AG.



Running gear

The front axle

The front axle is the familiar spring strut suspension with lower wishbones.

The aluminium subframe is designed in one piece and is joined to the body with 4 bolts.



The rear axle

The front-wheel drive Passat's rear axle is a compact four-link rear suspension in lightweight design.



The 4MOTION rear axle

The 4MOTION rear axle is based on that fitted in the front-wheel drive vehicles and is linked to the body via large bonded rubber bushes.

The steering

The Passat 2006 is fitted with electromechanical power steering. This is familiar from the Golf 2004. Due to the high front axle loads in the Passat 2006, the characteristic power steering curves have been adapted in the control unit.

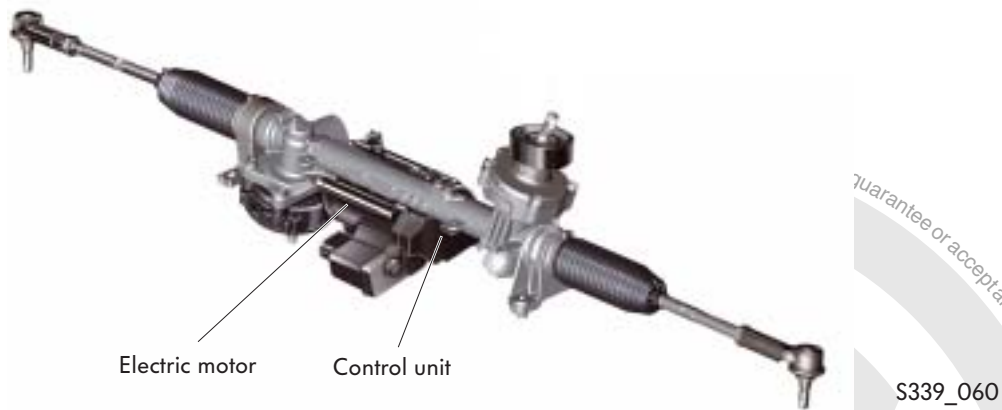

The steering column

The steering column fitted in the Passat 2006 can be adjusted vertically by 60 mm and horizontally by 50 mm. It is equipped with an electric steering column lock. This has enabled the steering lock to be positioned in a crash-optimised area. The position of the steering column adjustment clamping lever has also been crash-optimised and therefore lies outside of the possible knee impact area. This has been achieved by reversing the clamping lever's rotational direction.

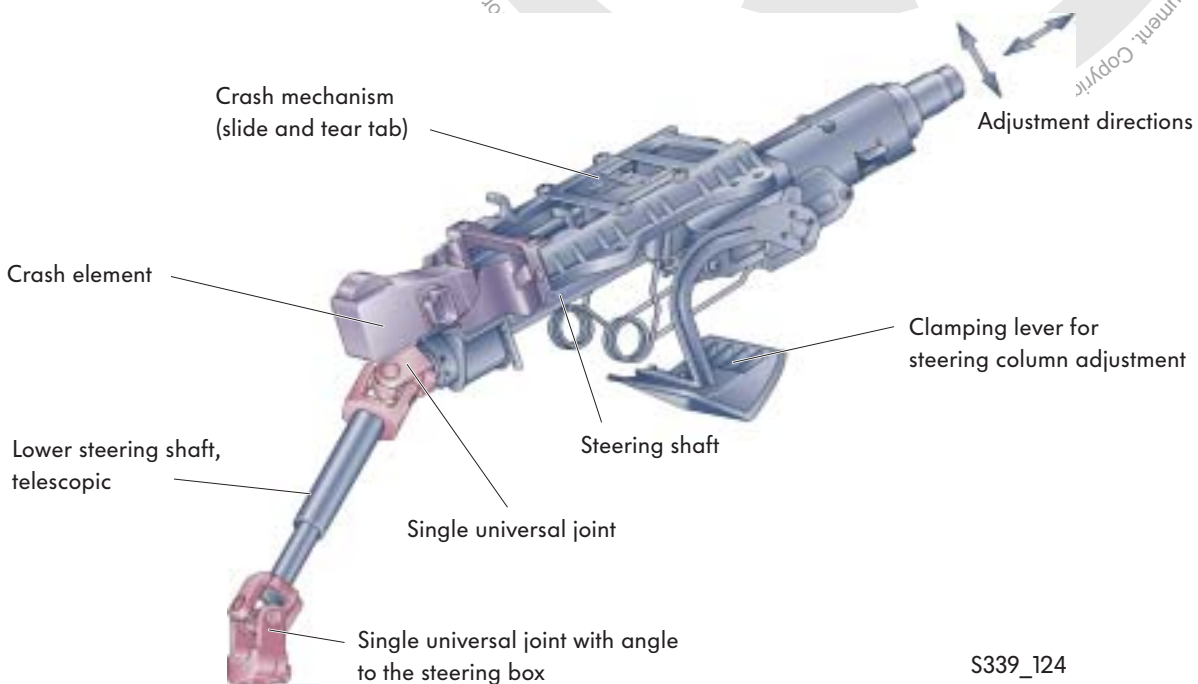

Running gear

The brake system

The performance and weights of new vehicles are constantly on the increase. This is due to the continuous rise in safety and convenience equipment. The vehicle's brake system therefore has to be adapted to these conditions. Consequently, a new brake system has also been developed for the Passat 2006.

This encompasses:

- A new ESP system from TRW (Thompson-Ramo-Wooldrigde) with vehicle/trailer stabilisation
- Large wheel brakes
- A brake disc wiper
- A tandem brake master cylinder with brake light switch
- A brake servo with "dual rate characteristics"
- A hydraulic brake servo (HBV), for vehicles with 16.1/85 kW and 2.0I/110 kW FSI engines only in combination with automatic gearboxes



S339_061



A new brake fluid will be introduced along with the Passat 2006. Please observe the notes in the workshop manual.

The anti-lock brake system ABS/ESP TRW EBC 440

A TRW ESP system will be fitted for the first time at Volkswagen. In addition to a hydraulic brake assist system, this system includes an AUTO HOLD function as an interface to the electromechanical parking brake, plus a vehicle/trailer stabilisation system and a brake disc wiper.

The ESP system is fitted as standard in the Passat 2006.

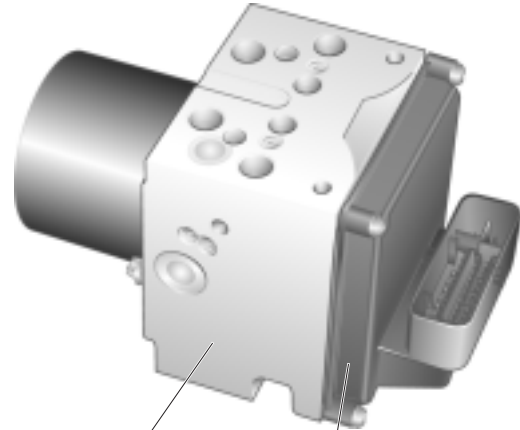

S339_125

Hydraulic unit

Control unit

Hydraulic unit with brake pressure sender

To facilitate comprehension, the hydraulic unit and the control unit are shown separately (folded open).

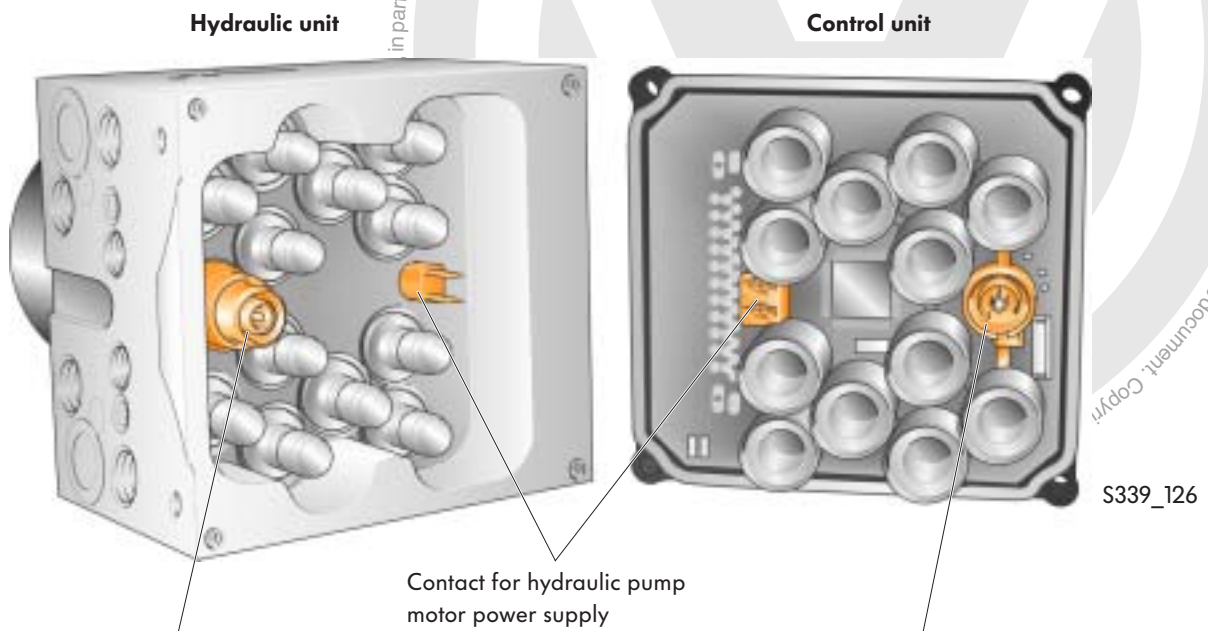

Hydraulic unit

Control unit

Brake pressure sender 1 G201

Contact for hydraulic pump
motor power supply

Spring contact for
brake pressure sender 1 G201

S339_126



Running gear

The brake disc wiper

A film of water may form on the brake disc in severe rain or if the road is wet, for example; this reduces the coefficient of friction between the brake disc and the brake pads on braking. As a result, the braking effect is temporarily changed until the water film is dissipated by frictional heat.

This is combated by the new function in the ESP system – the brake disc wiper.

By regularly applying the brake pads to the brake discs from time to time at low pressure, this displaces the water film and shortens the stopping distance. This is carried out by cyclical initialisation of the hydraulic pump, which builds up the low brake pressure in the brake system.

This process in the brake system is not perceptible to the driver.

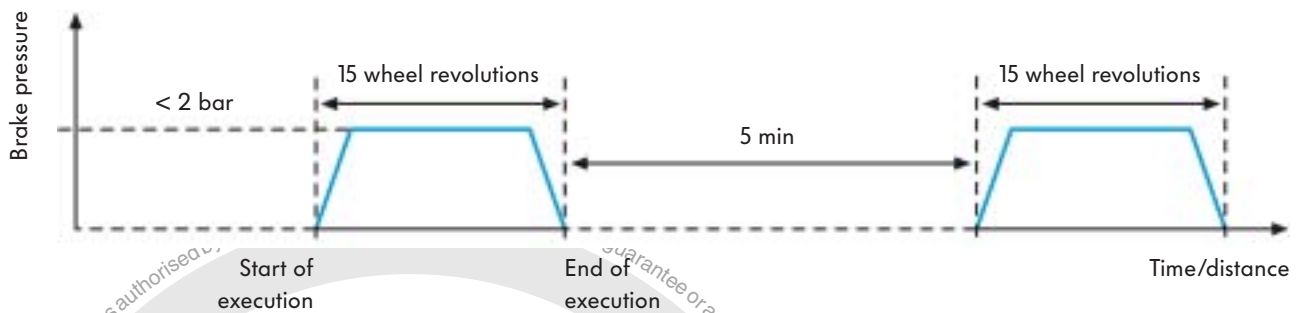

S339_145

The vehicle/trailer stabilisation system

A vehicle/trailer stabilisation system will be launched in the Passat 2006 along with the TRW EBC 440 ESP system.

This function is an ESP sub-system.

An unstable vehicle/trailer is stabilised by specifically braking the wheels.

The towing vehicle's yaw rate and steering angle are used as input variables to achieve this.

The trailer's pendulum movements are passed on to the towing vehicle. This leads to yawing moments and lateral forces which are detected by the yaw rate sender and the steering angle sender and are processed in the ESP control unit.

The vehicle/trailer's instability is combated by building up pressure in the system and actuating individual valves in the ESP hydraulic unit.

The brake servo - dual rate booster

All left-hand drive vehicles will be fitted with an 11" brake servo.
The right-hand drive vehicles will be fitted with a 7/8" tandem brake servo.

Implementation of the "dual rate characteristics" represents a significant innovation.



S339_144

A progressive characteristic curve is achieved thanks to the brake servo's modified internal design. Even at low pedal forces, this offers higher brake pressures than conventional brake servos. Deceleration nevertheless commences gently when actuated in the normal manner.

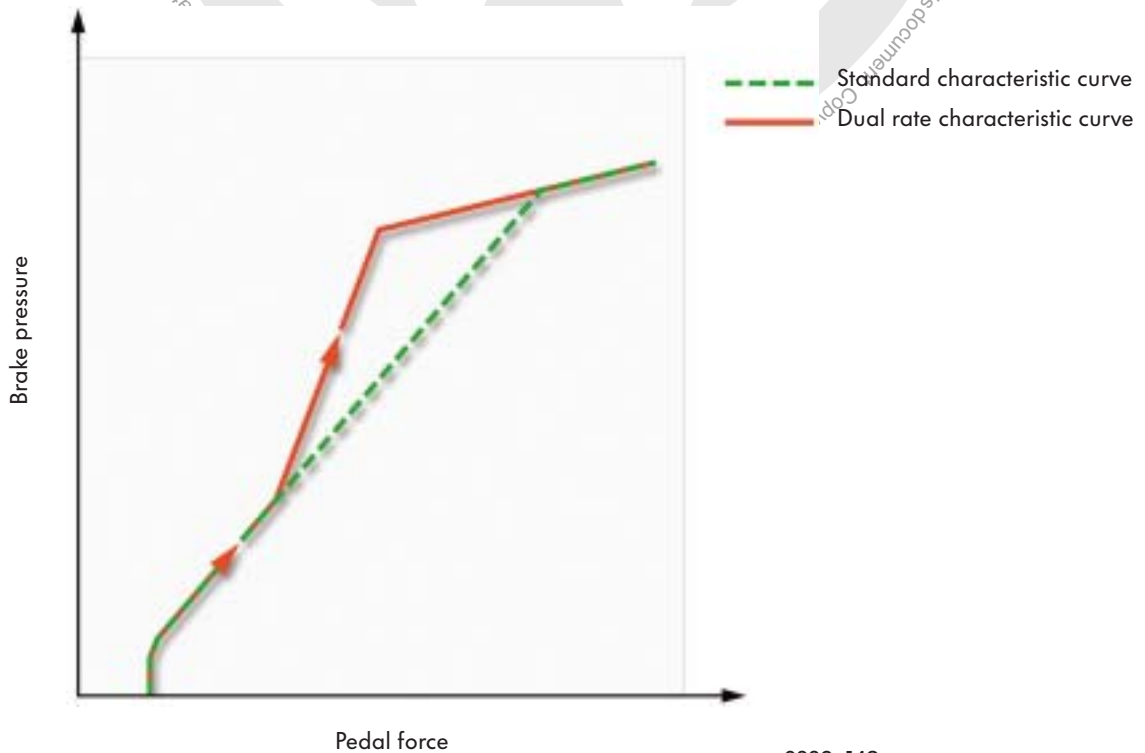

S339_142



Running gear

The brake light switch F

The brake light switch F is bolted to the brake master cylinder. It is used to detect whether the brake pedal is actuated. When the brake pedal is actuated, the brake lights are switched on.

Signal usage

The brake lights are switched on via the vehicle electrical system control unit.

In addition, the engine control unit prevents the vehicle from accelerating when the brake and accelerator are actuated at the same time. To do this, the quantity of fuel injected is reduced or the ignition timing and throttle valve are adapted.

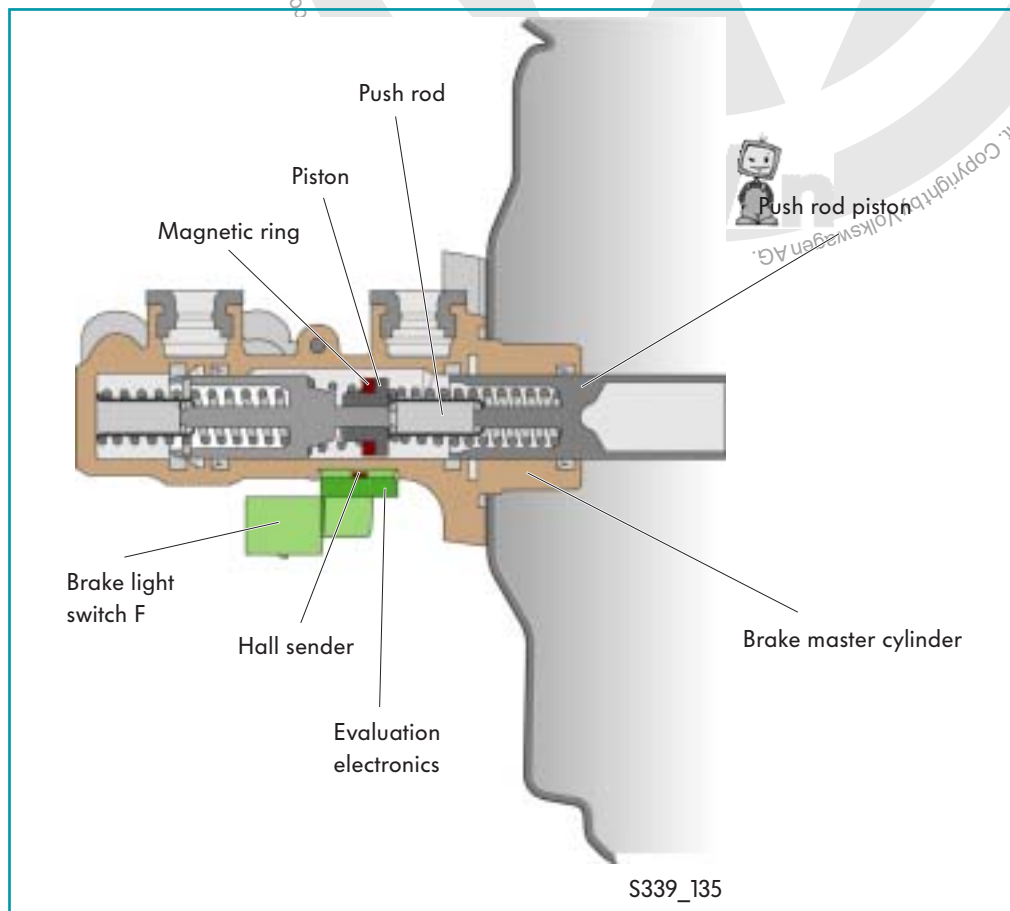
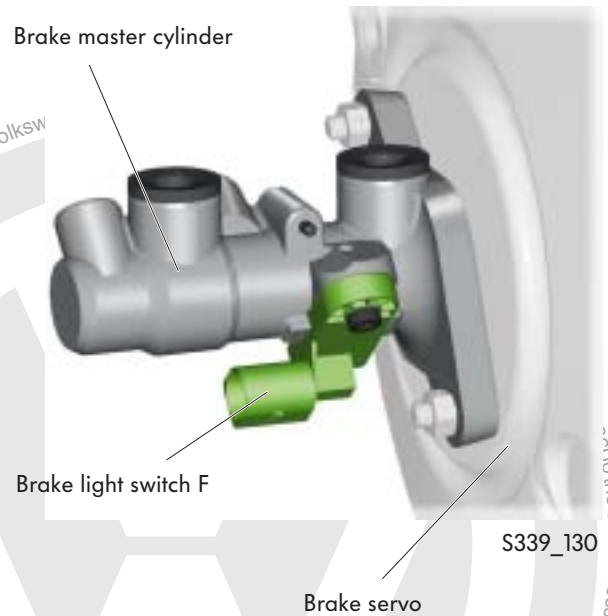

How it works:

On actuation of the brake pedal, the push rod in the brake master cylinder pushes the piston with magnetic ring (permanent magnet).

Brake pedal not actuated:

When the brake pedal is not actuated, the piston and magnetic ring are at rest.

The evaluation electronics of brake light switch F transmit a signal voltage of 0 - 2V to the engine control unit and the vehicle electrical system control unit. This is used to detect that the brake pedal is not actuated.

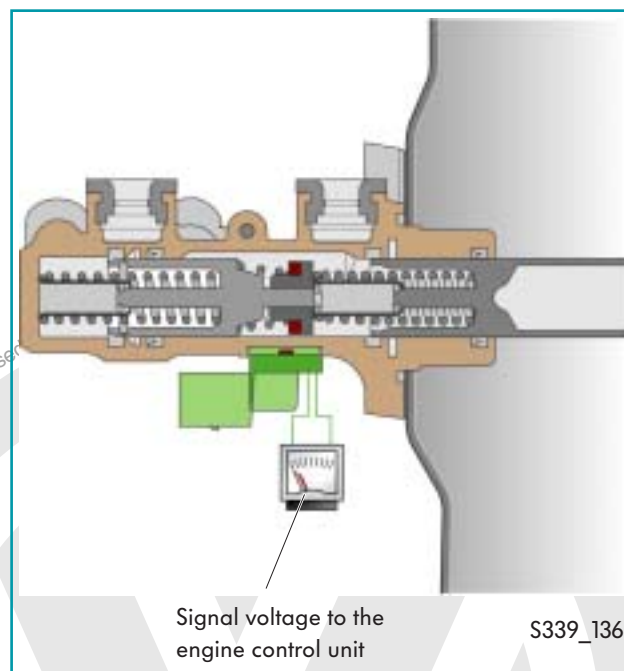

Brake pedal actuated:



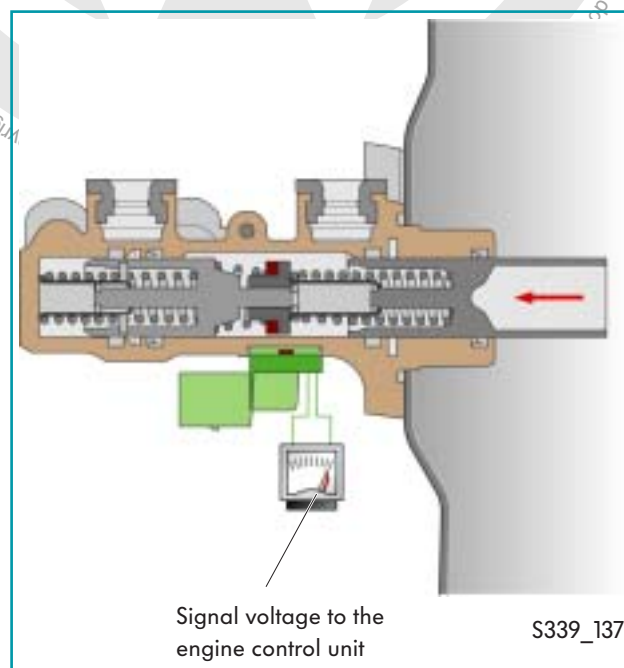

When the brake pedal is actuated, the piston is moved over the hall sender.

When the piston's magnetic ring passes the hall sender's switching point, the evaluation electronics transmit a signal voltage, which is up to 2V lower than the vehicle electrical system voltage, to the engine control unit. This is used to detect that the brake pedal is actuated.



Running gear

The brakes

Engine	Front brake in mm	Rear brake in mm
75 kW to 118 kW	<p data-bbox="550 544 667 573">Ø 312 x 25</p>  <p data-bbox="715 1104 815 1133">S339_140</p> <p data-bbox="496 1189 715 1218">Bolted swivel bearing</p>	<p data-bbox="1118 544 1235 573">Ø 286 x 12</p>  <p data-bbox="1286 1104 1386 1133">S339_138</p>
as of 132 kW	<p data-bbox="555 1339 671 1368">Ø 345 x 30</p>  <p data-bbox="719 1899 820 1928">S339_141</p> <p data-bbox="496 1984 715 2013">Bolted swivel bearing</p>	<p data-bbox="1123 1339 1240 1368">Ø 310 x 22</p>  <p data-bbox="1286 1899 1386 1928">S339_139</p>



The automatic levelling system

The Sachs automatic levelling system is a self-inflating shock absorber which will be installed on the Passat's rear suspension instead of the conventional shock absorber.

It will be available as an optional extra at a later point in time.

The automatic levelling system does not require any separate components, as it makes use of relative movements between the rear axle and the body to maintain a specific vehicle level.

Thanks to the automatic levelling system, full spring travel is always available for all load conditions. This guarantees optimal ride comfort and vehicle safety. Axle and tyre wear is additionally reduced.



S339_153



Protected by copyright. Copying for private or commercial purposes, in particular for advertising, is not permitted. Information in this document. Copyright by Volkswagen AG. Volkswagen AG does not guarantee or accept a

erWin

Running gear

The wheels and tyres

Summer tyres	Wheel	
205/55 R16 91 H/V	Steel Alloy	6.5J x 16 ET 42 mm
215/55 R16 93 H/V	Alloy	7J x 16 ET 45 mm
235/45 R17 74 V	Alloy	7.5J x 17 ET 47 mm
Winter tyres (suitable for snow chains)		
205/55 R16 91 H/V	Steel Alloy	6.5J x 16 H2 ET 42 mm
Spare wheel		
<p>Mobility set comprised of a sealant spray bottle and compressor or</p> <p>temporary spare wheel T125/70 R18 on 3.5J x 18 or</p> <p>a full-size spare wheel if a variable luggage compartment floor is fitted</p>		



More detailed information on the tyre pressure monitor systems can be found in self-study programme No. 347 "Tyre pressure monitor systems".

The self-supporting tyre

Self-supporting tyres will be introduced in the Passat 2006. These Bridgestone RFT tyres (**R**un **F**lat **T**yre) remain stable even in the event of full pressure loss. At a maximum speed of 80 km/h, the vehicle is still able to cover a distance of up to 250 kilometres (depending on the load and the vehicle).

This is made possible by a special side wall reinforcement and innovative, extremely heat-resistant rubber compounds. A reinforced bead coil ensures that the tyre is securely seated on the wheel – even in the event of total pressure loss.

One additional advantage is:

Bridgestone RFT tyres do not require special wheels and can simply be mounted on standard wheels.

Tyre structure



Tyre comparison

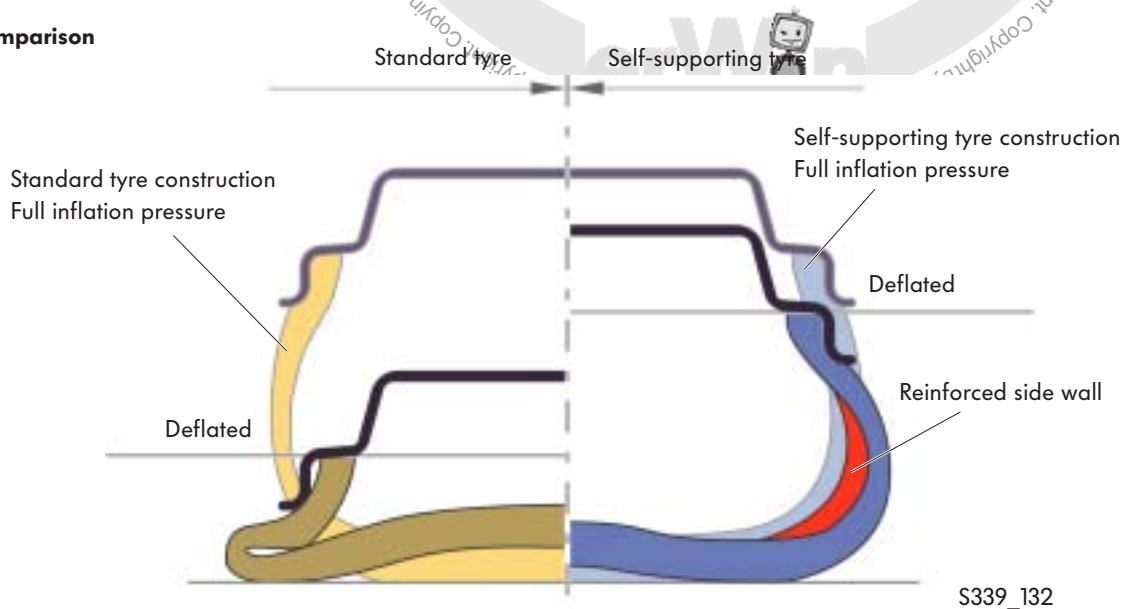

Electrical system

The fuse boxes and relay positions in the vehicle electrical system

The installation locations

The vehicle electrical system in the Passat 2006 has a decentralised structure and is therefore comparable to that in the Golf 2004. Due to the multitude of electrical consumers, the Passat has an additional fuse box on the right-hand side of the dash panel.

Distribution of the fuse boxes and relay positions to different locations enables rapid and precise fault diagnosis.

Fuse box, right of dash panel



Fuse and relay box, left of engine compartment



Strip fuses in the fuse and relay box



Protected by copyright. Copying for private or commercial purposes, in part or in whole, is not permitted unless authorized by the copyright holder.

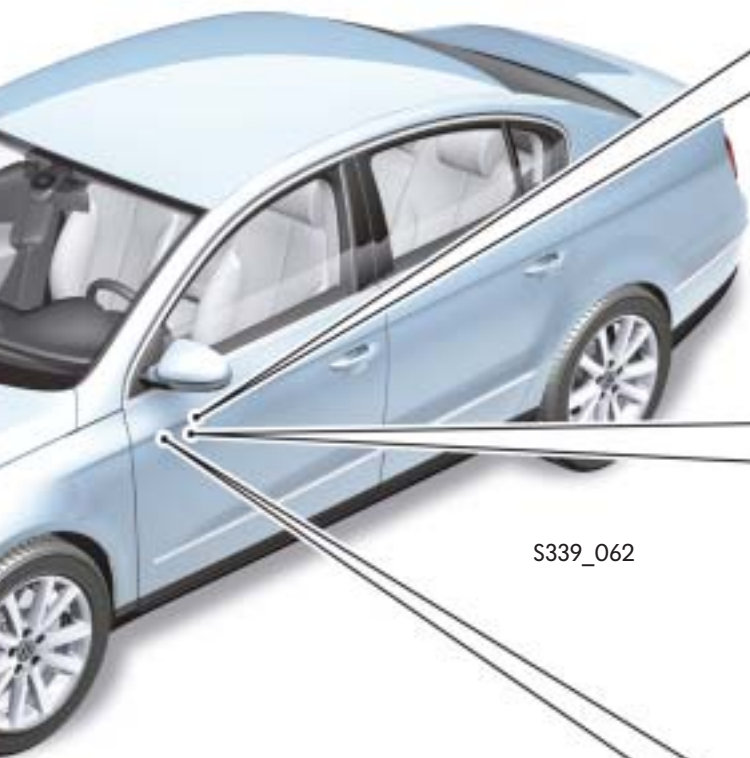

S339_062



Relay holder on the vehicle electrical system control unit



Relay holder on the vehicle electrical system control unit

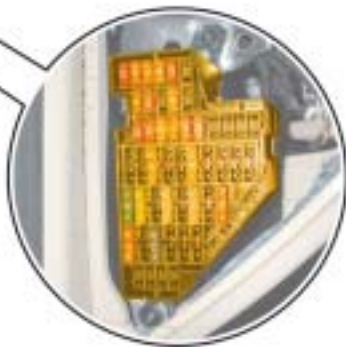

Fuse box, left of dash panel

does not guarantee or accept any liability with respect to the correctness of information in this document. Copyright by Volkswagen



For more detailed information on the electrical system, please refer to self-study programme 340 "The Passat 2006 electrical system".

Electrical system

The networking concept

To ensure flawless data exchange between the individual control units, these are networked via various data bus systems.

The data bus diagnostic interface J533 (gateway) acts as the interface for the following data buses:

- CAN powertrain data bus
- CAN comfort data bus
- CAN infotainment data bus
- CAN instrument cluster data bus
- CAN diagnostic data bus

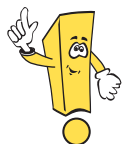
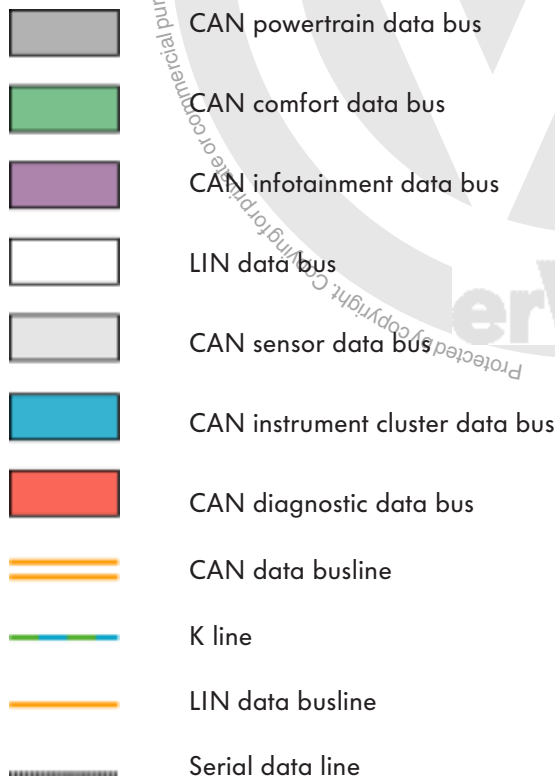

In addition to the CAN data bus, certain electrical components are networked via the LIN data bus.

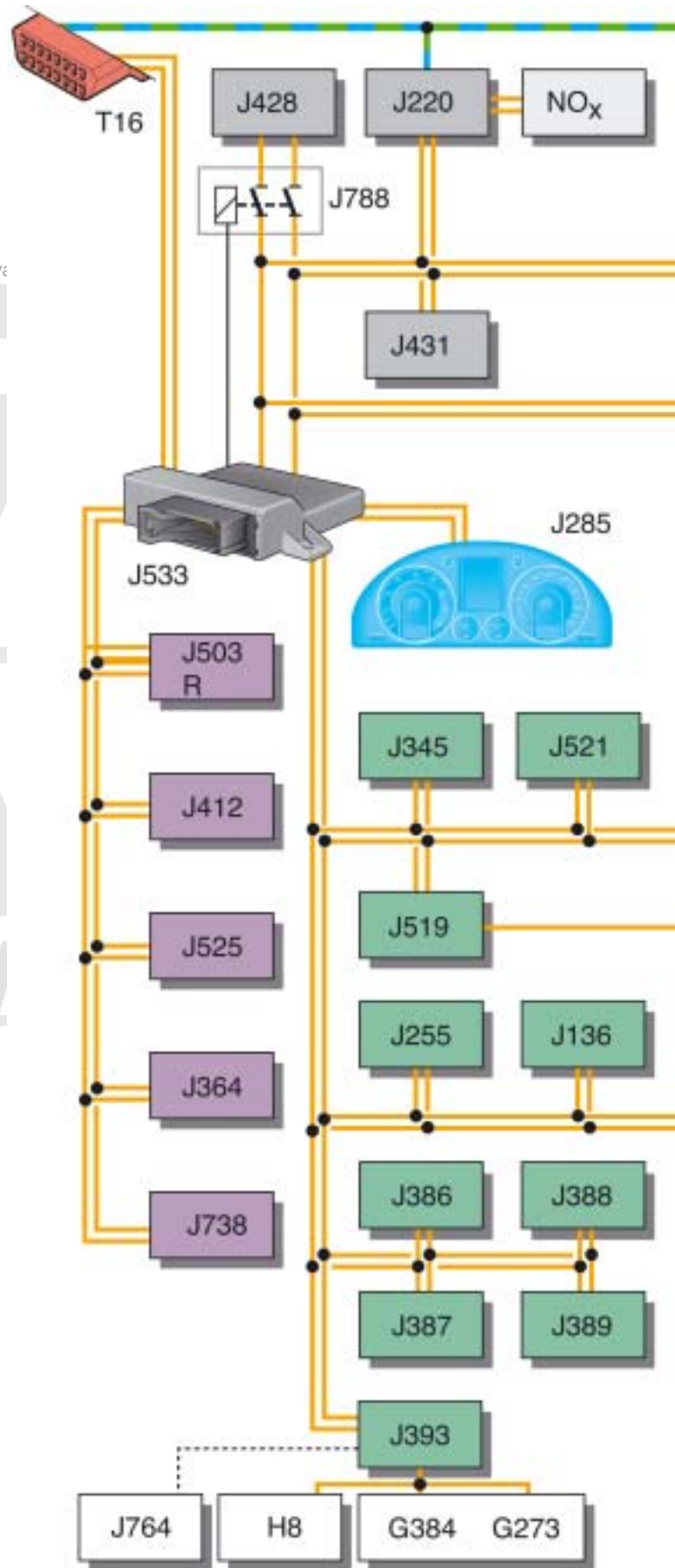

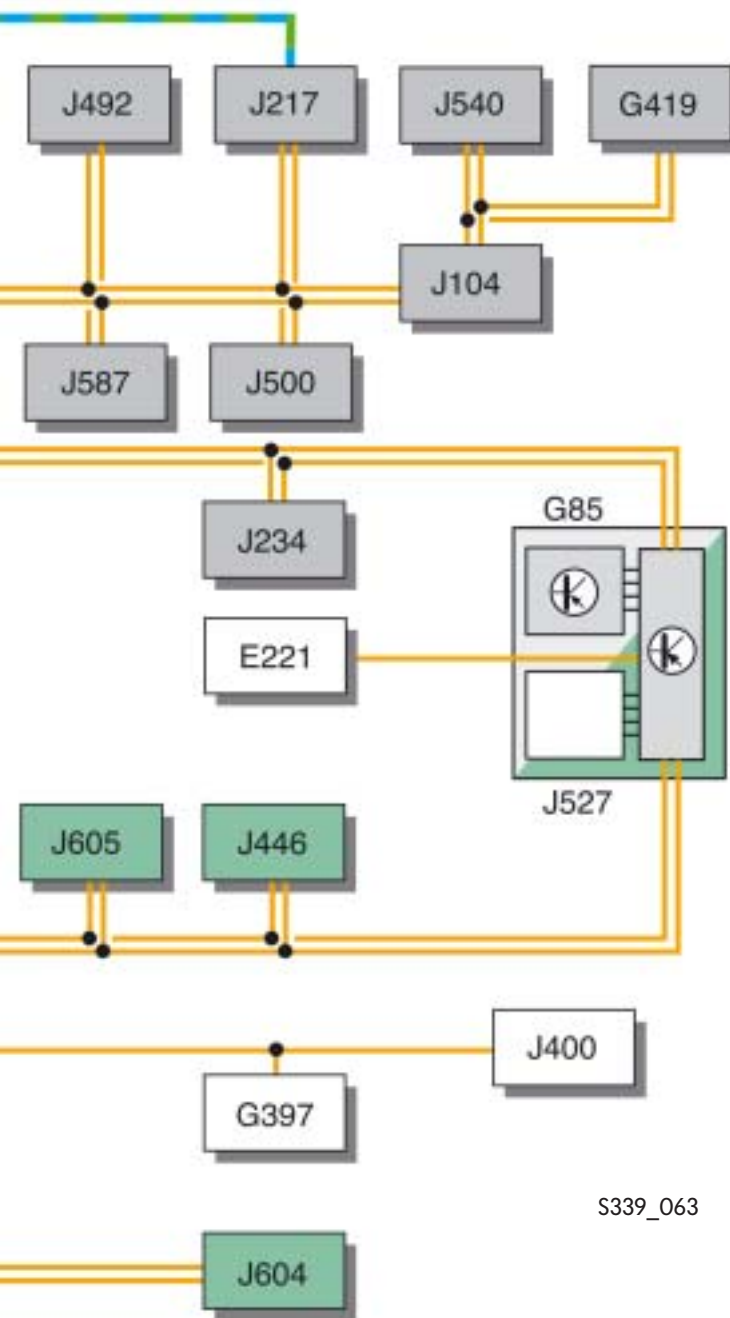

Legend

- D Ignition/starter switch
- E221 Operating unit in steering wheel
- G85 Steering angle sender
- G273 Interior monitoring sensor
- G384 Vehicle inclination sender
- G397 Rain and light detector sensor
- G419 ESP sensor unit
- H8 Anti-theft alarm system horn
- J104 Control unit for ABS
- J136 Seat and steering column adjustment control unit with memory function
- J217 Automatic gearbox control unit
- J220 Motronic control unit
- J234 Airbag control unit
- J255 Climatronic control unit
- J285 Control unit with display in dash panel insert
- J345 Trailer detector control unit
- J364 Auxiliary heater control unit
- J386 Driver door control unit
- J387 Front passenger door control unit
- J388 Rear left door control unit
- J389 Rear right door control unit
- J393 Convenience system central control unit
- J400 Wiper motor control unit
- J412 Mobile telephone operating electronics control unit
- J428 Adaptive cruise control unit
- J431 Headlight range control, control unit
- J446 Parking aid control unit
- J492 Four-wheel drive control unit
- J500 Power steering control unit
- J503 Control unit with display for radio and navigation
- J519 Onboard supply control unit
- J521 Front passenger seat adjustment with memory control unit
- J525 Digital sound package control unit
- J527 Steering column electronics control unit
- J533 Data bus diagnostic interface
- J540 Electromechanical parking brake control unit
- J587 Selector lever sensor control unit
- J604 Auxiliary air heater control unit
- J605 Rear lid control unit
- J738 Telephone controls control unit
- J764 Electronic steering column lock control unit
- J788 Isolation relay for CAN powertrain bus
- NO_x NO_x sensor
- R Radio
- T16 16-pin connector (diagnostic connection)

S339_063



Electrical system

The inverter

An optional 230 V/50 Hz European socket can be ordered for the Passat 2006.

An inverter, which is firmly connected to the socket, is installed in the vehicle to generate the alternating voltage. This unit is located in the rear centre console instead of the cup holder.



S339_064

The 230 V socket is designed without an earthing contact and can be operated at a maximum, continuous output of 150 W. As the temporary (2 min) peak output, approx. 300 W can be drawn off.

Voltage can only be drawn from the socket when the engine is running (terminal 61). Besides the engine speed signal line, a voltage supply (terminal 30) and a ground connection (terminal 31) link the inverter to the vehicle electrical system.. Galvanic separation from the alternating voltage level has been implemented.

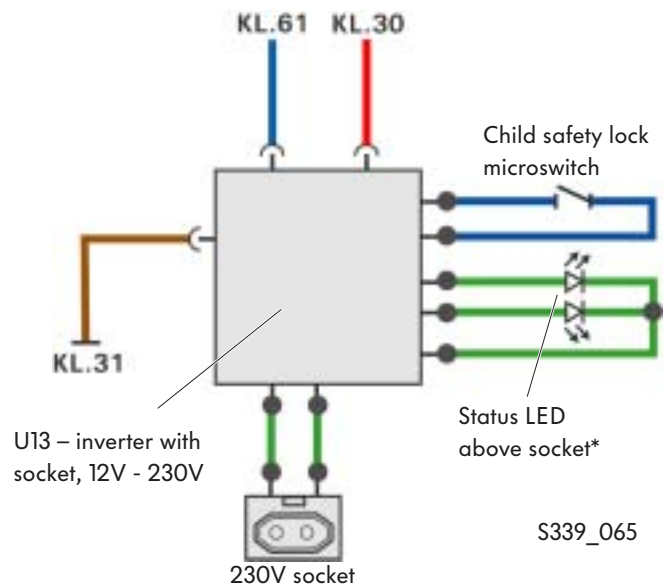

S339_065

- * Red flashing = malfunction
- Green = ready to operate



No repairs may be carried out on 230V systems. If the socket or the inverter is defective, the entire assembly must therefore be exchanged.

Entry and start authorisation switch E415

The entry and start authorisation switch is part of the drive authorisation system.

The ignition key is designed without a key bit, as the vehicle is started by pushing the key rather than turning it.

The emergency key serves

- to mechanically unlock the driver's door if the vehicle cannot be opened using the radioreMOTE control,
- to deactivate the front passenger airbag,
- to lock the glove box,
- to lock and release the rear seat bench and
- to activate the child safety lock in the rear doors.

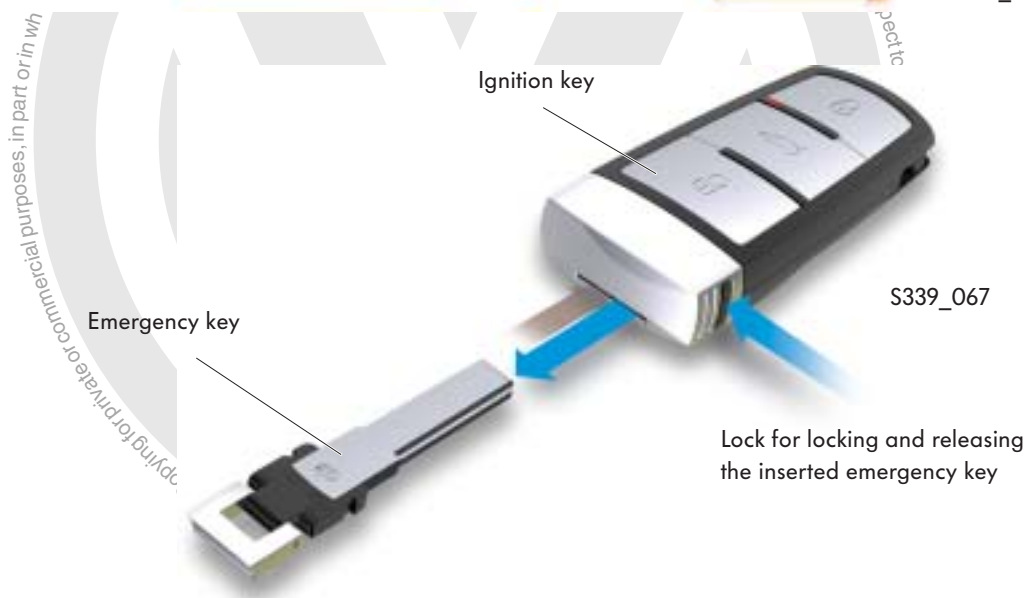

Heater and air conditioner

Climate control

Thanks to the new powertrain concept with a transversely mounted engine, the heater/air conditioner concept already implemented in the Golf 2004, Touran and Caddy 2004 can be employed.

Two different systems are available in the Passat 2006:

- The semi-automatic heater and air conditioner "Climatic"
- The heater and air conditioner 2C-"Climatronic"

An identically designed air conditioner unit, which has been adapted to the relevant vehicle equipment, is used for both systems.

The main difference is in air distribution flap actuation. 2C-Climatronic is fitted with an additional fresh air/air flow flap.

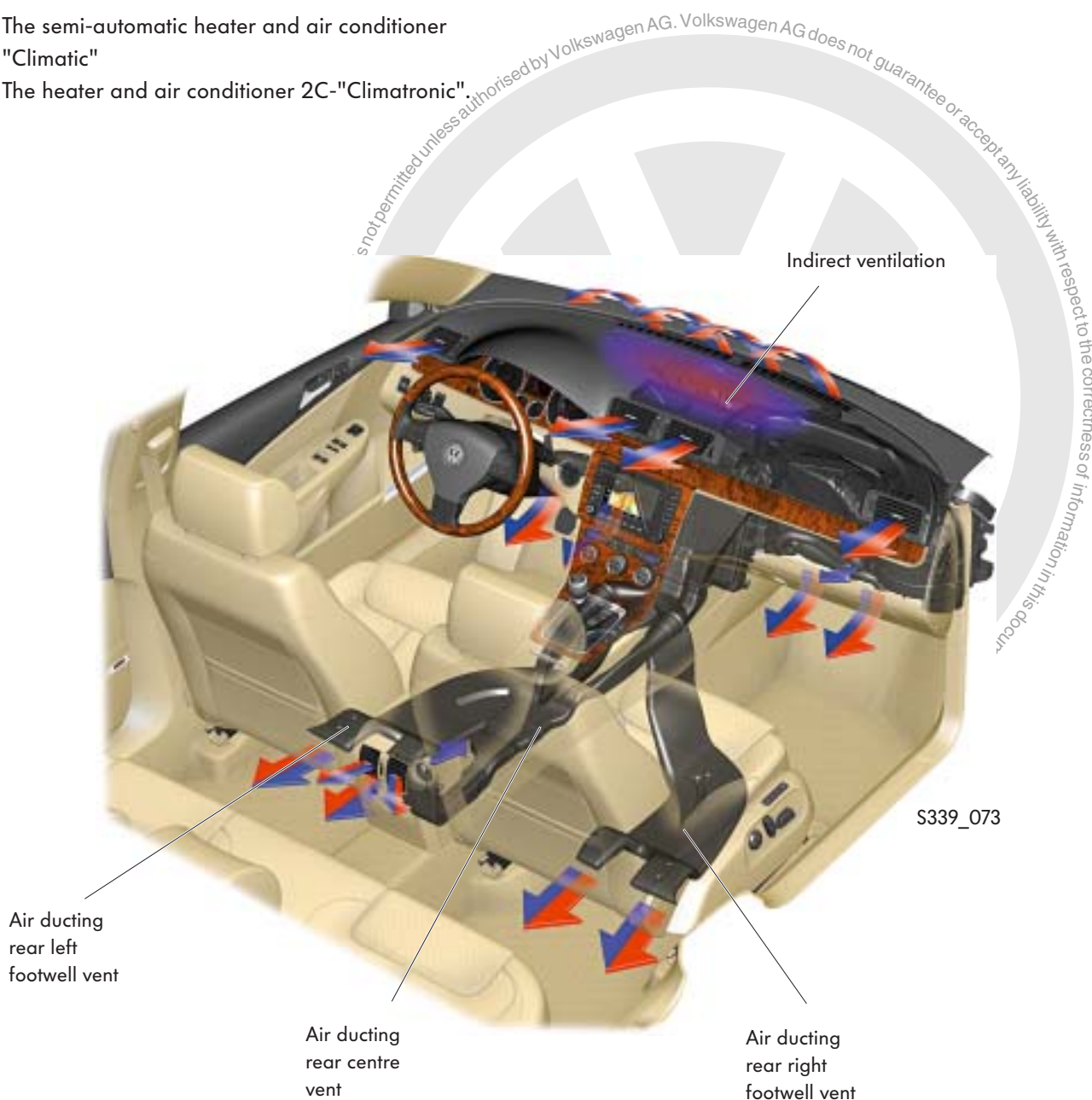

Operation

Different control panel versions are available depending on the equipment fitted in the vehicle:

- with or without instant heat button for the auxiliary coolant heater
- with or without potentiometer for the seat heating
- with or without potentiometer for the heated windscreen

The Climatic system

In the Climatic system, the vehicle's entire interior is comprised to form a single climatic zone.

The desired temperature is set at the left rotary switch.

The rotary switch is linked to a potentiometer, which passes the temperature command on to the Climatic control unit. The control unit then forwards a calculated flap position value to the temperature flap positioning motor.

Climatic is able to control the pre-set temperature by monitoring the vent and interior temperature.

The air distribution flaps are actuated via a flexible shaft in the Climatic system.

The air conditioner is switched on and off via the ECON button. In ECON mode, the additional heater is also switched off in vehicles fitted with diesel engines.

The Climatic air conditioner unit is equipped with a combined fresh air/recirculated air flap.

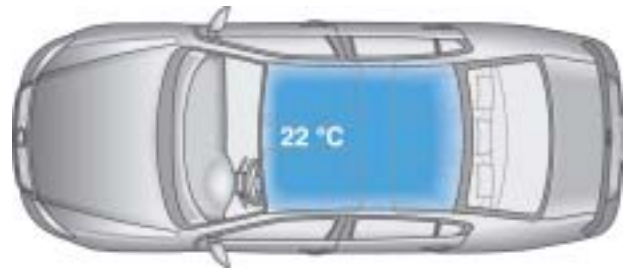

S339_075

Climatic control panel

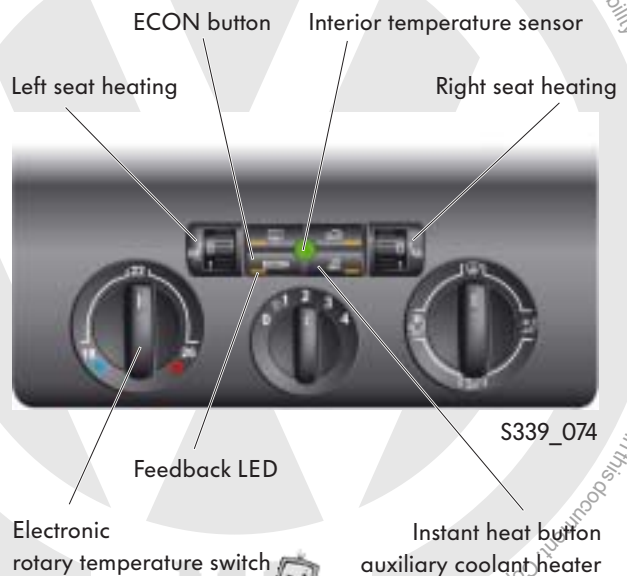

S339_074



Heater and air conditioner

The 2C-Climatronic system

In the 2C-Climatronic system, the interior is subdivided into two climatic zones. This means that the temperatures desired on the driver and front passenger side can be set independently of each other in the range from 16 °C to 29.5 °C. The climatic zones are separated by two temperature flaps inside the air conditioner unit.

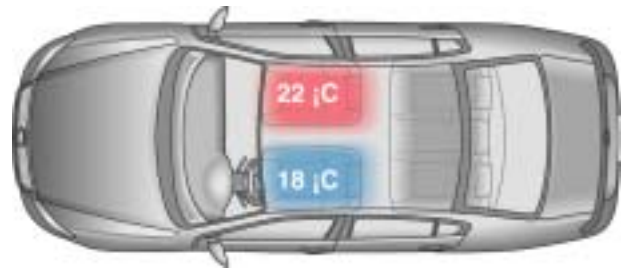

S339_077

All air distribution and temperature control flaps are actuated via positioning motors with an integrated feedback potentiometer. Maintenance of the preset interior temperature and optimal air distribution are thereby controlled and monitored by the Climatronic control unit.

The 2C-Climatronic system can be operated in automatic or manual mode.

In addition to the Climatic system, 2C-Climatronic is fitted with a fresh air flow flap, which is closed as of 100 km/h as speed increases, in order to keep the volume of fresh air which is supplied constant. One further function which is available is speed-dependent blower reduction, which reduces the air conditioner's flow noises at low speed. In cooling mode, this is compensated by lowering the vent temperature and by raising the ventilation temperature in heating mode.

Climatronic control panel



S339_076

To prevent the windscreen from misting when the compressor is switched off and the windscreen wipers are switched on, the defrost flap is automatically opened further to conduct more air to the windscreen.

Heated windscreen

Interior temperature sensor

Indirect ventilation

2C-Climatronic is equipped with indirect ventilation. An adapter positioned on the top of the air conditioner unit enables air distribution between the vents in the centre of the dash panel and indirect ventilation via the electrically driven air flap for indirect ventilation. This flap is actuated by the indirect ventilation flap control motor V213, which is initialised by the Climatronic control unit. The potentiometer for the indirect ventilation flap control motor G330 is integrated into the control motor. This records the flap position.

- After reaching the desired temperature in Climatronic automatic mode, the air flap in the indirect ventilation adapter is automatically switched from the air duct for the vents in the centre of the dash panel to the indirect ventilation air duct.
- In manual mode, indirect ventilation can be initialised by pressing the "arrow up" button on the air conditioner control panel.

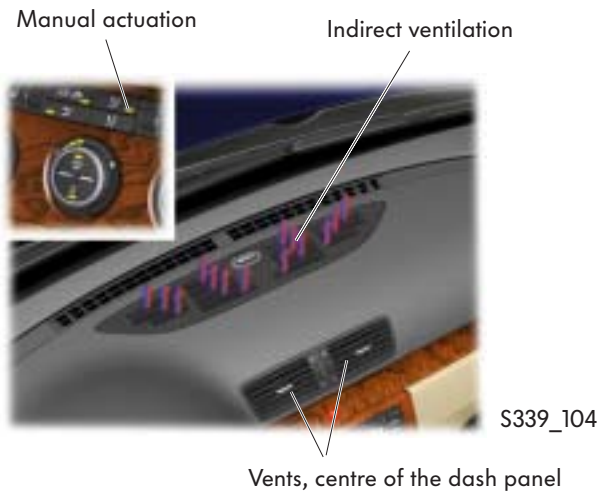

Indirect ventilation adapter

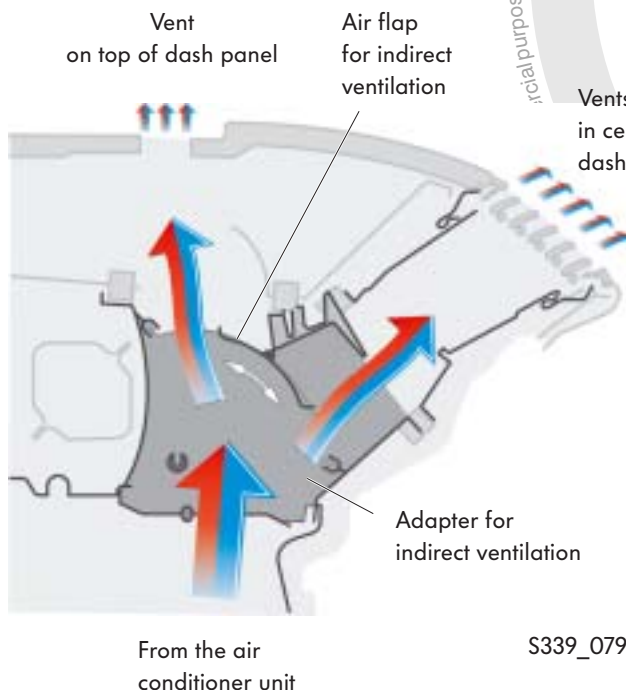
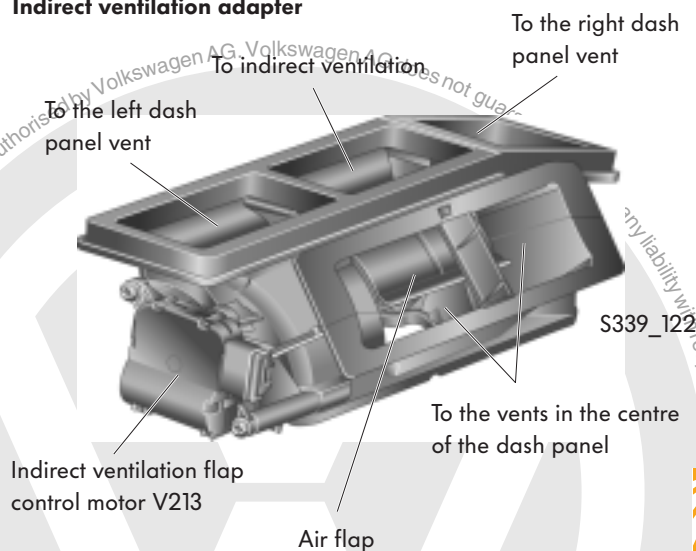

The flow pattern

The air coming from the air conditioner unit is forwarded in the indirect ventilation adapter depending on the position of the air flap:

- to the vents in the centre of the dash panel for direct ventilation and
- to the vents on the top of the dash panel for indirect ventilation



Information in this document: Copyright by Volkswagen AG. Copying is not permitted without the express written permission of Volkswagen AG.

any liability with respect to the content of this document is excluded.

Information in this document: Copyright by Volkswagen AG. Copying is not permitted without the express written permission of Volkswagen AG.

any liability with respect to the content of this document is excluded.

Information in this document: Copyright by Volkswagen AG. Copying is not permitted without the express written permission of Volkswagen AG.

any liability with respect to the content of this document is excluded.

Heater and air conditioner

The Thermo Top V auxiliary heater

The new Passat can be fitted with the optional Thermo Top V auxiliary coolant heater. The auxiliary heater is installed in the front right wing below the headlight.

This undertakes the following tasks:

- Acts as an auxiliary heater for heating the vehicle interior and defrosting the vehicle's windows
- Acts as stationary ventilation to lower the interior temperature when the vehicle is parked in the sun
- Acts as an additional heater in vehicles with petrol or diesel engines (fitted as standard in diesel engines)



S339_106

Thermo Top V auxiliary coolant heater

Radio remote control for auxiliary coolant heater



For basic information on auxiliary coolant heaters, please refer to self-study programme 280 "The Phaeton – auxiliary coolant heater and additional heater Thermo TOP C".

Structure

- The auxiliary coolant heater control unit is integrated into the heater unit. The electrical contacts for the combustion air blower are inserted directly into the control unit.
- The auxiliary coolant heater is fitted with a second NTC temperature sensor for controlling and monitoring the water temperature.
- The combustion air enters the combustion chamber via a venturi nozzle and thereby draws in the fuel delivered by the metering pump from the fuel line.

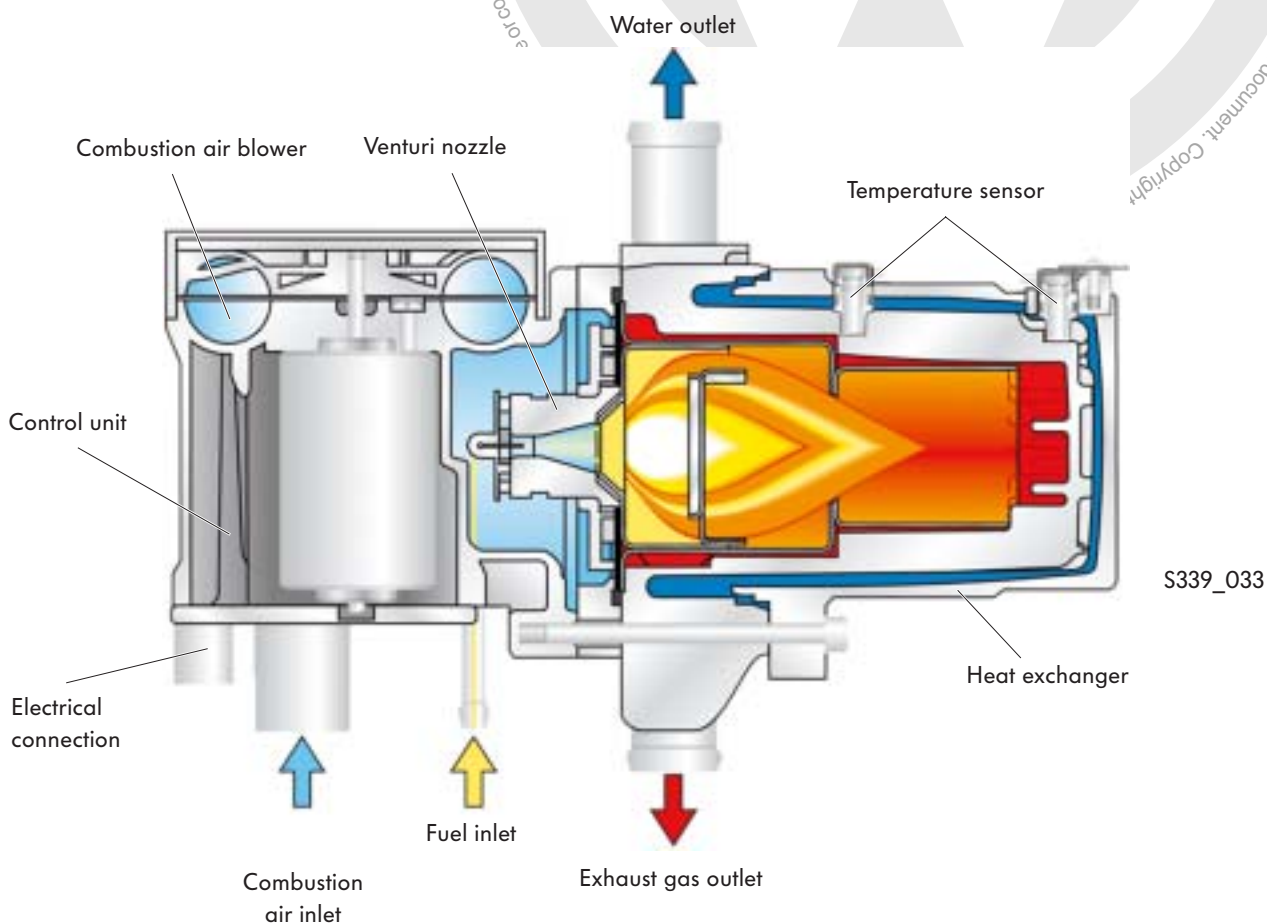

The venturi nozzle

The intaken air is guided through a ceramic housing, which is shaped as a venturi nozzle. As a result of this, the air delivered by the combustion air blower is accelerated to approx. 50 m/s. The incoming fuel is therefore drawn from the fuel line and swirled.



For information on fuel pre-heating and Thermo Top V activation, refer to self-study programme 318 "The Golf 2004".



Radio and navigation

The radio systems in the Passat 2006

Radio RCD 300

Radio RCD 300 is available as the standard radio system for private customers.

It offers the following functions:

- Two or four loudspeaker channels (20 Watts each)
- RDS FM/AM European radio (AM without LW)
- Indication of the stored stations with RDS names in the display
- FM 2-tuner diversity
- Control via the multi-function steering wheel (MFL) and multi-function indicator (MFI)
- Integrated single-CD player
- Control system for external 6-fold CD-changer
- Telephone control system (hands-free)
- GALA
- Self-diagnosis with loudspeaker diagnosis
- Transport mode
- Driving school function (indication of turn signal function and speed via the display)



S339_070

Radio RCD 500

Radio RCD 500 in the Passat 2006 offers the following functions:

- Four loudspeaker channels (20 Watts each)
- RDS FM/AM European radio (AM without LW)
- Indication of the stored stations with RDS names in the display
- FM 2-tuner phase diversity
- Control via the MFL and MFI
- Integrated single-CD player
- Control system for external 6-fold CD-changer
- Telephone control system (hands-free)
- GALA
- Traffic Information Memory (TIM)
- Vehicle model-specific sound adaptation
- Self-diagnosis with loudspeaker diagnosis
- Transport mode
- Optional connection of an external sound amplifier



S339_071

Radio/navigation system MFD 2

A radio system with an integrated navigation system is also available for the Passat 2006.

The operating sequences are similar to those of the radio/navigation system fitted in the Touareg.

It offers the following functions, etc.:

- Multi-colour display (MFD)
- Dynamic guidance
- Four loudspeaker channels (20 Watts each)
- RDS FM/AM European radio (AM without LW)
- Indication of the stored stations with RDS names in the display
- External diversity changeover box
- Control via the MFL and MFI
- Control system for external 6-fold CD-changer
- Telephone control system (hands-free)
- GALA
- TIM
- Self-diagnosis with loudspeaker diagnosis



S339_072



The cover frame has to be removed to remove or install a radio, in order to access the threaded connection located behind it.



For further information on radios, please refer to self-study programme 342 "Radio systems".



Notes







PASSAT



© VOLKSWAGEN AG, Wolfsburg
All rights and technical changes reserved.
000.2811.54.20 Technical status 03.2005

Volkswagen AG
Service Training VK-21
Brieffach 1995
D-38436 Wolfsburg

 This paper has been manufactured from cellulose bleached without the use of chlorine.