

Service.



Self-study programme 311

The Transporter 2004 Electrical system

Design and function



The Transporter 2004 has an extensive network of electronic control units.

Functions which were controlled in the predecessor model switches and relays are controlled digitally via the drive train CAN data bus and the convenience CAN data bus systems.

The formerly mechanical opening of the sliding door is now controlled electrically. There are many other functions which also represent modifications to the predecessor model.

This Self-Study Programme will give you a better understanding of the innovations to the electrical system of the Transporter 2004.

This will ensure that, as before, you are able to provide customer satisfaction through technical competence.



S311_121



NEW



Important Note

This Self-Study Programme shows the design and function of new developments. The contents will not be updated.

Please refer to the relevant service literature for current inspection, adjustment and repair instructions.

Contents



Copyright: Copying for private or commercial purposes, in part or in whole, is not permitted unless authorised by Volkswagen AG. Volkswagen AG does not guarantee or accept any liability with respect to the correctness of information in this document.

| | |
|----------------------------------------------------------|-----------|
| Introduction | 4 |
| The CAN data bus | 4 |
| Onboard power supply | 8 |
| The fitting locations of the electrical components | 8 |
| The onboard power supply control unit | 16 |
| The control unit with display in dash panel insert | 40 |
| The electrical tachograph | 43 |
| Comfort and safety electronics | 44 |
| The convenience system central control unit | 44 |
| The anti-theft alarm system | 50 |
| The electrically operated sliding door | 54 |
| The multi-function steering wheel | 60 |
| The cruise control system (CCS) | 64 |
| Radio/telephone/navigation | 66 |
| The radio systems | 66 |
| Digital Voice Enhancement DVE | 72 |
| The amplifier | 76 |
| The aerial systems | 88 |
| Air conditioning system | 82 |
| Service | 84 |
| Test yourself | 86 |



Introduction

The CAN data bus

Data bus network

The control units of the Volkswagen Transporter are connected to each other via the CAN data bus network.

The network makes it possible to exchange data between the control units.

Information is sent via the CAN data bus in digital form instead of via discrete cable connections.

This makes it possible for other control units to access the information.

The CAN data bus is split into two single systems, the drive train CAN data bus and the convenience CAN data bus.

Both bus systems are connected to each other via the data bus diagnosis interface (Gateway) J533 in the dash panel insert and this allows the exchange of data.

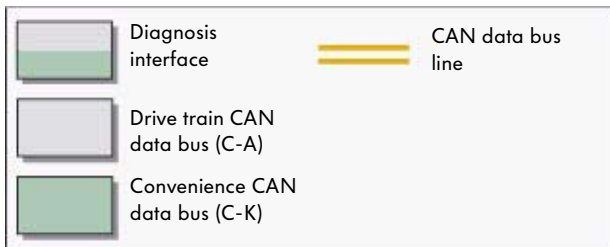
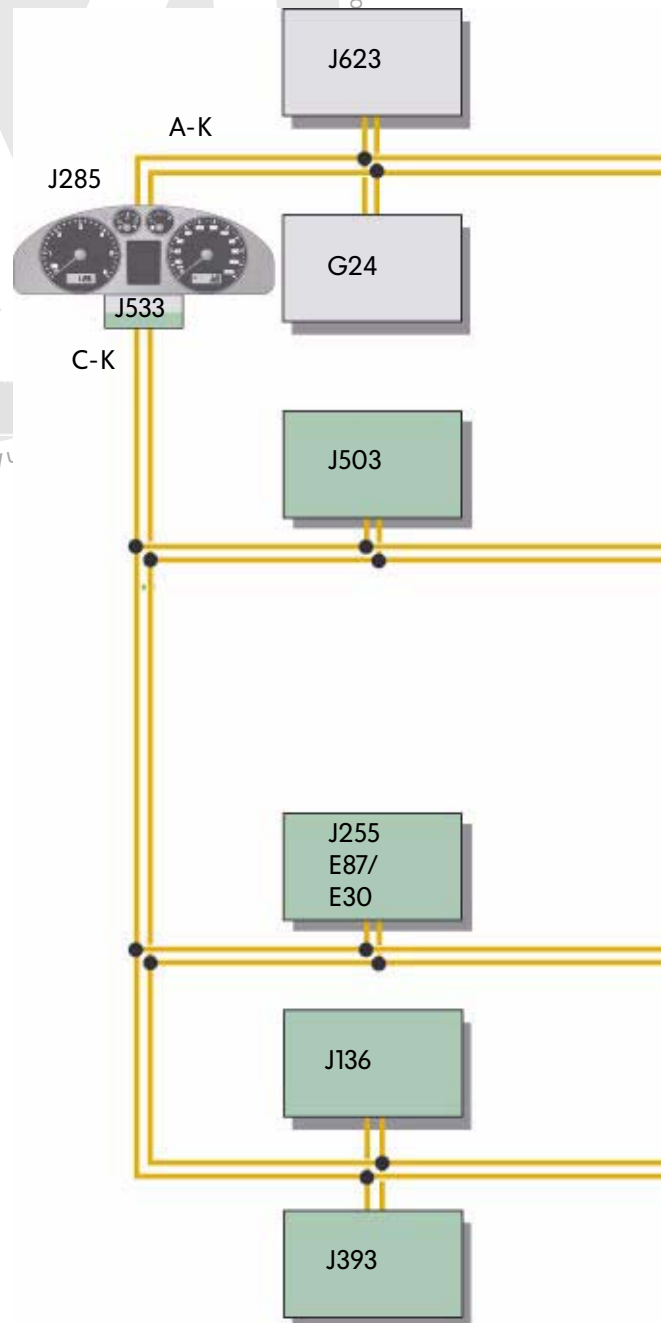

S311_113

permitted unless authorised by Volkswagen AG. Volkswagen AG does not warrant or accept liability for the use of this information.

Legend

- G24 Tachograph
- G85 Steering angle sender
- E30 Air conditioner switch
- E87 Air conditioning system/Climatronic operating and display unit
- E265 Rear Climatronic operating and display unit
- J104 ABS with EDL control unit
- J136 Seat adjustment control unit with memory function
- J162 Heater control unit
- J217 Automatic gearbox control unit
- J234 Airbag control unit
- J255 Climatronic control unit
- J285 Control unit with display in dash panel insert
- J386 Door control unit, driver side
- J387 Door control unit, front passenger side
- J393 Central convenience system control unit
- J412 Operating electronics control unit, mobile telephone
- J453 Multi-function steering wheel control unit
- J492 Four-wheel drive control unit
- J503 Radio and navigation control unit with display unit
- J519 Onboard electrical system control unit
- J533 Data bus diagnosis interface
- J558 Sliding door control unit
- J623 Engine control unit
- J656 Voice enhancement control unit
- J702 Roof display unit
- J731 Right sliding door control unit
- R radio:
(Delta radio only, not in commercial vehicles)
- R12 Amplifier
- R78 TV tuner

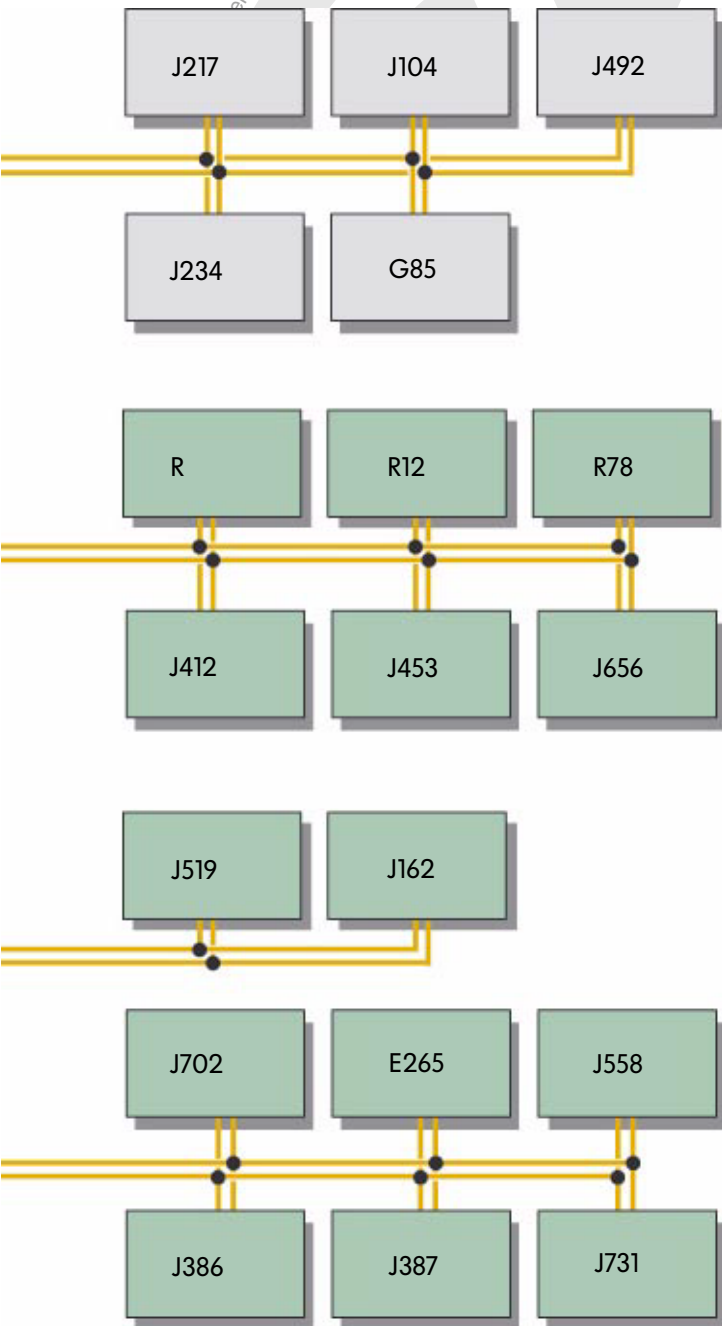

S311_001

Introduction

The drive train CAN data bus (C-A)

All control units assigned to the drive train

are connected to each other via the drive train CAN data bus.

The data transfer rate is 500 kbit/s. Data is transmitted along the CAN high and CAN low lines.

The drive train CAN data bus only has ready status if both data lines are intact.

In case of failure of a data line, an open circuit or a short circuit, no data transfer takes place.

A fault is entered into the fault memories of the participating control units.

The CAN data bus lines are colour-coded orange/black for the CAN high line and orange/brown for the CAN low line. The lines are twisted together.

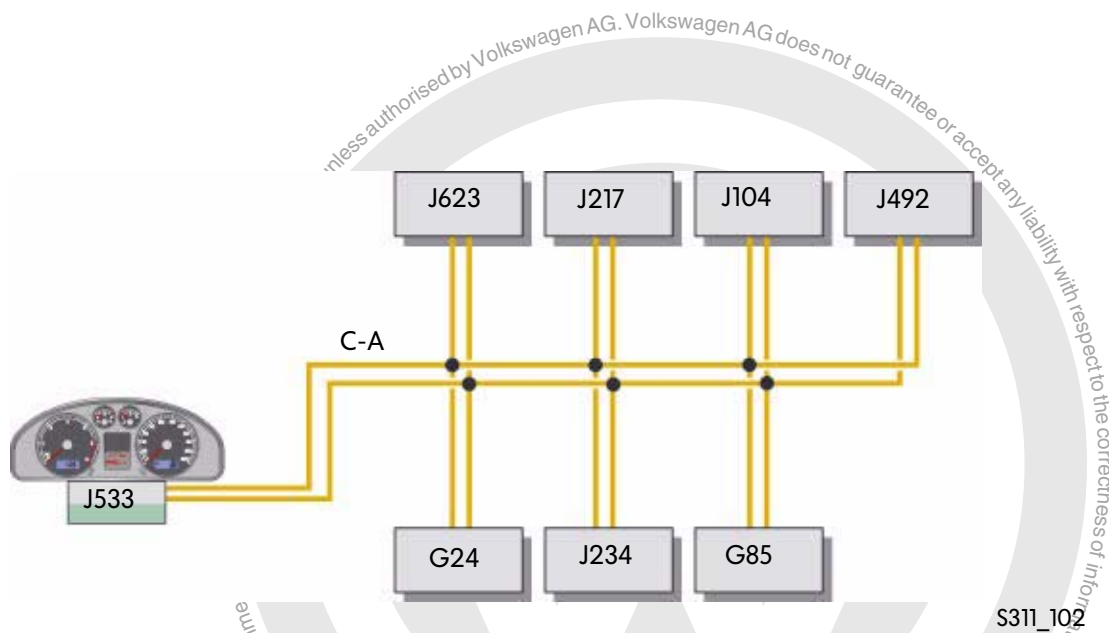

Legend

| | |
|------|--------------------------------|
| G24 | Tachograph |
| G85 | Steering angle sender |
| J104 | ABS with EDL control unit |
| J217 | Automatic gearbox control unit |
| J234 | Airbag control unit |
| J492 | Four-wheel drive control unit |
| J533 | Data bus diagnostic interface |
| J623 | Engine control unit |



You can find further information on the CAN data bus in SSP 186, entitled "The CAN data bus" and in SSP 238, entitled "Data exchange on the CAN bus".

The convenience CAN data bus (C-K)

Control units not assigned to the drive train are connected to each other via the convenience CAN data bus.

The data transfer rate is 100 kbit/s. Data is transmitted along the CAN high and CAN low lines.

The convenience CAN data bus has ready status even if a data line is not intact.

In case of failure of a data line, an open circuit or a short circuit, data is still transferred across the remaining data line (single-wire mode).

If a short circuit occurs, a fault will be entered into the fault memories of the participating control units.

The CAN high line is orange/green, the CAN low line is orange/brown.

The lines are twisted together.

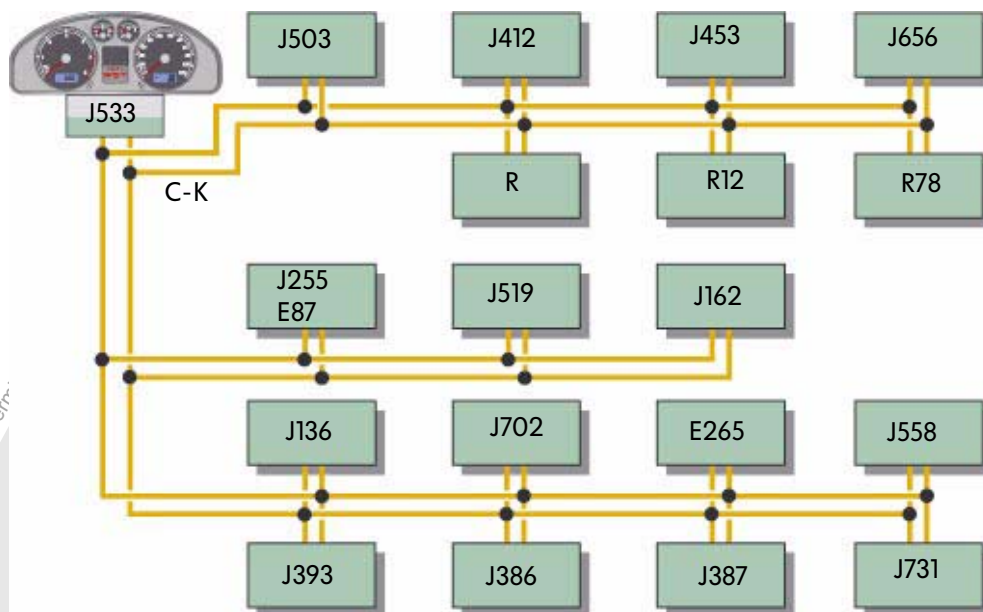

S311_103

Legend

- | | | | |
|------|----------------------------------------------------------------------|------|----------------------------------------------------|
| E87 | Air conditioning system/Climatronic operating and display unit | J503 | Control unit with display for radio and navigation |
| E265 | Rear Climatronic operating and display unit | J519 | Onboard power supply control unit |
| J162 | Additional heater control unit | J533 | Data bus diagnosis interface |
| J136 | Seat adjustment control unit memory function (not for market launch) | J558 | Sliding door control unit |
| J255 | Climatronic control unit | J656 | Voice enhancement control unit |
| J386 | Door control unit, driver side | J702 | Roof display unit |
| J387 | Door control unit, front passenger side | J731 | Right sliding door control unit |
| J393 | Convenience system central control unit | R | Delta radio |
| J412 | Mobile telephone operating electronics control unit | R12 | Amplifier |
| J453 | Multi-function steering wheel control unit | R78 | TV tuner |

Onboard power supply

Fitting locations of the electrical components

Overview of the fitting locations in the onboard power supply

The fuse holder, relay positions and connector stations are fitted at different locations in the vehicle.

10-socket connector stations

The connector station is located:
on D-pillar on the left
on D-pillar on the right

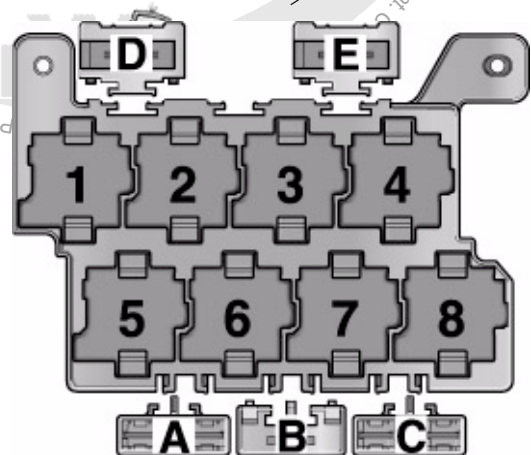
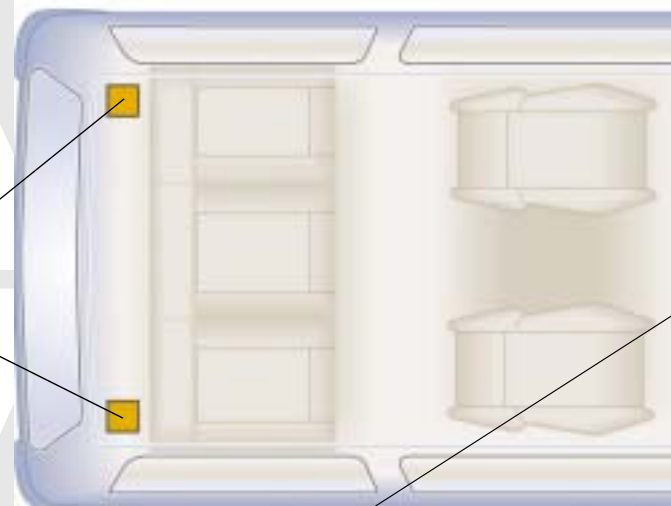
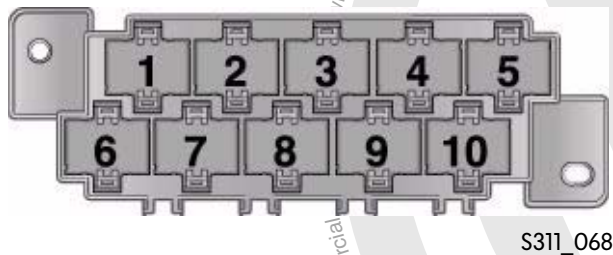

8-socket relay holder

The relay holder is located in the seat base on the left.

... is not permitted unless authorised by Volkswagen AG. Volkswagen AG does not guarantee or accept any liability with respect to the correctness of information.

10-socket connector stations

The connector stations are located:
 on A-pillar on the left
 in the seat base on left
 in the seat base on right

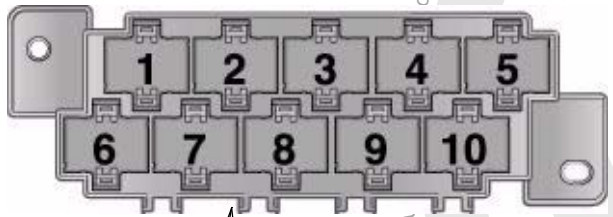

S311_068

Electronics box

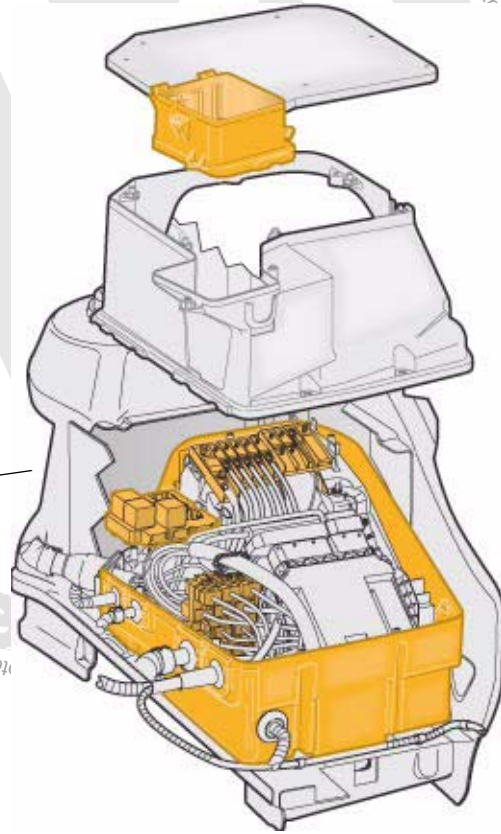

S311_005

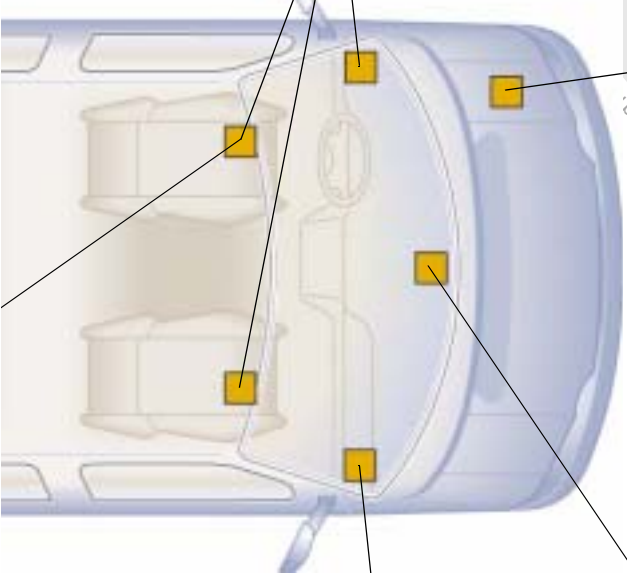

S311_003

8-socket relay holders (1 and 2)

The relay holder are located under the dash panel,
 in the centre

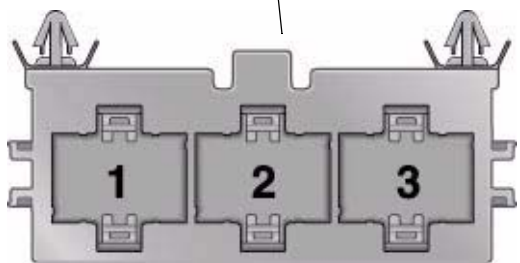

S311_070

3-socket connector station

The connector station is located on the
 A-pillar at the right.

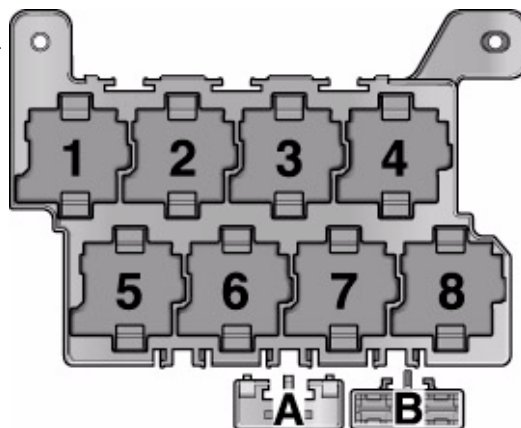

S311_066

Onboard power supply

Electronics box

The electronics box is located in the engine compartment, on the left in the direction of travel. It accommodates the fuses for the engine compartment, the engine control unit J623 and the automatic gearbox control unit J217.

It consists of a watertight housing and allows the serviceable installation of the control units.

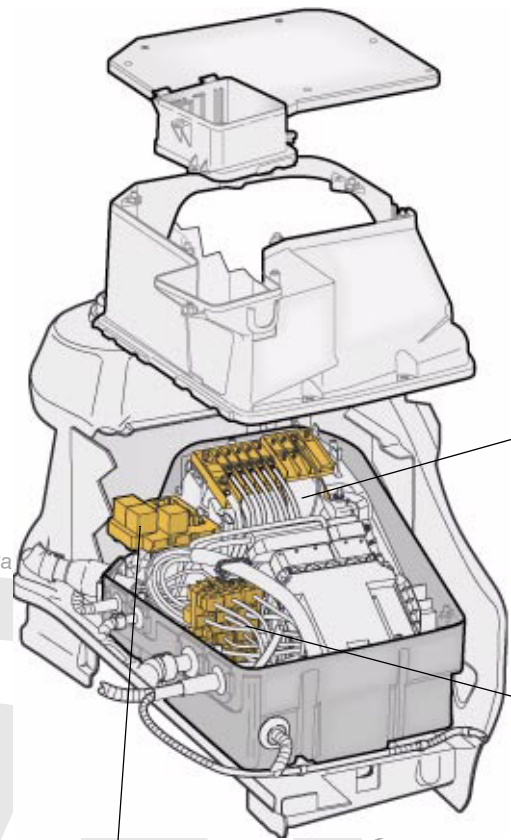

S311_104

9-socket relay holder

The relay holder is located in the engine compartment in the electronics box.

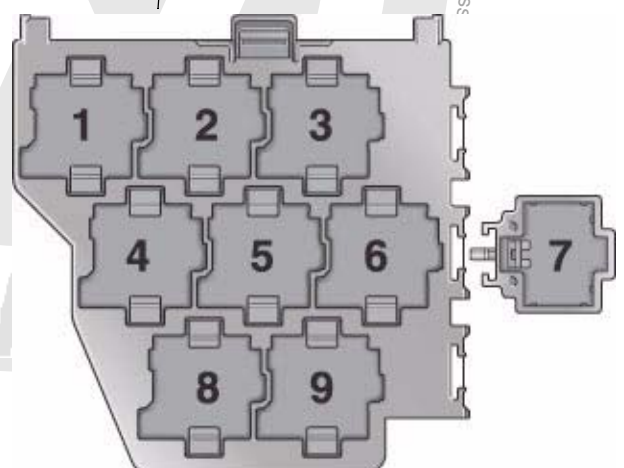

S311_051

Main fuse holder

The main fuse holder is located in the engine compartment in the electronics box.

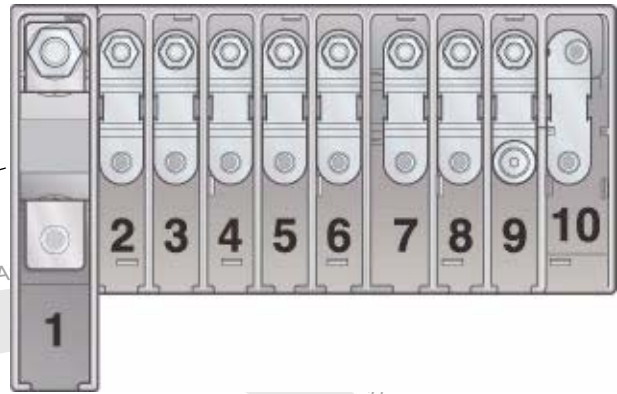

S311_049

15-socket connector station

The connector station is located in the engine compartment in the electronics box.

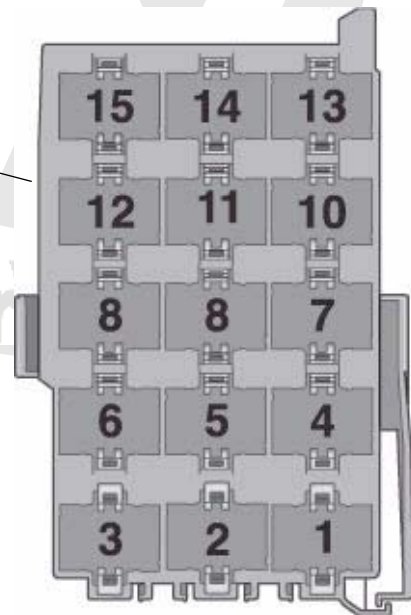

S311_052

Onboard power supply

Service port

A service port allows fuses to be replaced without having to remove the complete housing.

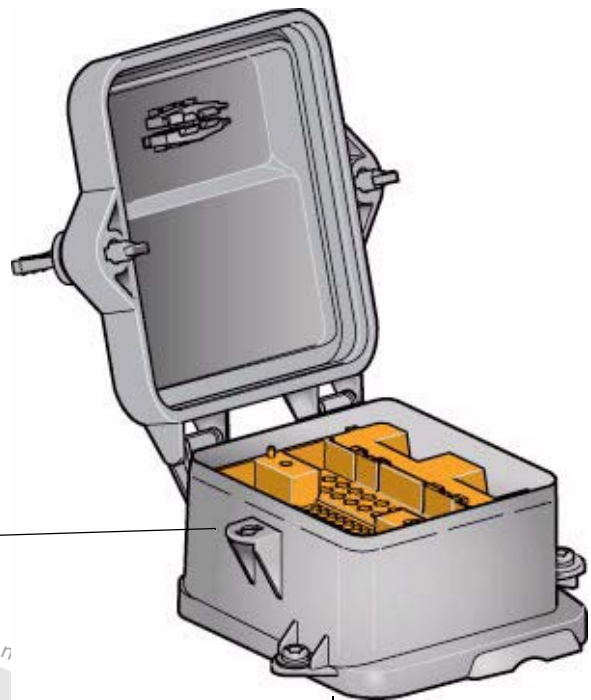

S311_004

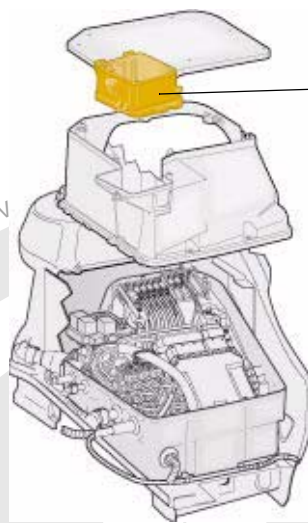

S311_105

Fuse holder for SD fuses

The fuse holder is also located in the engine compartment in the electronics box. It can be accessed through the service port.

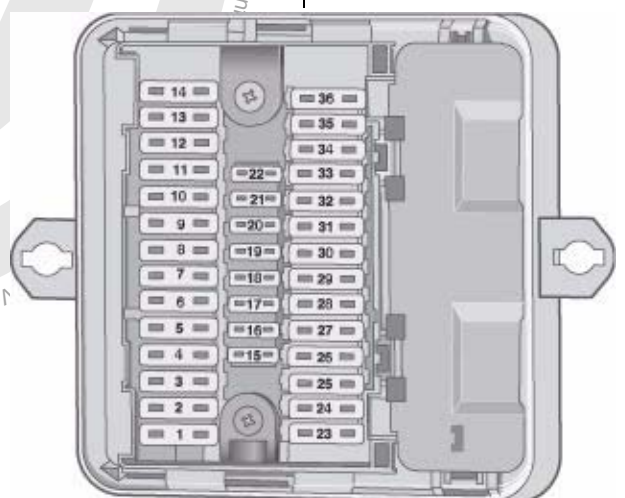

S311_050

Fuse holder for SC fuses

The fuse holder is located in the centre of the vehicle below the dash panel and is covered by a trim panel.

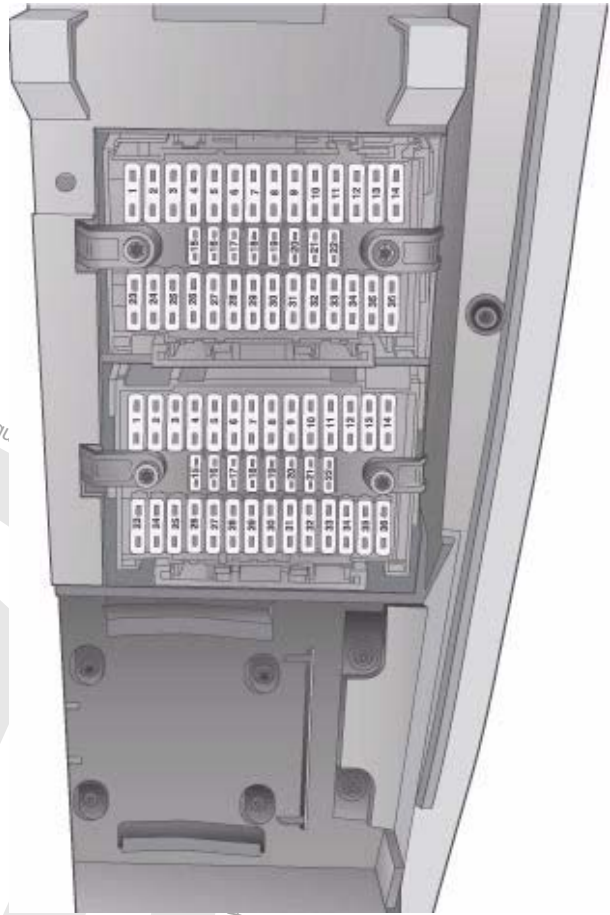

S311_053

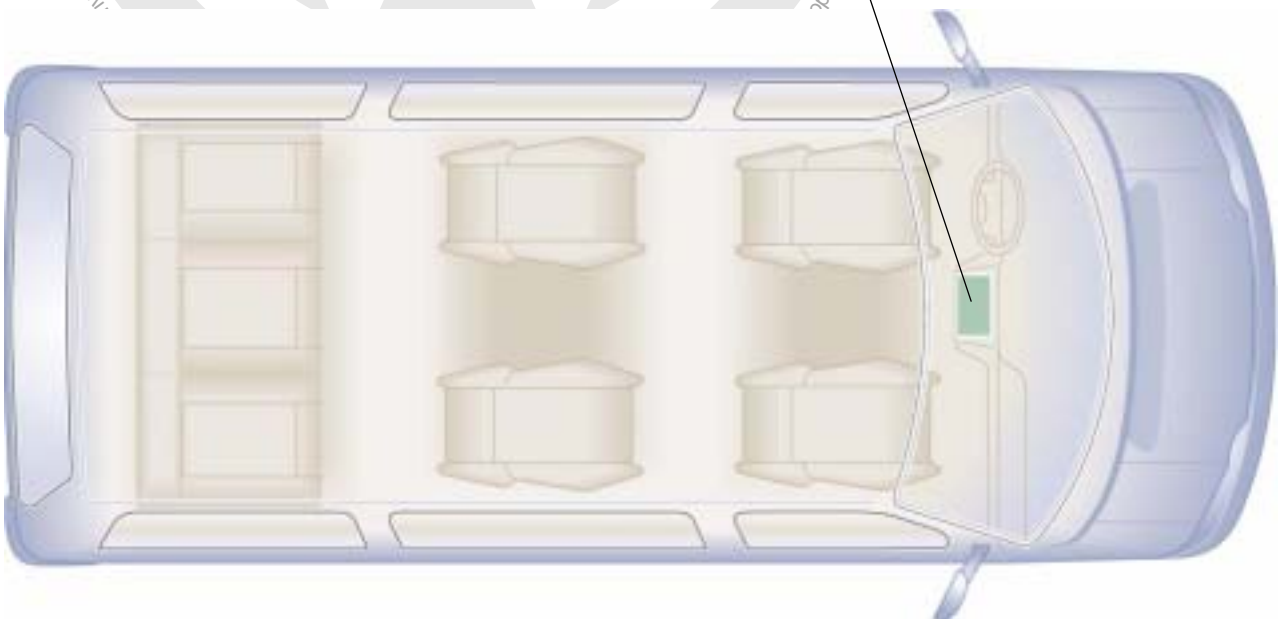

S311_056

Onboard power supply

Fitting locations of the control units

The control units are fitted at different locations in the vehicle.

Door control unit, driver side J386
in the door on the left



Sliding door control unit
J558
on D-pillar on left

Right sliding door control unit
J731
on D-pillar on right

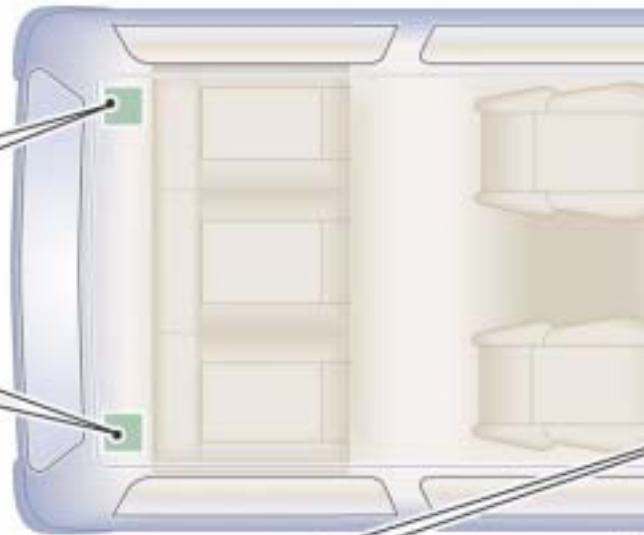

Voice amplification control units J656
on right under seat base

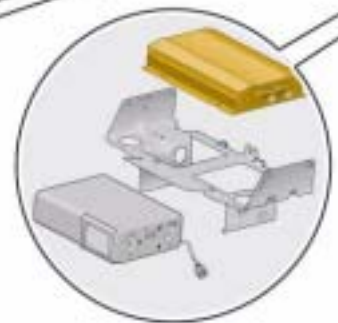

Voice amplification control units J656
on right under seat base

Onboard electrical supply control unit J519 on left under dash panel

Engine control unit J623 in electronics box in engine compartment

Automatic gearbox control unit J217 in electronics box in engine compartment

Parking aid control unit J446 on right under dash panel

Auxiliary heater radio receiver R84 on right under dash panel

Convenience system central control unit J393 on the right seat base (under the front passenger seat in direction of travel on left-hand side)

Door control unit, front passenger side J387 in door on right

S311_002

Onboard power supply

The onboard power supply control unit J519

Combined in the onboard power supply control unit are functions of relays/control units which were previously executed by various relays/control units located at different positions.

This has the following advantages:

- easier assembly
- less electrical wiring
- fewer connectors
- lower costs
- quick fault-finding through diagnosis

The onboard power supply control unit can exchange data with the other control units in the vehicle via the convenience CAN data bus.

Fitting location

The onboard power supply control unit is located below the dash panel on the left.

Variants

The onboard power supply control unit is available in the following variants:

- Basis Low
- Basis
- Medium/Midline
- High end/Highline

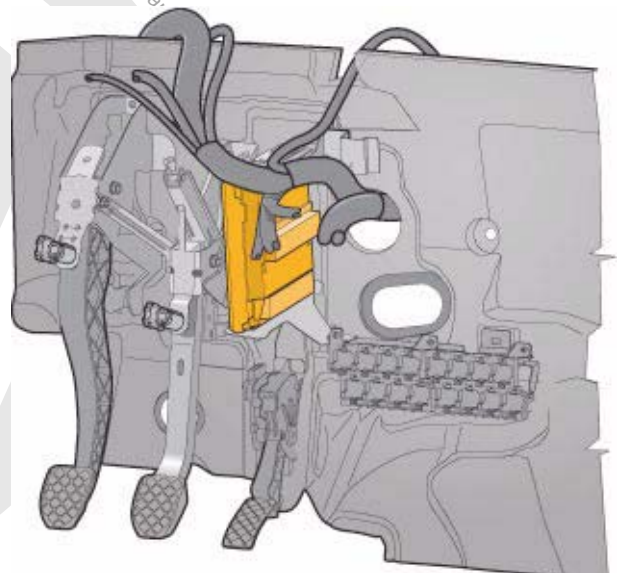

S311_008



The following function charts provide an overview of the input and output signals as well as the signal paths. Under no circumstances do they replace the valid current flow diagram. For fault-finding and repair, always use the Vehicle Diagnosis, Testing and Information System VAS 5051 and the Electronic Service Information System (ELSA).

Tasks

The onboard power supply control unit controls and switches the following functions:

- Turn signal control
- Windscreen wiper motor actuation
- Activation of the heated rear window
- Control of the alternator pre-excitation via terminal "L"
- Activation of the interior lighting
- Activation of the heated exterior mirror
- Control of the function enable for the sliding sunroof and the window regulator
- Activation of the battery isolation relay
- Control of the starter inhibitor
- Activation of the reversing lights
- Switch and instrument light regulation
- Control of electrical fuel pump feed
- Electrical load management control
- Recognition of switch positions on the cruise control system
- Control of the Shift-Lock function in vehicles with automatic gearbox
A driving range can only be selected if the foot brake is applied.
- Recognition of the positions of the central locking switches of all doors and bonnet contact switch F266 and output to the CAN data bus
- Recognition of the states of terminals S, 15, X and 50 and output to the CAN data bus
- Activation of the heated windscreen
- Control of the dual tone horn
The signal from horn plate H is read in by the onboard power supply control unit, and the dual tone horn is directly activated from here.



The following legend applies to all function diagrams below.

- Signal output
- Earth
- Signal output
- Positive
- CAN data bus line

Onboard power supply

The turn signal control

Functional description

The turn signal function is executed in the onboard power supply control unit. The flashing lights are activated depending on the input signals from the turn signal switch. The turn signal frequency is controlled by the onboard power supply control unit. The turn signal operation always begins with a bright phase.

Turn signal warning lamps

The left and right turn signal warning lamps K65 and K94 in the control unit with display in the dash panel insert are activated via the convenience CAN data bus. The warning lamps flash at the same frequency as the flashing lights.

Motorway hazard warning light function

If the turn signal switch is operated only briefly (flicked), the flashing lights will flash three times.

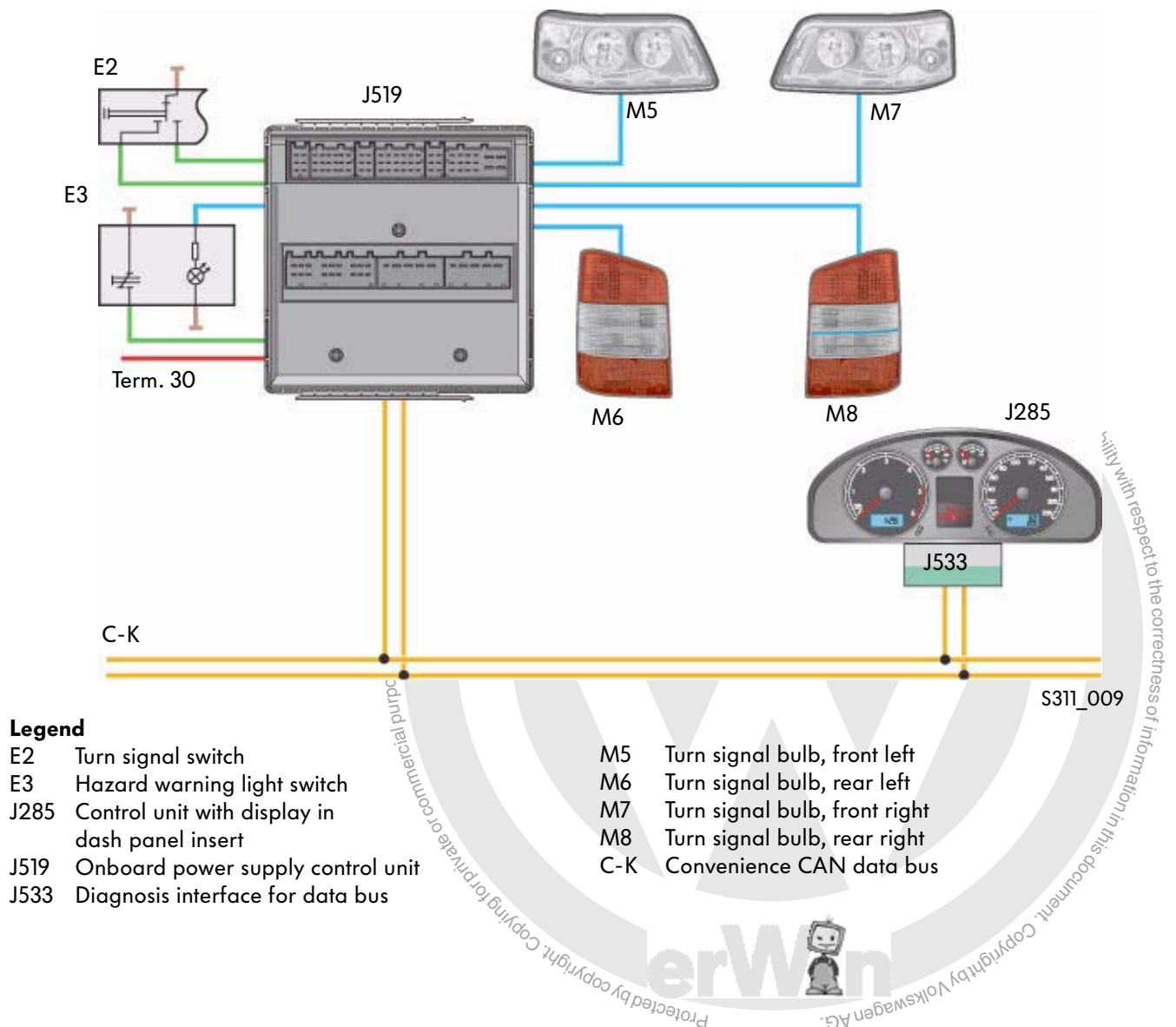

Legend

- E2 Turn signal switch
- E3 Hazard warning light switch
- J285 Control unit with display in dash panel insert
- J519 Onboard power supply control unit
- J533 Diagnosis interface for data bus

- M5 Turn signal bulb, front left
- M6 Turn signal bulb, rear left
- M7 Turn signal bulb, front right
- M8 Turn signal bulb, rear right
- C-K Convenience CAN data bus

Description of the hazard warning function

The hazard warning function is executed in the onboard power supply control unit.

The flashing lights are activated depending on the input signals from the hazard warning light switch E3. The turn signal frequency is controlled by the onboard power supply control unit.

The hazard warning function always begins with a bright phase.

Hazard warning light system warning lamps

The hazard warning light system warning lamp K6, as well as the left and right turn signal warning lamps K65 and K94 are activated.

The system is activated directly by the onboard power supply control unit via a pulse-width modulated signal.

There are two activation modes:

- activation depending on the set dim stage (for switch illumination).
- activation as a warning lamp when the warning light function is active. A flashing light is produced by switching between the min and max brightness levels.

Collision warning light function

The flashing-light collision warning function (activation of warning light in case of collision) is activated by the onboard power supply control unit. This control unit sends a corresponding signal from the airbag control unit via the drive train CAN data bus, the data bus diagnostic interface in the dash panel insert and the convenience CAN data bus.

To deactivate the function, the ignition (terminal 15) must be turned off and the hazard warning light switch operated.

Flasher function for anti-theft alarm system

The function "flash on activation of the anti-theft alarm system" is activated by the convenience system central control unit J393 via the convenience CAN data bus.

The function is not activated if the hazard warning light system or the turn signals are switched on.

Turn signal failure detection

If a turn signal fails, the flashing rate of the warning lamp will be doubled and the flashing lights will continue to flash at normal frequency. A bulb failure is not indicated when the hazard warning function is active.



To ensure proper operation of the turn signal warning lamps, trailer operation must be encoded in the onboard power supply control unit. For encoding, use the Vehicle Diagnosis, Testing and Information System VAS 5051 and the Electronic Service Information System (ELSA).

Onboard power supply

Windscreen wiper motor actuation

Functional description

The wiper switch signals are evaluated directly by the onboard power supply control unit. The selected function for windscreen wiper motor activation is executed via the onboard power supply control unit.

Function diagram of windscreen wiper motor actuation

Flick wipe

When the "Flick wipe" function is activated, terminal 53 (stage 1) of the windscreen wiper motor is energised. After the function is deactivated, wiping continues until the wiper reaches its rest position.

Wipe stage 1

When the "Wipe stage 1" function is activated, terminal 53 (stage 1) of the windscreen wiper motor is energised. Wipe stage 1 is maintained if the vehicle comes to a standstill. After the function has been deactivated, wiping continues until the wiper reaches its rest position.

Wipe stage 2

When the "Wipe stage 2" function is activated, terminal 53b (stage 2) of the windscreen wiper motor is energised. Wipe stage 2 is maintained if the vehicle comes to a standstill. After the function has been deactivated, wiping continues until the wiper reaches its rest position.

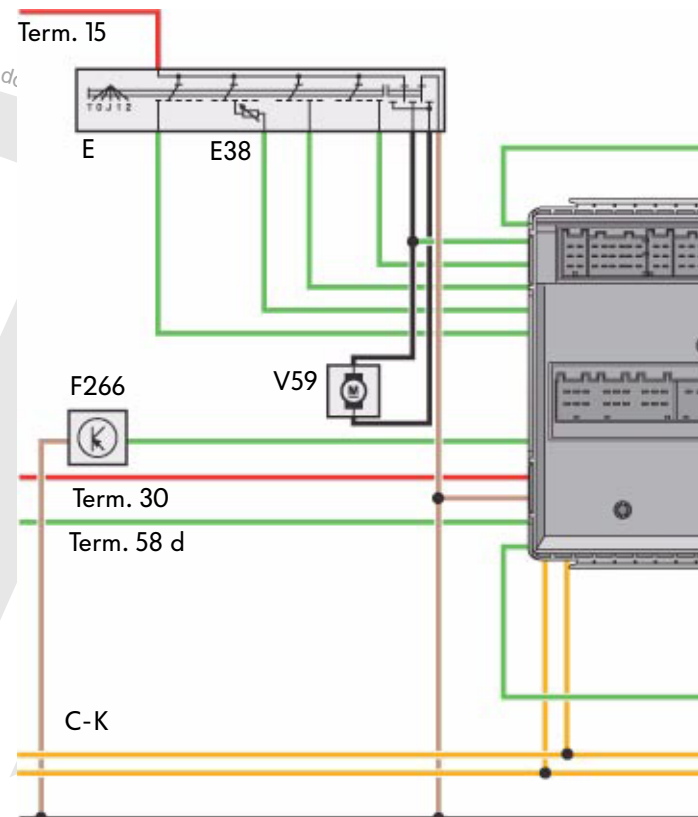

Legend

- E Windscreen wiper switch
- E38 Intermittent wiper control
- F229 Windscreen wiper limit switch
- F266 Bonnet contact switch
- G213 Rain sensor

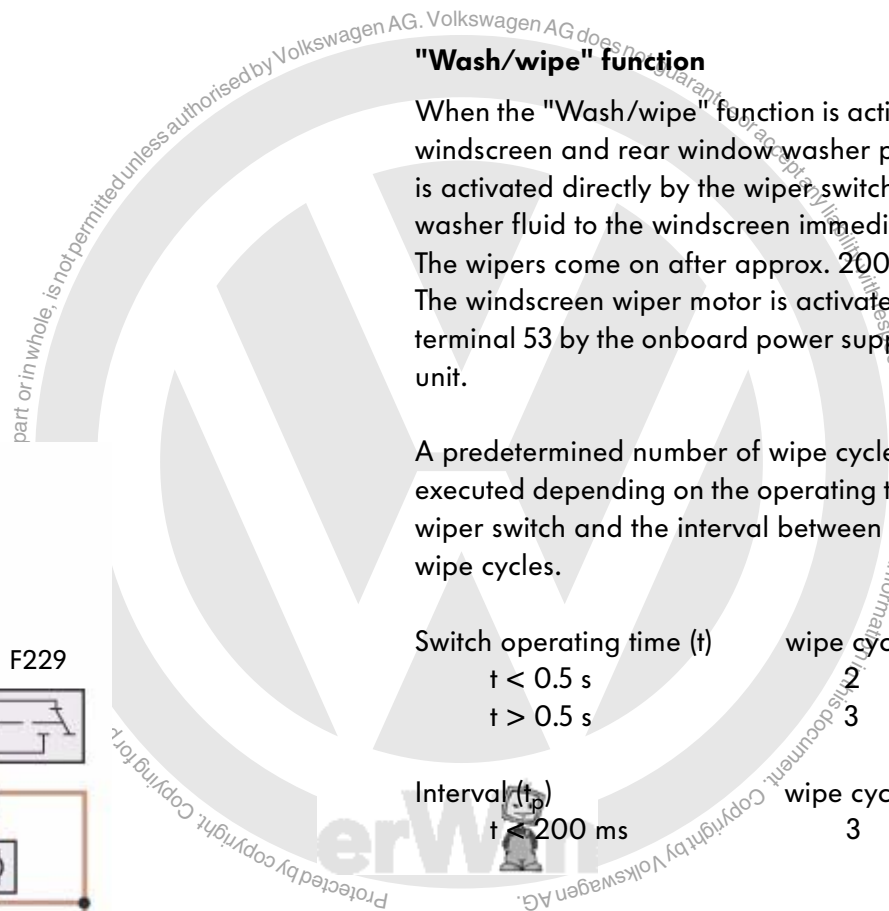

"Wash/wipe" function

When the "Wash/wipe" function is activated, the windscreen and rear window washer pump V59 is activated directly by the wiper switch; it feeds washer fluid to the windscreen immediately. The wipers come on after approx. 200 ms. The windscreen wiper motor is activated at terminal 53 by the onboard power supply control unit.

A predetermined number of wipe cycles is executed depending on the operating time of the wiper switch and the interval between two wash/wipe cycles.

| Switch operating time (t) | wipe cycles |
|-----------------------------|-------------|
| $t < 0.5 \text{ s}$ | 2 |
| $t > 0.5 \text{ s}$ | 3 |
| Interval (t_{B}) | wipe cycles |
| $t < 200 \text{ ms}$ | 3 |

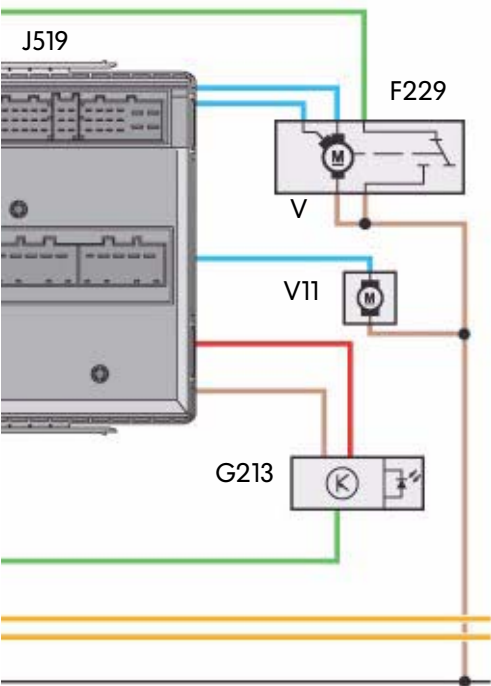

S311_010

Blocked motor detection

If no signal switchover is detected at the limit switch (terminal 31b) for 40 s during operation of the windscreen wiper motor, the onboard power supply control unit switches over to direct activation by the wiper switch.

The windscreen wiper motor can be switched off in any position.

- J519 Onboard power supply control unit
- V Windscreen washer motor
- V11 Headlight washer system pump
- V59 Windscreen and rear window washer pump
- C-K Convenience CAN data bus

Onboard power supply

Headlight washer system

When the light is on, the headlight washer system pump V11 is activated in the "Wash/wipe" function in addition to the windscreen and rear window washer pump.

The headlight washer system pump is activated approx. 1500 ms after the windscreen and rear window washer pump is activated. The duration of the wash cycle is approx. 700 ms.

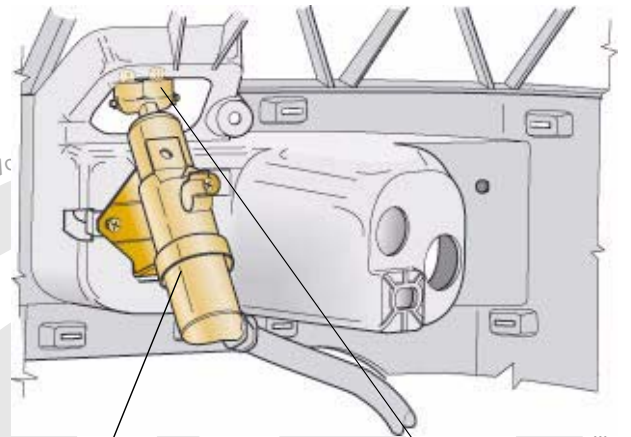

Lifting cylinder

Nozzle support

S311_106

Speed dependent intermittent delay

If no rain sensor is installed in the vehicle, the intervals in intermittent mode are controlled depending on the road speed and the adjustment of the intermittent wiper control E38.

When an elevated, higher sensitivity is set, a wipe operation is triggered immediately. When a lower sensitivity is set, no wipe operation is triggered.

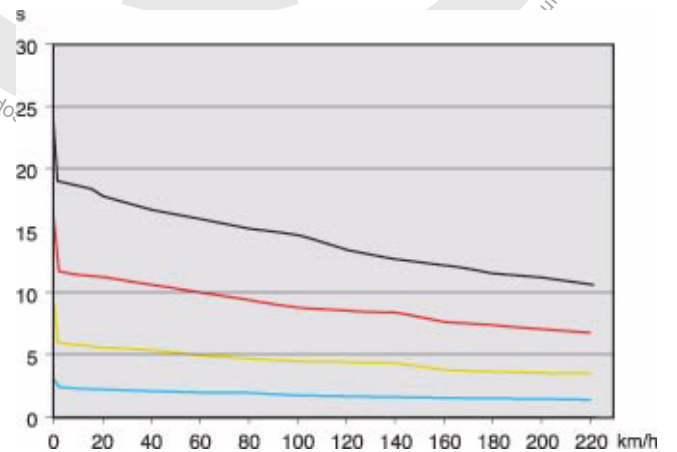

S311_011

- 1st stage
- 2nd stage
- 3rd stage
- 4th stage

Rain sensor dependent intermittent wiper control

The Volkswagen Transporter can be optionally equipped with a rain sensor.

The rain sensor is mounted on the windscreen. Its signals are evaluated by the onboard power supply control unit.

The rain sensor is activated at terminal 15 (ignition "on") and with the windscreen wiper switch in the "Intermittent" position. If the "Intermittent" stage is already active when the ignition is turned on, then the ignition must be switched off and on again in order to activate the rain sensor.

The rain sensor emits a light signal via an LED. Depending on the state of the windscreen (dry or wet), this light signal is reflected to a greater or lesser extent.

A photo diode receives this reflected signal. The electronics of the rain sensor convert the signal to a voltage signal and transmit it to the onboard power supply control unit. The onboard power supply control unit evaluates the signal and controls the intermittent delay accordingly.

If the rain sensor fails, the intermittent delay is controlled as a function of road speed.

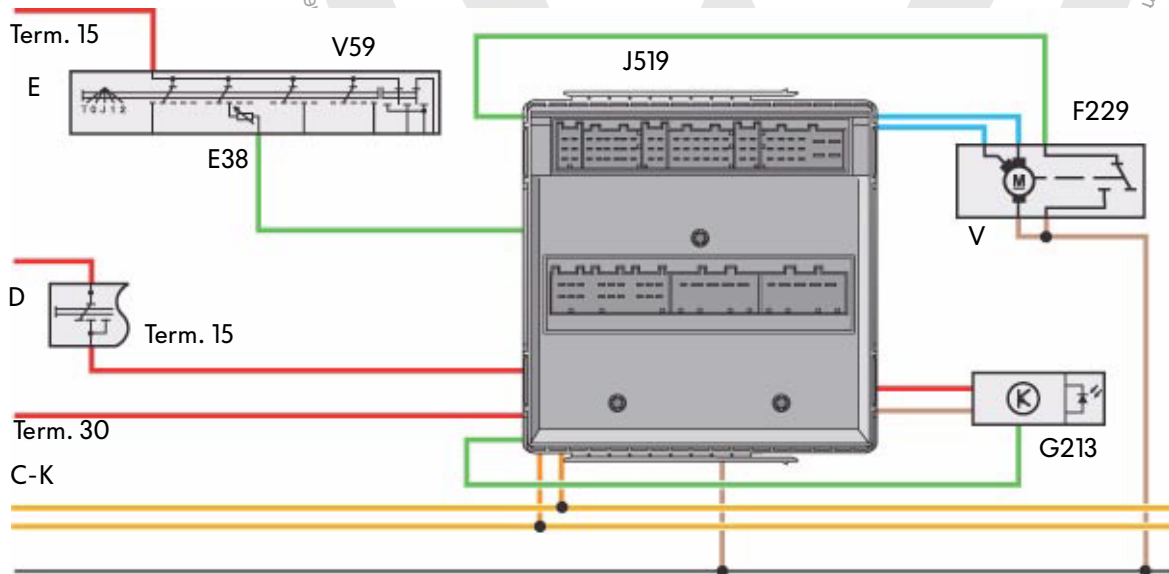

S311_012

Legend

| | | | |
|------|-------------------------------|------|-----------------------------------|
| D | Ignition switch | G213 | Rain sensor |
| E | Windscreen wiper switch | J519 | Onboard power supply control unit |
| E38 | Intermittent wiper control | V | Windscreen washer motor |
| E229 | Windscreen wiper limit switch | C-K | Convenience CAN data bus |

Onboard power supply

Activation of the heated rear window

Functional description

The onboard power supply control unit reads in the signal from the heated rear window button E230 and activates the heated rear window directly.

Activation conditions

- Alternator is charging and
- heated rear window button pressed

Deactivation conditions

- alternator is not charging or
- heated rear window button pressed again or
- automatic switch-off after maximum operating time of four minutes
- switch-off by the electrical load management system.

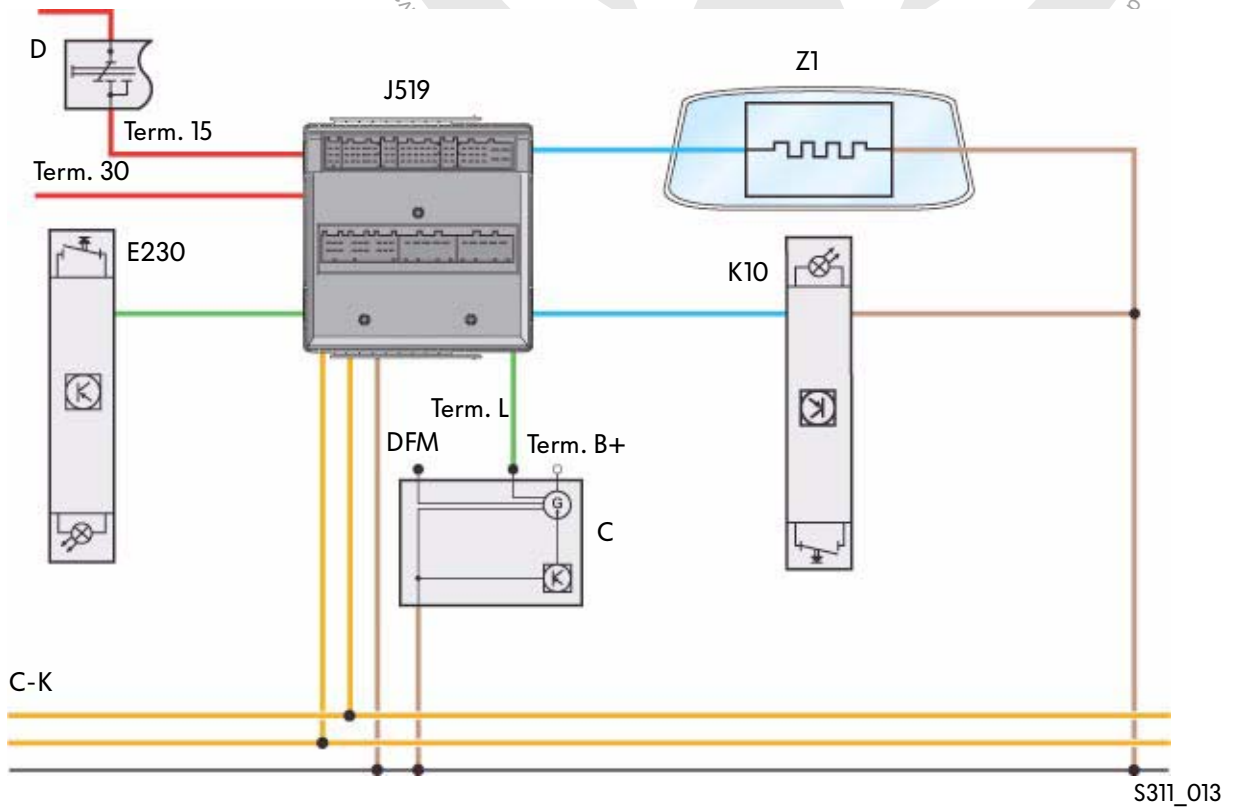

Legend

C 3-phase AC alternator
 D Ignition switch
 E230 Heated rear window button

J519 Onboard power supply control unit
 K10 Heated rear window warning lamp
 Z1 Heated rear window
 C-K Convenience CAN data bus

Control of alternator pre-excitation via terminal "L"

Functional description

To ensure that an alternator can generate the required power as soon as it starts up, the alternator must be pre-excited after terminal 15 is energised.

Pre-excitation is controlled by the onboard power supply control unit. Current flows via terminal L to the exciter winding in the alternator, thus building a magnetic field.

This magnetic field is required for power generation directly after the engine starts in order to ensure sufficient alternator output.

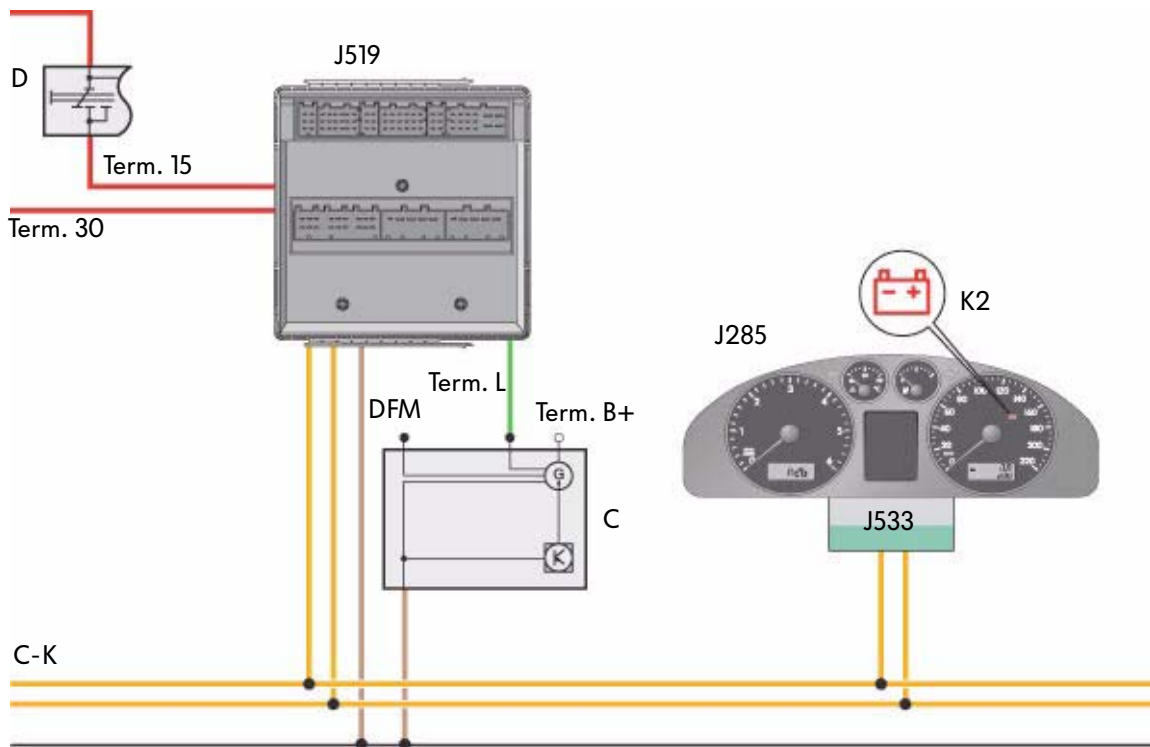

S311_014

Legend

- C 3-phase AC alternator
- D Ignition switch
- J285 Control unit with display in dash panel insert
- 519 Onboard power supply control unit

- J533 Data bus diagnostic interface in the dash panel insert
- K2 Alternator warning lamp
- C-K Convenience CAN data bus

Onboard power supply

Activation of the interior lighting, terminal 30G

Functional description

Terminal 30G is engaged via the onboard power supply control unit and supplies the interior lights with voltage. It is disabled with delayed effect after approx. 30 minutes (terminal 30G delayed) in order to avoid discharge of the onboard power supply battery since the interior lights are permanently switched on.

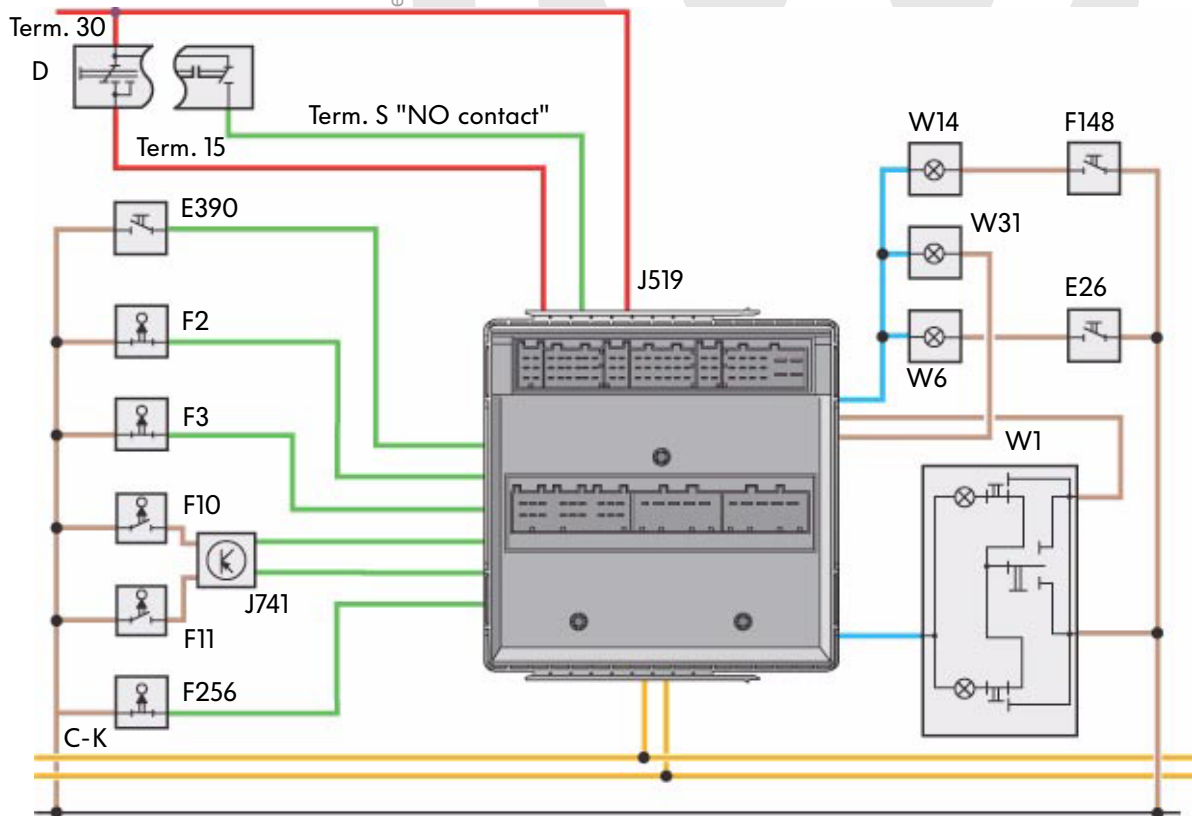

S311_015

Legend

| | | | |
|------|----------------------------------------------------|------|-------------------------------------------------|
| D | Ignition switch | F256 | Tailgate locking unit |
| E26 | Glove box light switch | J519 | Onboard power supply control unit |
| E390 | Interior light central switch button | J741 | Dual inverter relay |
| F2 | Door contact switch, driver side | W1 | Front interior light |
| F3 | Door contact switch, front passenger side | W6 | Glove box light |
| F10 | Rear left door contact switch | W14 | Illuminated vanity mirror, front passenger side |
| F11 | Rear right door contact switch | W31 | Front left entry light |
| F148 | Vanity mirror contact switch, front passenger side | C-K | Convenience CAN data bus |

Activation conditions

- Operation of an interior light switch
- Activation of terminal 15 (ignition "on")
- Operation of a door contact switch
- Operation of the bonnet contact switch

Immediate switch-off

The interior lights are switched off immediately

- if terminal 15 (ignition) is energised after opening and closing a door.
- if the vehicle is locked and no door is open.
- if the last door is closed and terminal 15 is energised.

Switch-off delay

The operating time of the interior lights is limited to 10 minutes if one or more doors are open and the ignition is off. If, in the case of several open doors, a door is closed, the interior lights will be switched on again for 10 minutes. If only one door was open, and is closed, the switch-off delay is 30 seconds.

The interior lights are switched on or off with a switch-off delay of approx. 30 seconds

- if the vehicle was unlocked with the ignition key or the remote control.
- if a door is opened and then closed again.
- if the ignition key is removed from the ignition/ starter switch.

Collision behaviour

In the event of a collision, the airbag control unit J234 sends a collision signal to the drive train CAN data bus. This signal is sent to the convenience CAN data bus via the data bus diagnostic interface J533 in the dash panel insert, and can be read by the onboard power supply control unit J519.

If a collision signal is detected, the onboard power supply control unit switches the interior lights on. They stay switched on until terminal 15 has been switched on and off again.

The "Interior lighting control" function is not active until terminal 15 has been energised.



Onboard power supply

The heated exterior mirror

Exterior mirror heating via door control unit, driver side J386

The mirrors on the driver and front passenger sides are heated when terminal L is active if the exterior mirror heating button E231 in the driver door is in the "Heat" setting. The door control unit, driver side J386 reads in the heating request and sends it via the convenience CAN data bus to the onboard power supply control unit J519. The door control unit, passenger side J387 reads in the heating request and sends it via the convenience CAN data bus to the onboard power supply control unit J519.

The onboard power supply control unit then switches the exterior mirror heating on. The signals are looped through the door control units.

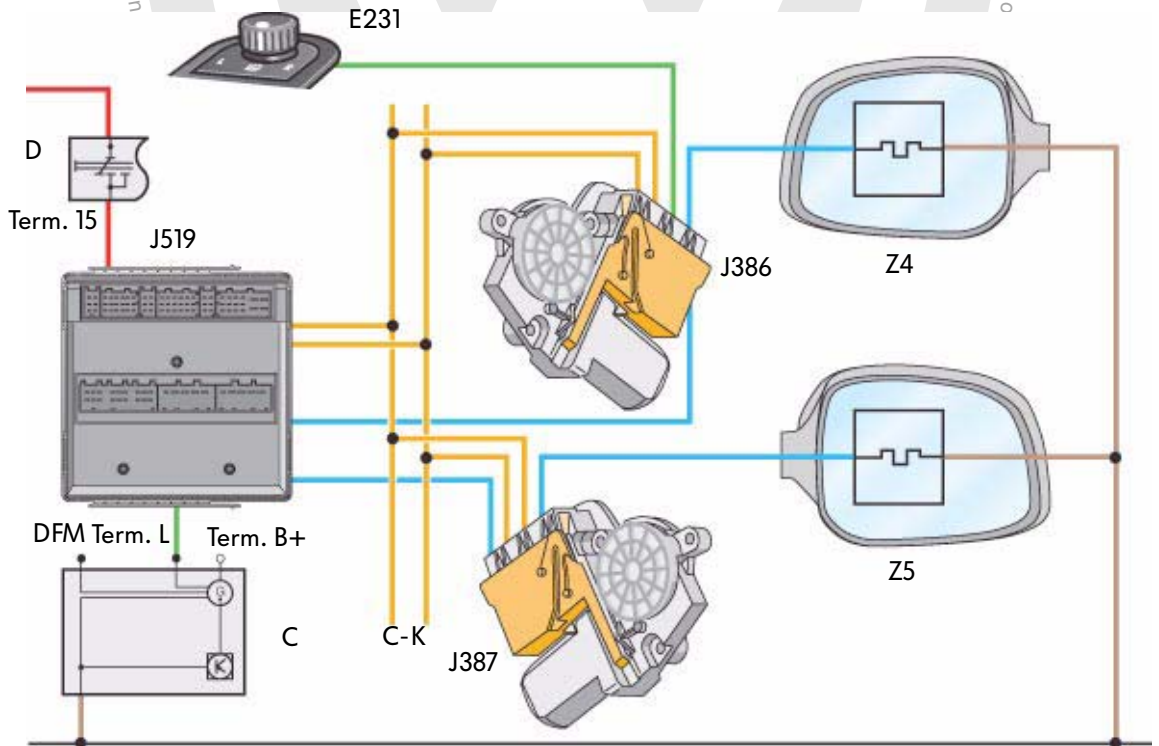

S311_017



Exterior mirror heater is only available in combination with electrically adjustable mirrors. It is not possible to adjust the mirror while it is being heated.

Exterior mirror heating without door control units

The mirrors on the driver and front passenger sides are heated when terminal L is active if the exterior mirror heating button E231 is pressed.

The onboard power supply control unit J519 receives the heating request directly from the switch and switches the exterior mirror heating on.

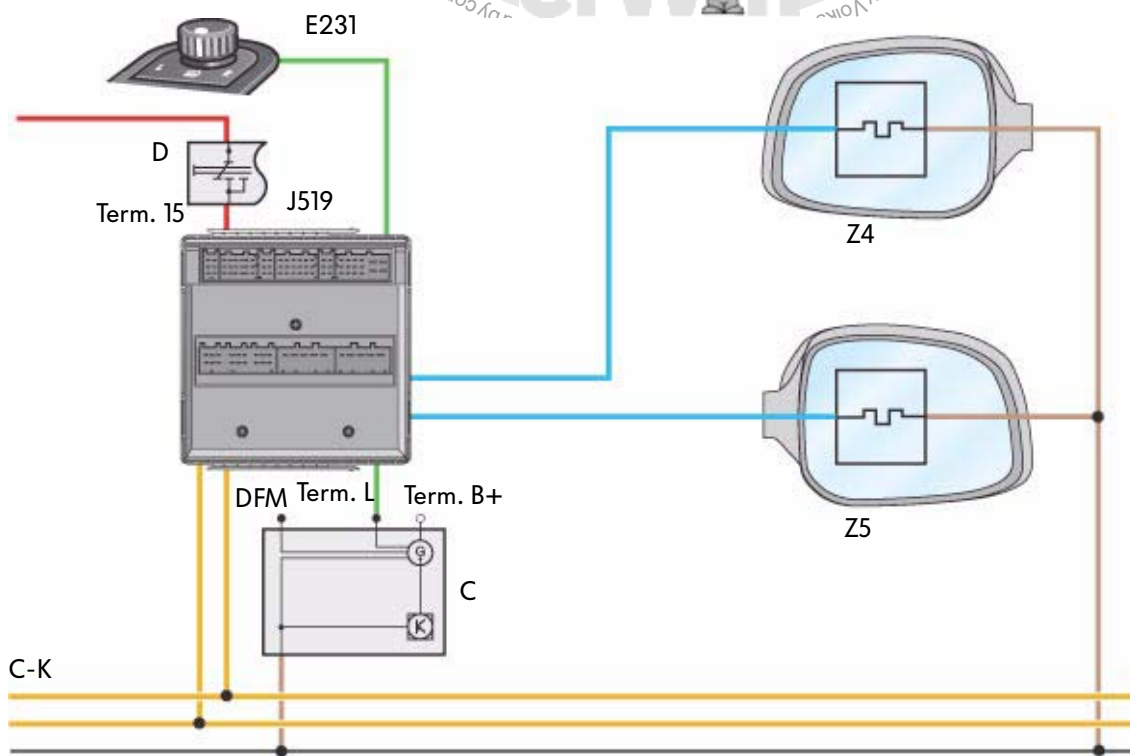

S311_018

Legend

- | | | | |
|------|-----------------------------------|------|----------------------------------------------|
| C | 3-phase AC alternator | J519 | Onboard power supply control unit |
| D | Ignition switch | Z4 | Heated exterior mirror, driver side |
| E231 | Exterior mirror heating button | Z5 | Heated exterior mirror, front passenger side |
| J386 | Door control unit, driver side | C-K | Convenience CAN data bus |
| J387 | Front passenger door control unit | | |

Onboard power supply

Function enable for sliding sunroof and window regulator

Functional description

The function enable for the sliding sunroof and the window regulator is issued by the onboard power supply control unit J519. The release is issued after turning on the ignition, and remains active after turning off the ignition until one of the front doors is opened, but for no longer than 10 minutes after terminal 15 active is switched off.

The function enable for the window regulator is issued via the convenience CAN data bus to the door control unit, driver side J386 and the door control unit, front passenger side J387.

The remote enable for the sliding sunroof is issued via a signal wire.

The door control units and the sliding sunroof adjustment control unit monitor the force which the electric motors have to apply in order to close window and the sliding sunroof. If a preset value is exceeded, the closing cycle is reversed.

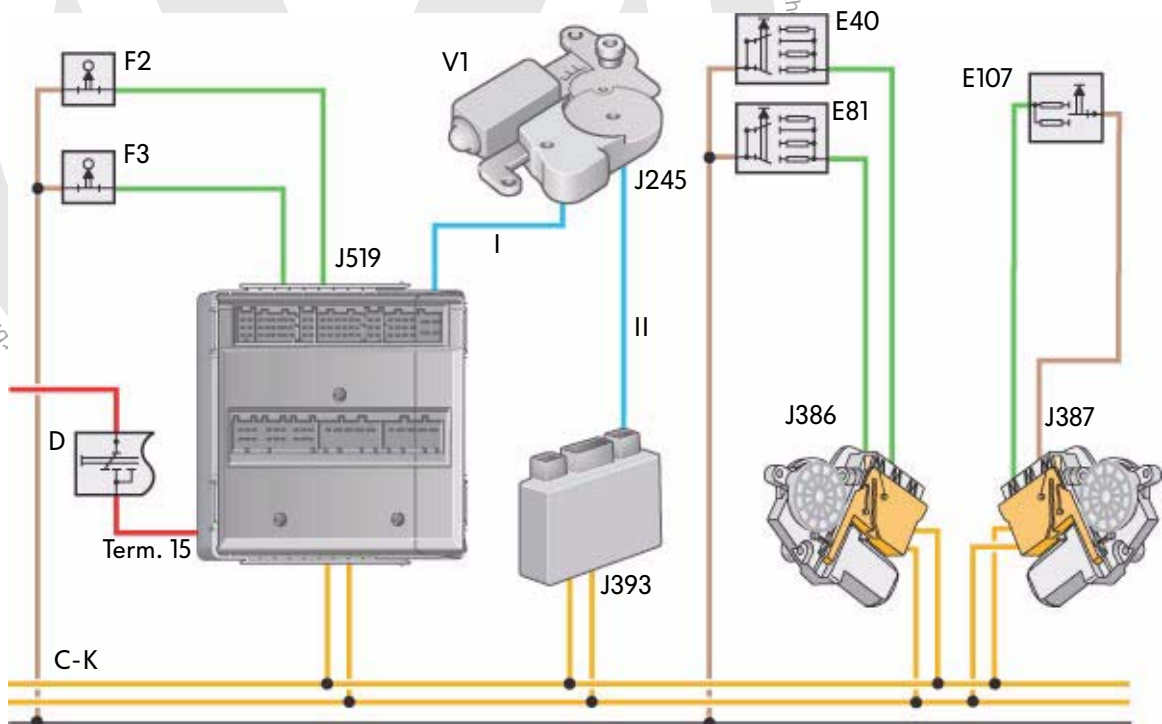

S311_019

Legend

| | | | |
|------|--------------------------------------------------|------|-----------------------------------------|
| D | Ignition switch | J387 | Front passenger door control unit |
| E40 | Front left window regulator switch | J393 | Convenience system central control unit |
| E81 | Front right window regulator switch, driver | J519 | Onboard power supply control unit |
| E107 | Window regulator switch, in front passenger door | V1 | Sliding sunroof motor |
| F2 | Door contact switch, driver side | I | Signal for function enable |
| F3 | Door contact switch, front passenger side | II | Signal for convenience operation |
| J245 | Sliding sunroof adjustment control unit | C-K | Convenience CAN data bus |
| J386 | Door control unit, driver side | | |

Activation of the battery isolation relay J7

Functional description

To supply the auxiliary heater with voltage, the Volkswagen Transporter is equipped with a second battery A1. The battery is charged by the vehicle's 3-phase AC alternator C.

The onboard power supply control unit activates the battery isolation relay. As a result, the second battery is, for charging purposes, connected to the onboard power supply or disconnected from the onboard power supply when the engine is switched off. Disconnecting the battery from the onboard power supply when the engine is switched off prevents, for instance, an operating additional water heater from discharging the vehicle battery A.

Activation conditions (relay closed)

- Terminal X on (ignition a)
- and
- alternator is charging

Deactivation conditions (relay open)

- Terminal X off (ignition "on")
- or
- alternator is not charging

The signal indicating whether the alternator is charging or not is detected by terminal L on the alternator via a separate cable.

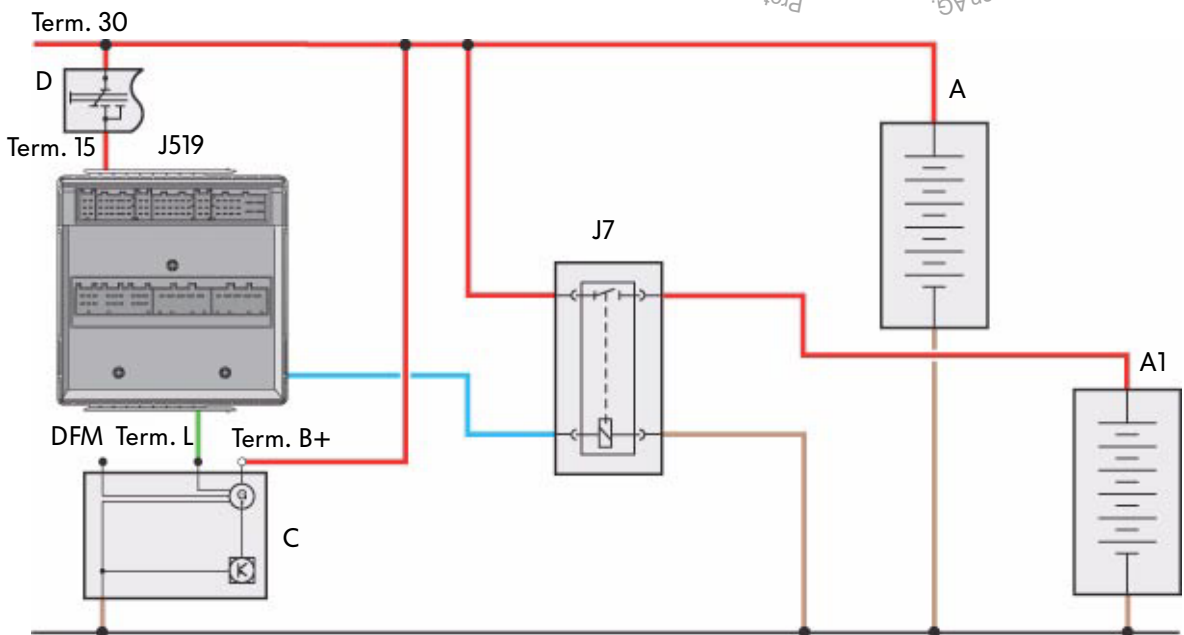

S311_020

Legend

| | | | |
|----|----------------|------|-----------------------------------|
| A | Battery | D | Ignition switch |
| A1 | Second battery | J7 | Battery isolation relay |
| C | Alternator | J519 | Onboard power supply control unit |

Onboard power supply

Control of the starter inhibitor

Functional description

The onboard power supply control unit J529 activates the starter inhibitor relay J207.

The following input signals are required:

- Terminal 15 on (ignition a)
- Terminal 50 on (ignition switch start)
- Enable signal from anti-theft alarm system
- Enable signal from automatic gearbox control unit J217

The enable signal from the anti-theft alarm system is sent by the convenience system central control unit J393 via the convenience CAN data bus.

If unauthorised entry is gained to the vehicle and the anti-theft alarm system is triggered, a corresponding signal is sent to the convenience CAN data bus and read by the onboard power supply control unit. In this case, starter inhibitor relay J207 will not be activated and the engine cannot be started.

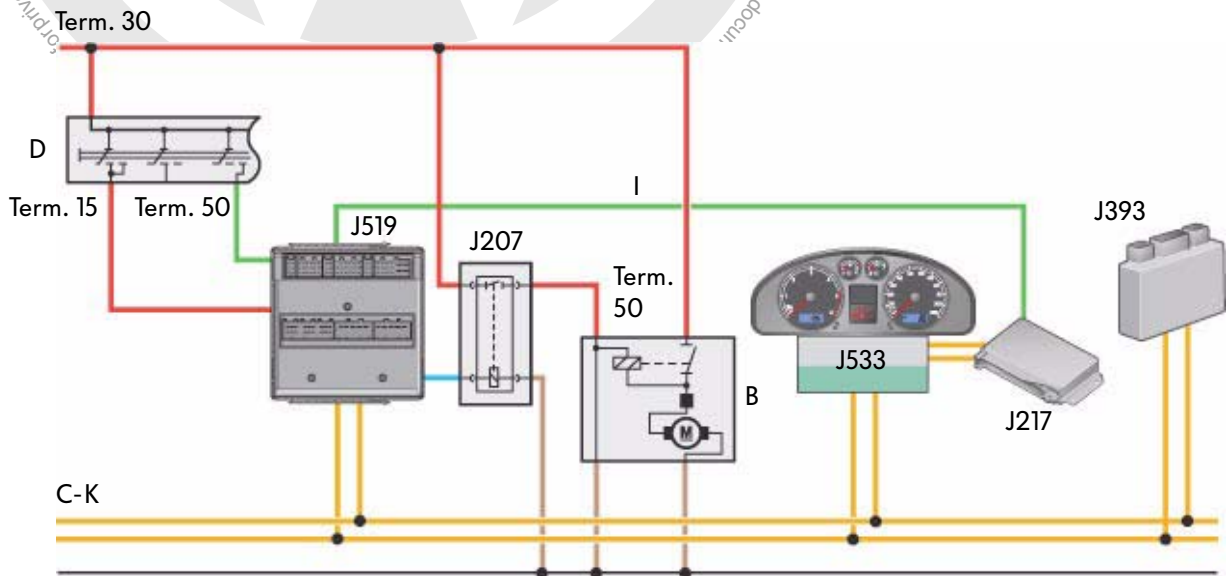

S311_021

Legend

| | | | |
|------|-----------------------------------------|------|-------------------------------------------------|
| B | Starter | J519 | Onboard power supply control unit |
| D | Ignition switch | J533 | Data bus diagnosis interface |
| J207 | Starter inhibitor relay | C-K | convenience CAN data bus |
| J217 | Automatic gearbox control unit | I | Enable signal via conventional cable connection |
| J393 | Convenience system central control unit | | |

Activation of the reversing lights

Variants

There are two function variants:

Vehicles with manual gearbox

On vehicles with a manual gearbox, the reversing lights are activated directly by the reversing light switch F4.

The onboard power supply control unit reads this signal and sends it to the convenience CAN data bus. The drive train CAN data bus receives the signal via the data bus diagnostic interface J533.

Vehicles with automatic gearbox

On vehicles with an automatic gearbox, the reverse gear is detected via the selector lever, read by the automatic gearbox control unit J217 and sent to the drive train CAN data bus.

The signal is sent to the convenience CAN data bus via the data bus diagnostic interface in the dash panel insert and read by the onboard power supply control unit which in turn energises the reversing lights.

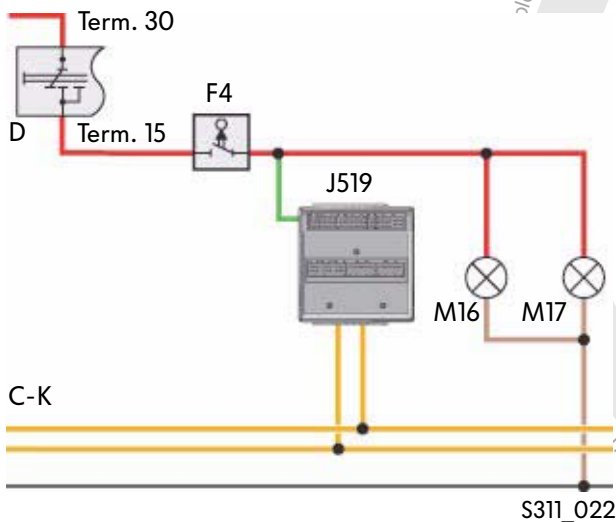

Legend

- D Ignition switch
- F4 Reversing light switch
- J217 Automatic gearbox control unit
- J519 Onboard power supply control unit

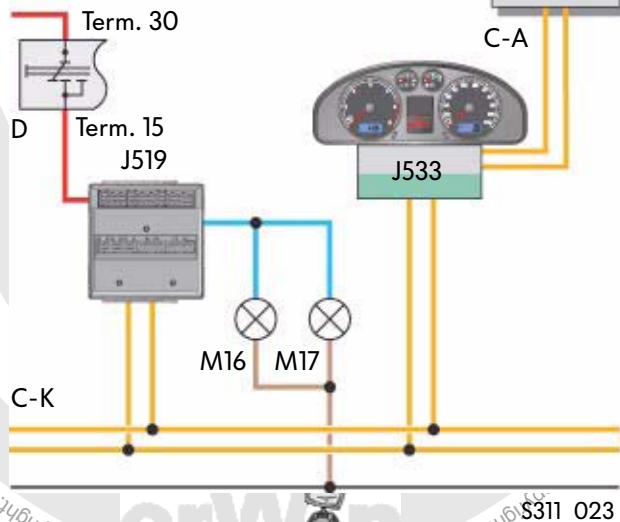

- J533 Data bus diagnosis interface
- M16 Reversing light bulb, left
- M17 Reversing light bulb, right
- C-K Convenience CAN data bus
- C-A Drive train CAN data bus

Onboard power supply

Switches and instruments light regulation

Functional description

The switch and instrument light regulator E20 generates a pulse-width modulated signal which is sent via the onboard power supply control unit to the convenience CAN data bus as a digital message. The control units connected to the convenience CAN data bus receive this message and control the illumination of the switches and display instruments as signalled.

The hazard warning light switch light is activated directly by the onboard power supply control unit.

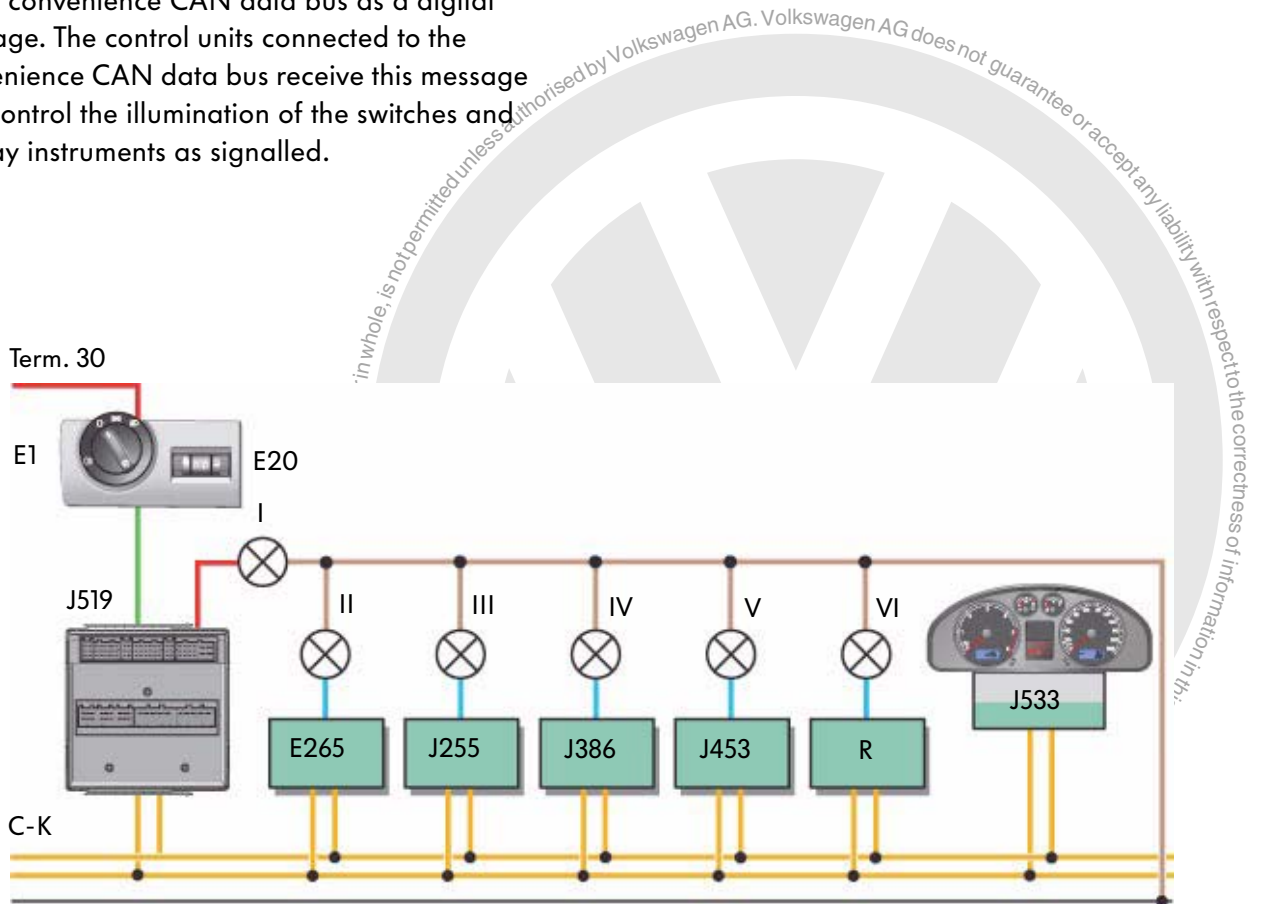

The control units shown in the diagram are only intended as examples.

S311_016

Legend

| | | | |
|------|---------------------------------------------|-----|---------------------------------------------------|
| E1 | Light switch | I | Hazard warning light switch lamp |
| E20 | Switch and instrument light regulator | II | Rear Climatronic operating and display unit lamp |
| E265 | Rear Climatronic operating and display unit | III | Climatronic operating and display unit lamp |
| J255 | Climatronic control unit | IV | Driver door operating unit lamp |
| J386 | Door control unit, driver side | V | Multi-function steering wheel control button lamp |
| J453 | Multi-function steering wheel control unit | VI | Radio lamp |
| J519 | Onboard power supply control unit | C-K | Convenience CAN data bus |
| J533 | Data bus diagnosis interface | | |
| R | Radio | | |

Control of electrical fuel pump feed

Functional description

If the driver's door is opened and terminal 15 is switched off, the onboard power supply control unit activates the electrical fuel pump for approx. 0.1 second.

If the door stays open, the fuel pump is reactivated after approx. 1 minute for approx. 0.1 seconds. The fuel pump is activated for a final time after a further minute. If the ignition is switched on during the feed cycle, the feed cycle will stop immediately.

If the ignition is switched off and the engine has not been started, the onboard power supply control unit inhibits feed for 1 minute.

After the engine is started, the fuel pump is activated by the engine control unit.

If a collision is detected, electrical fuel pump feed will be deactivated.

To reactivate the feed function, the ignition must be switched off and on again three times.

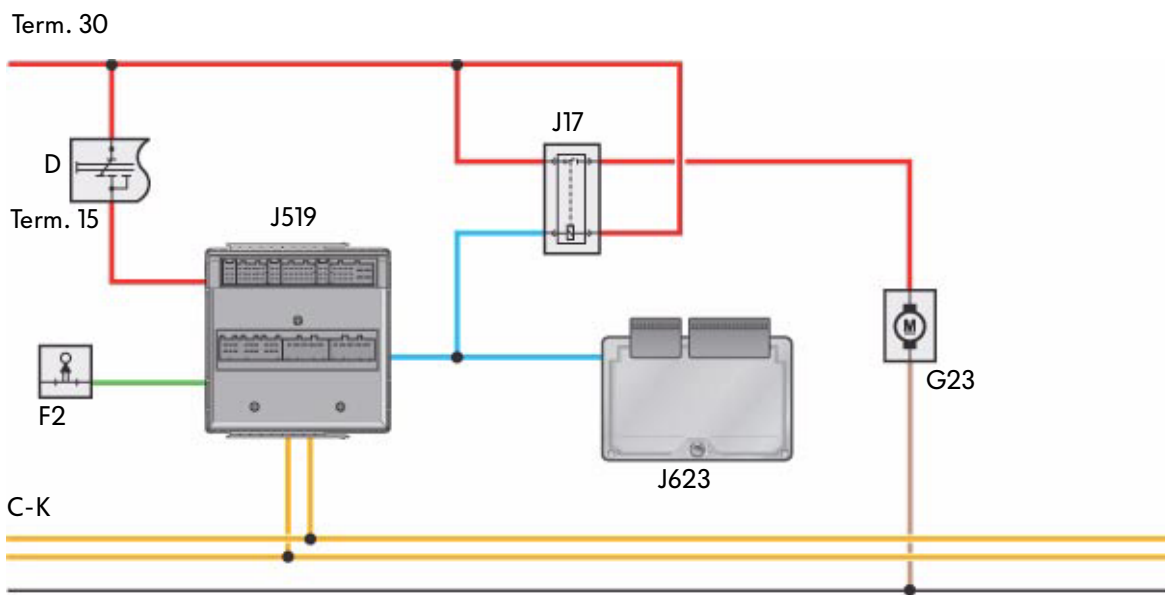

S311_024

Legend

| | | | |
|-----|----------------------------------|------|-----------------------------------|
| D | Ignition switch | J519 | Onboard power supply control unit |
| F2 | Door contact switch, driver side | J623 | Engine control unit |
| G23 | Fuel pump | C-K | Convenience CAN data bus |
| J17 | Fuel pump relay | | |

Onboard power supply

Electrical load management

General description

The electrical load management ensures that there is always enough energy in the battery to turn the engine over.

For this purpose, the electrical consumers of the convenience system are deactivated. The standard of technical safety is retained.

To switch off the consumers, the onboard power supply control unit evaluates the engine speed, the battery voltage and the alternator load via the DF signal (dynamo field).

From this information and from information about which consumers are switched on with short activation periods, the onboard power supply control unit carries out an evaluation of the onboard power supply load state.

Based on this evaluation, the onboard power supply control unit can increase engine speed via the engine control unit. The deactivation of convenience consumers is still possible in the same way.

Measures

In the following cases the load management system initiates measures to maintain the onboard power supply.

- Extremely short trips
- Starting the engine
- Critical onboard power supply status
- Avoidance of voltage drops caused by high current consumers related to vehicle safety
- Collision

High current consumers include:

- Hydraulic pump for ABS/ESP
- Solenoid valves for ABS/ESP
- Twin washer pump
- Window regulator motor
- Sliding door motor

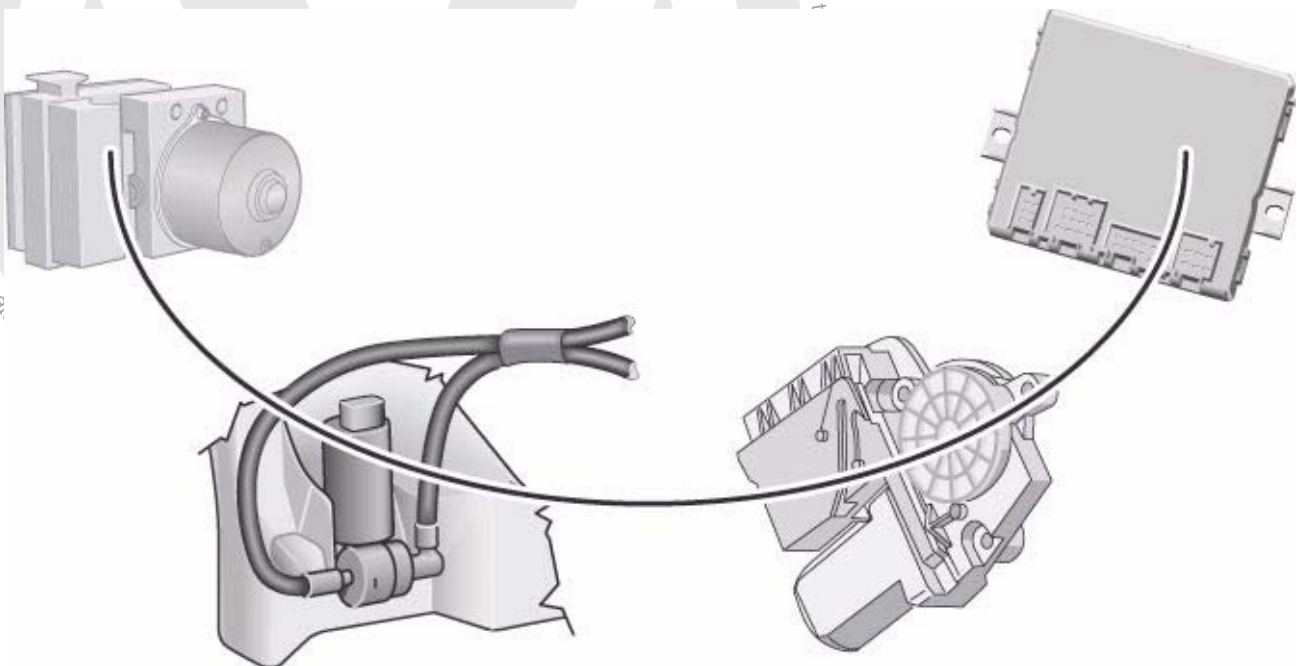

S311_129

Measures in response to extremely short trips

Due to the frequency of critical onboard power supply states, the onboard power supply control unit is able to identify extremely short trips. In this case, consumers are allowed to be disabled during the start phase in order to retain the battery charge.

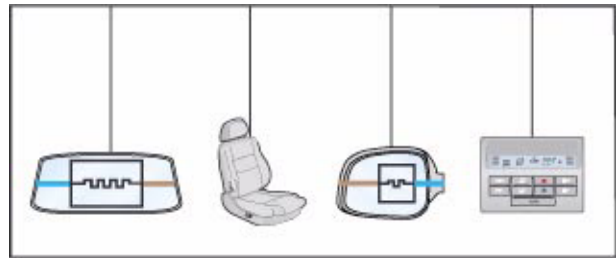

Switchable consumers

S311_130

Measures in response to engine starting

To distribute peak surge currents over time for the following current consuming convenience systems, they are enabled at intervals of 2 seconds after starting the engine.

- Climatronic
- Heated exterior mirrors
- Seat heating
- Heated rear window

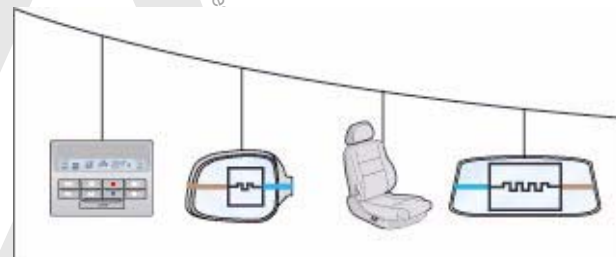

Enabling sequence

S311_124



Onboard power supply

Measures in response to critical onboard power supply status

Measure I

The onboard power supply status is determined via the battery voltage.

If the battery voltage is less than 12.7 V, the onboard power supply control unit requests the engine control unit to increase the engine idle speed.

This request can be issued directly after starting the engine.

Measure II

If the battery voltage is less than 11.0 V during the start phase (up to approx. 4 minutes after Term. 50 on) and the alternator is active, or less than 12.2 V during operation, the following current consuming convenience systems are not enabled or switched off in a defined order. Due to the time period of four minutes, all selected function are, where possible, made available to the driver.

- Heated rear window
 - Seat heating
 - Heated exterior mirrors
 - Climatronic
 - Air conditioning system
 - PTC heater is currently not fitted
- An inactive current consuming convenience system is skipped.

Switch-off sequence

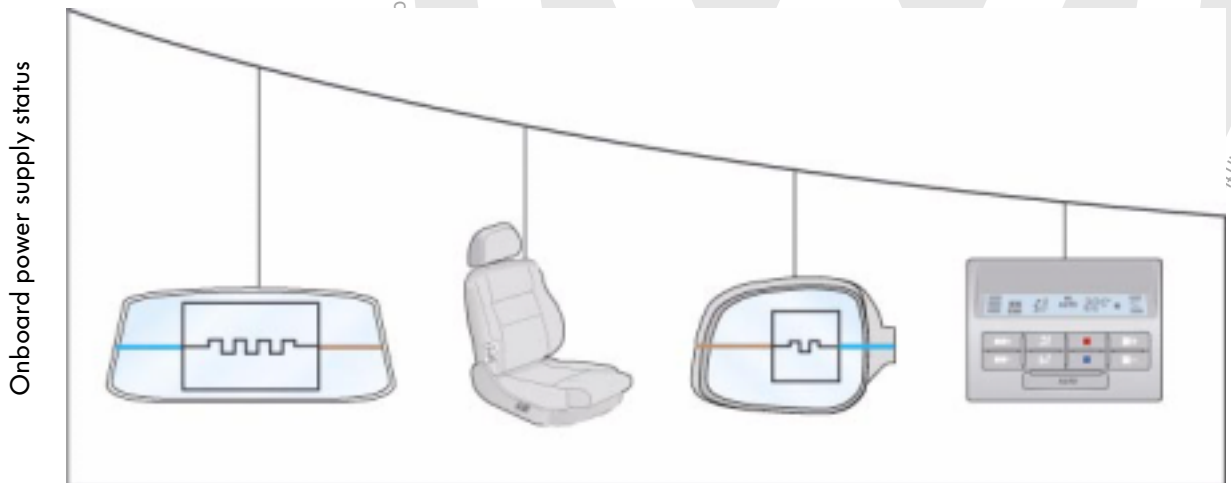

Consumer deactivation

S311_125

Measure III

If the battery voltage is less than 11.5 V and the alternator is inactive, the following consumers will be switched off.

- | | | |
|-----------------------------|-------|---------|
| ● Interior lights | W I | Stage 1 |
| ● Reading lights | W II | Stage 1 |
| ● Glove box light | W III | Stage 1 |
| ● Luggage compartment light | W IV | Stage 1 |
| ● Seat heating | Z I | Stage 1 |

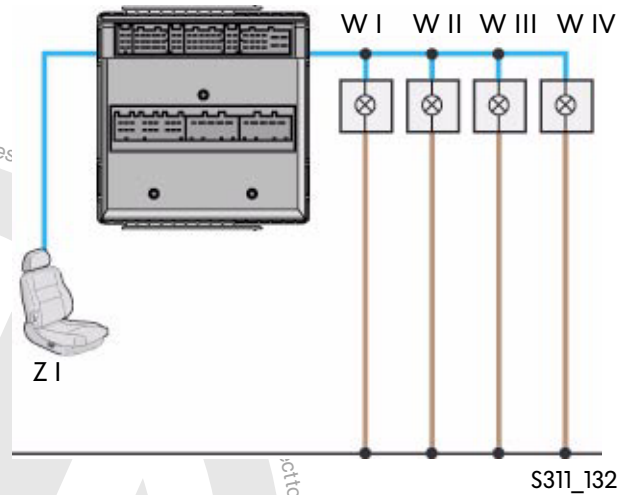

Measures to avoid significant voltage drops

To prevent significant voltage drops on activation of a high current consumer relevant to vehicle safety (e.g. hydraulic pump for ABS/ESP), the current consuming convenience systems with the lowest priority is disabled.

- | | |
|----------------------|------------------|
| ● Heated rear window | Priority level 1 |
| ● Seat heating | Priority level 2 |

Measures in response to a collision

In the event of an accident with a defined minimum force, the following consumers are disabled.

- Heated rear window
- Seat heating
- Heated exterior mirrors
- Climatronic
- Air conditioning system

If the high current consumer is no longer in operation, the current consuming convenience systems is re-enabled.

Cancellation of disables

Disables are cancelled if the deactivation condition no longer exists.

Onboard power supply

Control unit with display unit in dash panel J285

Variants

The following type variants are used.

- Lowline variant
- Midline variant
- Highline variant

All variants are equipped with:

Analog displays with pointer instruments

- Rev counter G5
- Speedometer G21
- Coolant temperature gauge G3
- Fuel gauge G1

Digital displays

- Digital clock Y2
- Two-line odometer display Y4

Central display

- The Lowline variant has a selector lever position indicator for the automatic gearbox
- The Midline variant has a Mini-DOT matrix display.
- The Highline variant has a DOT matrix display plus, in the Multivan, an oil temperature display Y12 and a vehicle voltage display Y11.

Warning lamps

- Left turn signal warning lamp K65
- Right turn signal warning lamp K94
- Warning lamps in the central display
- Warning lamps in the rev counter
- Warning lamps in the speedometer

Lowline variant



S311_038

Midline variant



S311_039

Highline variant



S311_114

Display features

The additional instruments have a damping function in order to prevent frequent variation of the display. The pointers maintain a constant position in the normal operating ranges. If the operating conditions change and it is necessary to inform the driver, the pointer position will change.

Coolant temperature gauge

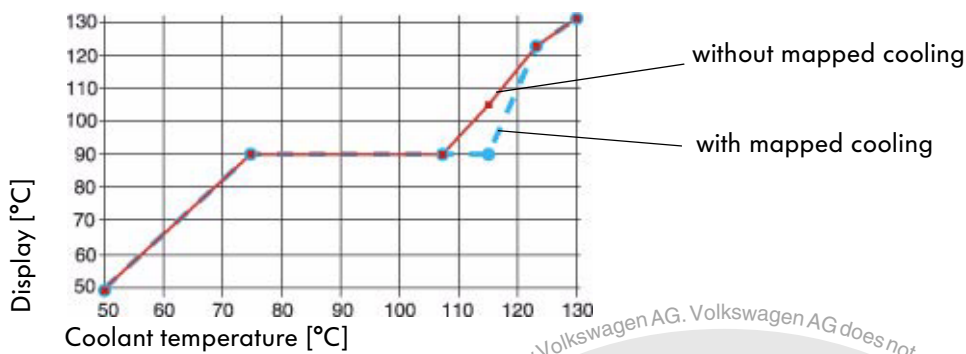

Oil temperature display

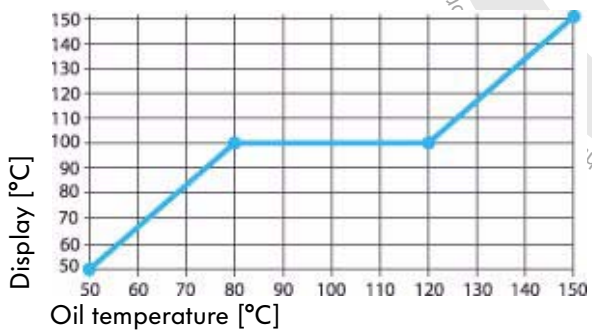

S311_110

Onboard power supply voltage display

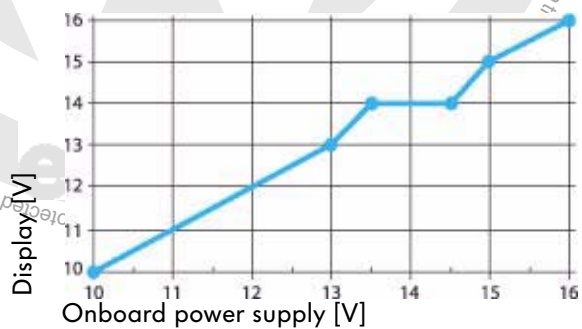

S311_111

Onboard power supply

Warning lamp function test

The warning lamps, which come on for approx. 3 seconds after turning on the ignition (Term. 15 on) and then go off again, are checked by the control unit which has a display in the dash panel insert. This includes the alternator warning lamp K2.

The other warning lamps (e.g. the airbag warning lamp K75) are activated by their associated control unit. They stay on until the internal test of the control unit has been completed and no malfunction is detected.

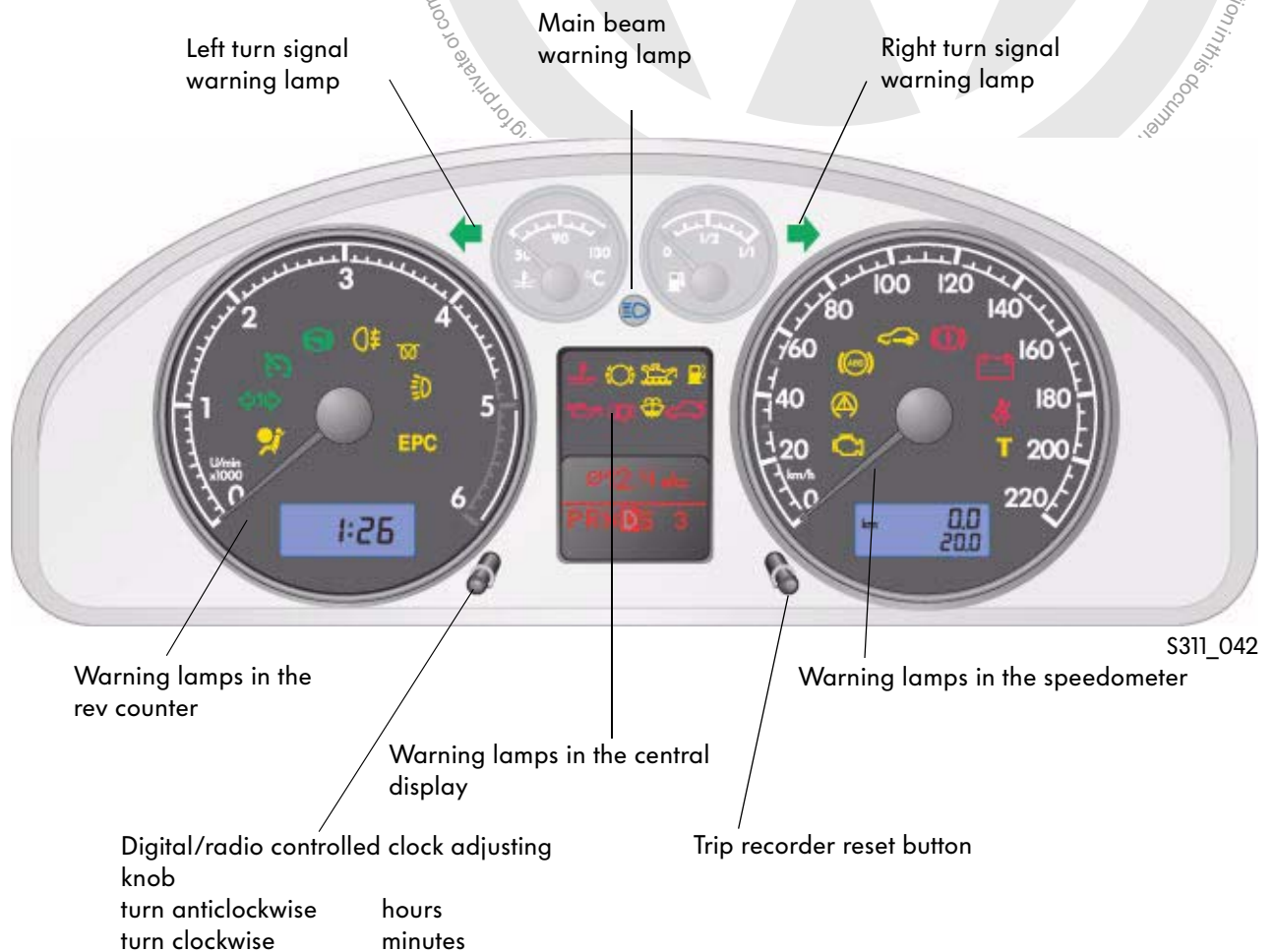

Electrical tachograph

Tachograph G24

The tachograph G24 is a control unit in DIN radio format. The display shows the date, time, mileage, the adjusted workgroups and the symbols for the selected speed-time charts.

If a fault in the system occurs, it will be indicated via the warning lamp "T".

Time display

The time is displayed digitally in hours and minutes. The time source is dependent on the vehicle specification. If there are several sources in the vehicle, the time information is prioritised as follows:

- Highest priority tachograph
- Second highest priority radio controlled clock
- Third highest priority quartz clock

System overview

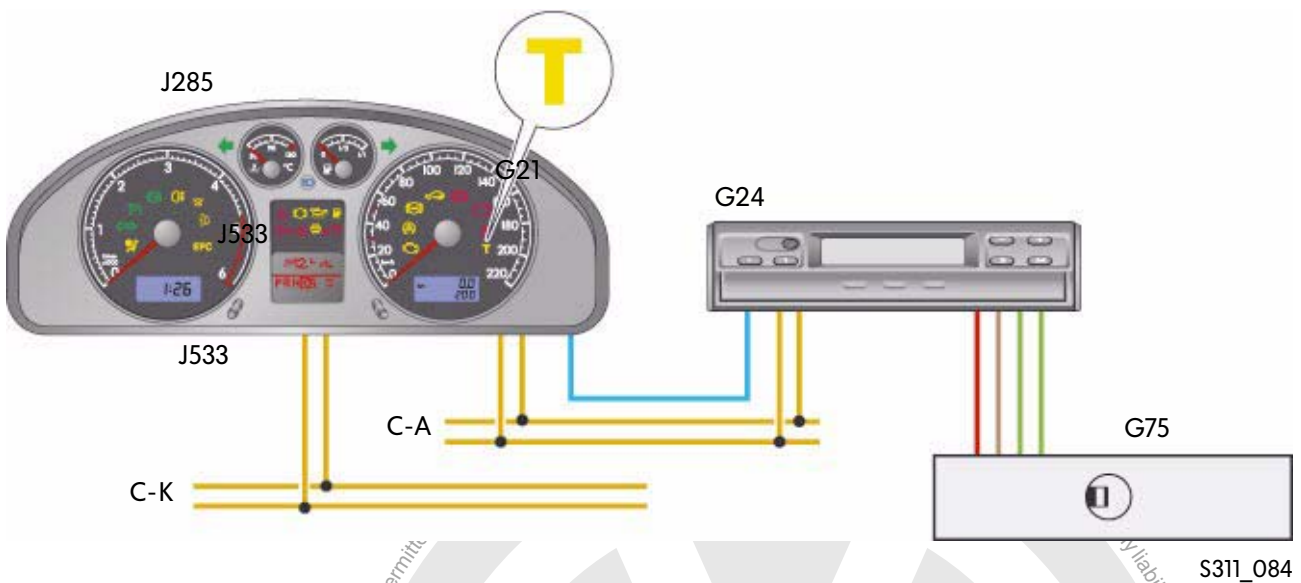

Legend

- G24 Tachograph
- G75 Tachograph sender
- J285 Control unit with display in dash panel insert
- J533 Data bus diagnostic interface in dash panel insert
- C-K Convenience CAN data bus
- C-A Drive train CAN data bus



Work on the tachograph system may only be performed by trained personnel. Persons who make unauthorised modifications to tachographs, signal wires and display units in order to influence the recording process will be liable to prosecution under criminal law.

Convenience and safety electronics

The convenience system central control unit J393

Fitting location

The convenience system central control unit is located on the subframe of the front passenger seat on the left. It controls and monitors the functions of the central locking and the anti-theft alarm systems.

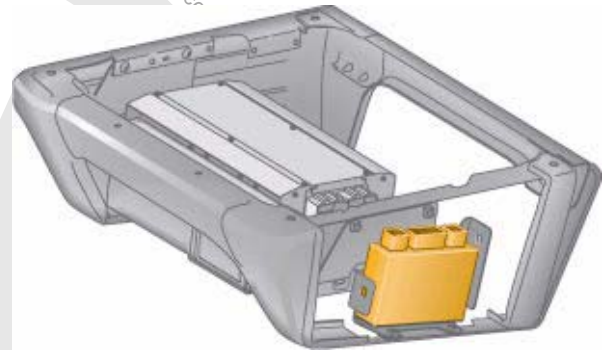

S311_043

Functional description

All central locking motors are activated directly by the convenience system central control unit. Depending on equipment specification, up to five motors are possible.

Operating points

The central locking system can be operated at the following points:

- The contact switch in lock cylinder, driver side F241
- The contact switch in lock cylinder, front passenger side F242 (not available with radio wave remote control)
- radio wave remote control
- Interior locking switch, driver side E150
- Interior locking switch, front passenger side E198 (North American region only)

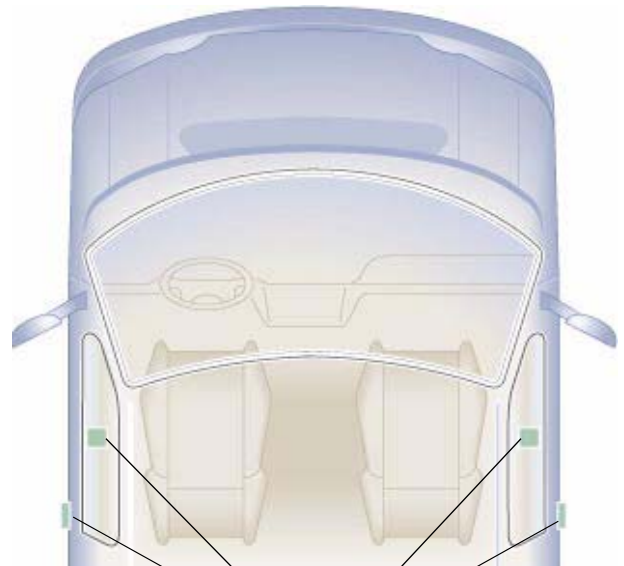

S311_119

Operating points

Door locks

The door locks can assume three states:

- Unlocked Door can be opened from the exterior and interior.
- Locked Door can only be opened from the interior.
- Safe Door cannot be opened from the exterior or interior.

The "Safe" function is not implemented on door locks in vehicles in the North American region. "CLS without Safe" is encoded in the convenience system central control unit.

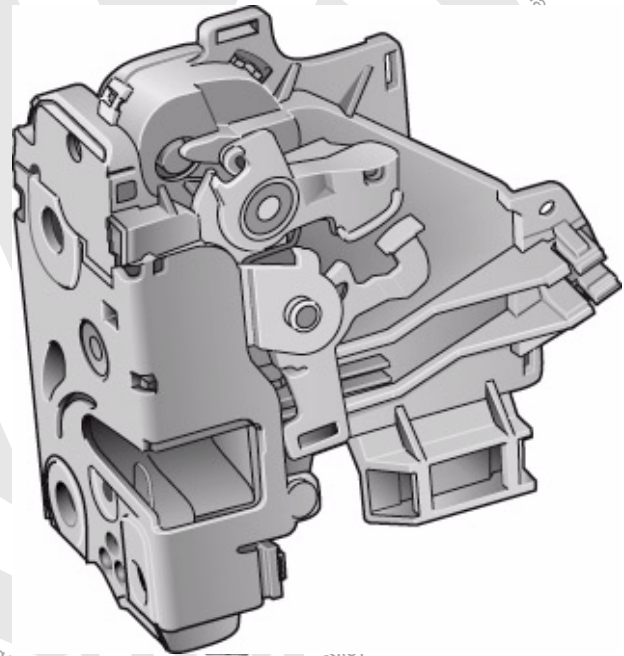

S311_057

Vehicle state

The central locking warning lamp K133 in the driver door indicates the locked state of the vehicle.

In the case of convenience system central control units anti-theft alarm system, the warning lamp flashes when the alarm system is activated and primed.

In the case of convenience system central control units with or without deactivated anti-theft alarm system, warning lamp flashes when all door locks are safe.

If the central locking is encoded "without safe", the warning lamp flashes immediately after locking.



S311_120

Convenience and safety electronics

Function chart

Legend

- D Ignition switch
- E150 Interior locking switch, driver side
- E198 Interior locking switch, front passenger side
- F2 Door contact switch, driver side
- F3 Door contact switch, front passenger side
- F10 Rear left door contact switch
- F11 Rear right door contact switch
- F256 Tailgate locking unit
- F131 Central locking actuator, front left
- F132 Central locking actuator, rear left
- F133 Central locking actuator, front right
- F134 Central locking actuator, rear right
- F241 Contact switch in lock cylinder, driver side
- F242 Contact switch in lock cylinder, front passenger side
- F243 Central locking actuator (Safe), driver door
- F245 Central locking actuator (Safe), rear left door
- F246 Central locking actuator (Safe), rear right door
- F256 Tailgate locking unit
- J386 Door control unit, driver side
- J387 Front passenger door control unit
- J393 Convenience system central control unit
- J519 Onboard power supply control unit
- J741 Dual inverter relay
- K133 Central locking warning lamp -Safe-
- M5 Turn signal bulb, front left
- M6 Turn signal bulb, rear left
- M7 Turn signal bulb, front right
- M8 Turn signal bulb, rear right
- R47 Central locking and anti-theft alarm system aerial
- V53 Central locking motor, tailgate
- V56 Central locking motor, driver door
- V57 Central locking motor, front passenger door
- V97 Central locking motor, rear right door
- V115 Central locking motor, rear left door
- C-K Convenience CAN data bus

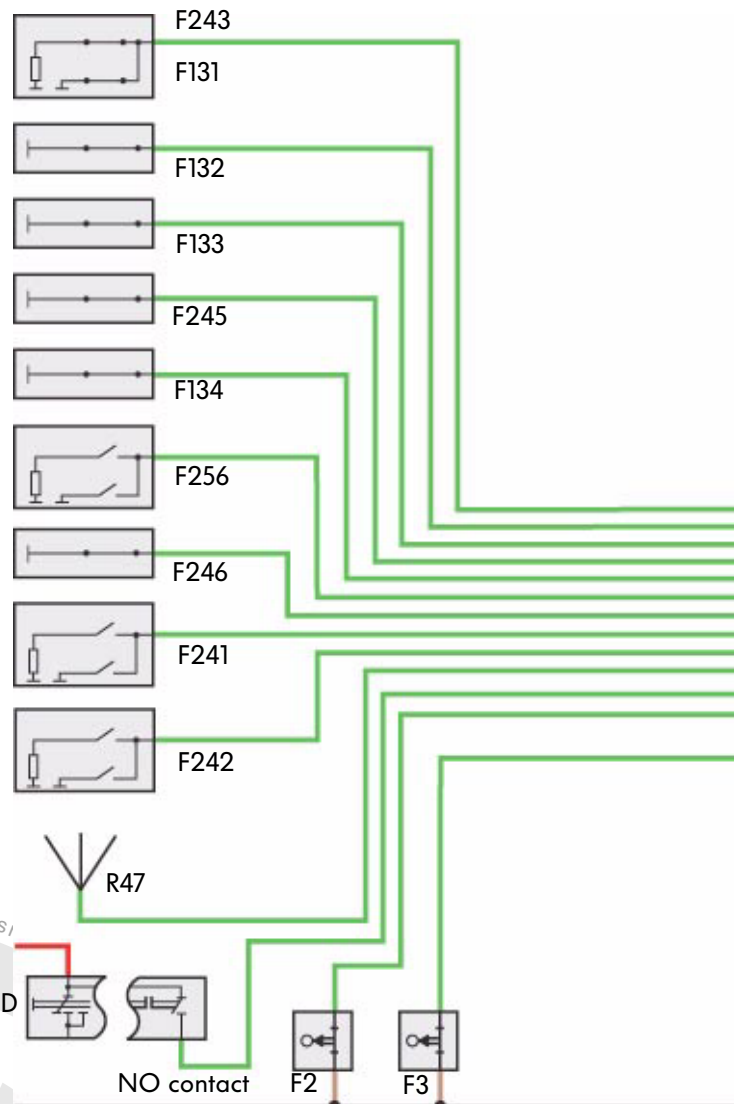

S311_044

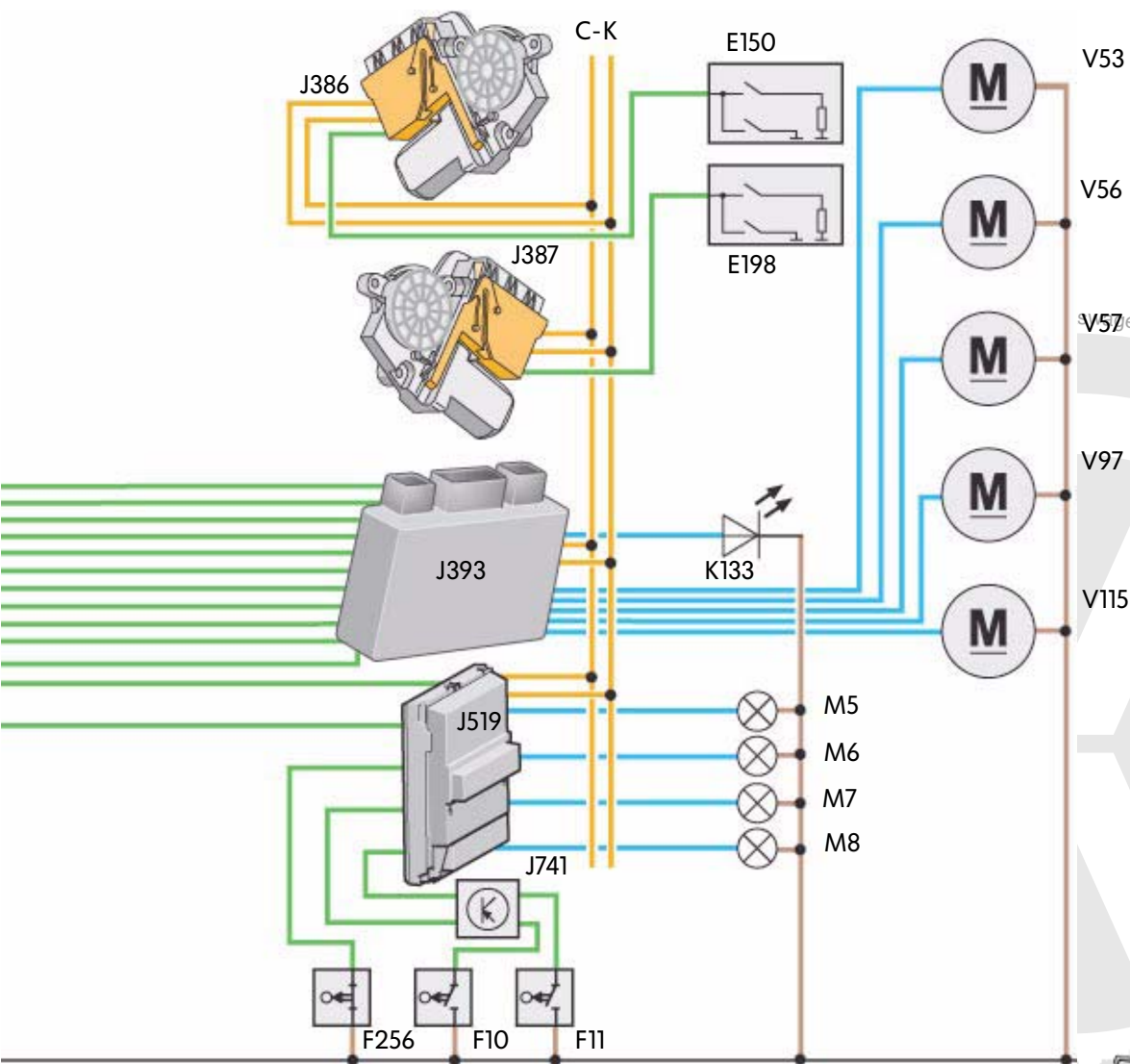

Protected by copyright. Copyright by Volkswagen AG. Volkswagen AG does not guarantee or accept any liability with respect to the correctness of information in this document.



Sliding door post-locking

If a sliding door is open, it will not be locked. After the door has been closed, a comparison is made to determine whether the required status of the sliding door matches the actual status of the other vehicle doors. If there is no match, the sliding door will be post-locked.

Convenience and safety electronics

Operation of the central locking system via the contact switches in the lock cylinder

The contact switches transmit the open or close signal to the convenience system central control unit, which controls the central locking motors. The central locking system can be encoded for individual door opening or all-door opening in the convenience system central control unit. If individual door opening is configured, this setting is acknowledged via the flashing lights only when the doors are opened for the first time.

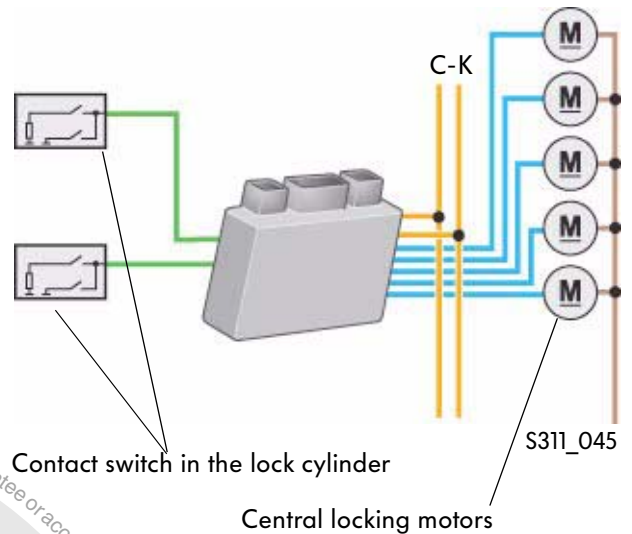

Relocking after open with the radio wave remote control

After the vehicle has been opened with the radio wave remote control, the vehicle is automatically relocked after approx. 30 seconds.

Relocking can be prevented by the following conditions:

- Opening a door
- Open driver door
- Turning on the ignition
- Change of door status



Unlocking after removal of key from ignition lock

If the key is removed from the ignition/starter switch (NO contact opened), the onboard power supply control unit sends this information to the convenience CAN data bus.

The convenience system central control unit then issues an unlock command to the central locking motors.



Overload protection

To protect the central locking motors against thermal overload, continued operation of the motors is inhibited for approx. 30 seconds after approx. 50 operations (lock and/or safe).

Unlocking cycles are performed provided that the states of the door locks are not identical, e.g. locked and unlocked.



S311_046

Collision response

In the event of a collision, the airbag control unit sends a collision message to the CAN data bus. The convenience system central control unit receives this message via the data bus diagnostic interface and unlocks all locked doors if the ignition is on. The doors cannot be locked again via the interior locking switch until the ignition has been switched off and on again. Locking via the contact switches in the door locks is disabled. To cancel the disable, the ignition first has to be switched on. After that, a door must be opened if the key is not in the ignition lock (NO contact off) or after switching the ignition on again.

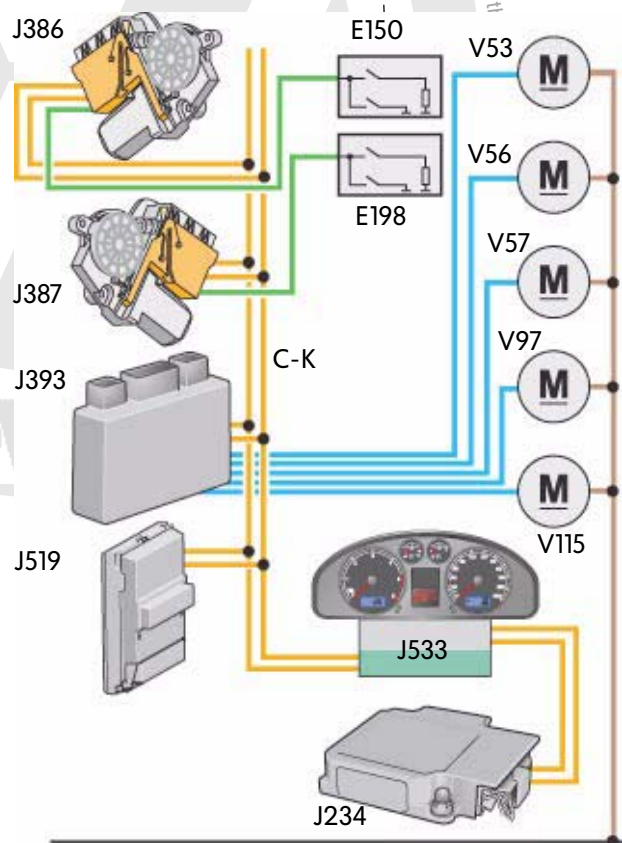

S311_047

Legend

- E150 Interior locking switch, driver side
- E198 Interior locking switch, front passenger side
- J234 Airbag control unit
- J386 Door control unit, driver side
- J387 Front passenger door control unit
- J393 Convenience system central control unit
- J519 Onboard power supply control unit

- J533 Data bus diagnosis interface
- V53 Central locking motor, tailgate
- V56 Central locking motor, driver door
- V57 Central locking motor, front passenger door
- V97 Central locking motor, rear right door
- V115 Central locking motor, rear left door
- C-K Convenience CAN data bus

Convenience and safety electronics

Anti-theft alarm system

Monitored areas

The anti-theft alarm system monitors all four doors, the tailgate, the bonnet and the terminal 15 signal.

Activation

The anti-theft alarm system is primed when the vehicle is locked. The anti-theft alarm is not primed if the ignition is on or if the driver door is open. The primed anti-theft alarm system is indicated by the central locking warning lamp K133. The display is limited to a max. period of 14 days, provided that the CAN data bus goes into the idle state.

Deactivation

The anti-theft alarm system is deactivated via the radio wave remote control. When the vehicle is opened via a door lock, the ignition must, at the latest, be switched on after 15 seconds. Otherwise the alarm will be triggered.

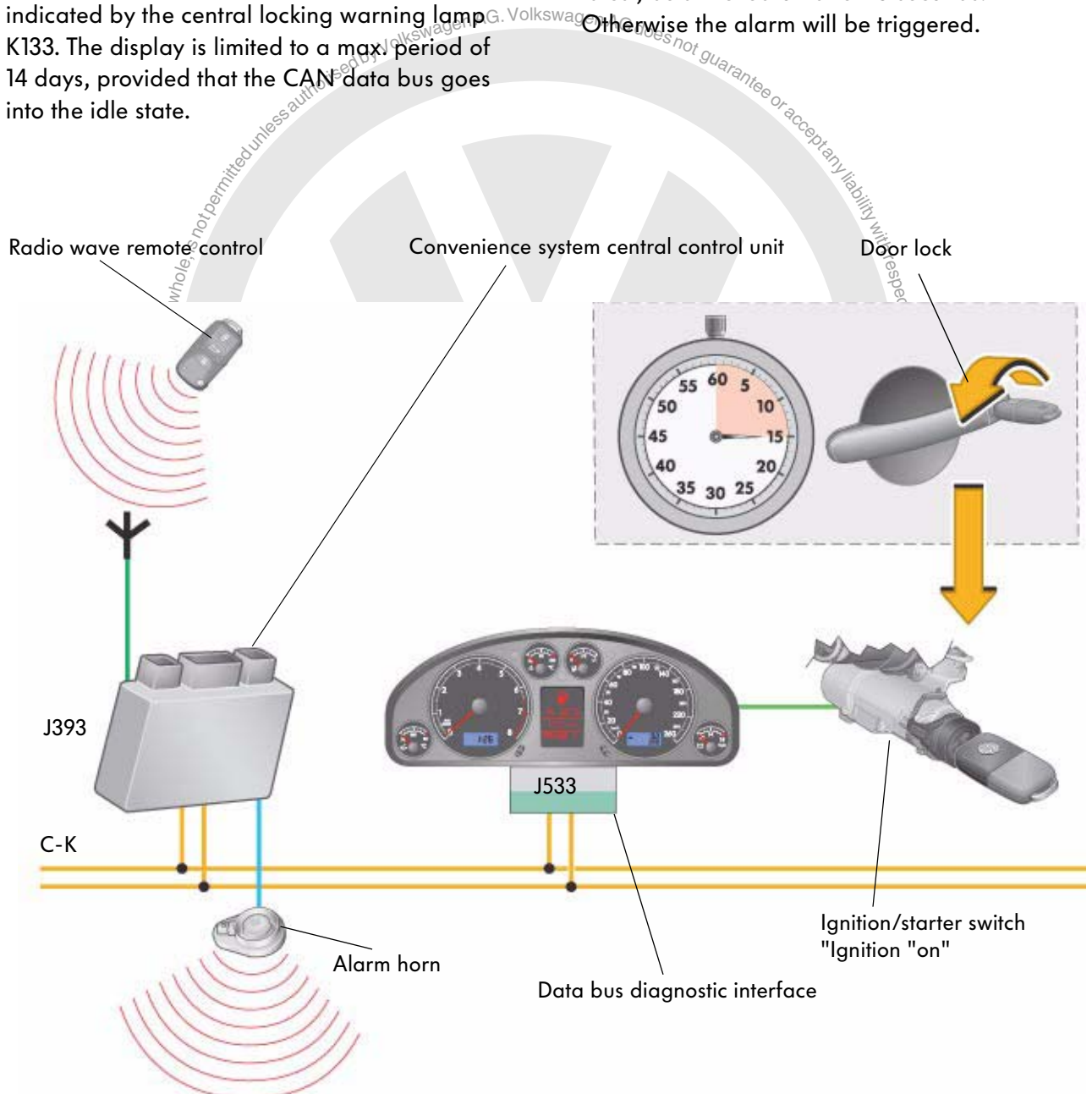

S311_048

Triggering the anti-theft alarm system

If an anti-theft alarm system is primed, a change in the monitored areas will cause the alarm to trigger.

If the alarm is triggered again while the alarm horn is sounding, the alarm time will not be affected. If the alarm is triggered again at the end of the first alarm, the alarm horn will sound again.

If an alarm is triggered by "terminal 15 on", with the vehicle in the SAFE state, the vehicle will be locked and the central locking warning lamp will no longer be activated.

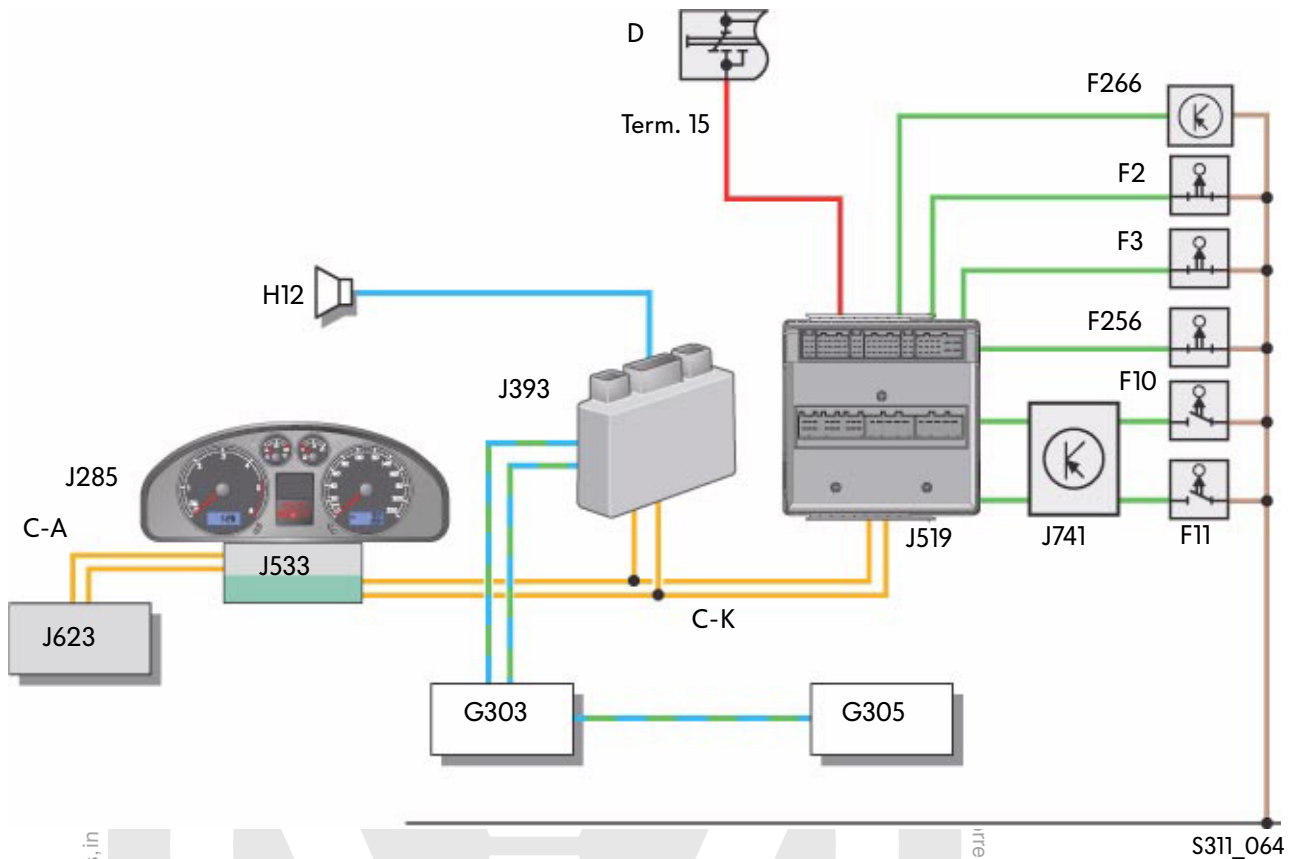

Legend

- | | | | |
|------|-------------------------------------------|------|--------------------------------------------------------------|
| D | Ignition switch | H12 | Alarm horn |
| F2 | Door contact switch, driver side | J285 | Control unit with display in dash panel insert (immobiliser) |
| F3 | Door contact switch, front passenger side | J393 | Convenience system central control unit |
| F10 | Rear left door contact switch | J519 | Onboard power supply control unit |
| F11 | Rear right door contact switch | J533 | Data bus diagnosis interface |
| F256 | Tailgate locking unit | J623 | Engine control unit |
| F266 | Bonnet contact switch | J741 | Dual inverter relay |
| G303 | Interior monitor sender/receiver module 1 | C-K | Convenience CAN data bus |
| G305 | Interior monitor sender/receiver module 2 | C-A | Drive train CAN data bus |

Convenience and safety electronics

Interior monitor

The interior monitor comprises interior monitor sender/receiver module 1 (master) and interior monitor sender/receiver module 2 (slave). Both modules operate according to the ultrasonic principle.

The master monitors and regulates communication between the interior monitor sender/receiver modules and also communicates via a bidirectional interface with the convenience system central control unit which releases the alarm.

When the anti-theft alarm system is primed, the interior monitor sender/receiver modules register an alarm case if a movement is sensed in the vehicle interior.

If the additional heater is switched on or if the Climatronic residual heat function is active, the response sensitivity of the interior monitor is reduced so that the air flow does not trigger false alarms.

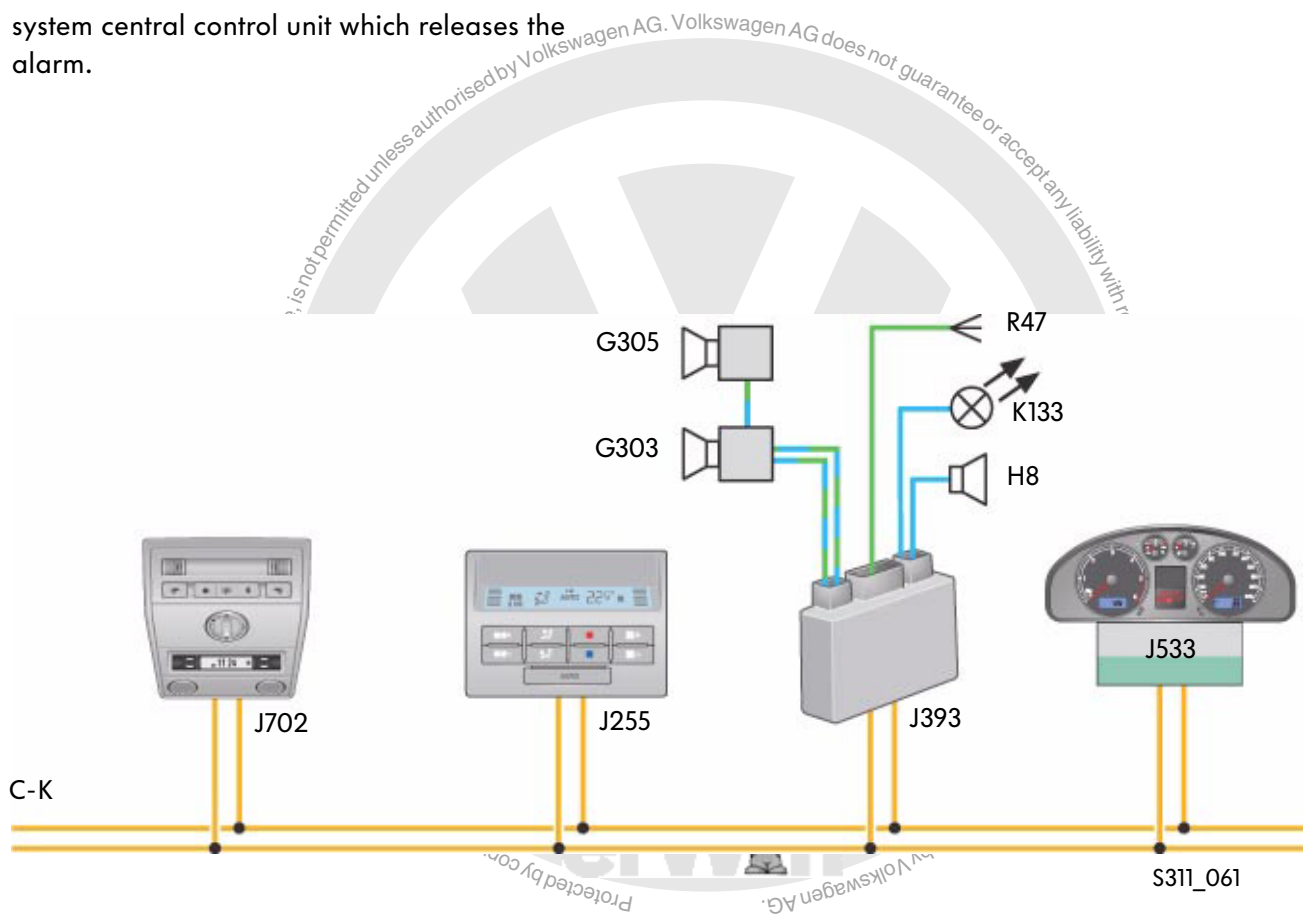

Legend

- | | | | |
|------|----------------------------------------------------|------|----------------------------------------------------|
| G303 | Interior monitor sender/receiver module 1 (master) | J533 | Data bus diagnosis interface |
| G303 | Interior monitor sender/receiver module 2 (slave) | J702 | Roof display unit |
| H8 | Alarm horn | K133 | Central locking warning lamp |
| J255 | Climatronic control unit | R47 | Central locking and anti-theft alarm system aerial |
| J393 | Convenience system central control unit | C-K | Convenience CAN data bus |

Tow-away protection

The vehicle inclination sender G384 is located in the interior monitor sender/receiver module 1 (master).

It registers the angle of inclination of the vehicle between -25° and $+25^\circ$ in the longitudinal and transverse directions. When the anti-theft alarm system is primed, the current angle of inclination is stored. Through continuous cyclical comparison between the stored angle of inclination and the current angle of inclination, the vehicle inclination sender triggers an alarm if a change is detected.



You will find a functional description in SSP 273 "The Phaeton Convenience and Safety Electronics"



S31I_031

Deactivation

The interior monitor and the tow-away protection can be deactivated via the interior monitor switch E183.

For this purpose, switch E183 must be operated after switching off the ignition and before priming the anti-theft alarm system.

Deactivation is cancelled if the ignition is switched on after operating switch E183 or if the anti-theft alarm system has been deactivated.

Self-test

Interior sensor errors are indicated by the interior monitoring deactivation warning lamp.

If an error occurs, the warning lamp flashes for a maximum period of 60 seconds after the ignition is switched on and if the anti-theft alarm system is deactivated.

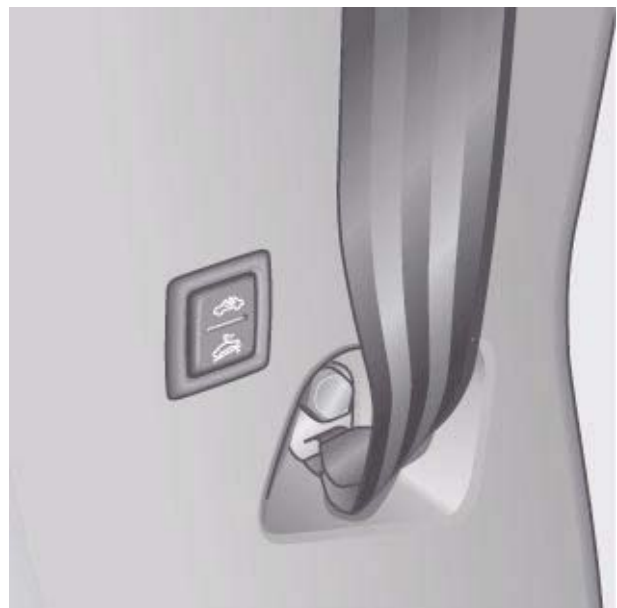

S31I_100

Convenience and safety electronics

Electrically operated sliding door

Operation

The electrically operated sliding door can be opened or closed by operating the interior or exterior door handles, the sliding door button E442 or the right sliding door button E482 in the instrument panel, or by pressing the corresponding button on the radio wave remote control.

"Open/close"
left sliding door button

"Open/close"
right sliding door button



S311_055

"Deactivate" electrical sliding door button

Sliding door control unit

An electrically operated sliding door can be installed optionally on the left and/or right hand sides of the vehicle.

The sliding door is controlled by the sliding door control unit J558 and/or the right sliding door control unit J731.

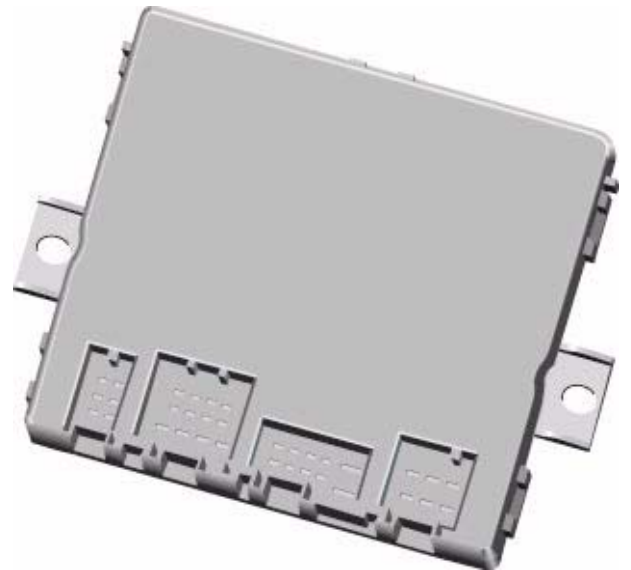

S311_027

Sliding door sender unit G477

The sliding door sender unit transmits the door handle signals, the lock states "locked and Safe", as well as the latched states of the door locks wirelessly to the sliding door control unit.

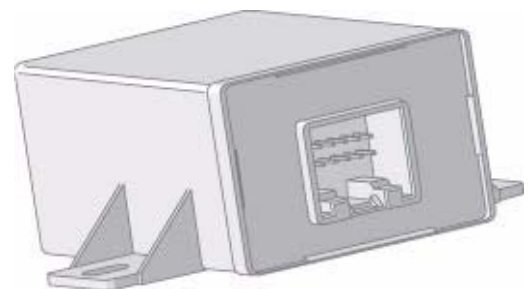

S311_029

Data transfer

Data is transmitted without wire between the sliding door control unit J558/J731 and the left/right sliding door sender unit G477.

This inductive data transfer system supplies the sender unit with energy from the sliding door control unit via a 125 kHz signal. Information is exchanged between both control units by modulating this signal.

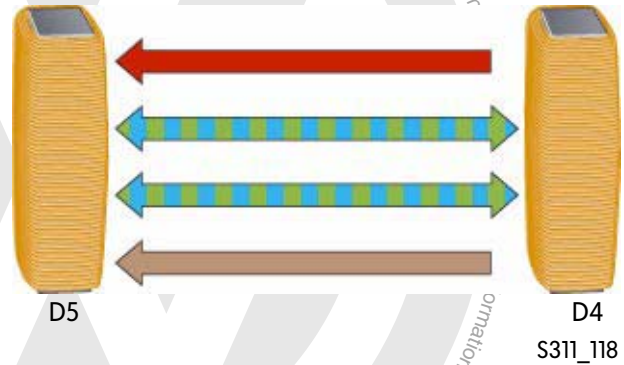

Data is transferred via sliding door magnetic coil D5 on the upper roller guide and sliding door reader coil D4 on the upper guide rail.

Upper roller guide

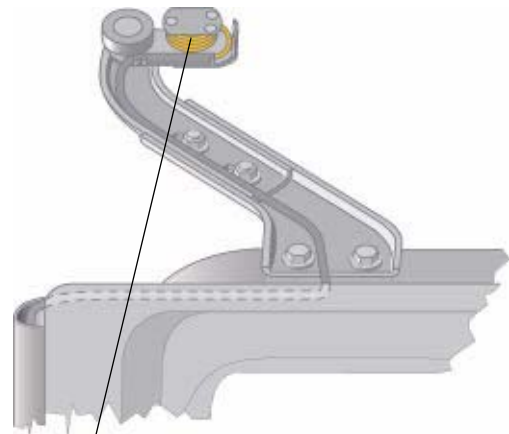

S311_026

Upper guide rail

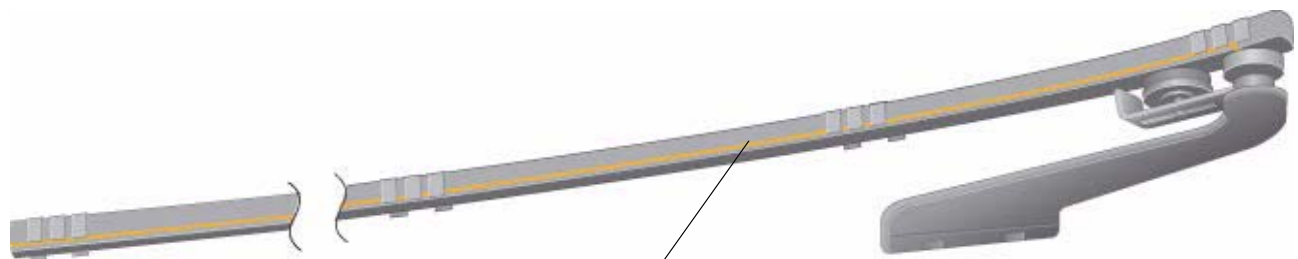

S311_028

Sliding door reader coil D4

Convenience and safety electronics

Overview of components

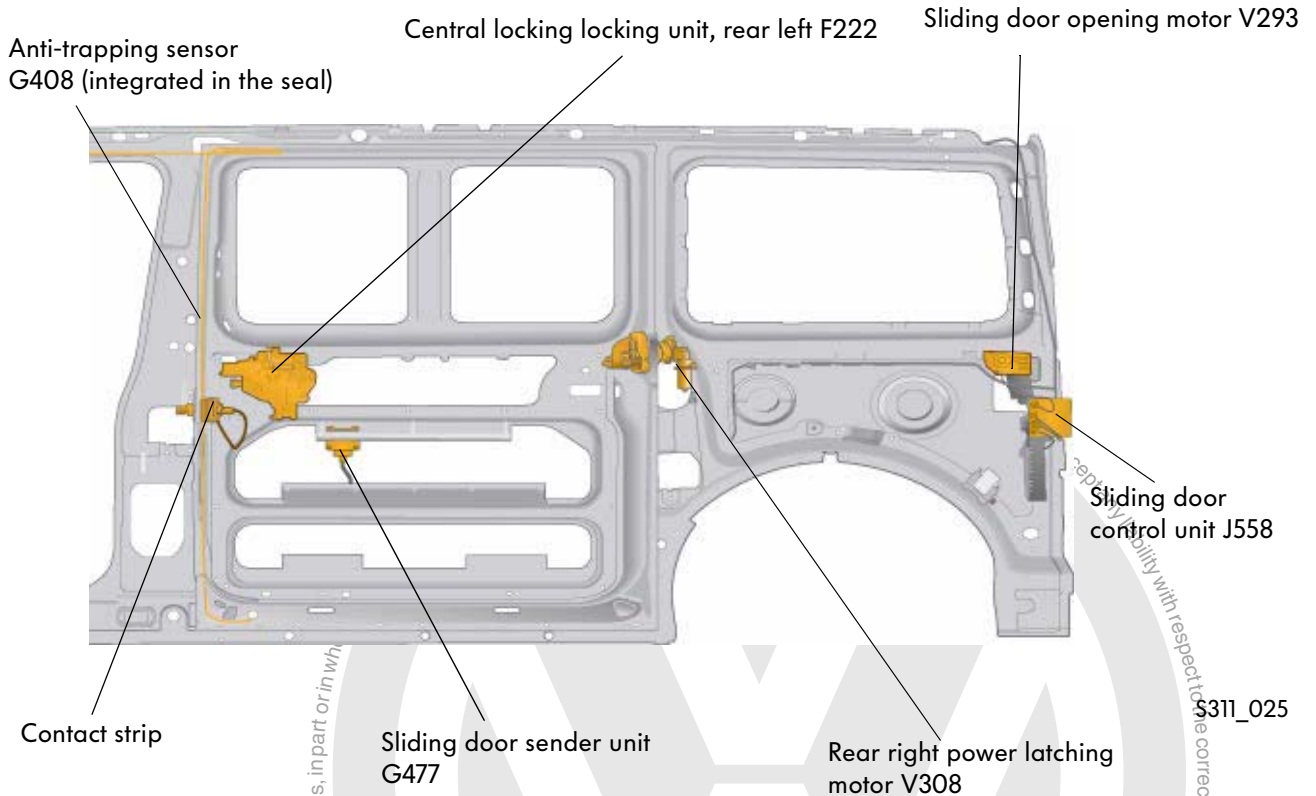

Anti-trapping protection

Passive anti-trapping protection

If the engine speed of the sliding door opening motor decreases sharply during the opening or closing movements of the sliding door, and this decrease has not been requested by the sliding door control unit, an obstruction may have occurred.

If this occurs while the sliding door is closing, the sliding door will move back to the fully-open position. If this occurs while the sliding door is opening, the sliding door will stop moving.

In addition, opening or closing the sliding door is inhibited at speeds of over 3 kph.

Active anti-trapping protection

Integrated in the sliding door seal is a protective moulding whose ohmic resistance changes under pressure. While the sliding door is closing, the sliding door control unit monitors the resistance continuously. If the default value changes, an obstruction has occurred and the sliding door will be fully reopened.

Deactivating the anti-trapping protection function

If the sliding door button is held down while the sliding door is opening or closing, the active and passive anti-trapping protection functions will be deactivated.

Sliding door opening motor V293

The sliding door opening motor is activated by the sliding door control unit. It drives the sliding door operating cable via an integrated gear.



S311_054

Rear right power latching motor V308

To assist opening and closing, the electrical sliding door has a power latching system.

Power latching is controlled by the sliding door control unit. Opening and closing of the door lock is registered via the door contact switch, and the power latching motor is activated until the power latching system contact switch signals the completion of the latching operation.

For safety reasons, the latching operation is limited in time.

If no electrical sliding door is installed, the power latching (system) function is controlled by a separate control unit.

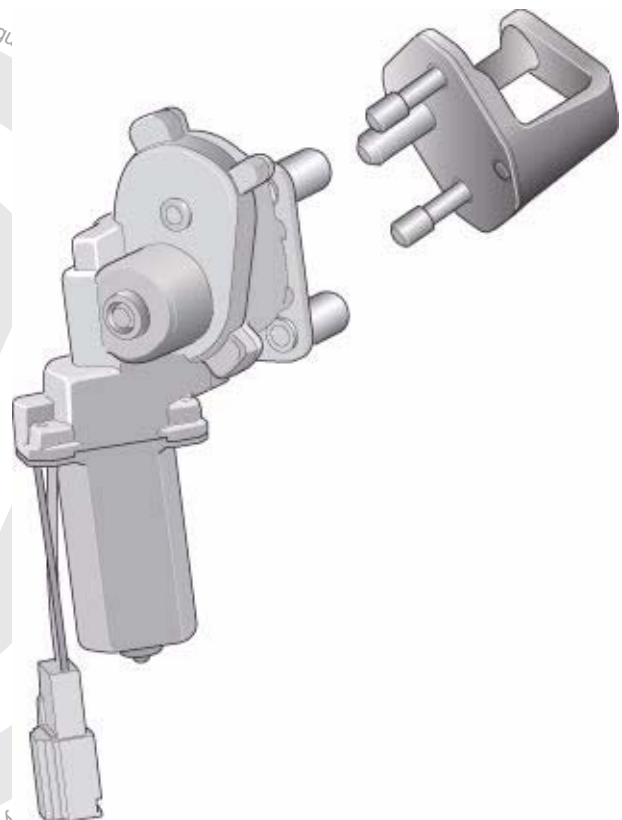

S311_031



You will find a functional description of the mechanism in SSP 310 "The Transporter 2004".

Convenience and safety electronics

Function chart

| Function | Operator controls | Activation conditions | Deactivation conditions |
|---------------------------------------------------------------------------------------|--------------------------------------------------------------------------------------------------------------------------------------------------------------------------------------------|----------------------------------------------------------------------------------------------------------------------------------------------------------------------------------------------------------------------------------------------------------------------------------------------------------------------------------------------------------------------------------------------------------------------------------------------------------------------------------------|---------------------------------------------------------------------------------------------------------------------------------------------------------------------------------------------------------------------------|
| <ul style="list-style-type: none"> Opening the electrical sliding door | <ul style="list-style-type: none"> Interior door handle Exterior door handle Electrical sliding door open/close button Radio wave remote control | <ul style="list-style-type: none"> Door is unlocked and the electrical sliding door has not been deactivated by the deactivation switch and the interior door handle for opening door has been operated or the exterior door handle for opening door has been operated or the open/close electrical sliding door button for opening door has been operated or the radio wave remote control opening door has been operated | <ul style="list-style-type: none"> the door has reached fully-open position or the anti-trapping protection does not operate or the road speed is higher than 3 kph |
| <ul style="list-style-type: none"> Closing the electrical sliding door | <ul style="list-style-type: none"> Interior door handle Exterior door handle Open/close electrical sliding door button radio wave remote control | <ul style="list-style-type: none"> the electrical sliding door has not been deactivated by the deactivation switch and the interior door handle for closing door has been operated or the exterior door handle for closing door has been operated or the open/close electrical sliding door button for closing door has been operated or the radio wave remote control closing door has been operated | <ul style="list-style-type: none"> the sliding door is closed or the anti-trapping protection does not operate door opened to fully-open position or the road speed is higher than 3 kph |

Functional diagram

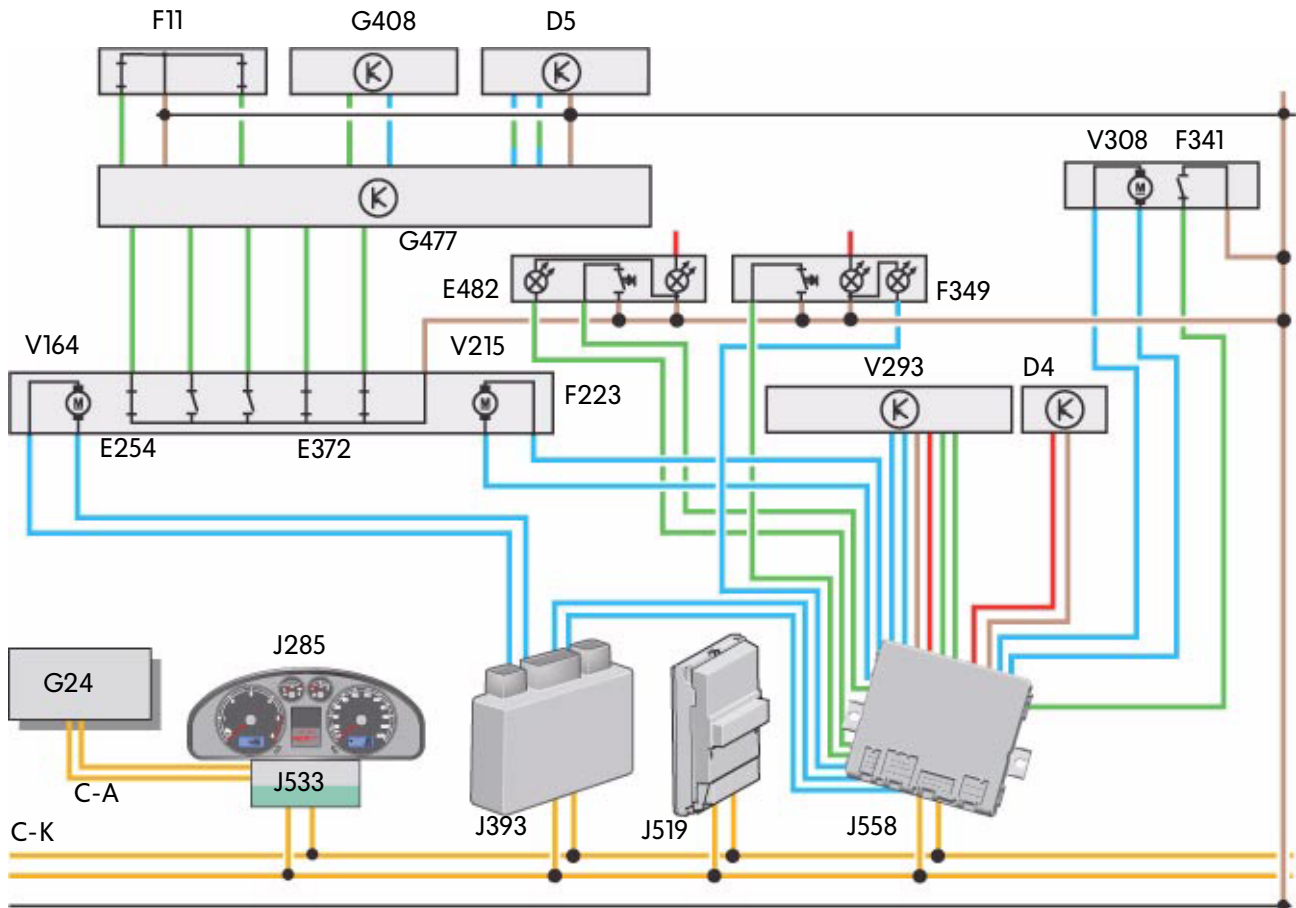

S311_077

Legend

| | | | |
|------|--------------------------------------------------------------|------|------------------------------------------------|
| D4 | Sliding door reader coil | G24 | Tachograph |
| D5 | Sliding door magnetic coil | J285 | Control unit with display in dash panel insert |
| E254 | Child safety lock switch | J393 | Convenience system central control unit |
| E372 | Exterior door handle central locking button, rear right door | J519 | Onboard power supply control unit |
| E482 | Right sliding door button | J533 | Data bus diagnosis interface |
| F11 | Rear right door contact switch | J558 | Sliding door control unit |
| F341 | Rear right door power latching system contact switch | V164 | Central locking motor (Safe), rear right door |
| F349 | Deactivation button for sliding door | V215 | Central locking motor (Lock), rear right door |
| F223 | Central locking locking unit, rear right | V293 | Sliding door opening motor |
| G408 | Anti-trapping sensor | V308 | Rear right power latching motor |
| G477 | Sliding door sender unit | C-K | Convenience CAN data bus |
| | | C-A | Drive train CAN data bus |

Convenience and safety electronics

Multi-function steering wheel

Operator controls

The cruise control system (CCS), the audio system and, depending on the variant, the telephone, can be operated by the buttons on the multi-function steering wheel.

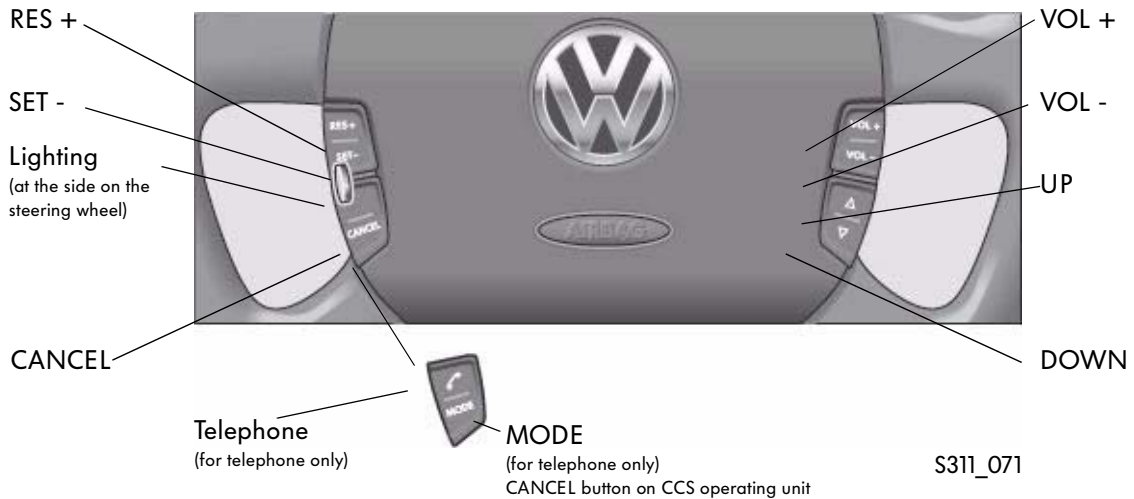

Operating the audio system, the cruise control system and the telephone

The nominal speed can be changed and reset with the RES+ button.

The nominal speed can be stored and reduced with the SET button.

The cruise control system can be temporarily deactivated with the CANCEL button.

Visual feedback is via the multi-function display in the control unit with display in the dash panel insert is required for the "UP", "Down" and "Mode" buttons. If no visual feedback is possible due to a display with an elevated, higher priority, no feedback is provided. However, the function is executed.

The "VOL +" and "VOL -" buttons can be used to adjust the volume setting at any time without visual feedback when the audio system is active or during a telephone call.

When the "Mode" button is pressed for the first time, the current function assignments of the "UP" and "DOWN" button appear in the multi-function display. To change to a different function, press the button again within 5 seconds. The new function is displayed for approx. 5 seconds.

A telephone call can be accepted, set up or ended by pressing the "Telephone" button.

Signal sequence

The signals from the control buttons are transmitted from the steering wheel button module to the multi-function steering wheel control unit J453. The multi-function steering wheel control unit converts the signal to CAN data bus messages and sends them to the convenience CAN data bus. The control unit with display in dash panel insert, the radio and the telephone/telematics control unit can read these messages and execute the operator's command.

The signals for operating the cruise control system are transmitted via conventional (discrete) cable connections.

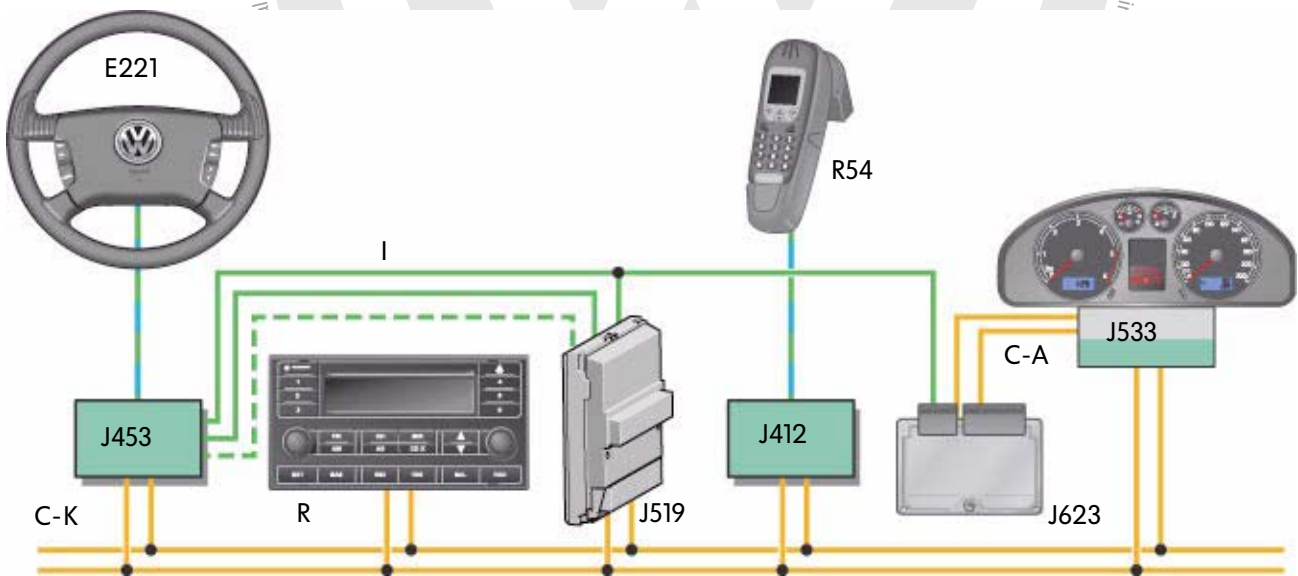

S311_076

Legend

| | | | |
|------|-----------------------------------------------------|-----|---------------------------------------------|
| E221 | Operating unit in steering wheel | R | Radio |
| J412 | Mobile telephone operating electronics control unit | R54 | Mobile telephone |
| J453 | Multi-function steering wheel control unit | C-K | Convenience CAN data bus |
| J519 | Onboard power supply control unit | C-A | Drive train CAN data bus |
| J533 | Data bus diagnosis interface | I | Discrete messages |
| J623 | Engine control unit | | (broken line: not available with telephone) |

Convenience and safety electronics

Multi-function steering wheel for audio and CCS operation

The signals from the control buttons are registered by the operating unit in the steering wheel and sent via a single-wire bus connection to the multi-function steering wheel control unit. The multi-function steering wheel control unit sends this signal to the convenience CAN data bus. The cruise control system signals are relayed via three separate lines to the onboard power supply control unit.

The On/Off signals from the cruise control system switch are transmitted along a conventional cable connector to the onboard power supply control unit, the multi-function steering wheel control unit and the engine control unit.

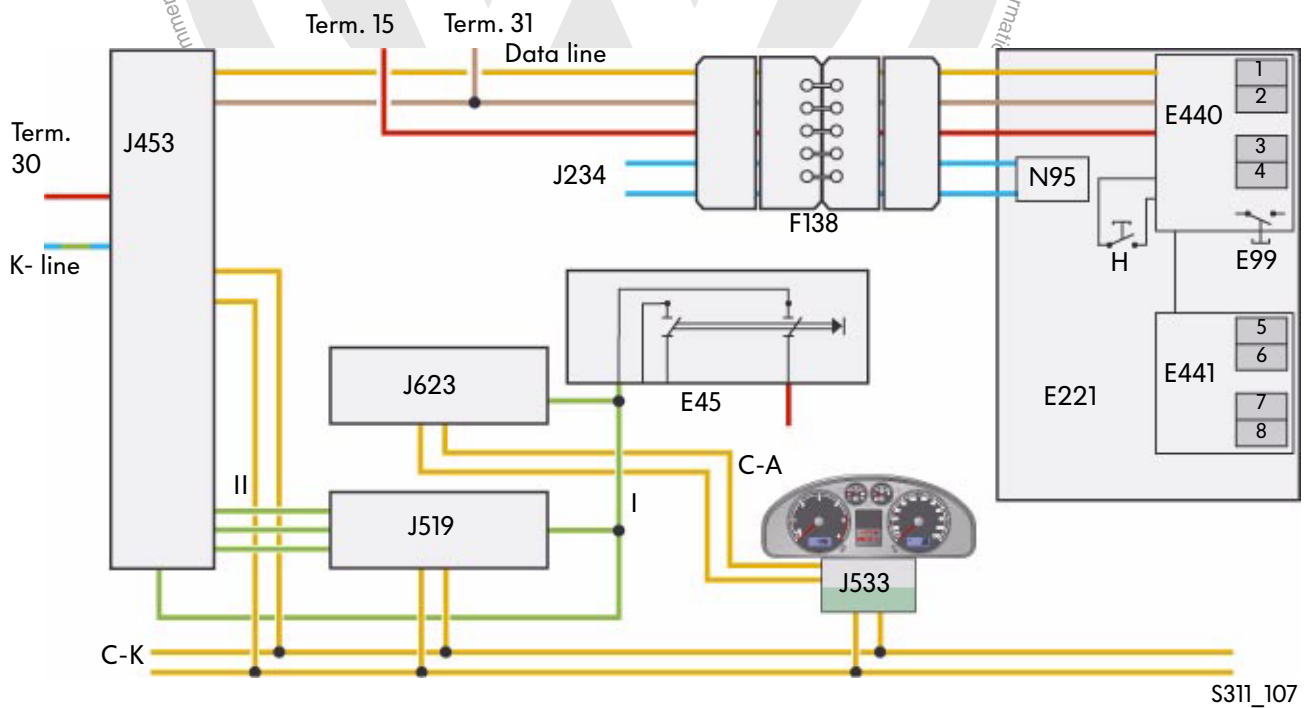

Legend

- | | | | |
|------|--------------------------------------------------|------|---------------------------------------------------|
| E45 | Cruise control system switch | E441 | Multi-function buttons on right of steering wheel |
| E99 | Operating unit illumination regulator | F138 | Airbag coil connector |
| E221 | Operating unit in steering wheel | H | Horn plate |
| E440 | Multi-function buttons on left of steering wheel | J234 | Airbag control unit |

Multi-function steering wheel for audio, CCS and telephone operation

The signals from the control buttons are transferred in the same way as the signals from the multi-function steering wheel for the audio and cruise control systems.

The cruise control system signals are, however, relayed via two separate lines to the onboard power supply control unit.

The On/Off and "CANCEL" signals from the cruise control system switch are transmitted along a conventional cable connector to the onboard power supply control unit, the multi-function steering wheel control unit and to the engine control unit. In this variant, the "CANCEL" button is located on the cruise control system switch.

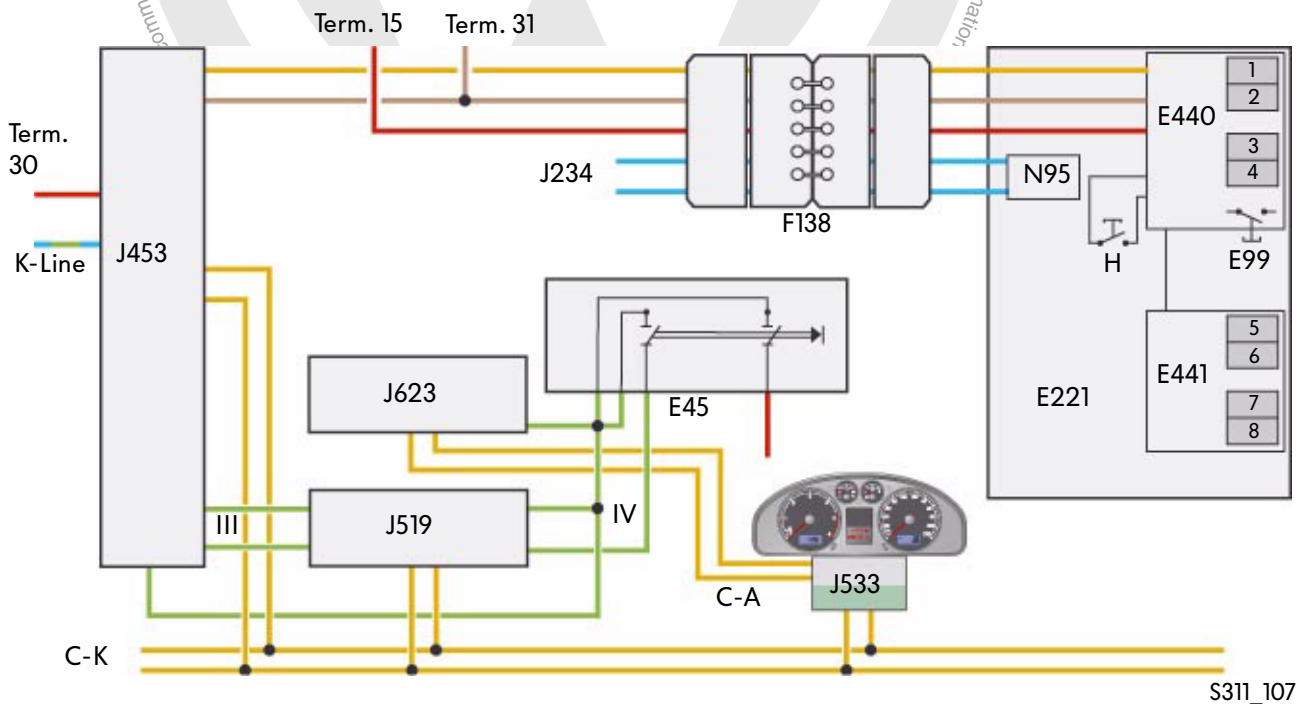

- J453 Multi-function steering wheel control unit for audio
- J519 Onboard power supply control unit
- J533 Data bus diagnosis interface
- J623 Engine control unit

- N95 Airbag igniter, driver side
- C-K Convenience CAN data bus
- C-A Drive train CAN data bus

Discrete button signals

- | I | II | III | IV |
|--------|--------|--------|------|
| On/Off | Cancel | On/Off | SET- |
| | SET- | Cancel | RES+ |
| | RES+ | | |

Convenience and safety electronics

Cruise control system (CCS)

Cruise control system without multi-function steering wheel

In vehicles without a multi-function steering wheel, the cruise control system can only be operated via the cruise control system switch E45 and the cruise control system (CCS) button E227. The switches are connected to the onboard power supply control unit and the engine control unit.

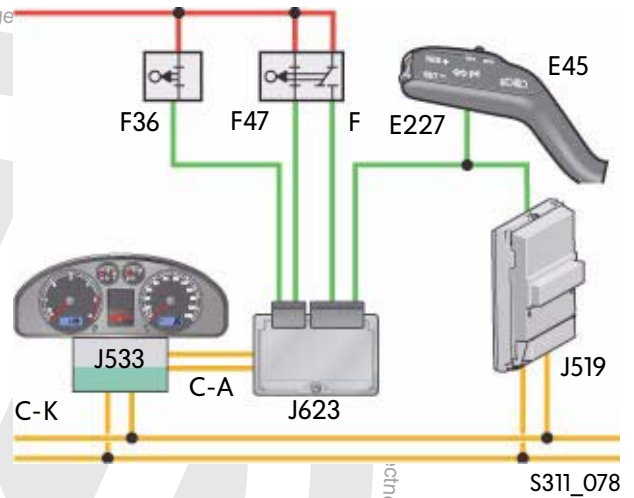

Cruise control system with multi-function steering wheel (CCS/audio)

Vehicles equipped with a multi-function steering wheel for operating the cruise control system and the audio system have only a cruise control system switch on the turn signal switch, it is connected directly to the onboard power supply control unit, the multi-function steering wheel control unit for audio and the engine control unit. The SET-, RES+ and CANCEL signals from the operating unit in steering wheel are transmitted via the conventional cable connection to the onboard power supply control unit and relayed from here via the convenience CAN data bus and the data bus diagnostic interface to the engine control unit.

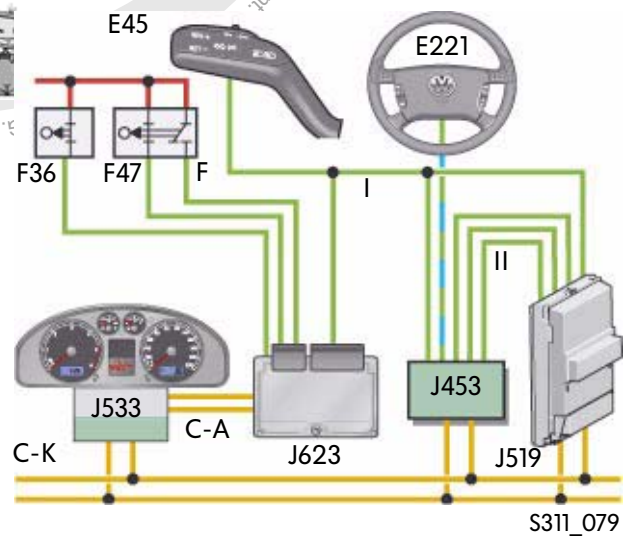

Legend

- E45 Cruise control system switch
- E221 Operating unit in steering wheel
- E227 Cruise control system (CCS) button
- F Brake light switch
- F36 Clutch pedal switch
- F47 Cruise control system brake pedal switch

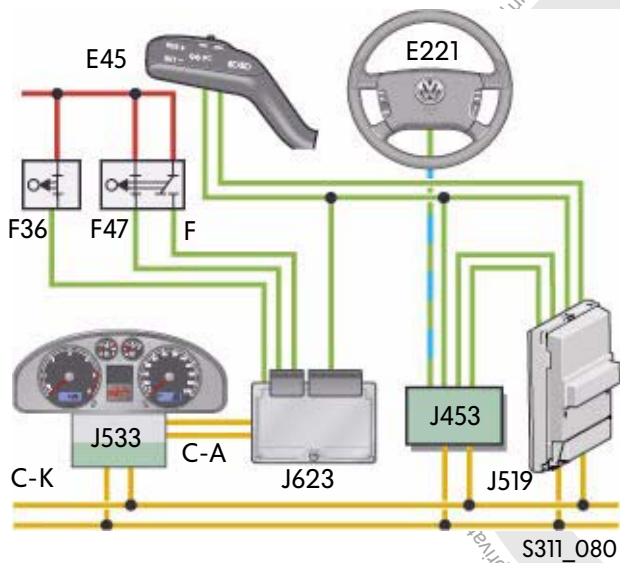

Cruise control system with multi-function steering wheel (CCS/audio/telephone)

If a multi-function steering wheel for operating the cruise control system, the audio system and the telephone is fitted, the cruise control system switch and the Cancel button are located on the turn signal switch.

The On and Off switch is connected to the onboard power supply control unit, the multi-function steering wheel control unit for audio and the engine control unit. The Cancel button is only connected to the onboard power supply control unit.

The SET- and RES+ signals from the operating unit in the steering wheel are transferred along conventional cable connections to the onboard power supply control unit, and relayed from here via the convenience CAN data bus and the data bus diagnostic interface to the engine control unit.

- J453 Multi-function steering wheel control unit for audio
- J519 Onboard power supply control unit
- J533 Data bus diagnosis interface
- J623 Engine control unit
- C-K Convenience CAN data bus
- C-A Drive train CAN data bus



The multi-function steering wheel is only available in combination with radio systems which can communicate via the CAN data bus or the navigation system and in the Multivan.

Radio/telephone/navigation

Radio systems

Alpha radio

The Alpha radio comprises, as an audio source, a tuner, an internal amplifier and a compact cassette player, and is fitted in commercial vehicles only.

A bass loudspeaker and a mid-range/treble loudspeaker are connected to the two output channels.

The audio signal is conditioned by the internal amplifier. It is not possible to connect an external amplifier.

The Alpha radio offers the possibility to connect the mobile telephone operating electronics control unit J412 or a telephone.

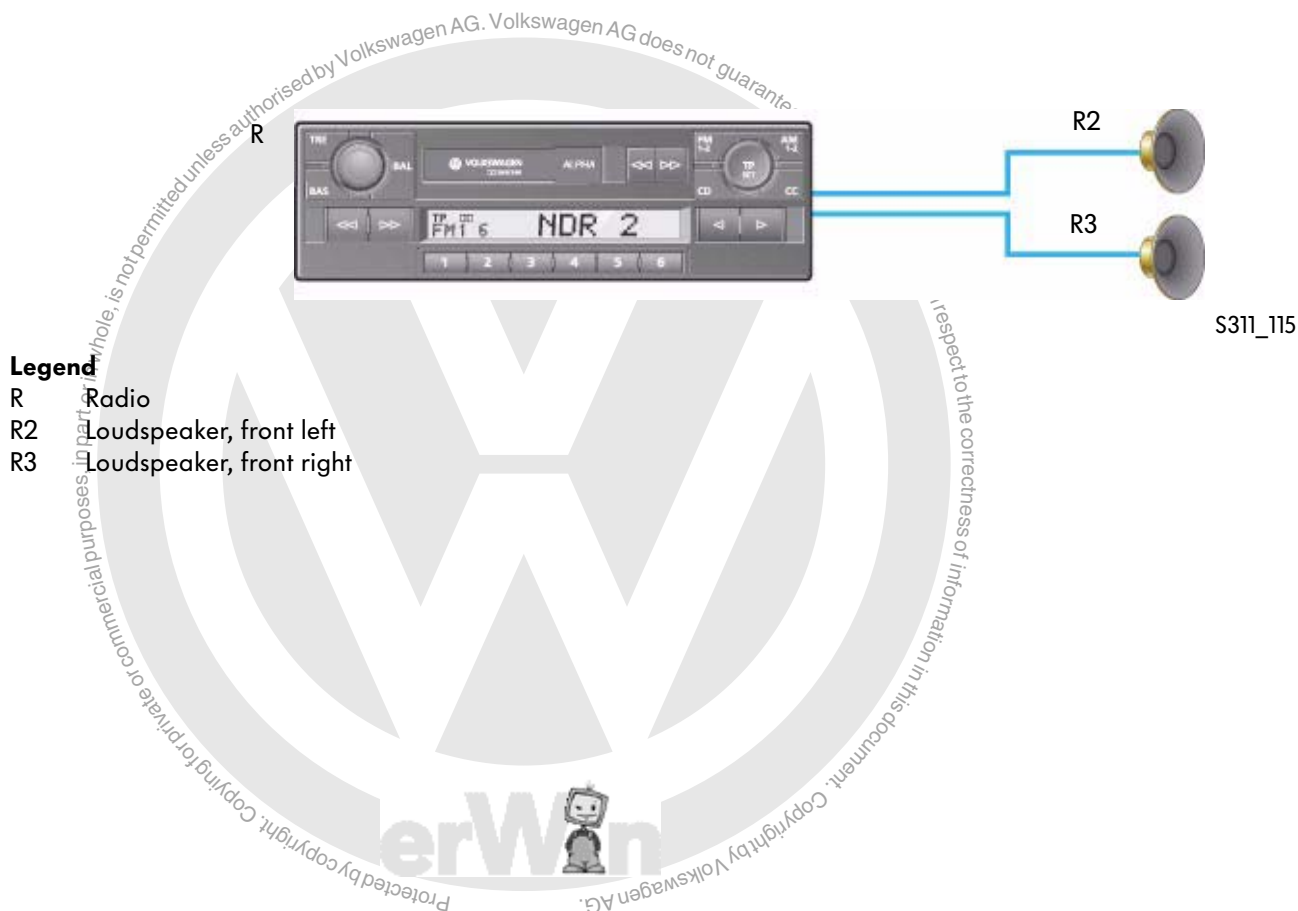

Beta radio

The Beta radio comprises, as an audio source, a tuner, an internal amplifier and a compact cassette player. Like the Alpha radio, it is only available in commercial vehicles.

A bass loudspeaker and a mid-range/treble loudspeaker are connected to the two output channels.

The audio signal is conditioned by the internal amplifier. It is not possible to connect an external amplifier.

The Beta radio offers the possibility to connect a telephone or the mobile telephone operating electronics control unit, as well as an external CD changer.

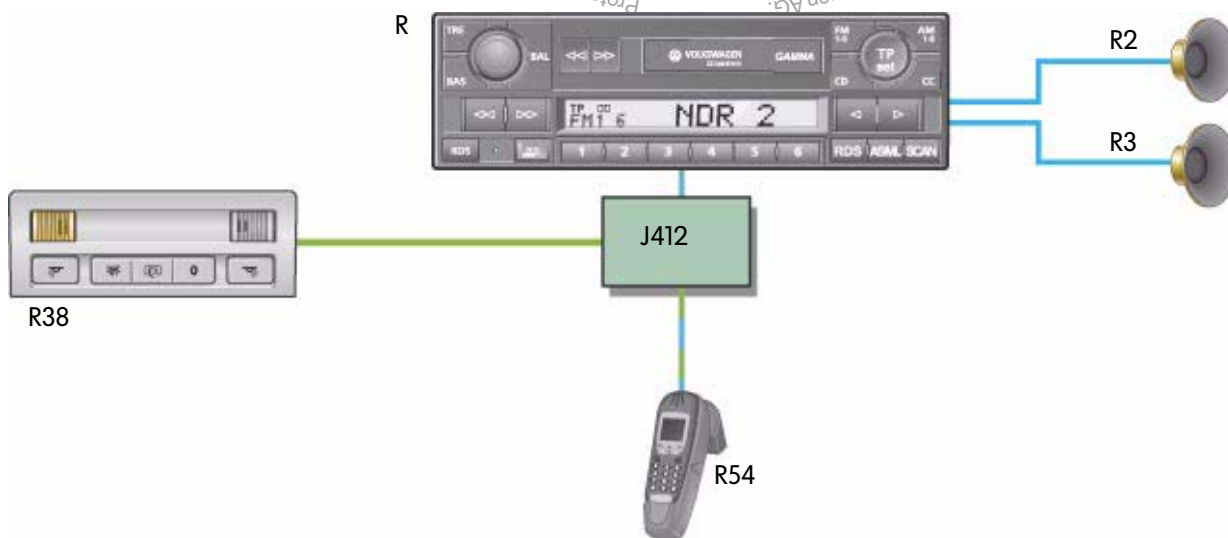

S311_087

Legend

- | | | | |
|------|-----------------------------------------------------|-----|--------------------------|
| J412 | Mobile telephone operating electronics control unit | R3 | Loudspeaker, front right |
| R | Radio | R54 | Mobile telephone |
| R2 | Loudspeaker, front left | R38 | Telephone microphone |

Radio/telephone/navigation

Gamma radio

The Gamma radio has, as an audio source, a tuner, an internal amplifier and a compact cassette player. It is possible to connect an external CD player or a CD changer. This radio is only fitted only in right-hand drive vehicles in Europe.

The audio signal is conditioned by the internal amplifier. It is not possible to connect an external amplifier.

The Gamma radio offers the possibility to connect the mobile telephone operating electronics control unit or a telephone.

A bass loudspeaker and a mid-range/treble loudspeaker is connected via a frequency switch to each of the front output channels as well as to each of the rear output channels.



S311_089

Legend

J412 Mobile telephone operating electronics control unit
 R Radio
 R2 Loudspeaker, front left
 R3 Loudspeaker, front right

R4 Loudspeaker, rear left
 R5 Loudspeaker, rear right
 R38 Telephone microphone
 R54 Mobile telephone

MCD radio navigation system (Mono Chrome Display)

The MCD radio/navigation system comprises, as an audio source, a tuner, an internal amplifier and a Compact Disc Player. It is only fitted in commercial vehicles.

The radio/navigation system MCD also offers the possibility to connect external CD changer, a telephone or the mobile telephone operating electronics control unit.

A bass loudspeaker and a mid-range/treble loudspeaker is connected to both output channels. It is not possible to connect an external amplifier.

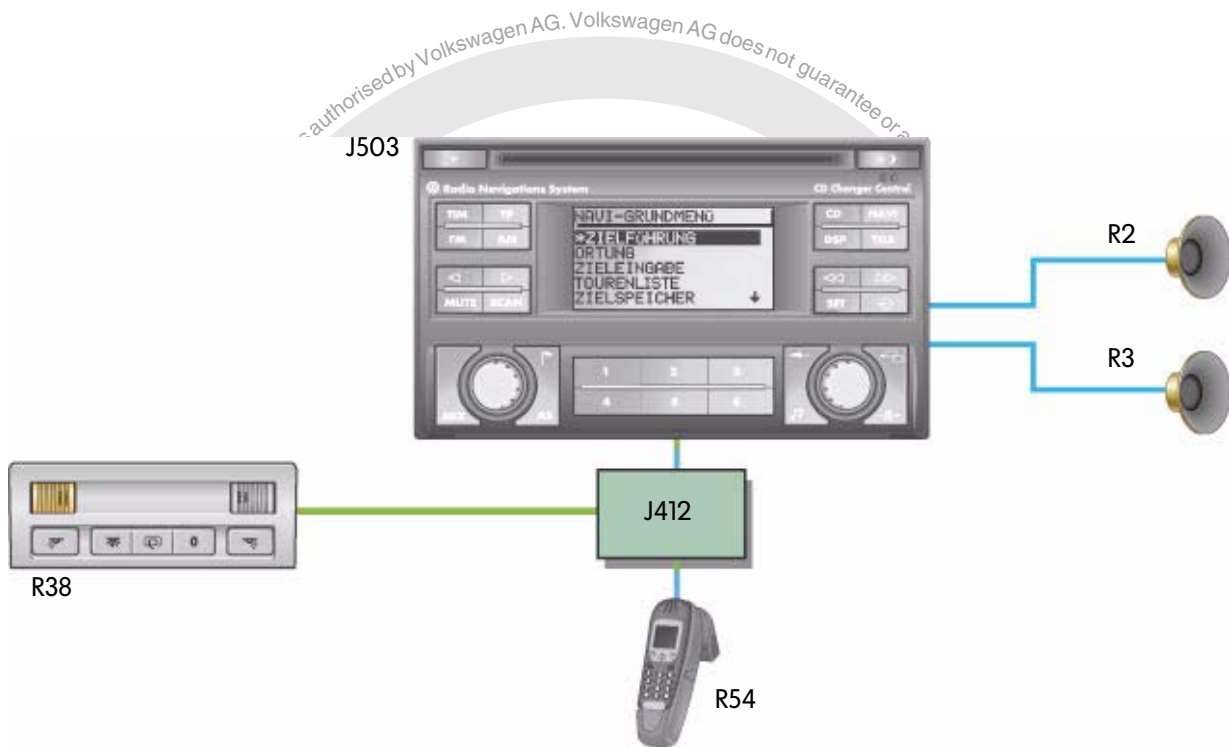

S311_116

Legend

- J412 Mobile telephone operating electronics control unit
- J503 Control unit with display for radio and navigation
- R2 Loudspeaker, front left
- R3 Loudspeaker, front right
- R38 Telephone microphone
- R54 Mobile telephone

Radio telephone, navigation

Delta radio

The Delta radio comprises, as an audio source, a tuner, an internal amplifier and a compact disc player. It is possible to connect an external CD changer.

The audio signal is conditioned by the internal amplifier. Depending on how the radio is encoded, the loudspeakers can be connected directly or via an analogue 8-channel amplifier.

If the loudspeakers are connected directly, a bass loudspeaker and a mid-range/treble loudspeaker are supplied at each of the front output channels and at each of the rear output channels.

The Delta radio is not fitted in commercial vehicles.

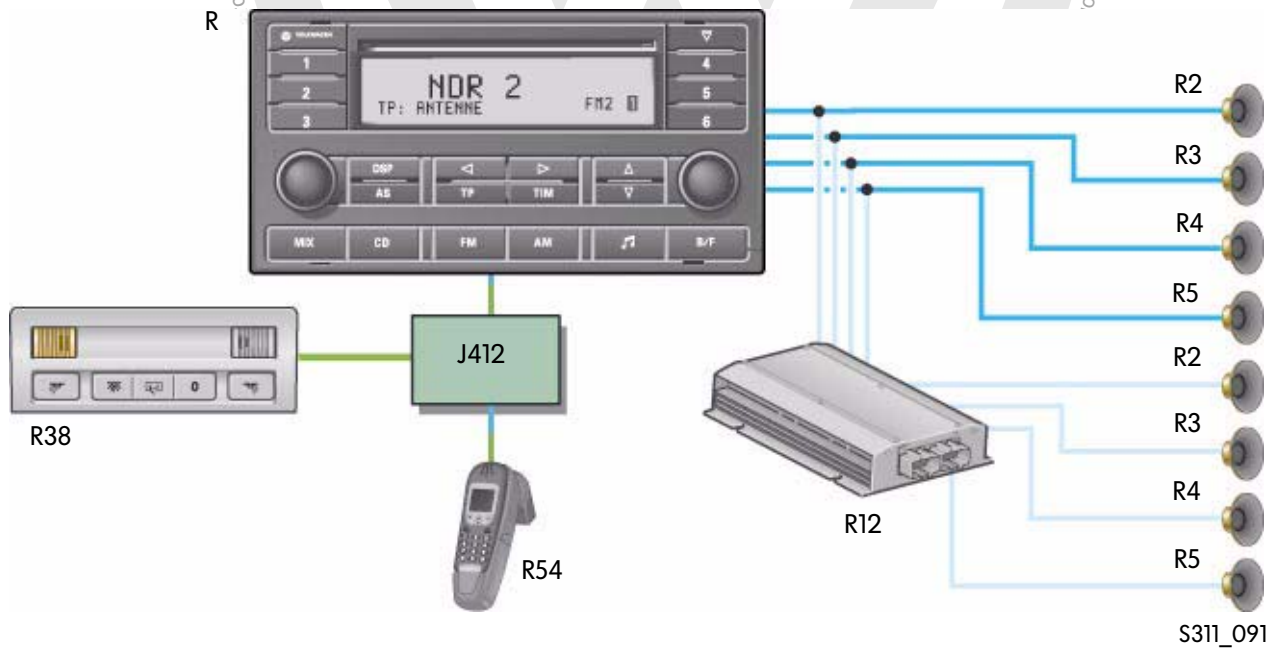

Legend

J412 Mobile telephone operating electronics control unit
 R Radio
 R2 Loudspeaker, front left
 R3 Loudspeaker, front right

R4 Loudspeaker, rear left
 R5 Loudspeaker, rear right
 R12 Amplifier
 R38 Telephone microphone
 R54 Mobile telephone
 Light-blue or dark-blue connection to loudspeakers depending on specification

Radio/navigation system 2

Radio/navigation system 2 comprises, as an audio source, a tuner, an internal amplifier and a compact disc player. It is possible to connect an external CD changer. This system is not fitted in commercial vehicles.

The audio signal is conditioned by the internal amplifier. Depending on how the radio is encoded, the loudspeakers can be connected directly or via a digital 12-channel amplifier.

If the loudspeakers are connected directly, a bass loudspeaker and a mid-range/treble loudspeaker are supplied at each of the front output channels and at each of the rear output channels.

The operator settings for volume, sound, balance and fading are transferred from the control panel via the convenience CAN data bus to the amplifier.

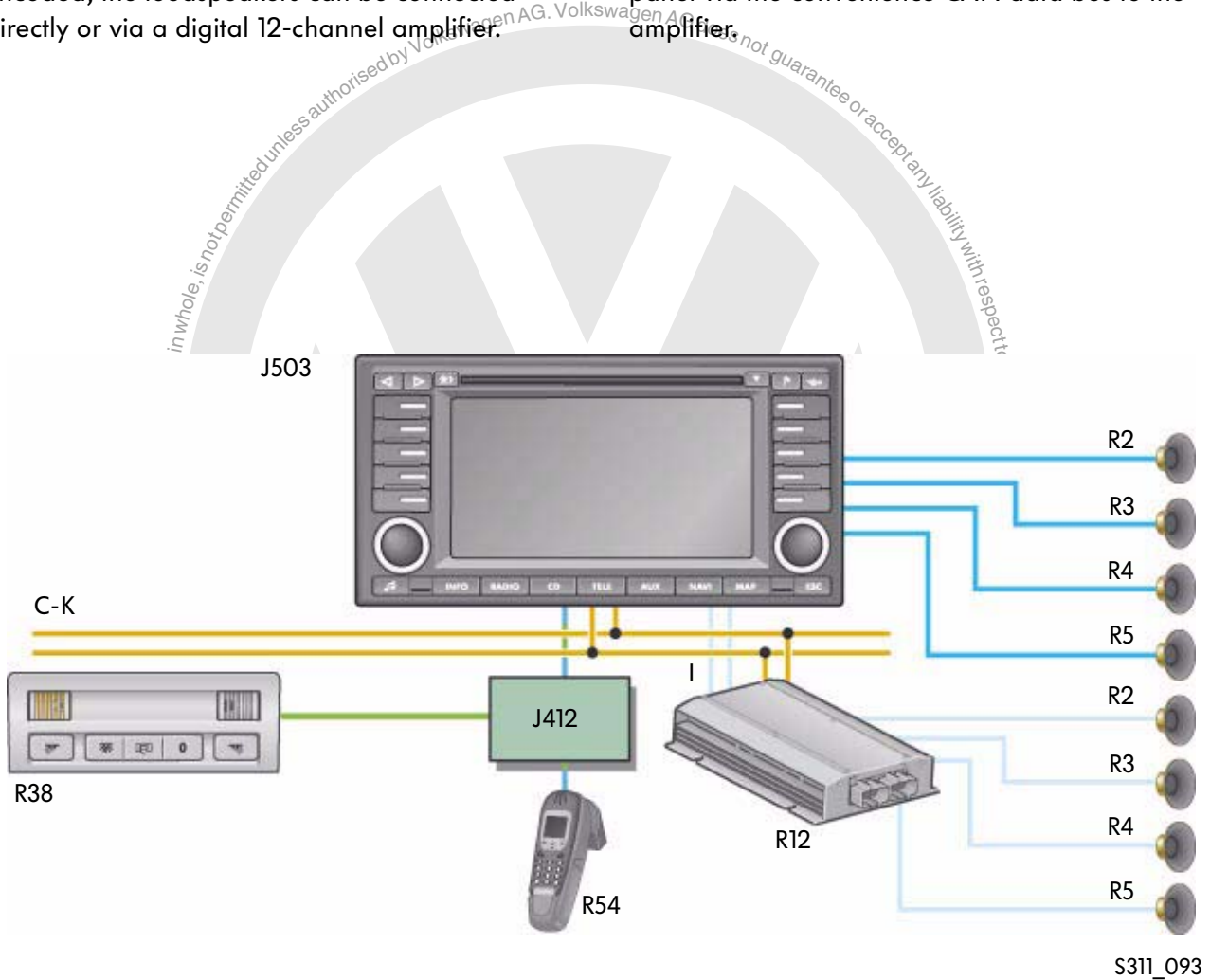

Legend

J412 Mobile telephone operating electronics control unit
 J503 Control unit with display for radio and navigation
 R2 Loudspeaker, front left
 R3 Loudspeaker, front right
 R4 Loudspeaker, rear left
 R5 Loudspeaker, rear right

R12 Amplifier
 R38 Telephone microphone
 R54 Mobile telephone
 C-K Convenience CAN data bus
 I Line- Out
 Pale-coloured connections are dependent on specification

Radio/telephone/navigation

Digital Voice Enhancement (DVE)

Fitting location

The voice enhancement control unit J656 is located under the front passenger seat.

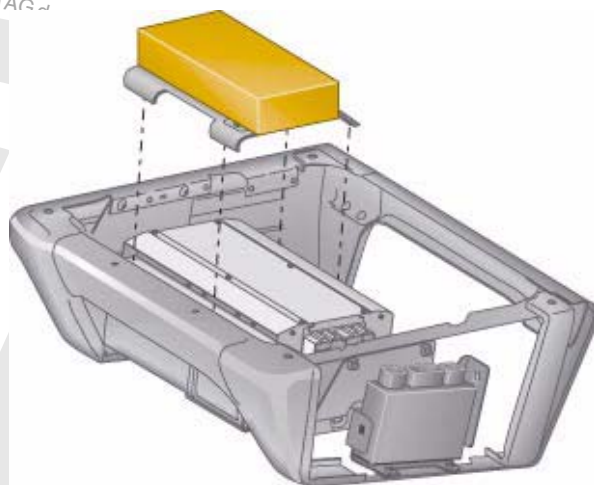

S311_095

Microphone R140 - R145

For occupant voice recording by the voice enhancement control unit, six microphones are fitted in the vehicle headlining.



S311_096

Balance control R6

The balance control is located in the instrument panel. It adjusts the balance between left and right loudspeakers and controls the voice component of the loudspeaker output signal.

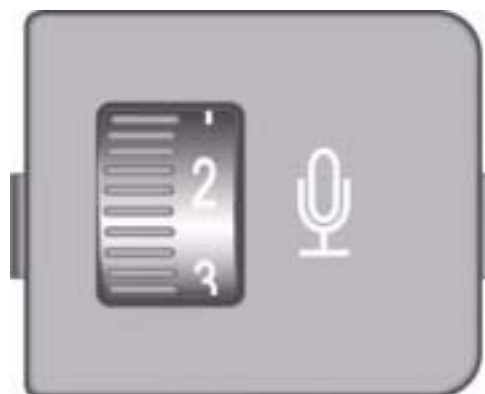

S311_097

Loudspeakers

Voice output is through the loudspeakers of the audio system.

To avoid feedback, the speech of the front occupants is transmitted only to the rear and the speech of the rear occupants is transmitted only to the front. The speech of mid-vehicle occupants is transmitted both to the front and to the rear.

Overview of components

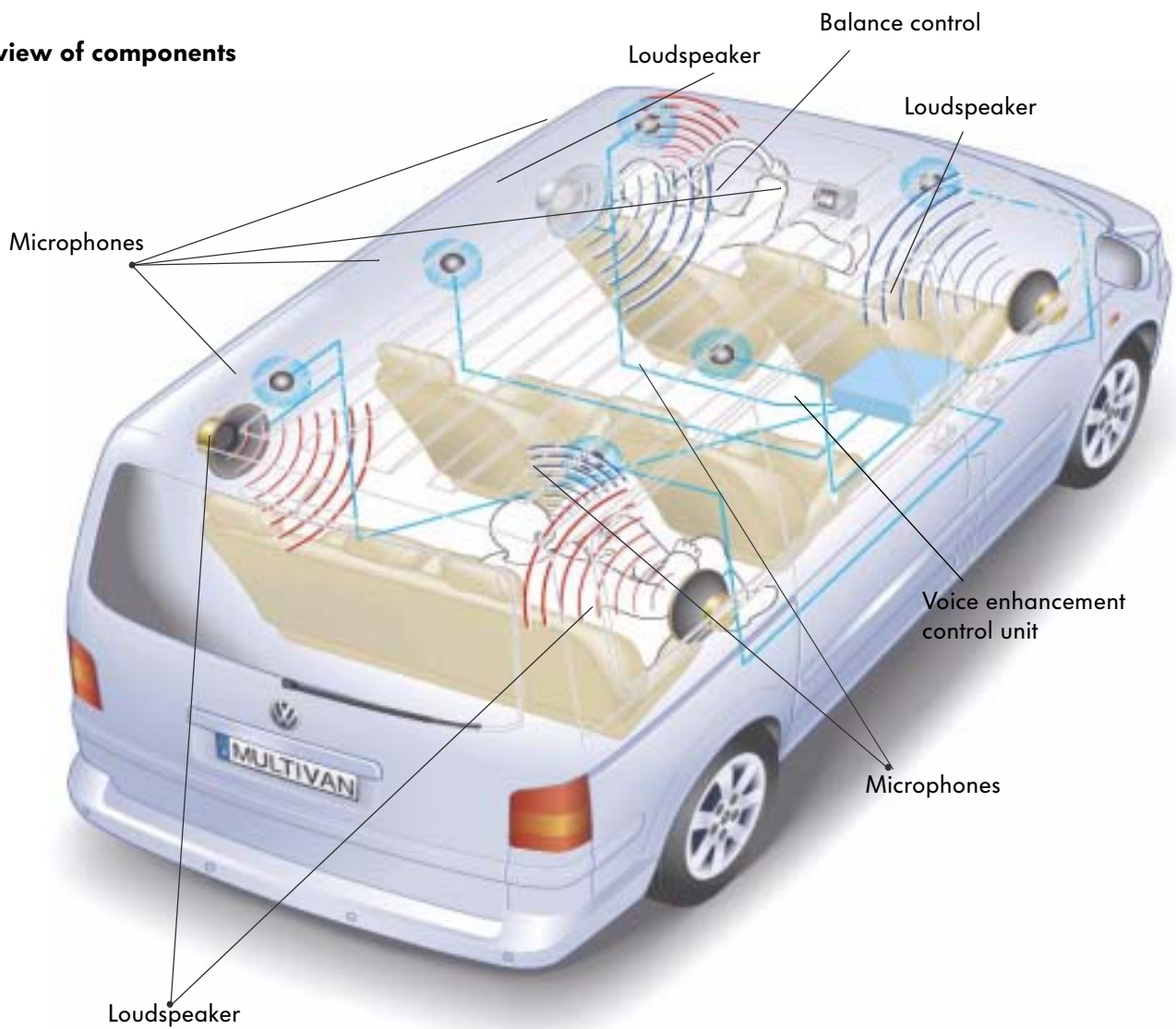

Radio/telephone/navigation

Digital Voice Enhancement active

Digital Voice Enhancement provides clear communications among the vehicle occupants and, if a telephone is fitted, as a hands-free talking facility for all vehicle occupants.

For this purpose, there are six microphones installed in the vehicle for picking up voice signals.

The voice of the loudest speaker is transmitted.

Voice is reproduced together with the radio signal or the navigation system voice output via the loudspeakers of the sound system.

The background driving noises picked up by the microphones are filtered out by the voice enhancement control unit.

The voice enhancement control unit is located in the signal path between the radio and the amplifier.

The mobile telephone operating electronics control unit is connected to the voice enhancement control unit.

During a telephone call, the signal from the currently active microphone is transmitted to the mobile telephone operating electronics control unit. Voice transmission within the vehicle remains active.

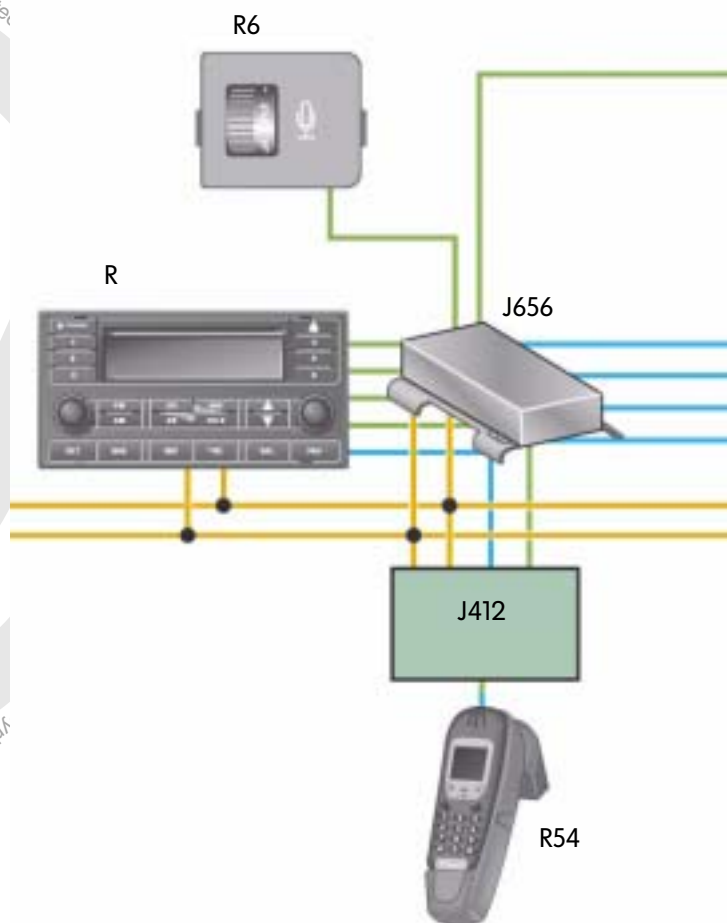

Legend

- J412 Mobile telephone operating electronics control unit
- J656 Voice enhancement control unit
- R Radio
- R2 Loudspeaker, front left
- R3 Loudspeaker, front right
- R4 Loudspeaker, rear left

Digital Voice Enhancement deactivated

When the Digital Voice Enhancement feature is deactivated, the radio signals are relayed in an unprocessed form to the 8-channel amplifier and played back through the loudspeakers. Voice signals are not transmitted.

During a telephone call, only the front left microphone (driver) is active. The telephone signals are also relayed in an unprocessed form.

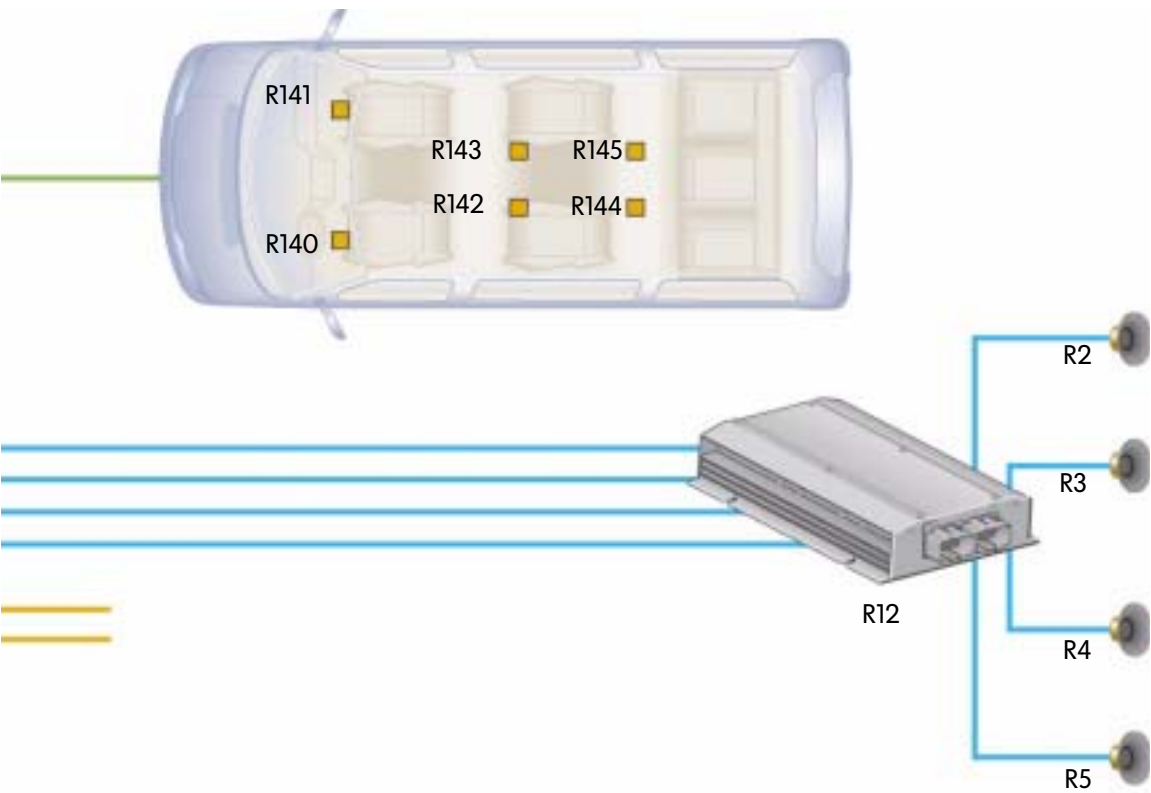

S311_094

- R5 Loudspeaker, rear right
- R6 Balance control
- R12 Amplifier
- R54 Mobile telephone
- R140 Front left microphone

- R141 Front right microphone
- R142 Centre left microphone
- R143 Centre right microphone
- R144 Rear left microphone
- R145 Rear right microphone

Radio/telephone/navigation

Amplifiers

External amplifier

It is possible to connect a loudspeaker system adapted to the vehicle interior by using external amplifiers. The loudspeaker system comprises tweeters, mid-range loudspeakers, bass reflex loudspeakers and a subwoofer.

The external amplifier generates signals with the corresponding frequency response for the individual loudspeakers.

Analogue 8-channel amplifier

The analogue 8-channel amplifier has a total of 10 outputs to which the five individual loudspeakers and four mid-range/treble loudspeakers are connected. One output remains unused.

For diagnostic purposes, the amplifier is connected to the convenience CAN data bus.

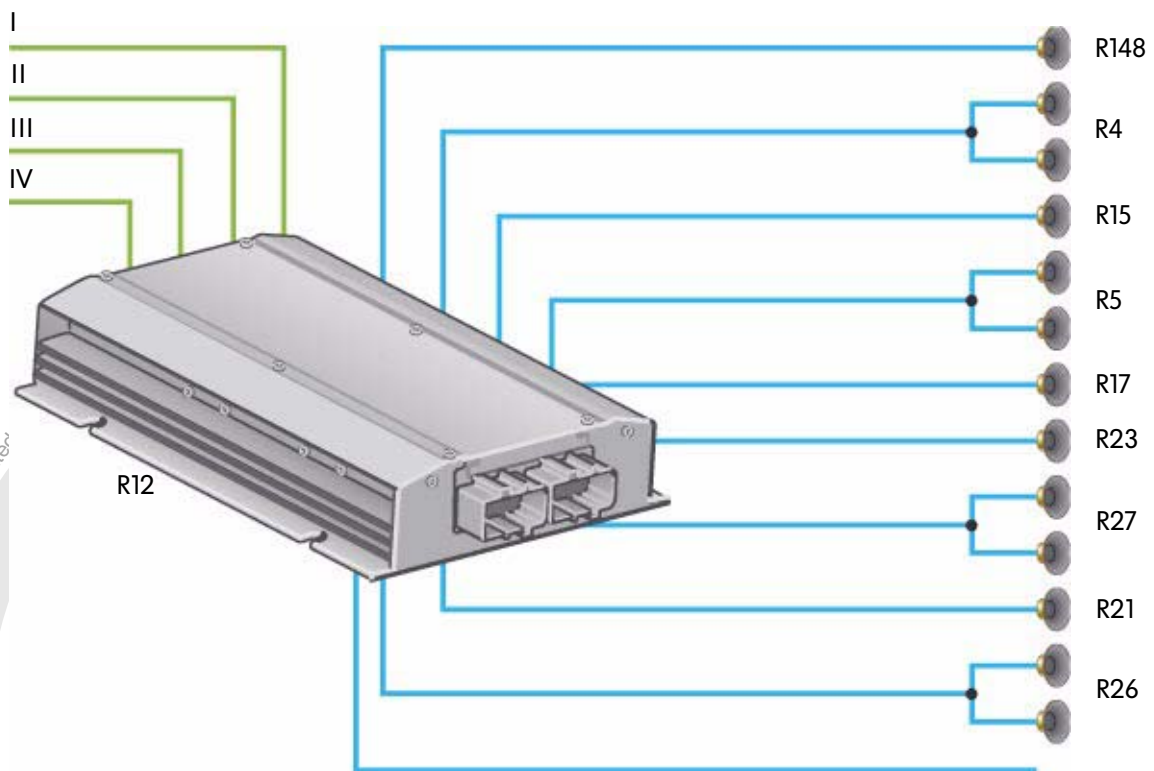

S311_098

Legend

| | | | |
|-----|------------------------------|--------|-------------------------------------------|
| R12 | Amplifier | R23 | Bass loudspeaker, front right |
| R4 | Loudspeaker, rear left | R26 | Mid-range/treble loudspeaker, front left |
| R5 | Loudspeaker, rear right | R27 | Mid-range/treble loudspeaker, front right |
| R15 | Bass loudspeaker, rear left | R148 | Subwoofer |
| R17 | Bass loudspeaker, rear right | I - IV | Radio input channels |
| R21 | Bass loudspeaker, front left | | |

Digital 12-channel amplifier

The digital 12-channel amplifier has a total of 12 outputs, to which are connected the five individual loudspeakers and four mid-range/treble loudspeakers. Three outputs remain unused.

To transfer the settings from the control panel and to the diagnostic system, the amplifier is connected to the convenience CAN data bus.

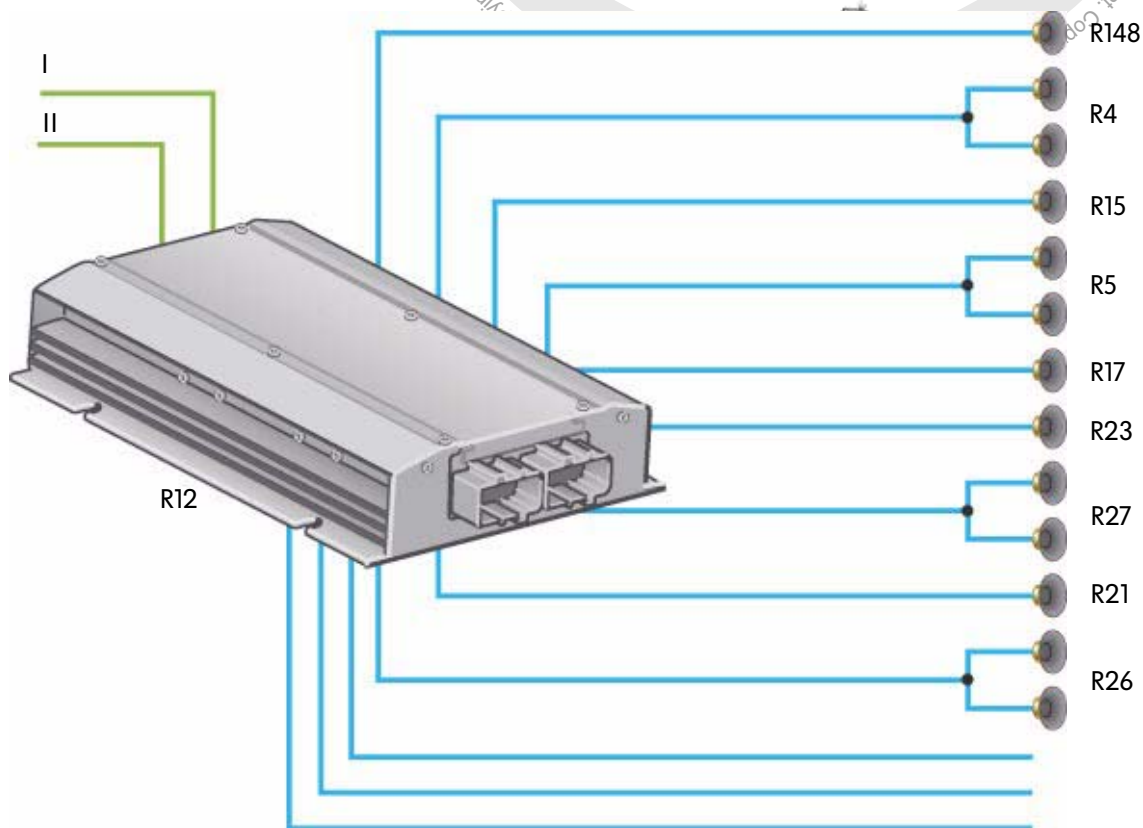

S311_099

Legend

| | | | |
|-----|------------------------------|--------|-------------------------------------------|
| R12 | Amplifier | R23 | Bass loudspeaker, front right |
| R4 | Loudspeaker, rear left | R26 | Mid-range/treble loudspeaker, front left |
| R5 | Loudspeaker, rear right | R27 | Mid-range/treble loudspeaker, front right |
| R15 | Bass loudspeaker, rear left | R148 | Subwoofer |
| R17 | Bass loudspeaker, rear right | I - II | Line-Out from radio |
| R21 | Bass loudspeaker, front left | | |

Radio/telephone/navigation

Aerial systems

Roof mounted aerial for GSM Dualband or GPS

This variant is fitted in

- Commercial vehicle
- Camper
- Multivan

in combination with GSM and/or GPS aerials

The dual-band GSM aerial is suitable for the digital radiotelephone network (D network) and the E network

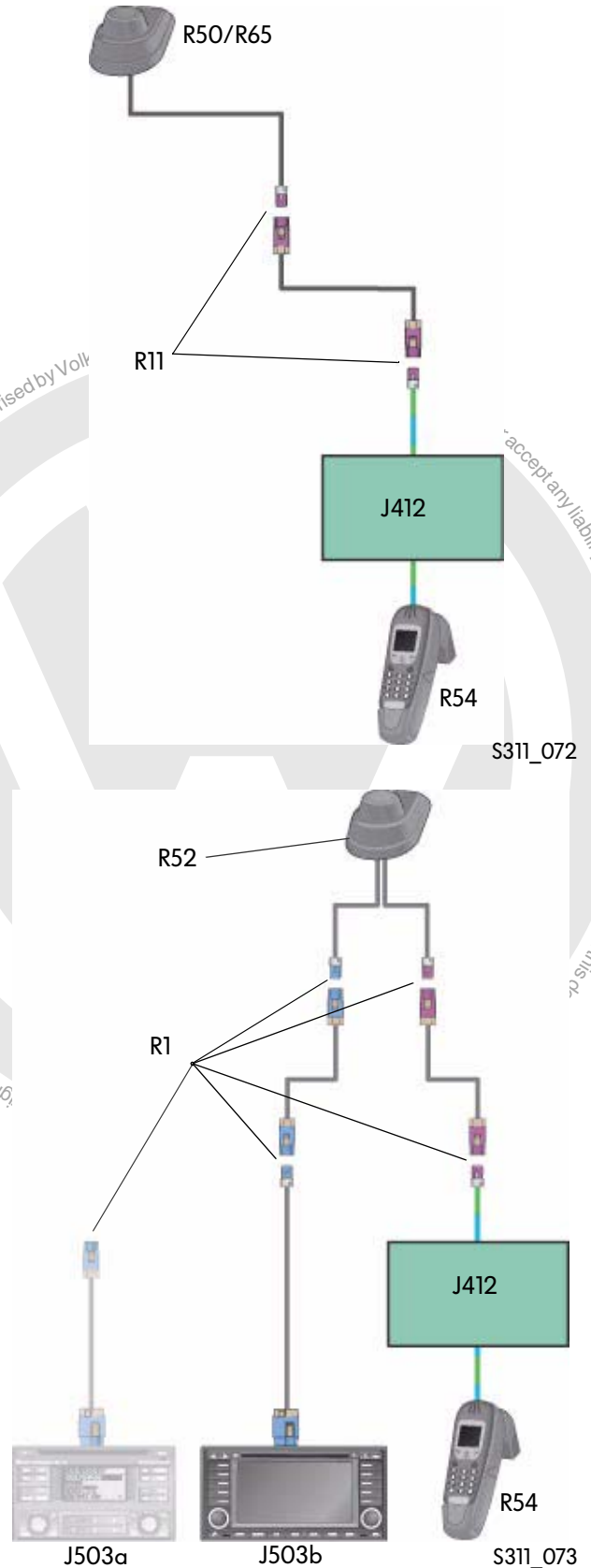

Roof mounted aerial for GPS and GSM Dualband

This variant is fitted in

- Commercial vehicle
- Camper
- Multivan

in combination with GSM and/or GPS aerials

Legend

- J412 Mobile telephone operating electronics control unit
- J503a Control unit with display for radio and navigation (Mono Chrome Display)
- J503b Control unit with display for radio and navigation (Multi Function Display)
- R1 Aerial connection (FAKRA connector)
- R50 Navigation aerial (GPS)
- R52 Radio/telephone/navigation aerial (GPS)
- R65 Telephone aerial

Windscreen aerial

This variant is fitted in

- Commercial vehicle
- Camper

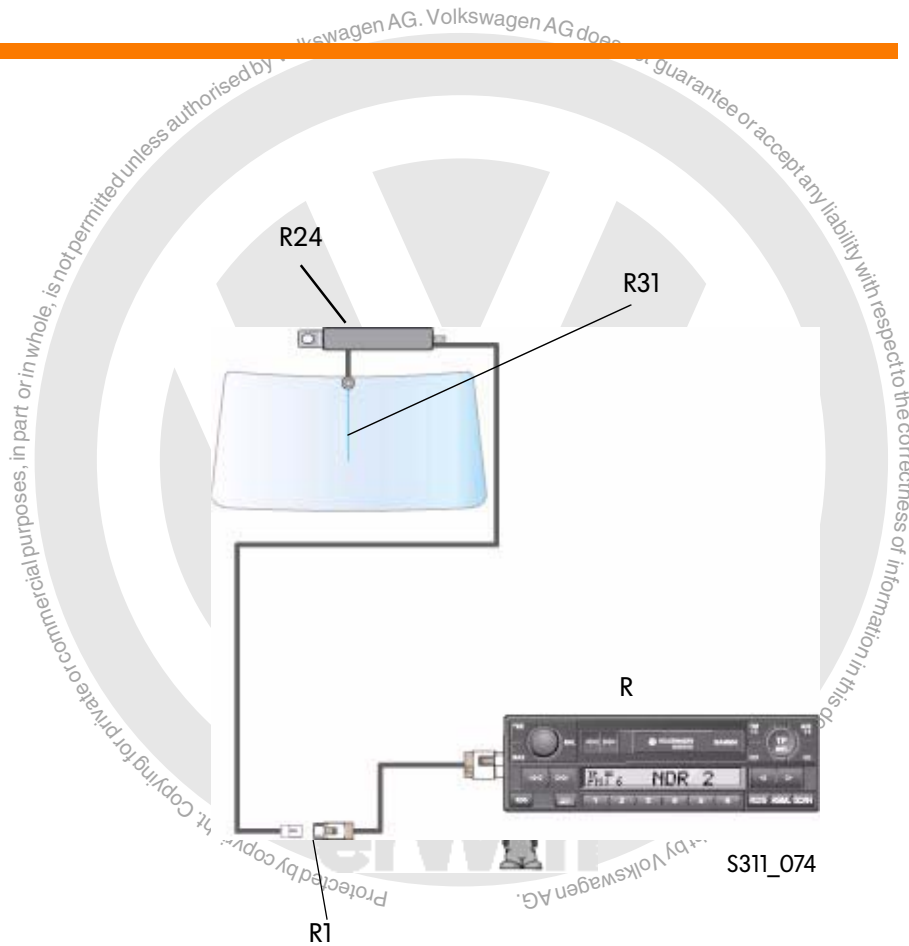

Side window aerial

This variant is fitted in

- Multivan right-hand drive vehicle
- European export left and right-hand drive vehicles equipped with a factory-fitted wiring harness for radio installation

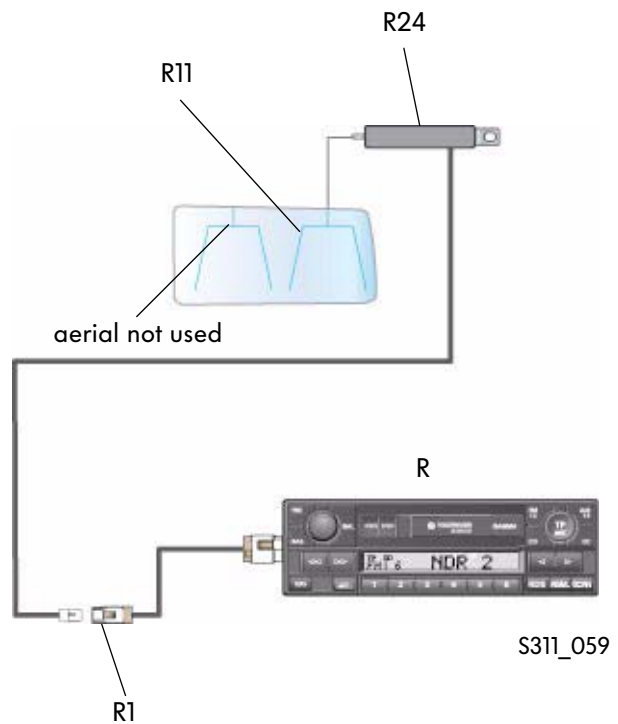

Legend

- R Radio
- R1 Aerial connection (FAKRA connector)
- R11 Aerial
- R24 Aerial amplifier
- R31 Window aerial

Radio/telephone/navigation

Diversity aerial

This variant is fitted in

- Multivan

Two aerials in the rear side windows.

The strongest of the four aerial signals is evaluated and utilised.

The voltage for the aerial selection control unit J515 is supplied via a separate cable.

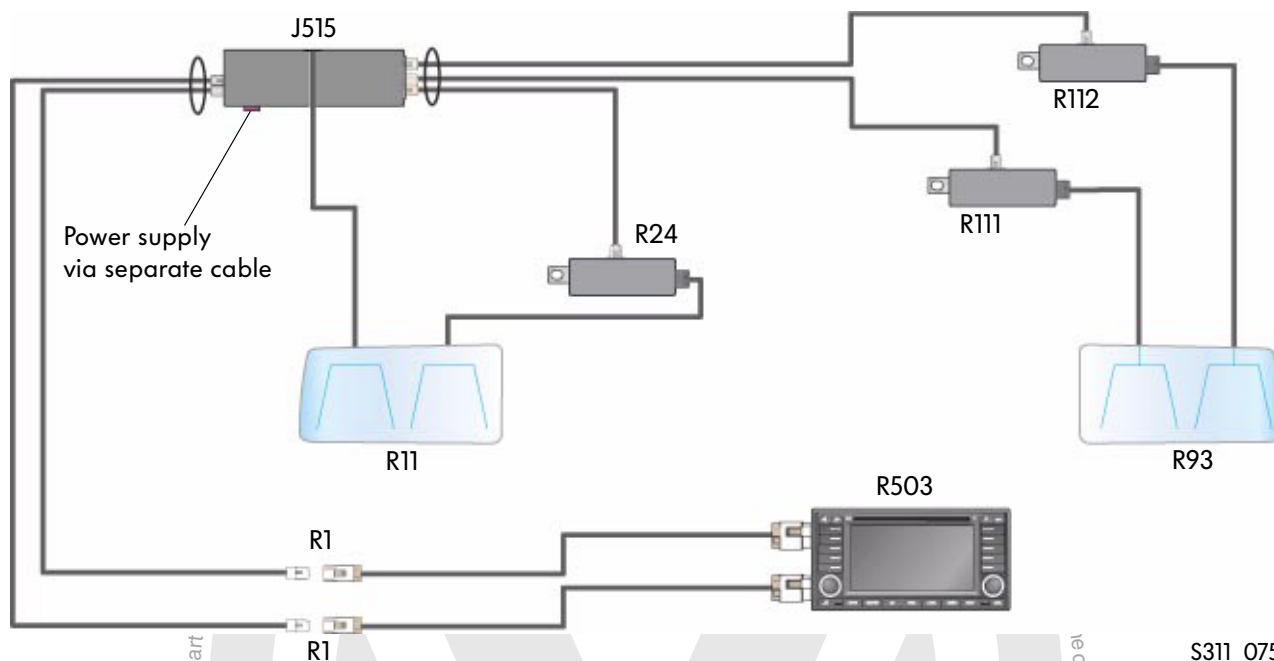

S311_075

Legend

- J503 Control unit with display for radio and navigation
- J515 Aerial selection control unit
- R1 Aerial connection (FAKRA connector)
- R11 Aerial

- R24 Aerial amplifier
- R93 Radio aerial 2
- R111 Aerial amplifier 2
- R112 Aerial amplifier 3

Aerial selection control unit J515

The reception signal of one of the four aerials is transmitted to the radio via the aerial selection control unit. The radio checks the quality of the signal and returns the result via the aerial wire. If the signal is too weak, the aerial selection control unit switches to the next aerial, whose signal is also checked in the radio. This process is continuously repeated, thus ensuring that the aerial with the best signal is always selected. The switchover operations are not noticeable to the user.

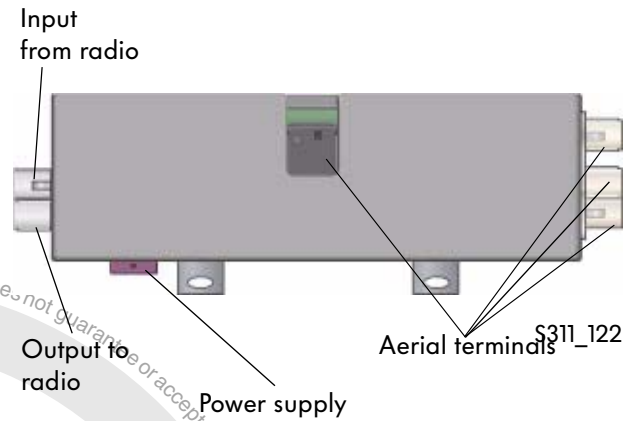

FAKRA connector

To prevent interchanging of the aerial terminals, the connectors are encoded. They also have different colours. Each connector plugs only into the associated mating socket.

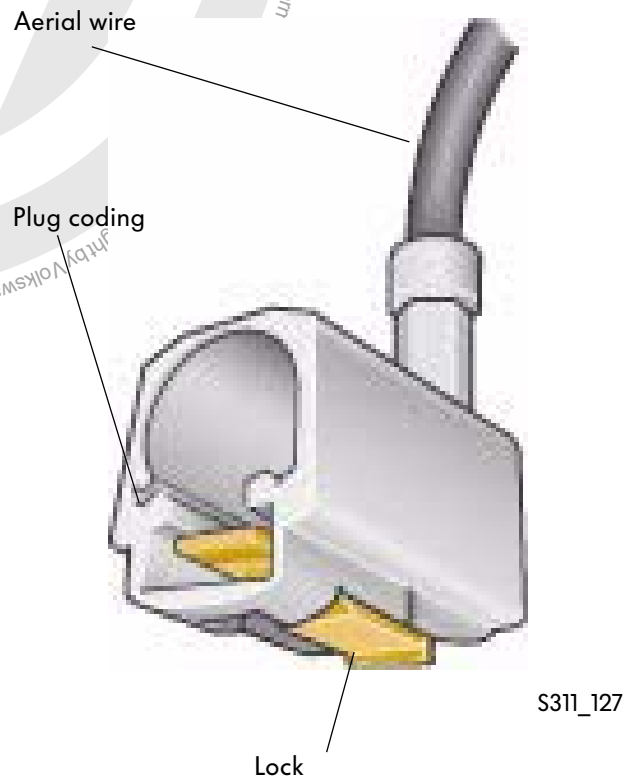

Air conditioning system

Air conditioning systems

The manual air conditioning system is available in two variants.

Manual air conditioning system for vehicles without R5 TDI engine

Manual air conditioning system with internally controlled compressor. The functions of the air conditioning system are monitored via the air conditioning system control unit J301, which is not provided with diagnostic capability and has no CAN data bus interface. The compressor is output-controlled. Compressor output is controlled via the regulating valve in the compressor and is dependent on the pressure differential of the refrigerant in the low and high pressure circuits

Manual air conditioning system for vehicles with R5 TDI engine

Manual air conditioning system with externally controlled compressor and air conditioning system compressor regulating valve N280. The functions are monitored and controlled via the air conditioner switch E30. The air conditioner switch is provided with diagnostic capability and has an interface to the convenience CAN data bus. The refrigerant temperature sender G454, the ambient temperature sensor G17 and the high pressure sender G65 enable cooling capacity to be set to a pre-determined setpoint.

The operator controls are identical in terms of their appearance and functions:

- AC function
- Air recirculation
- Temperature adjustment
- Air distribution
- Fresh air blower adjustment
- and - dependent on specification - activation of the second heat exchanger by the master switch (Multivan only)



S311_063

Climatronic

The Climatronic is operated via the air conditioning system/Climatronic operating and display unit E87 and the rear Climatronic operating and display unit E265.

The air conditioning system/Climatronic operating and display unit E87 and the Climatronic control unit J255 are combined as a modular unit.

The Climatronic control unit J255 controls all actuators.

The fresh air blower motor is activated by a pulse-width modulated signal via the fresh air blower control unit.



S311_062

Rear Climatronic operating and display unit

The rear Climatronic operating and display unit sends the signals to the rear actuators.

Both operating and display units (front and rear) exchange information via the convenience CAN data bus.



S311_101



The air conditioning system/Climatronic can be set to a lower power output or switched off, depending on engine load or of the electrical onboard power supply.

Diagnosis

The control units can be diagnosed with the Vehicle Diagnosis, Testing and Information System VAS 5051 or the Vehicle Diagnosis and Information System VAS 5052.

The connections to the individual control units are established in different ways.

Control unit with CAN data bus connection and virtual communication line to the data bus diagnostic interface

The connection is established via the communication line, the data bus diagnostic interface and the CAN data bus.

Control unit with communications cable connection

The connection is established via the communication line routed directly to the control unit.

Control unit with CAN data bus connection, without virtual communication line to the data bus diagnostic interface

The connection is established via a control unit with virtual communications line and the CAN data bus.

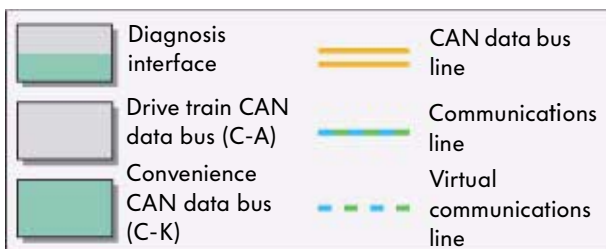

S311_037

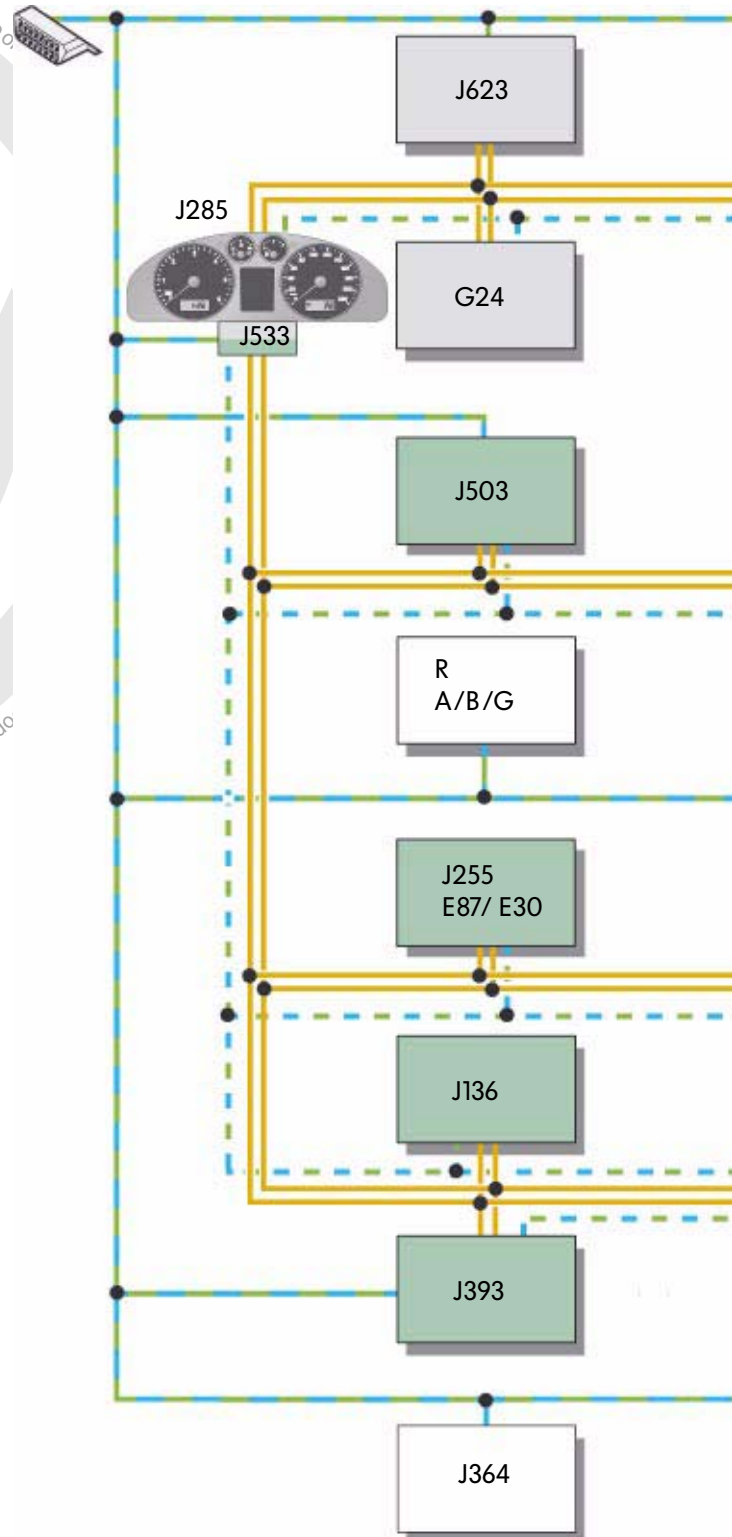

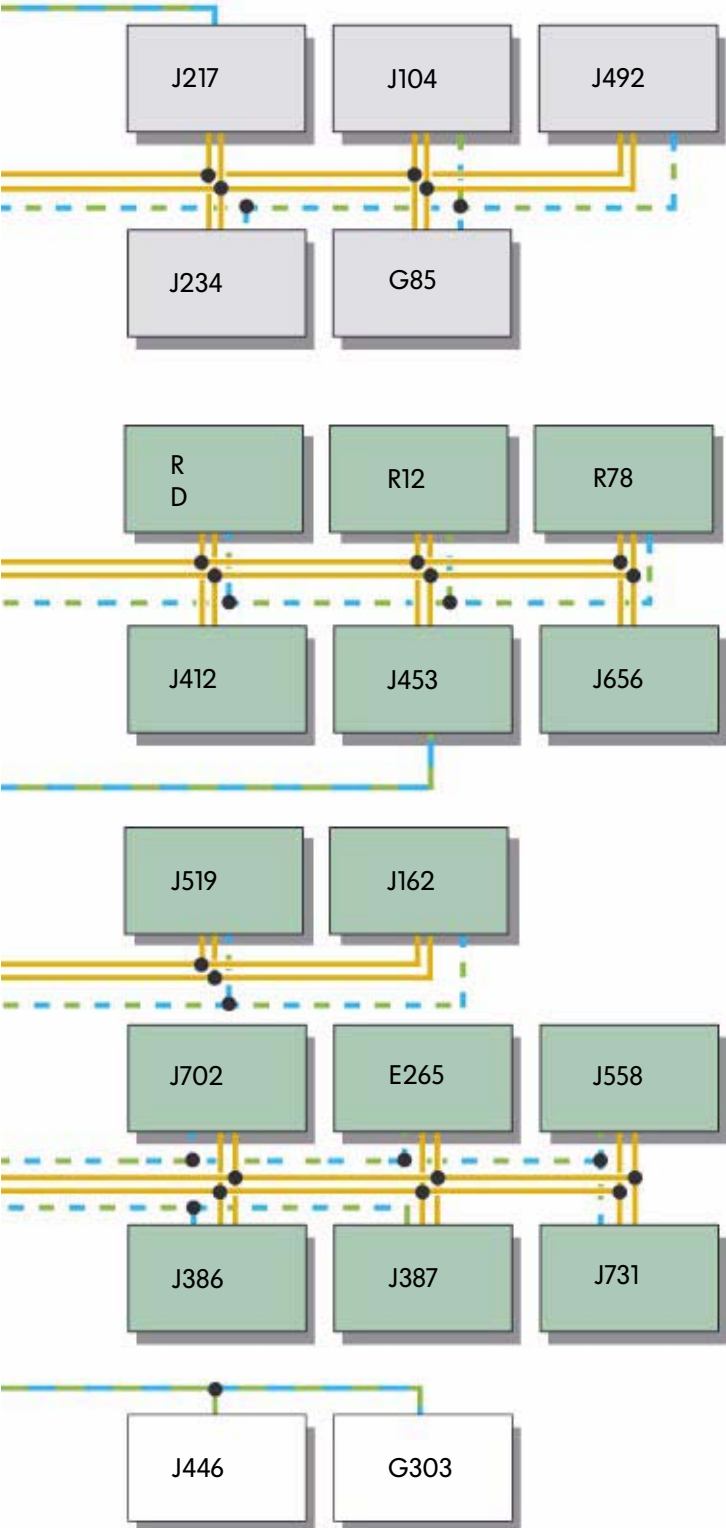

Legend

- G24 Tachograph
- E30 Air conditioner switch
- G85 Steering angle sender
- G303 Interior monitor sender/receiver module 1, master
- E87 Air conditioning system/Climatronic operating and display unit
- E265 Rear Climatronic operating and display unit
- J104 ABS with EDL control unit
- J136 Seat adjustment control unit with memory function
- J162 Heater control unit
- J217 Automatic gearbox control unit
- J234 Airbag control unit
- J255 Climatronic control unit
- J285 Control unit with display unit in dash panel insert
- J364 Additional heater control unit
- J386 Door control unit, driver side
- J387 Door control unit, front passenger side
- J393 Convenience system central control unit
- J412 Operating electronics control unit, mobile telephone
- J446 Parking aid control unit
- J453 Multi-function steering wheel control unit
- J492 Four-wheel drive control unit
- J503 Radio and navigation control unit with display unit
- J519 Onboard electrical system control unit
- J533 Data bus diagnosis interface
- J558 Sliding door control unit
- J623 Engine control unit
- J656 Voice enhancement control unit
- J702 Roof display unit
- J731 Right sliding door control unit
- R Radio:
 - A ALPHA
 - B BETA
 - G GAMMA
 - D DELTA
- R12 Amplifier
- R78 TV tuner

S311_112



Protected by copyright. Copyright by Volkswagen AG. Information in this document is for reference only.

Test yourself

1. Into what data bus systems is the network of the Volkswagen Transporter subdivided?

- œ a) The air conditioning system CAN data bus, the drive train CAN data bus and the convenience CAN data bus.
- œ b) The drive train CAN data bus and the convenience CAN data bus.
- œ c) The Infotainment CAN data bus and the diagnosis CAN data bus.

2. What is the task of the data bus diagnostic interface?

- œ a) It connects the drive train and convenience CAN data bus systems in such a way that both data bus systems can exchange data with each other.
- œ b) It transfers the data of the vehicle diagnosis, testing and information system VAS 5051 from the communications line to the CAN data bus for the diagnosis of control units which only have one virtual communications line.
- œ c) It performs the tasks of the immobilizer control unit J362 and transfers data from the Infotainment CAN data bus to the drive train CAN data bus.

3. What are the tasks of the onboard power supply control unit J519?

- œ a) It controls turn signal operation, and activates the interior lights, the reversing lights and the central locking.
- œ b) It controls turn signal operation, and activates the interior lights, the reversing lights and the power windows.
- œ c) It controls the turn signal operation, and activates the interior lights, the reversing lights and the electrical load management system.

4. The electrical load management system is allowed to take measures to maintain the onboard power supply

- œ a) when extreme short-distance operation is detected.
- œ b) when the engine is started.
- œ c) to avoid significant voltage drops due to high current consumers relevant to vehicle safety.

5. How is data transmitted to the electrical sliding door?

- œ a) Via a flexible cable connection and the T10 connector.
- œ b) Wirelessly via the sliding door reader coil and the sliding door magnetic coil.
- œ c) Via the sliding door CAN data bus.

6. Which of the following statements is true?

- œ a) Digital Voice Enhancement provides clear communications between the vehicle occupants and persons outside the vehicle.
- œ b) Digital Voice Enhancement provides clear communications between the vehicle occupants and other telephone callers.
- œ c) Digital Voice Enhancement is only active when the telephone is switched off.





For internal use only © VOLKSWAGEN AG, Wolfsburg

All rights and the right to make technical alterations reserved

000.2811.32.20 Technical status 03/03

 This paper was manufactured from pulp that
was bleached without the use of chlorine.