

**Service Training**

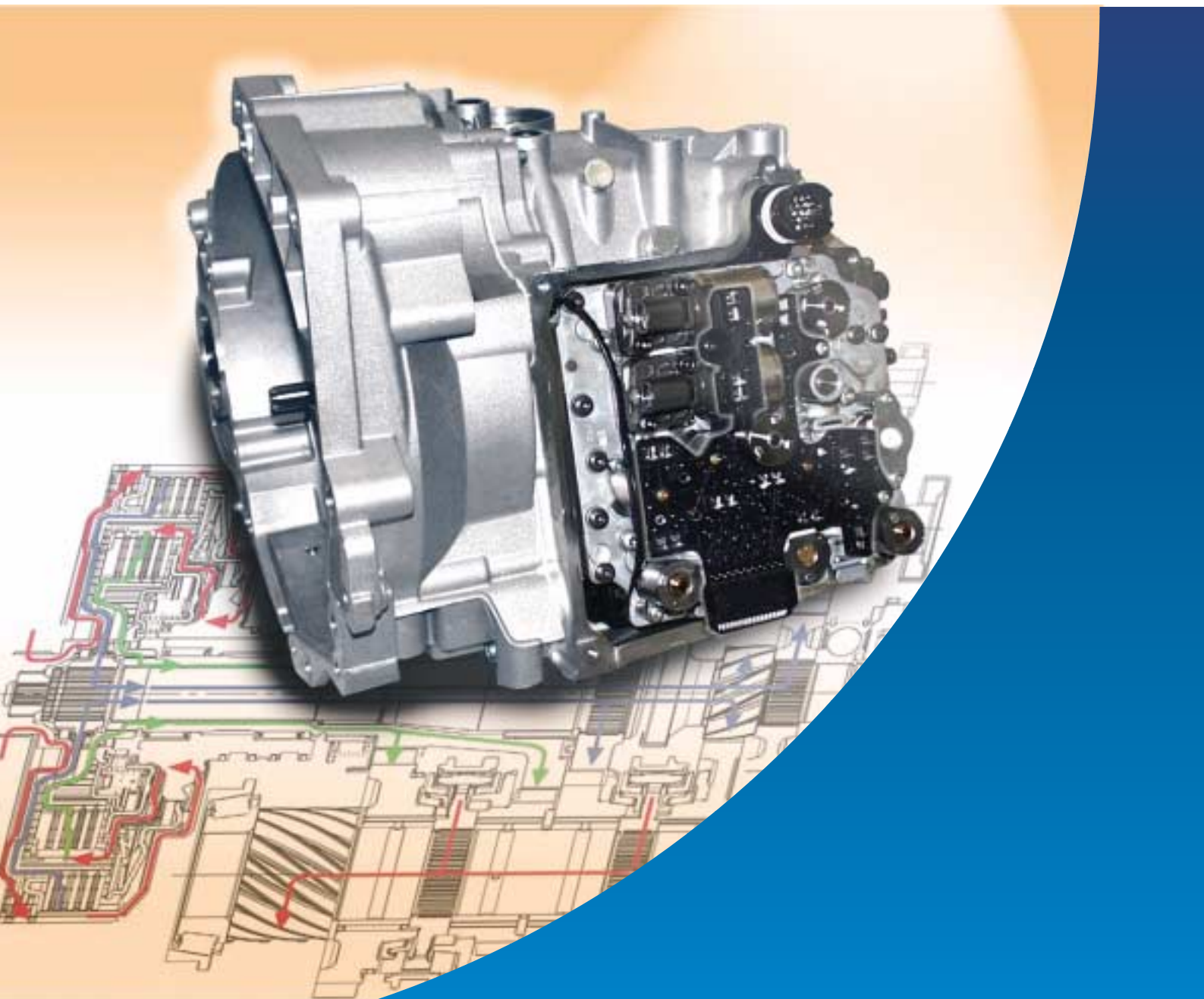

**Self-study programme 308**

**Direct Shift Gearbox 02E**



This self-study programme is designed to help you understand the **Direct Shift Gearbox**.

There is also a multimedia CD available on the direct shift gearbox.

This CD allows you to see how individual components work and how they combine with other components for operation of the gearbox.

From interactive menus, the subjects

- Selector lever
- Gearbox construction
- Oil lubrication circuit
- Selection actuators

can be chosen.



**NEW**



**Important  
Note**

**This self-study programme shows the design and function of new developments!  
The contents will not be updated.**

For the latest testing, adjustment and repair instructions, please refer to the relevant service literature.

# Contents



<b>Introduction</b> .....	<b>4</b>
<b>Selector lever</b> .....	<b>6</b>
<b>Construction of DSG</b> .....	<b>12</b>
Basic principle .....	12
Torque input .....	13
Multi-plate clutches .....	14
Input shafts .....	16
Output shafts .....	18
Reverse shaft .....	20
Differential .....	21
Parking lock .....	22
Synchronisation .....	23
Torque transmission in vehicle .....	24
Transmission route through gears .....	25
<b>Mechatronics module</b> .....	<b>28</b>
<b>Electro-hydraulic control unit</b> .....	<b>30</b>
<b>Oil lubrication circuit</b> .....	<b>32</b>
<b>System overview</b> .....	<b>40</b>
<b>Sensors/actuators</b> .....	<b>42/50</b>
<b>Functional diagram</b> .....	<b>56</b>
<b>CAN data bus connection</b> .....	<b>58</b>
<b>Diagnosis</b> .....	<b>59</b>
<b>Service</b> .....	<b>60</b>
<b>Test yourself</b> .....	<b>61</b>



# Introduction



Currently, the world of transmission is dominated in Europe by manual gearboxes and in the USA and Japan by automatic gearboxes. Both types of gearboxes have specific advantages and disadvantages.

The advantages of a manual gearbox are, for example,

- high degree of efficiency
- robust and sporty characteristic.

The advantages of an automatic gearbox are, for example,

- a high level of comfort, above all in gear changes, as there is no interruption in tractive power.

This formed the framework for Volkswagen to combine both transmission concepts into one completely new gearbox generation: the direct shift gearbox.

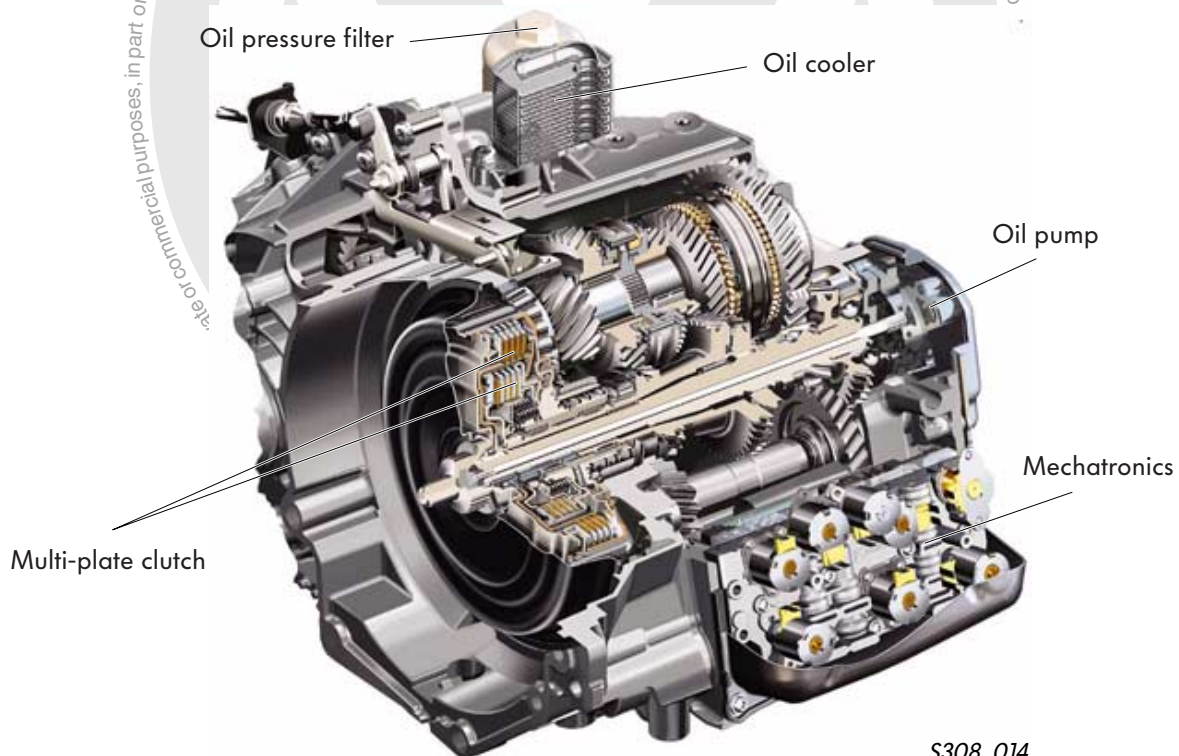

Thanks to the double multi-plate clutch design and different automatic gear selection programmes, it is well capable of meeting the high demands in comfort from drivers who favour automatic gearboxes.

Furthermore, with direct selection and lightning fast, jolt-free gear changes, it also offers a high level of driving enjoyment to drivers who favour manual gearboxes.

In both cases, fuel consumption is at a par with economical vehicles fitted with manual gearboxes.



The direct shift gearbox is distinguished by

- Six forward gears and one reverse gear
- Normal driving program "D", sports program "S" as well as Tiptronic selector lever and Tiptronic steering wheel levers (optional)
- Mechatronics, electronic and electro-hydraulic control unit form one unit and are housed in the gearbox
- Hillholder function – if the vehicle begins to move when stationary, with just light brake application, the clutch pressure is increased and the vehicle is held in position
- Creep regulation – allows creeping of the vehicle, when parking for example, without accelerator pedal application
- Emergency mode

In the event of a fault, the vehicle can still be driven, with emergency mode activated, in 1st and 3rd gear or just in 2nd gear.

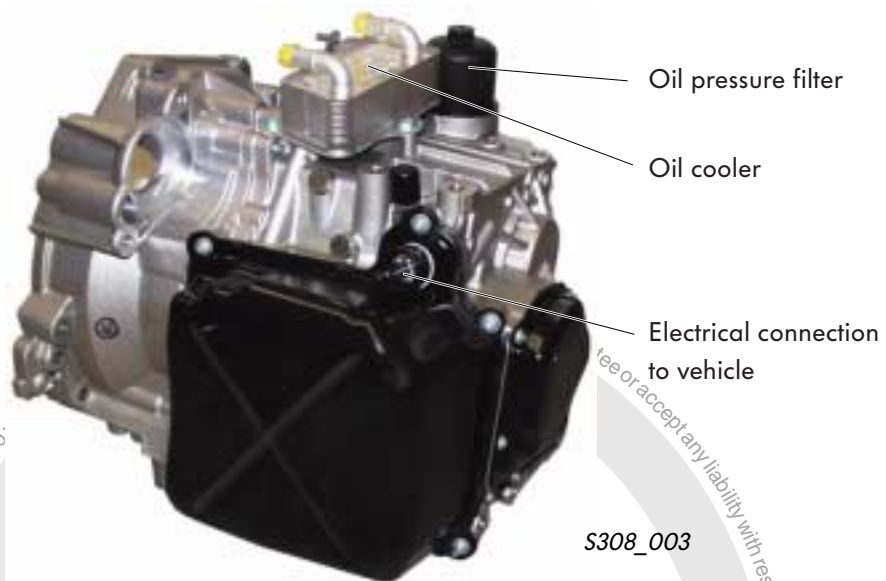

#### Technical data

Designation	DSG 02E (direct shift gearbox)
Weight	Approx. 94 kg front-wheel drive, 109 kg 4motion
Torque	Maximum 350 Nm (depending on engine)
Clutch	Two multi-layer wet plate clutches
Gear stages	Six forward, one reverse gear (all synchronised)
Operating mode	Automatic and Tiptronic
Oil volume	7.2 ltr. DSG oil G052 182

The direct shift gearbox is already available for Golf R32 and Touran models. Future plans are to make it available for the New Beetle and Golf 2004.



# Selector lever

## Operation

The selector lever is actuated in the vehicle in the same way as an automatic gearbox. The direct shift gearbox also offers the option of Tiptronic gear selection.

As in vehicles with automatic gearboxes, the selector lever features lever locks and an ignition key lock. The function of the locks remains unchanged. The design, however, is new.

The gear selector lever positions are:

### **P - Park**

To move the selector lever out of this position, the ignition must be "on" and the brakes applied. Furthermore, the release button on the selector lever must be pressed.

### **R - Reverse gear**

To engage reverse gear, the release button must be pressed.

### **N - Neutral position**

In this position, the gearbox is at idle. If, for a length of time, the gear selector lever is left in this position, the brake pedal must be pressed for it to be moved.

### **D - Drive**

In this position, the forward gears are selected automatically.

### **S - Sport**

Gears are selected automatically using a "sporty" program stored in the control unit.

### **+ and -**

The Tiptronic functions can be used with the selector lever in the right gate and with the steering wheel gear selectors.

Release button



S308\_004

Steering wheel gear selectors



S308\_063

## Design of selector lever

### Selector lever sensors control unit J587

Hall sensors in the gear selector lever mounting detect the position of the selector lever and make the positions available to the mechatronics via the CAN bus .

### Selector lever lock solenoid N110

Solenoids hold the selector lever in positions "P" and "N". The solenoid is activated by the selector lever sensor control unit J587.

### Selector lever locked in position "P" switch F319

If the selector lever is in the "P" position, selector lever locked in position "P" switch sends a signal to the steering column electronics control unit J527.

The control unit requires this signal for actuation of the ignition key withdrawal lock.

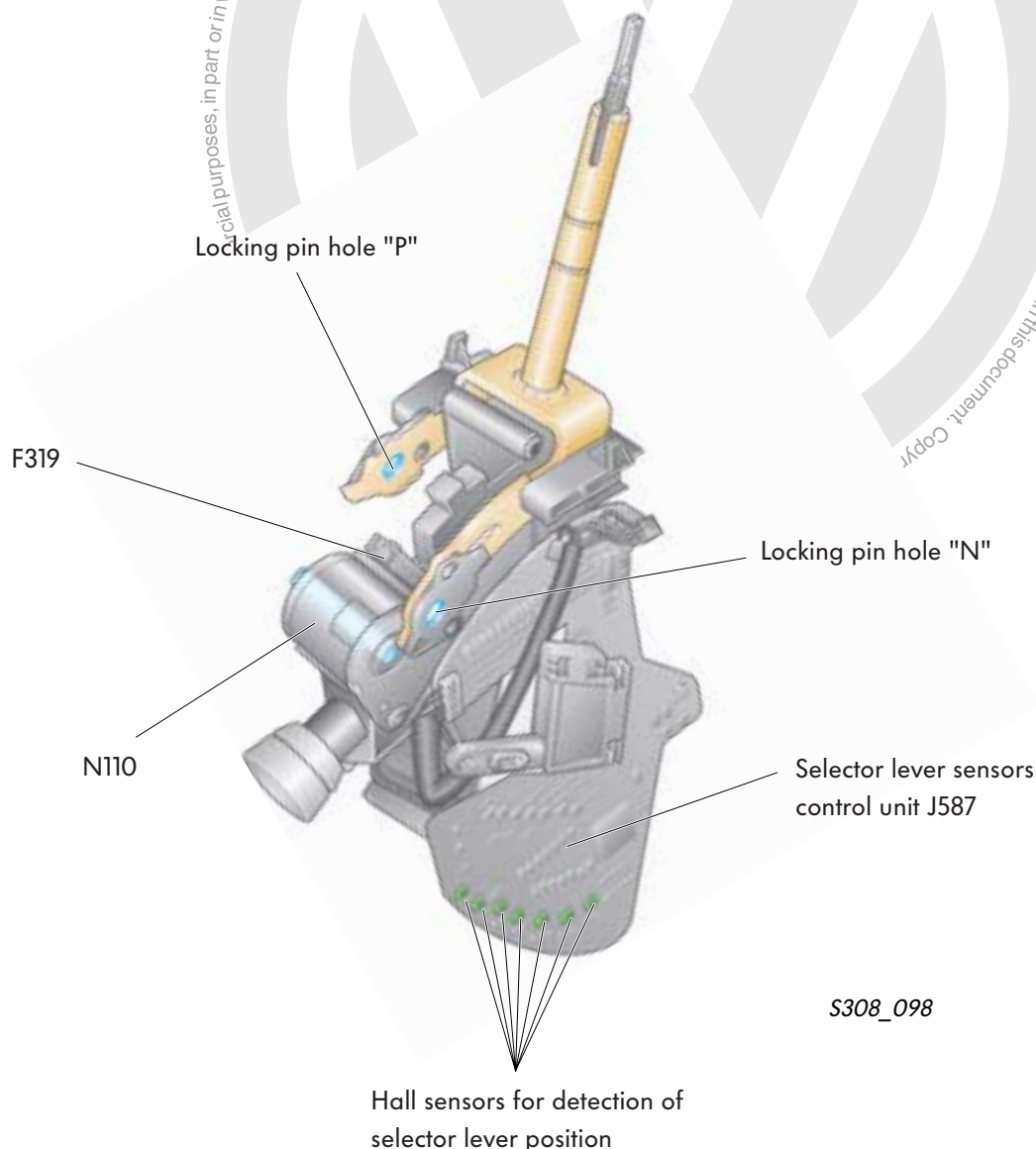

S308\_098

# Selector lever

## Selector lever lock solenoid N110

This is how it works:

### Selector lever locked in "P":

When the selector lever is in the "P" position, the locking pin is in the locking pin hole for "P". This way, the selector lever is stopped from being moved inadvertently out of position.

Selector lever lock solenoid N110

Spring

Locking pin hole for "P"

Locking pin

S308\_103

### Selector lever released:

When the ignition is switched on and the brake pedal is pressed, the selector lever sensors control unit J587 energises the solenoid N110. In this way, the locking pin is pulled out of the locking pin hole "P".

The selector lever can now be moved into the drive position.



S308\_101

### Selector lever locked in "N":

If the selector lever is in the "N" position for longer than 2 seconds, the control unit will energise the solenoid. In this way, the locking pin is pushed into the locking pin hole "N". The selector lever can no longer be moved inadvertently into a drive position. The locking pin is released when the brake pedal is pressed.

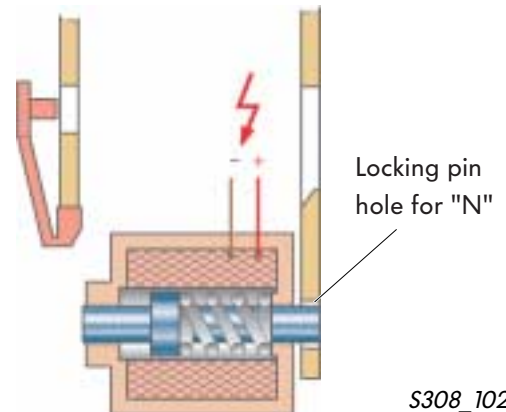

S308\_102

## Emergency release

If the power supply fails to the selector lever lock solenoid N110, the selector lever can no longer be moved because selector lever lock "P" remains activated in the event of power failure.

By pressing in the locking pin mechanically using a thin object, the lock can be released and the selector lever can be moved out of the "N" position for emergency purposes.

The vehicle can then be driven again.

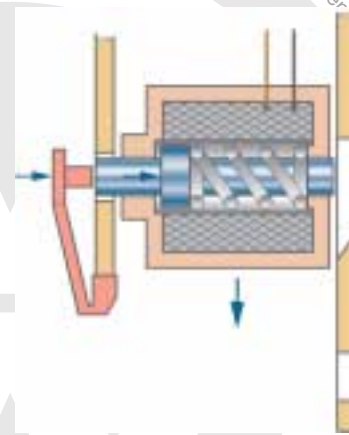

S308\_104



# Selector lever

## Ignition key withdrawal lock

The ignition key withdrawal lock prevents the ignition key from being turned to the withdrawal position unless the parking lock is engaged.

It works on an electro-mechanical principle and is actuated by the steering column electronics control unit J527.

The steering column electronics control unit J527 detects the open switch. The ignition key withdrawal lock solenoid N376 is not supplied with power. The spring in the solenoid pushes the locking pin to the release position.

### This is how it works:

Selector lever in "park position", ignition switched off.

When the selector lever is in the park position, the "selector lever locked in position P" F319 is open.



S308\_093

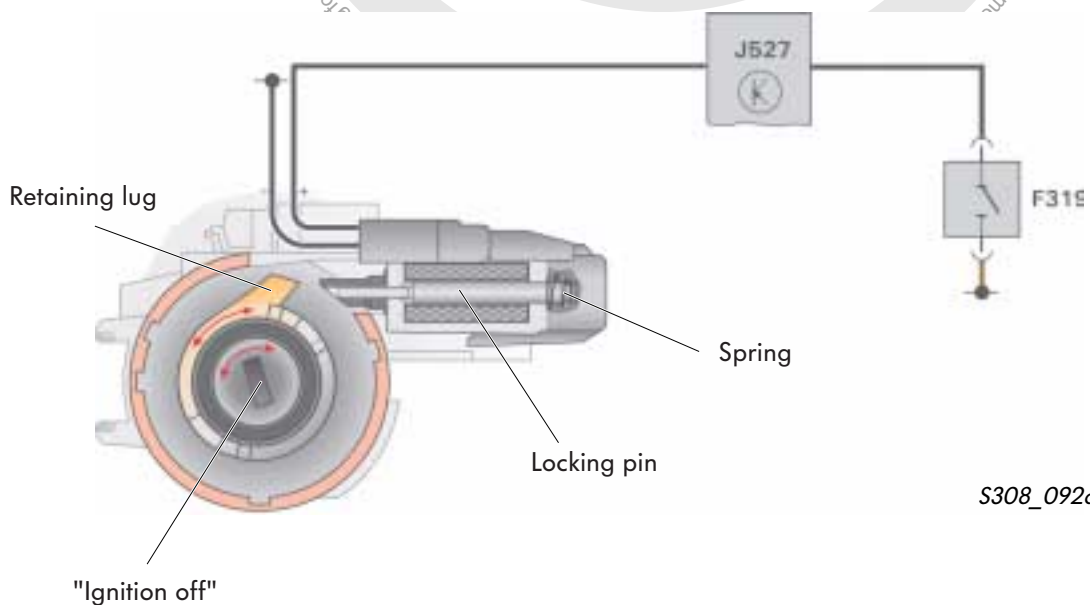

S308\_092a

**This is how it works:**

"Selector lever in drive position", ignition on.

In the drive position, the "selector lever locked in position P" switch F319 is closed.

The steering column electronics control unit then energises the ignition key withdrawal lock solenoid N376.

The locking pin is pushed into the lock position against spring pressure by the solenoid.

In the lock position, the locking pin prevents the ignition key from being turned back and withdrawn.

Not until the selector lever is placed in the park position is the "selector lever locked in position P" switch opened. The control unit then isolates the power supply to the solenoid.

The locking pin is then pushed back by the spring. The ignition key can be turned further and withdrawn.

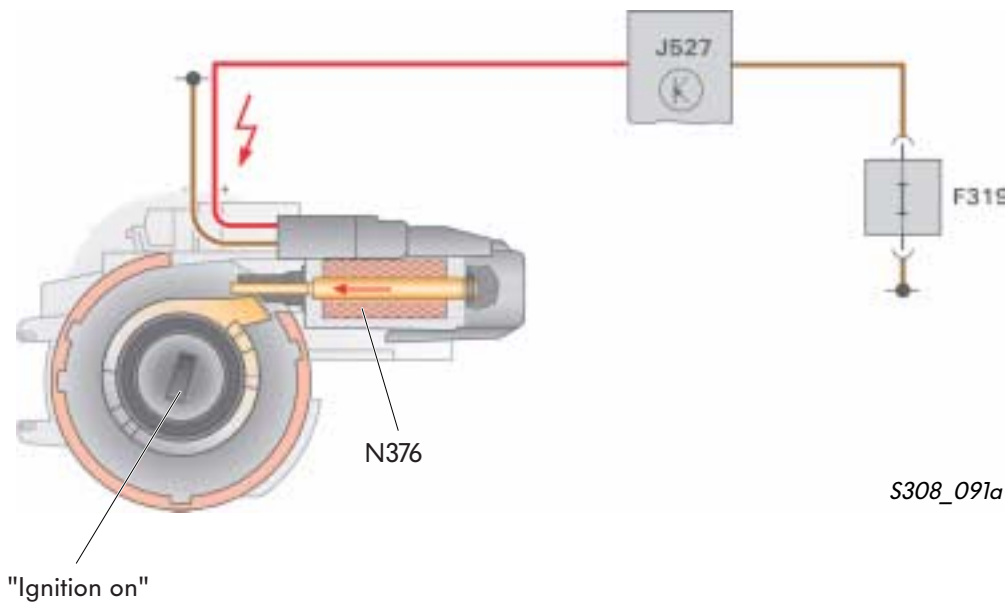

S308\_091a



# Construction of DSG

## Basic principle

The direct shift gearbox comprises in essence of two transmission units that are independent of each other.

Each transmission unit is constructed in the same way as a manual gearbox. Allocated to each transmission unit is a multi-plate clutch.

Both multi-plate clutches are of the wet type and work in DSG oil. They are regulated, opened and closed by the mechatronics system, depending on the gear to be selected.

1st, 3rd, 5th and reverse gear are selected via multi-plate clutch K1.

2nd, 4th and 6th gear are selected via multi-plate clutch K2.

One transmission unit is always in gear and the other transmission unit has the next gear selected in preparation but with the clutch still in the open position.

Every gear is allocated a conventional manual gearbox synchronisation and selector element.

Diagram showing principle of operation

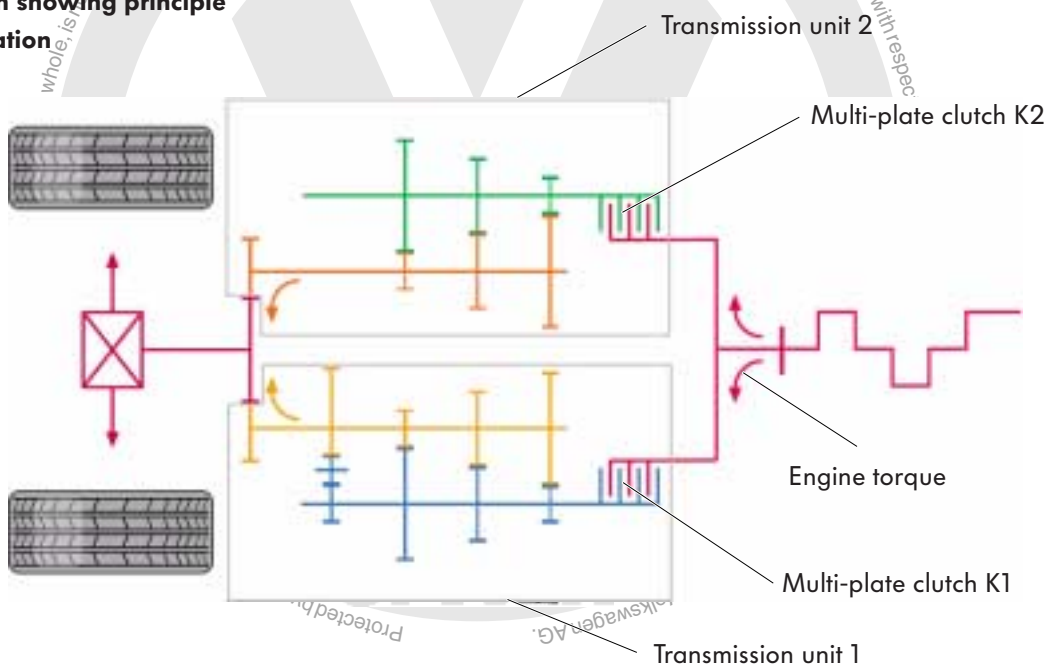

S308\_013

## Torque input

The torque is transmitted from the crankshaft to the dual mass flywheel.  
The splines of the dual mass flywheel on the input hub of the double clutch transmit the torque to the drive plate of the multi-plate clutch.

This is joined to the outer plate carrier of clutch K1 with the main hub of the multi-plate clutch.  
The outer plate carrier of clutch K2 is also positively joined to the main hub.

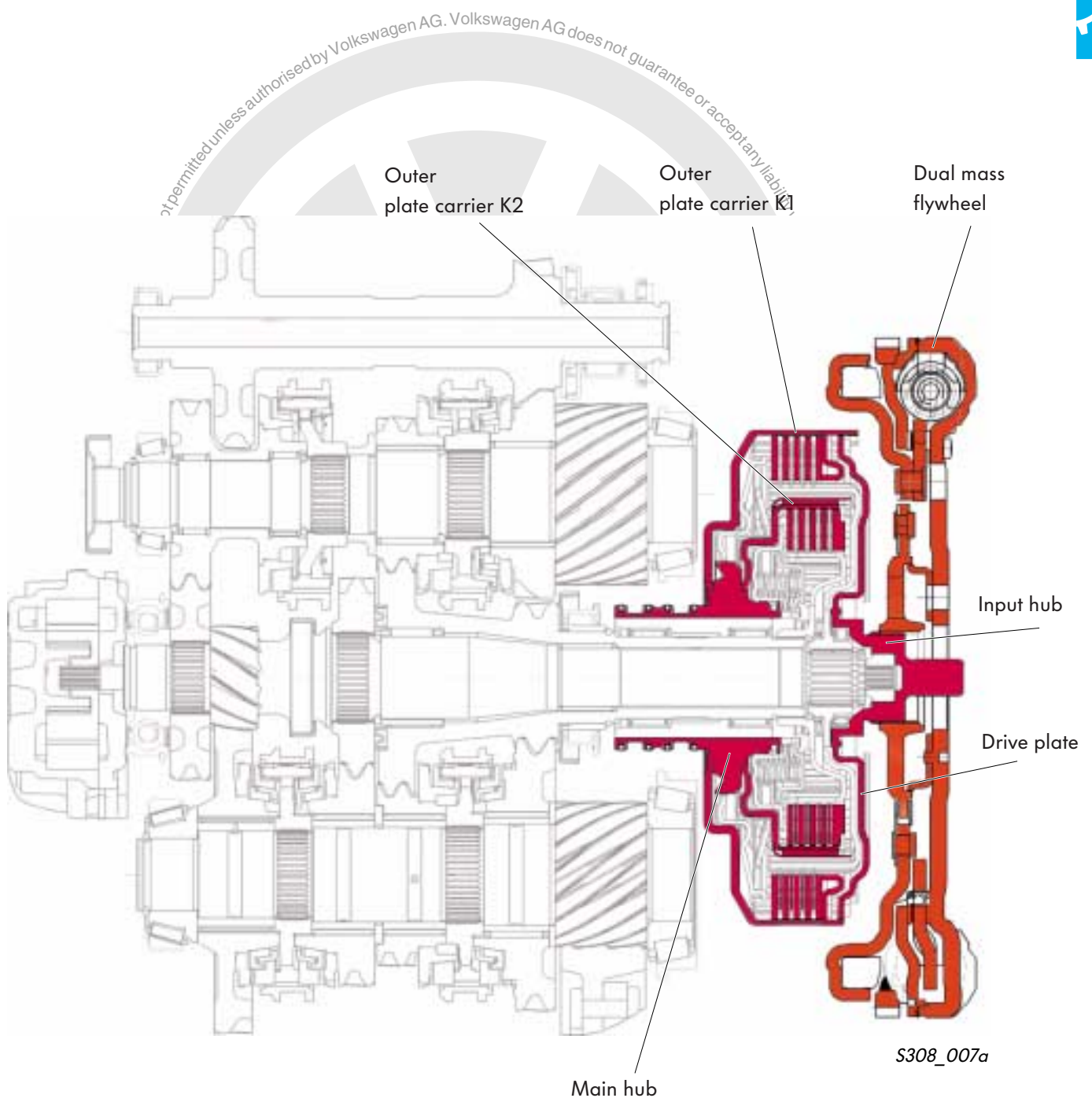

# Construction of DSG

## Multi-plate clutches

The torque is transmitted to the relevant clutch through the outer plate carrier. When the clutch closes, the torque is transmitted further to the inner plate carrier and then to the relevant input shaft. One multi-plate clutch is always engaged.

### Multi-plate clutch K1

Clutch K1 is of the multi-plate type. It is the outer clutch and transmits torque to input shaft 1 for 1st, 3rd, 5th and reverse gear. To close the clutch, oil is forced into the oil pressure chamber of clutch K1.

In this way, plunger 1 is pushed along its axis and the plates of clutch K1 are pressed together. Torque is transmitted via the plates of the inner plate carrier to input shaft 1. When the clutch opens, a diaphragm spring pushes plunger 1 back to its start position.

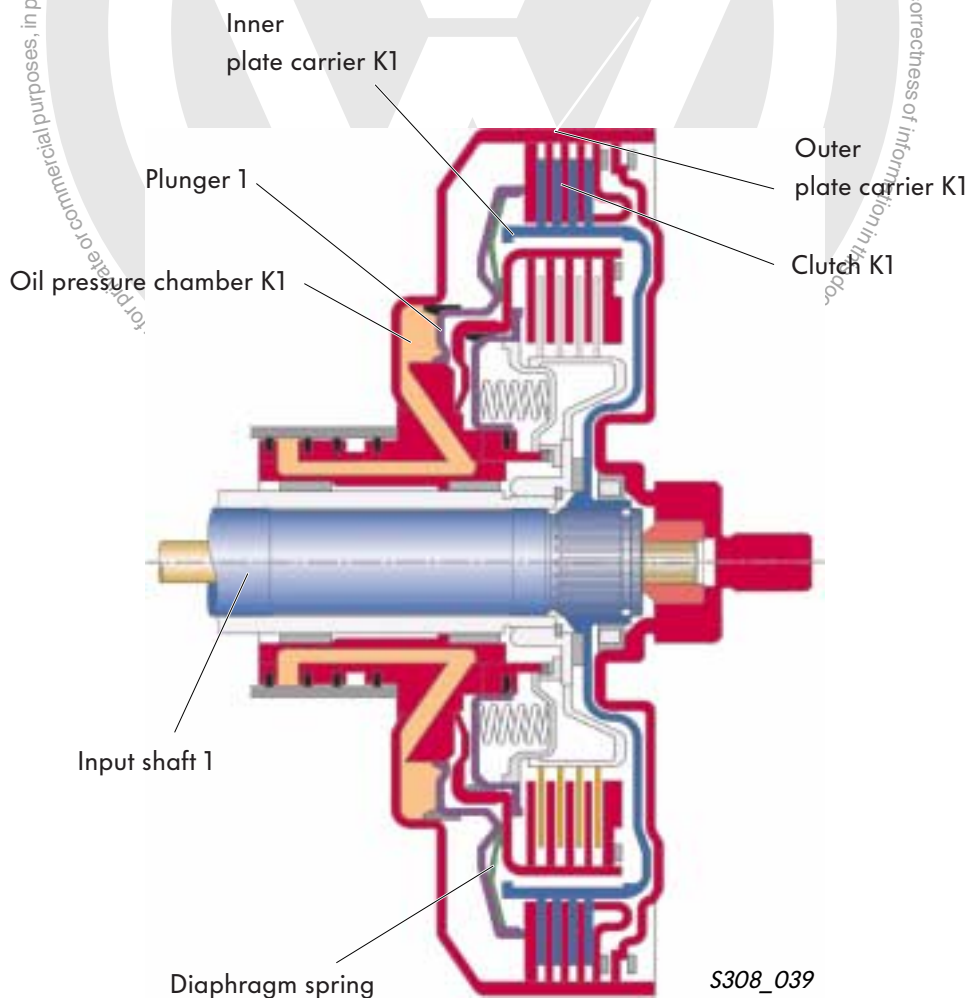

S308\_039

## Multi-plate clutch K2

Clutch K2 is of the multi-plate type. It is the inner clutch and transmits torque to input shaft 2 for 2nd, 4th and 6th gear.

To close the clutch, oil is forced into the oil pressure chamber of clutch K2. Plunger 2 then joins the drive via the plates to input shaft 2.

The coil springs press plunger 2 back to its start position when the clutch is opened.

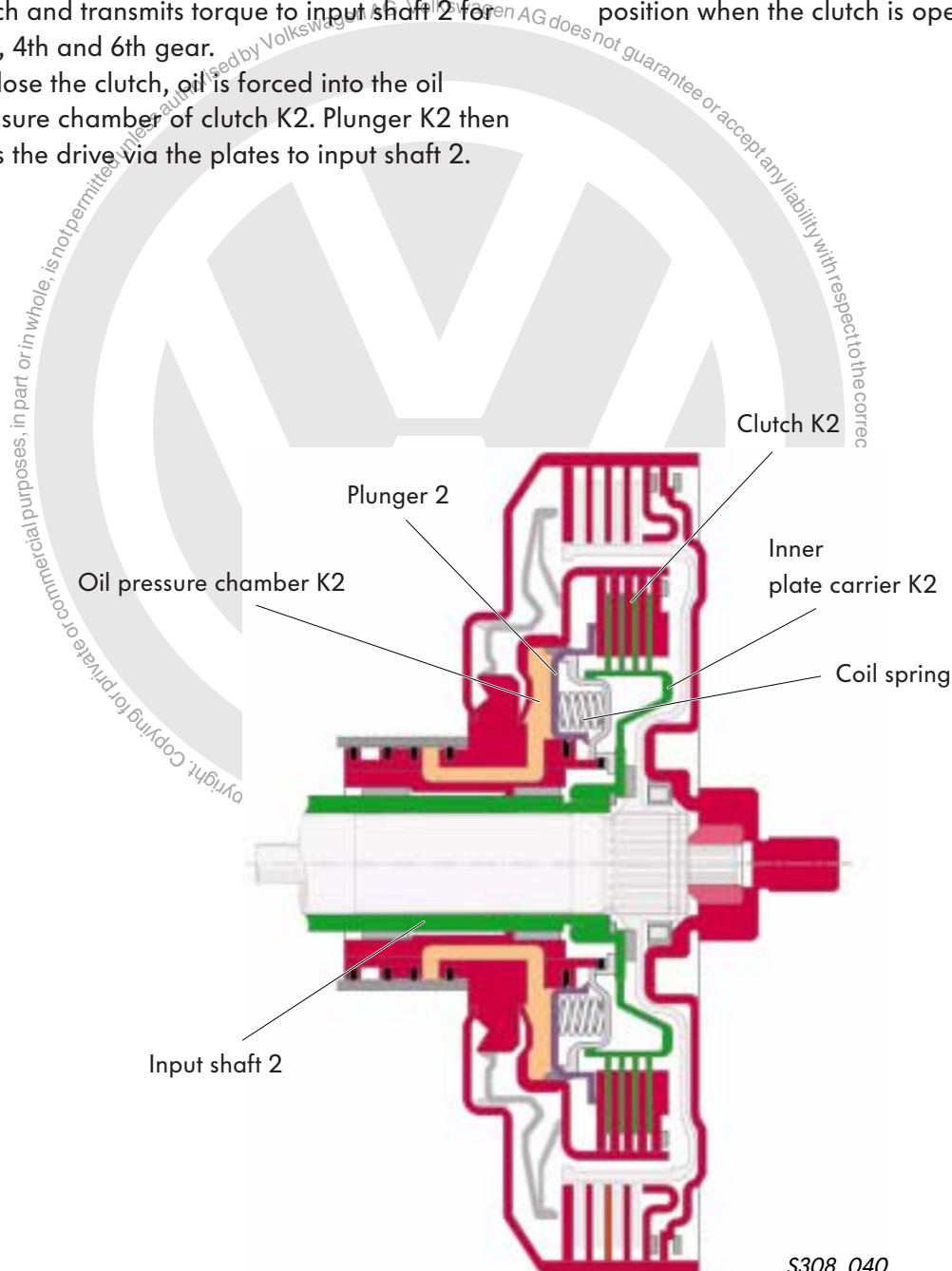

S308\_040



# Construction of DSG

## Input shafts

The engine torque is transmitted to the input shafts from multi-plate clutches K1 and K2.

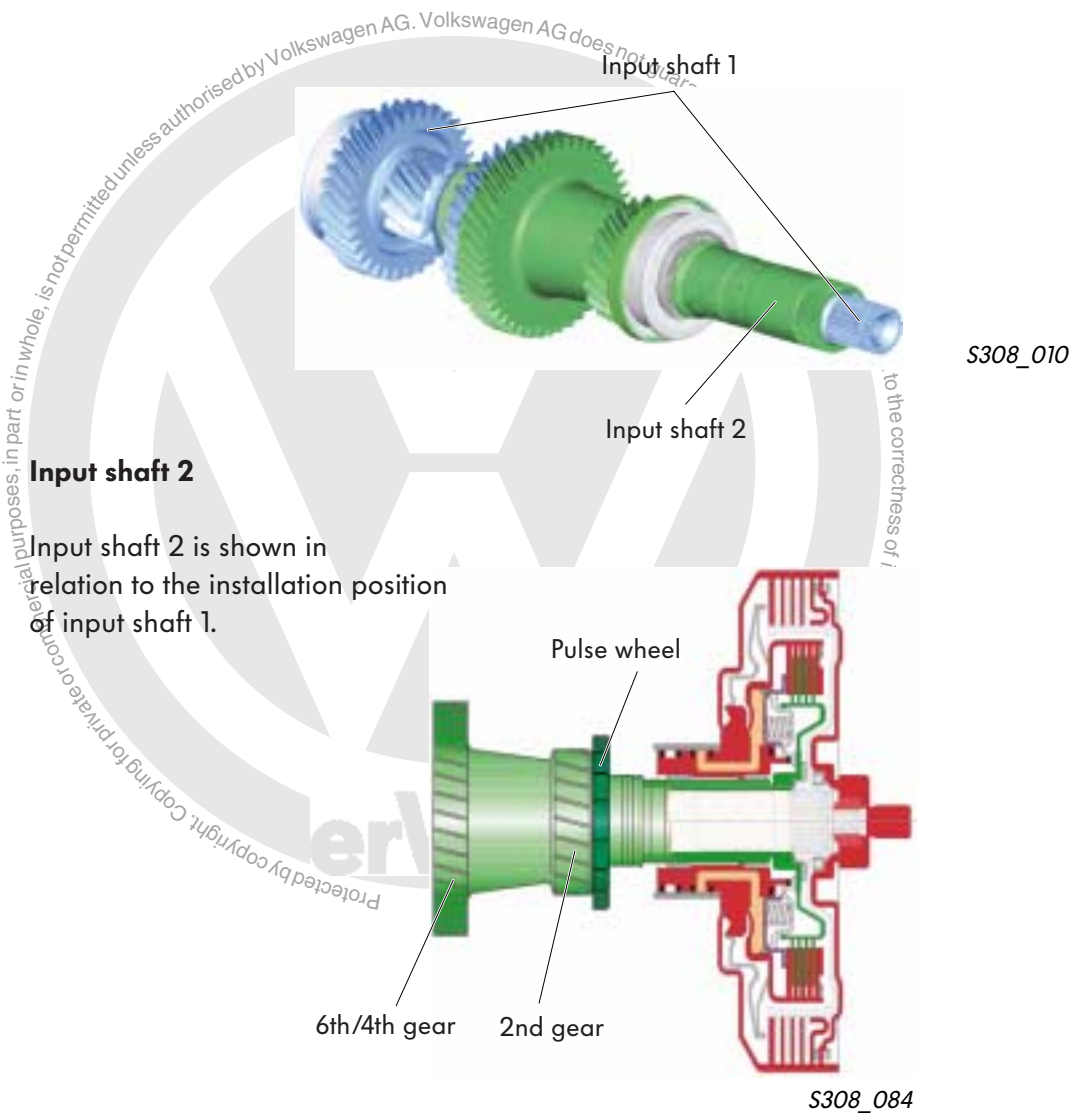

### Input shaft 2

Input shaft 2 is shown in relation to the installation position of input shaft 1.

Input shaft 2 is a hollow construction and is joined via splines to multi-plate clutch K2.

The helical gear wheels for 6th, 4th and 2nd gear can be found on input shaft 2.  
For 6th and 4th gear, a common gear wheel is used.

To measure the speed of this input shaft there is a pulse wheel for input shaft 2 speed sender G502 adjacent to the gear wheel for 2nd gear.

## Input shaft 1

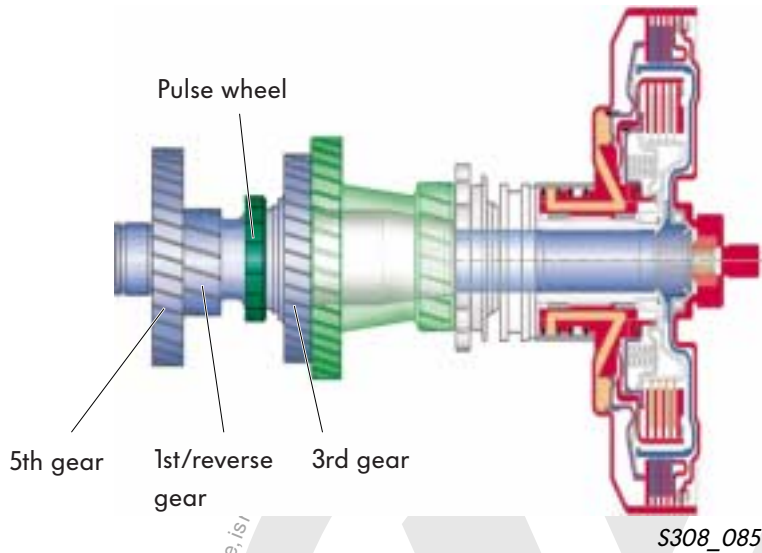

Input shaft 1 rotates inside input shaft 2, which is hollow. It is joined to multi-plate clutch K1 via splines.

Located on input shaft 1 are the helical gear wheels for 5th gear, the common gear wheel for 1st and reverse gear and the gear wheel for 3rd gear.

To measure the speed of this input shaft there is a pulse wheel for input shaft 1 speed sender G501 between the gear wheels for 1st/reverse gear and 3rd gear.



High powered magnets can destroy pulse wheels!

# Construction of DSG

## Output shafts

In line with the two input shafts, the direct shift gearbox also features two output shafts.

Thanks to the common use of gear wheels for 1st and reverse gear and 4th and 6th gear on the input shafts, it was possible to reduce the length of the gearbox.

### Output shaft 1

Stretched view

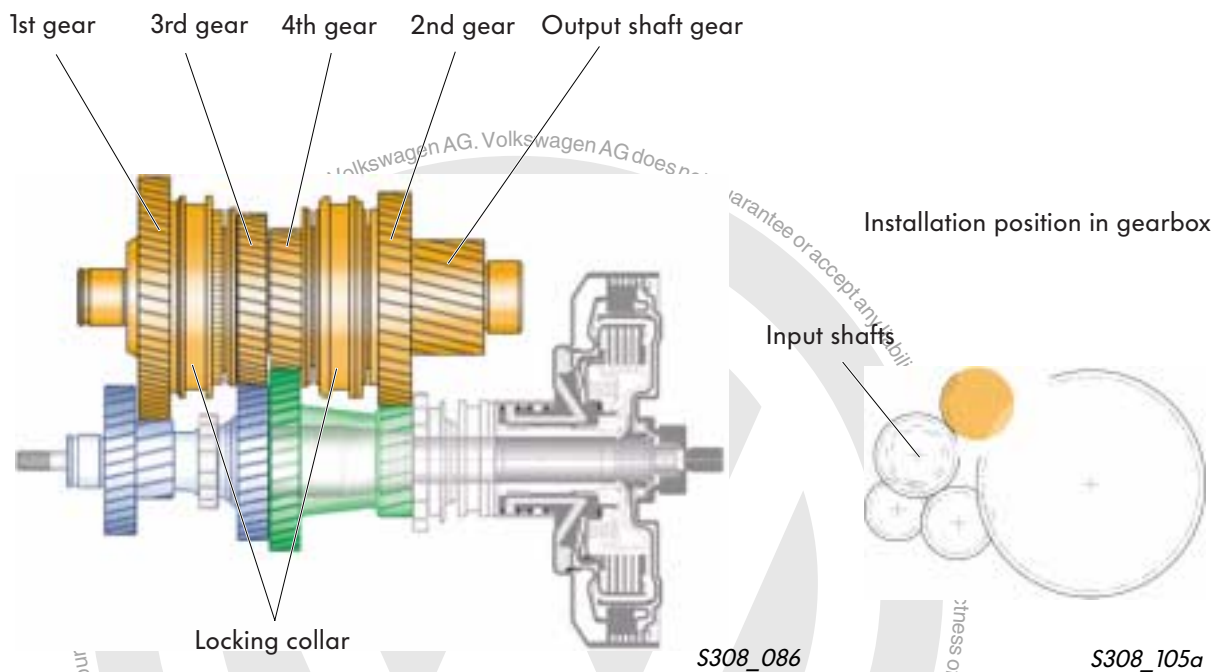

Located on input shaft 1 are

- the three-fold synchronised selector gears for 1st, 2nd, 3rd gears,
- the single synchronised selector gear for 4th gear and
- the output shaft gear for meshing into the differential.

The output shaft meshes into the final drive gear wheel of the differential.

## Output shaft 2

Stretched view

Installation position in gearbox

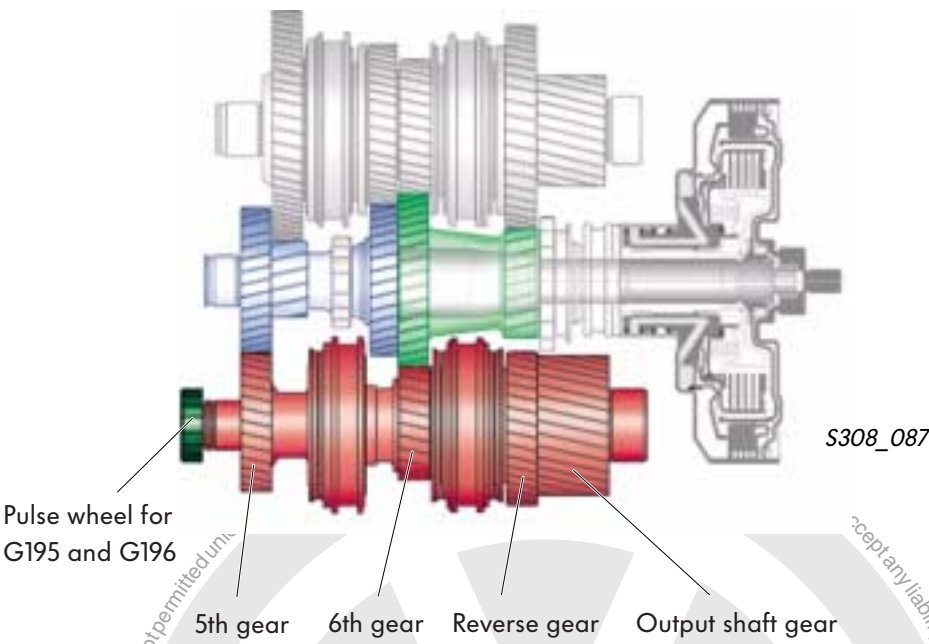
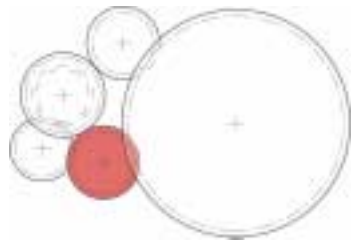

S308\_105b

Located on input shaft 2 are

- the pulse wheel for gearbox output speed
- the selector gears for 5th, 6th and reverse gears and
- the output shaft gear for meshing into the differential.

Both output shafts transmit the torque further to the differential via their output shaft gears.



# Construction of DSG

## Reverse shaft

The reverse shaft changes the direction of rotation of output shaft 2 and thereby also the direction of rotation of the final drive in the differential. It engages in the common gear wheel for 1st gear and reverse gear on input shaft 1 and the selector gear for reverse gear on output shaft 2.



Stretched view

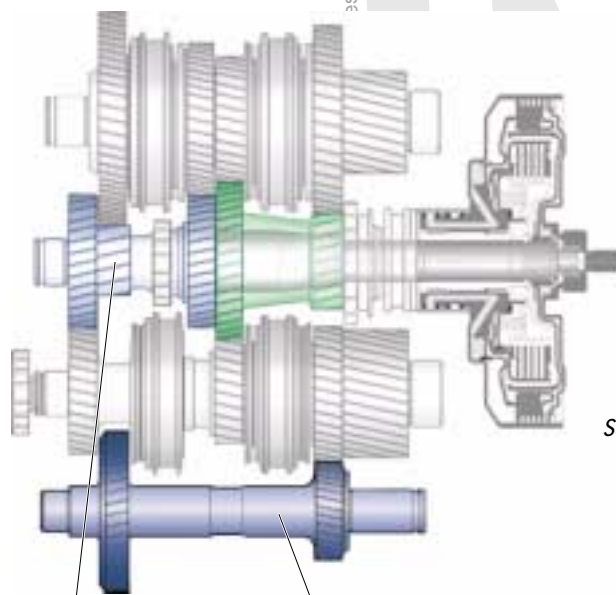

Gear wheel for 1st and reverse gear

Reverse shaft

Installation position in gearbox

S308\_088

S308\_105c



## Differential

Both output shafts transmit the torque to the input shaft of the differential.

The differential transmits the torque via the drive shafts to the road wheels.

Integrated in the differential is the parking lock gear.

Stretched view

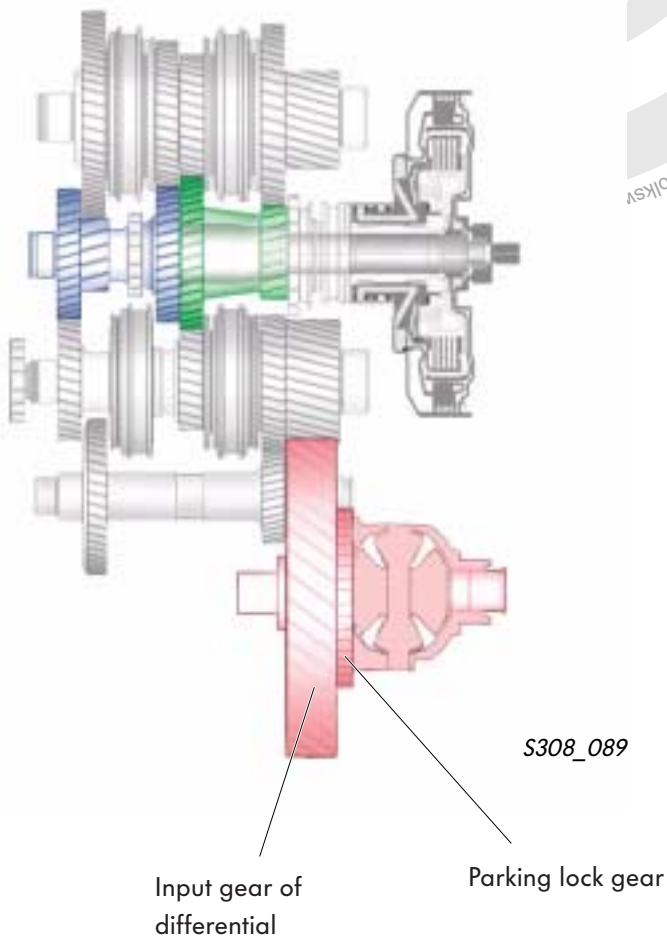

Installation position in gearbox

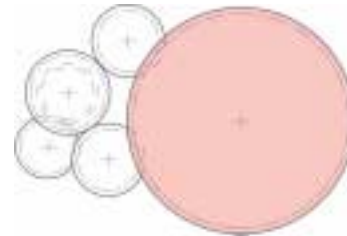

# Construction of DSG

## Parking lock

A parking brake is integrated in the differential to secure the vehicle in the parked position and to prevent the vehicle from creeping forwards or backwards unintentionally when the handbrake is not applied.

Engagement of the locking pawl is purely by mechanical means via a cable between the selector lever and the parking brake lever on the gearbox.

The cable is used exclusively to actuate the parking lock.

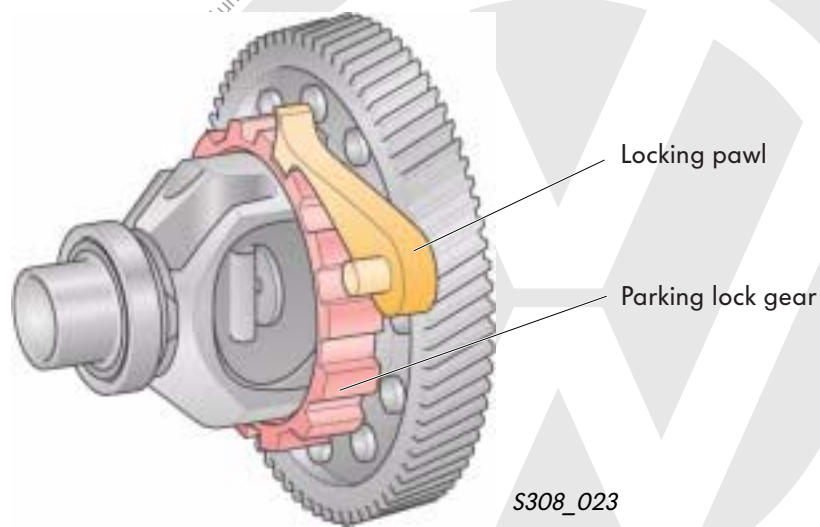

### This is how it works:

When the selector lever is moved to the "P" position, the parking lock is engaged. To do this, a locking pawl engages in the teeth of the parking lock gear.

The locking spring engages in the lever and holds the pawl in position.

When the pawl engages in one of the teeth of the parking lock gear, spring 1 is tensioned. If the vehicle begins to move, the pawl is pushed into the next gap on the parking lock gear by spring 1 as it releases its tension.

When the selector lever is moved out of position "P", the parking lock is deactivated. The slide is pushed to the right back into its start position and spring 2 pushes the locking pawl out of the gap in the parking lock gear.

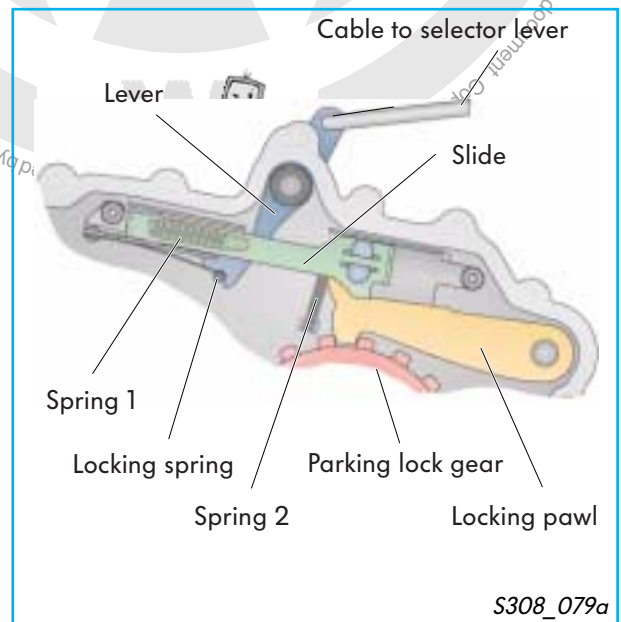

## Synchronisation

To engage a gear, the locking collar must be pushed onto the selector teeth of the selector gear.

The task of synchronisation is to balance the speed between the engaging gear wheels and the locking collar.

Molybdenum coated brass synchro-rings form the basis of synchronisation.

1st, 2nd and 3rd gears are equipped with three-fold synchronisation.

Compared with a simple cone system, a considerably larger friction area is provided. Synchronisation efficiency is increased as there is a greater surface area to transfer heat.

Balancing of the large speed differences between different selector gears is faster in the low gears. Less effort is required to engage the gears.

4th, 5th and 6th gears are equipped with a simple cone system. The speed differences here are not as great when gears are selected. The balancing of speed is therefore faster. Little effort is required for synchronisation.

Reverse gear is equipped with dual cone synchronisation.

Three-fold synchronisation comprises of

- an outer ring (synchro-ring)
- an intermediate ring
- an inner ring (2nd synchro-ring) and
- a friction cone on the selector gear/gear wheel

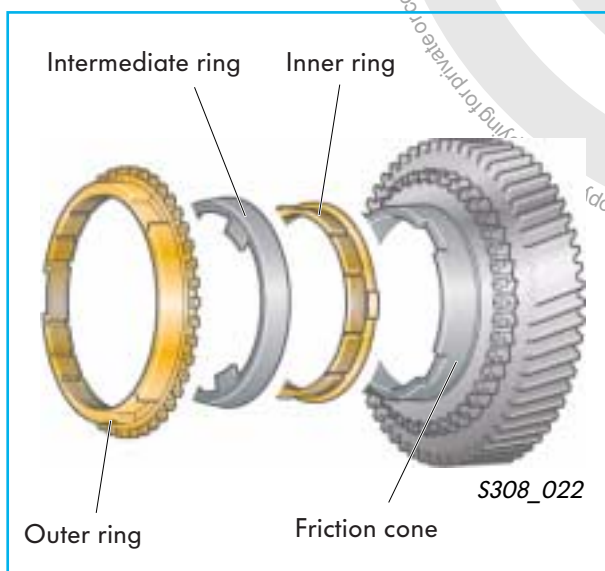

Simple synchronisation comprises of

- a synchro-ring and
- a friction cone on the selector gear/gear wheel

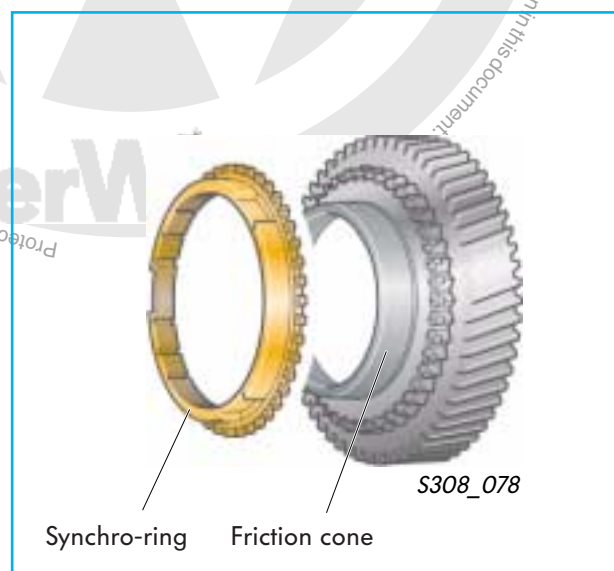

# Construction of DSG

## Torque transmission in the vehicle

The engine torque is transmitted via the dual mass flywheel to the direct shift gearbox.

On front-wheel drive vehicles, the drive shafts transmit the torque to the front road wheels.

On four-wheel drive vehicles, the torque is also transmitted to the rear axle via a bevel box.

A propshaft transmits the torque to a Haldex coupling. Integrated in this rear final drive is a differential for the rear axle.

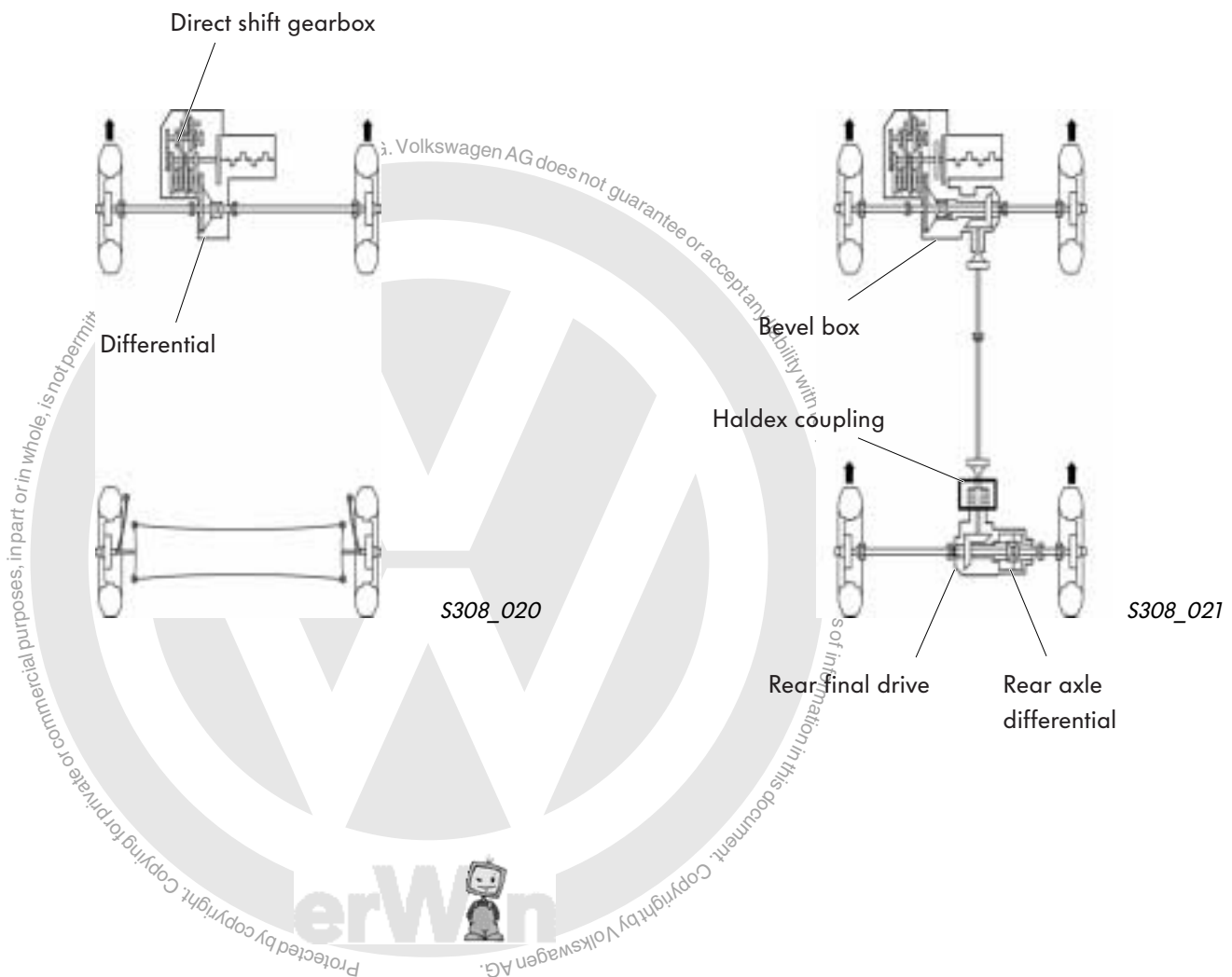

## Transmission route through gears

The torque in the gearbox is transmitted either via the outer clutch K1 or the inner clutch K2.

Each clutch drives an input shaft.

Input shaft 1 (inner) is driven by clutch K1 and

input shaft 2 (outer) is driven by clutch K2.

Power is transmitted further to the differential via

- output shaft 1 for 1st, 2nd, 3rd, 4th gears and
- output shaft 2 for 5th, 6th and reverse gears.

### 1st gear

Clutch K1

Input shaft 1

Output shaft 1

Differential

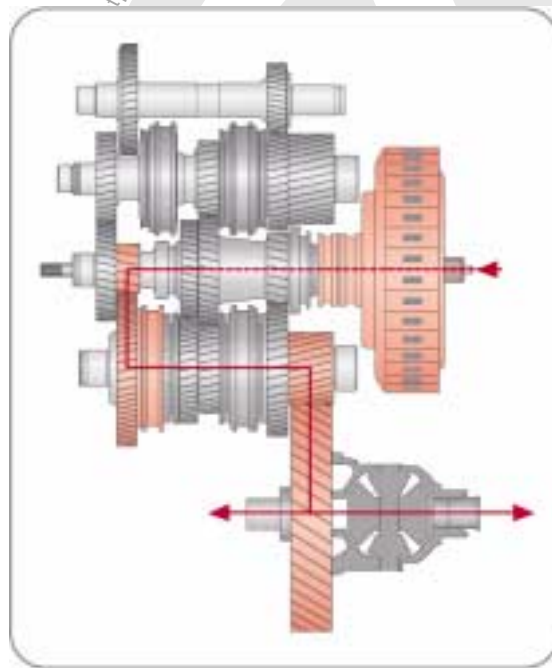

S308\_055\_1



For reasons of clarity, the flow of power is shown stretched in the diagram.



# Construction of DSG

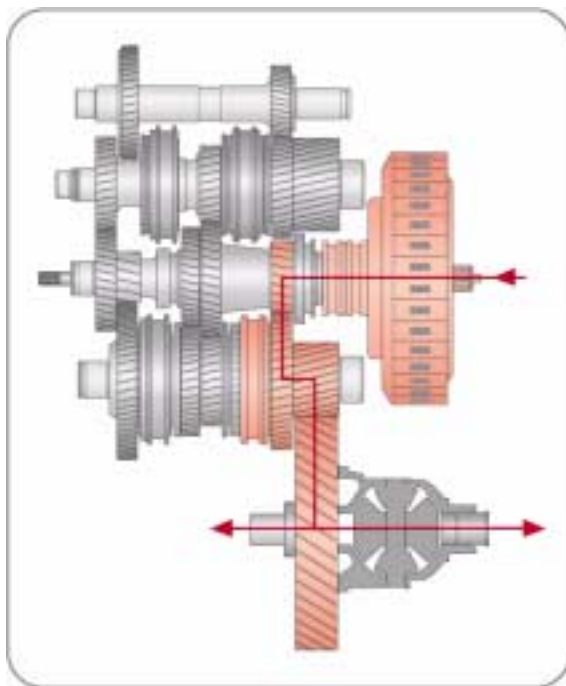

**2nd gear**  
Clutch K2  
Input shaft 2  
Output shaft 1  
Differential

G. Volkswagen AG does not guarantee or accept any liability

S308\_055\_2

Using for private or commercial purposes, in part or

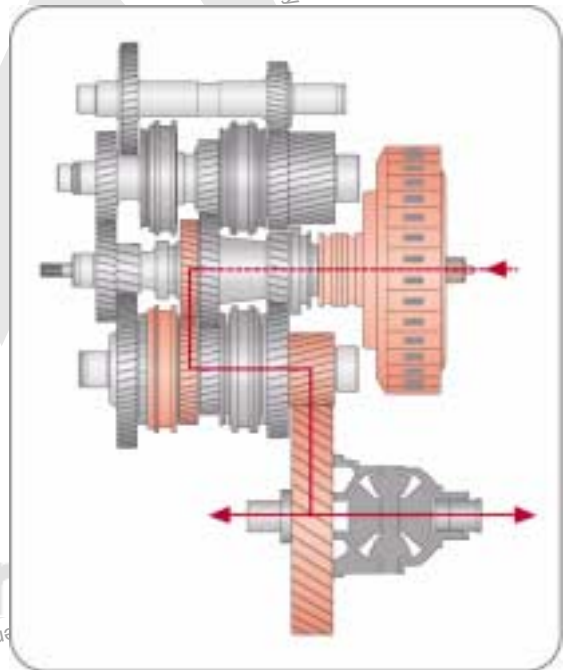

**3rd gear**  
Clutch K1  
Input shaft 1  
Output shaft 1  
Differential

S308\_055\_3

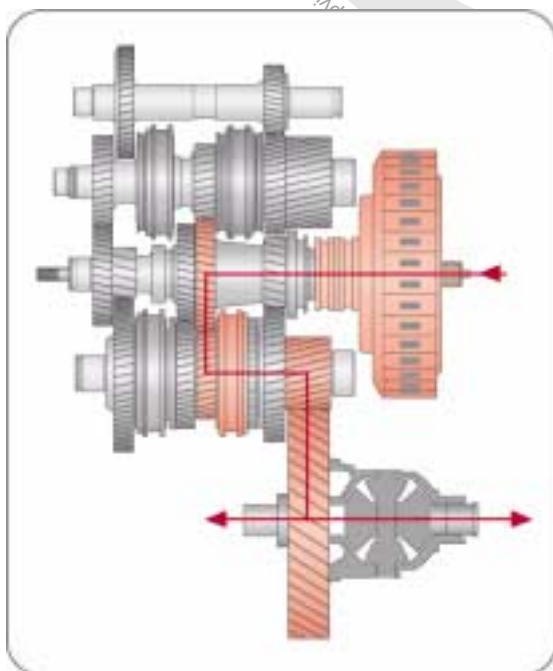

**4th gear**  
Clutch K2  
Input shaft 2  
Output shaft 1  
Differential

S308\_055\_4

part or in whole, is not permitted unless authorised by Volkswagen AG. Volkswagen AG do

**5th gear**

- Clutch K1
- Input shaft 1
- Output shaft 2
- Differential

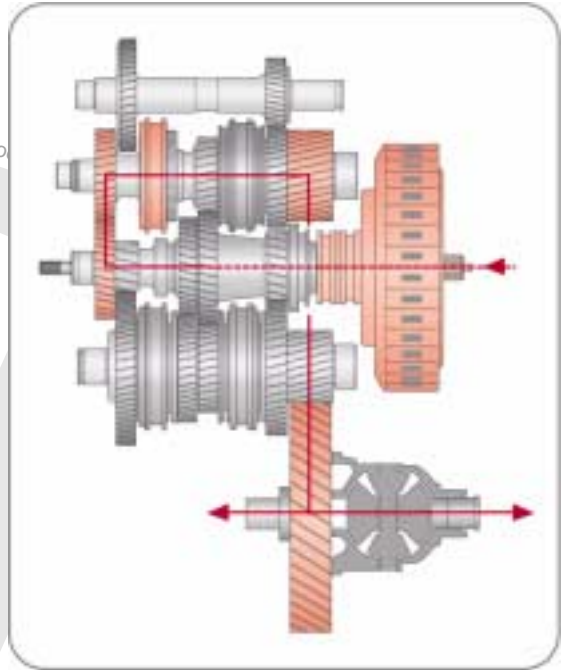

S308\_055\_5

**6th gear**

- Clutch K2
- Input shaft 2
- Output shaft 2
- Differential

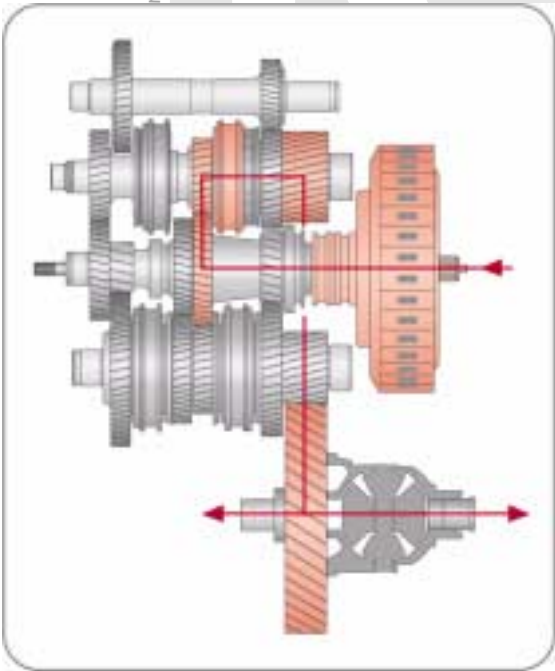

S308\_055\_6

**Reverse**

- Clutch K1
- Input shaft 1
- Reverse shaft
- Output shaft 2
- Differential

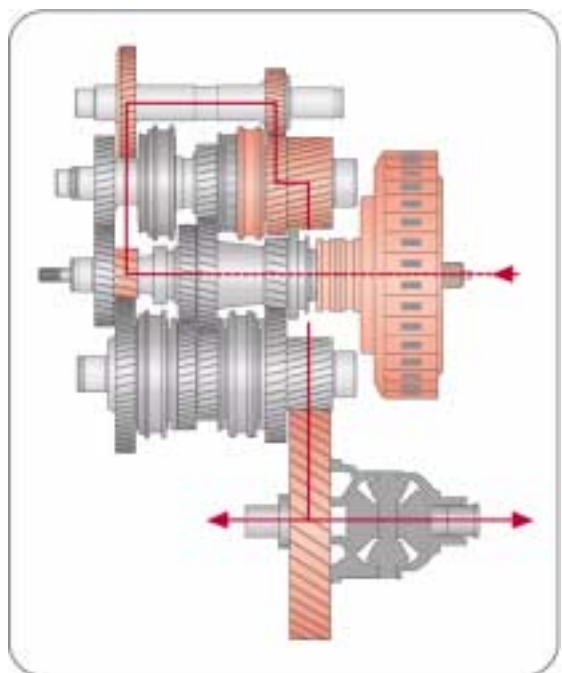

S308\_055\_R

The change in direction of rotation for reverse gear is carried out via the reverse shaft.



# Mechatronics module

## Mechatronics

The mechatronics are housed in the gearbox, surrounded by DSG oil. They comprise of an electronic control unit and an electro-hydraulic control unit.

The mechatronics form the central control unit in the gearbox. All sensor signals and all signals from other control units come together at this point and all actions are initiated and monitored from here.

Housed in this compact unit are twelve sensors. Only two sensors are located outside the mechatronics system.

By hydraulic means, it controls or regulates eight gear actuators via six pressure modulation valves and five selector valves and it also controls the pressure and flow of cooling oil from both clutches.

The mechatronics control unit learns (adapts) the position of the clutches, the positions of the gear actuators when a gear is engaged and the main pressure.



Electro-hydraulic control unit

Central connector to vehicle

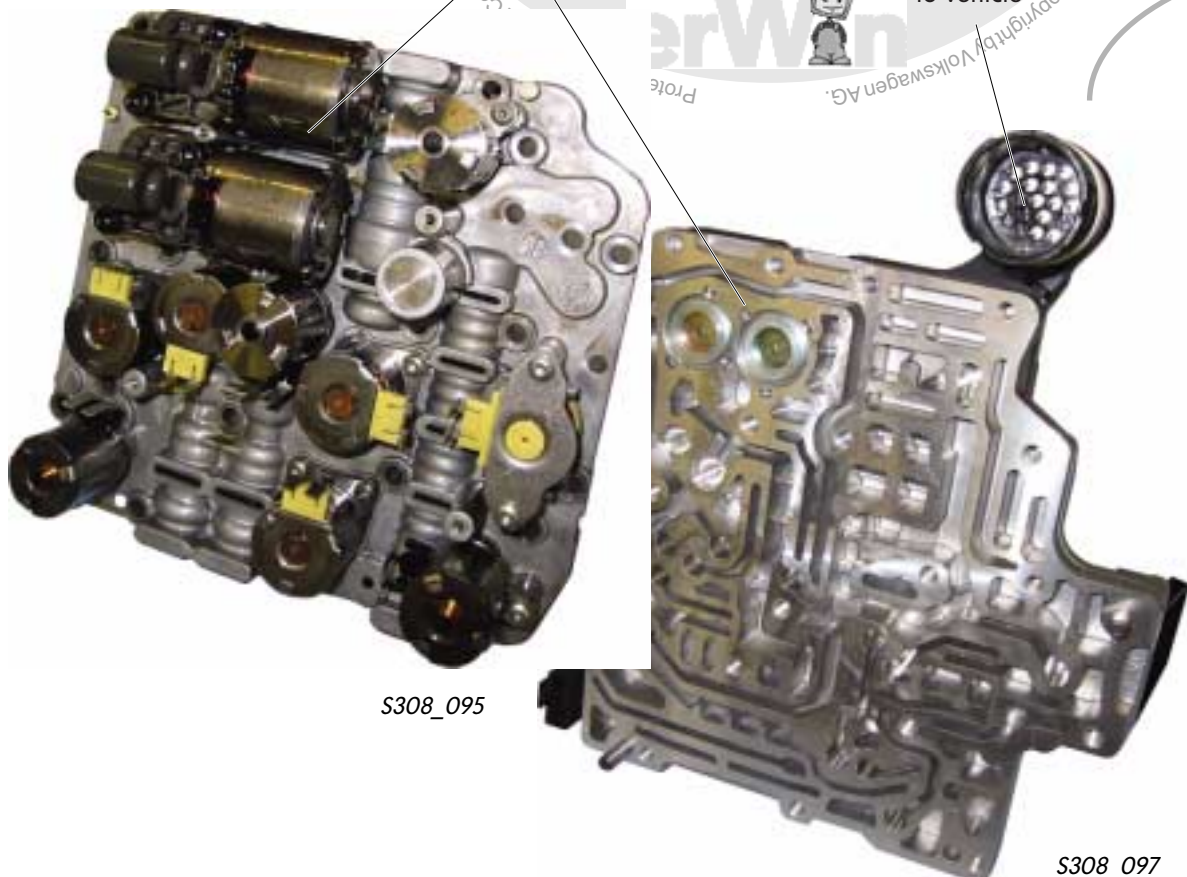

S308\_095

S308\_097

The advantages of this compact unit are:

- The majority of sensors are integrated within.
- The electric actuators are located directly on the mechatronics.
- The electrical interfaces required on the vehicle side are joined at one central connector.

As a result of these measures, the number of connectors and amount of wiring has been reduced. That means there is greater electrical efficiency and lower weight.

It also means that a high degree of thermal and mechanical stress is placed on the control unit. Temperatures of  $-40\text{ }^{\circ}\text{C}$  to  $+150\text{ }^{\circ}\text{C}$  and mechanical vibrations of up to  $33\text{ g}$  should not be allowed to impair the operability of the vehicle.

$g$  = acceleration of gravity, acceleration of an object influenced by the gravitational pull of the earth towards the earth's core

$$1\text{ g} = 9,81\text{ m/s}^2$$

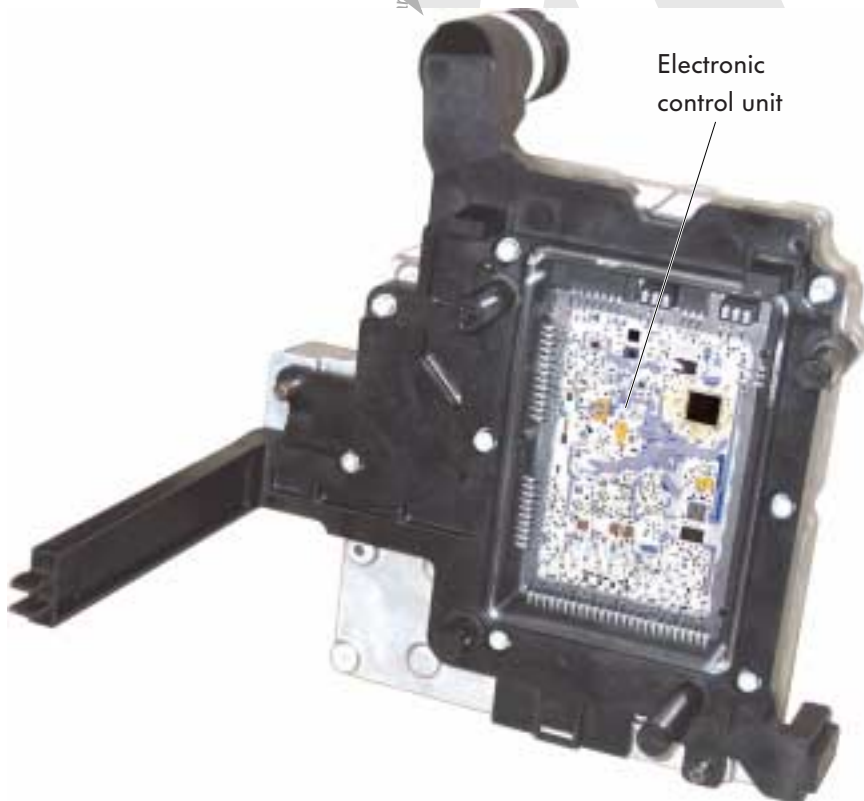

S308\_096



# Electro-hydraulic control unit

## Electro-hydraulic control unit

The electro-hydraulic control unit is integrated in the mechatronics module.

Housed within the control unit are all the solenoid valves, pressure control valves and hydraulic selectors and the multiplexer.

- N88 - Solenoid valve 1 (gear actuator valve)
- N89 - Solenoid valve 2 (gear actuator valve)
- N90 - Solenoid valve 3 (gear actuator valve)
- N91 - Solenoid valve 4 (gear actuator valve)
- N92 - Solenoid valve 5 (multiplexer valve)
- N215 - Pressure control valve 1 (clutch K1)
- N216 - Pressure control valve 2 (clutch K2)

In addition, there is a pressure release valve on the hydraulic module. It prevents pressure from rising to a level that could damage the hydraulic selectors.

- N217 - Pressure control valve 3 (main pressure)
- N218 - Pressure control valve 4 (cooling oil)
- N233 - Pressure control valve 5 (safety 1)
- N371 - Pressure control valve 6 (safety 2)
- A - Pressure release valve
- B - Printed circuit

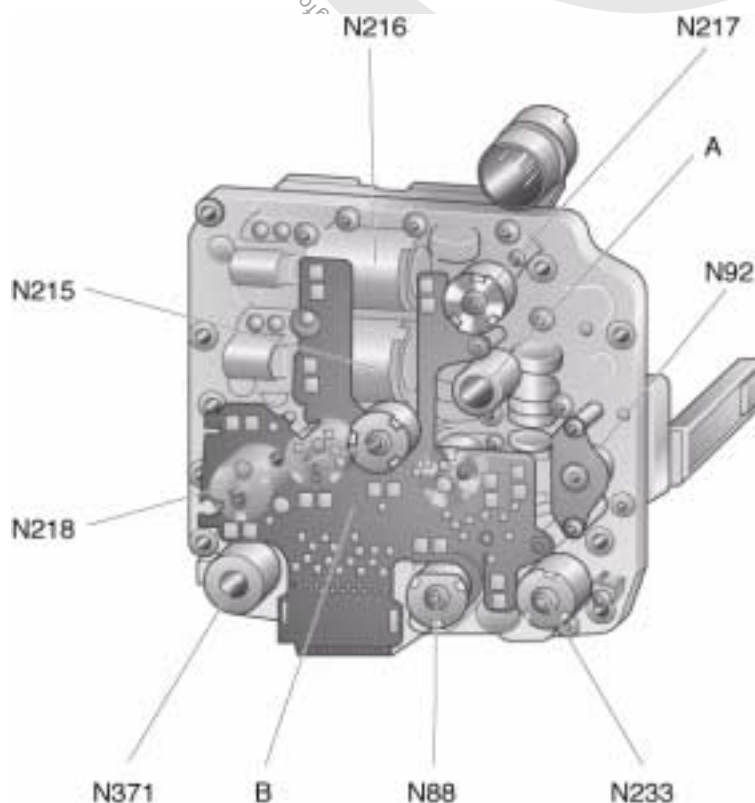

S308\_033

The valves have different selector characteristics depending on their function.

There are

- "yes/no" selector valves and
- modulation valves

to choose from.

The "yes/no" valves are made up of

- the gear actuator valves and
- the multiplexer selector valve.

The modulation valves are made up of

- the main pressure valve
- the cooling oil valve
- the clutch valves and
- the safety valves.

Once the printed circuit is removed, the gear actuator valves N89, N90 and N91 become visible.

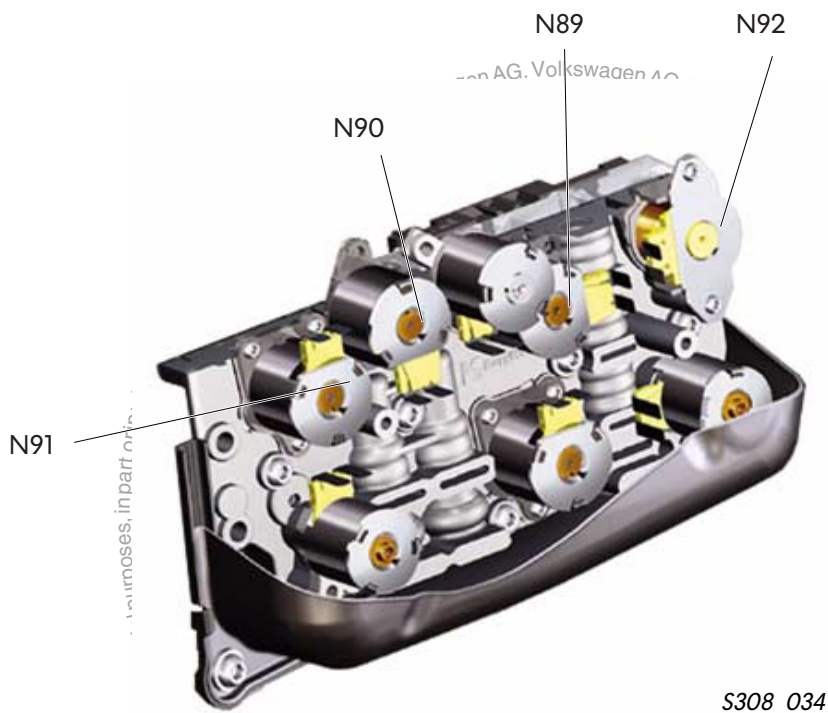

Protected by copyright. Copying for private purposes, in part or in whole, is prohibited. Copyright by Volkswagen AG. We accept no liability with respect to the correctness of information in this document.

# Oil lubrication circuit

## Oil lubrication circuit

The DSG has a common lubrication circuit for all gearbox functions.  
The volume of direct selection gear oil is 7.2 litres.

The oil must meet the following demands:

- Assure clutch regulation and hydraulic control
- Stable viscosity across the whole temperature range
- Resistant to high mechanical stress
- Does not allow foaming

The oil has the task of:

- lubricating/cooling the double clutch, the gear wheels, shafts, bearings and parts of synchronisation and
- actuation of the double clutch and gear actuator plungers

The oil temperature is kept from rising above 135 °C by an oil cooler, which is regulated by coolant from the engine.

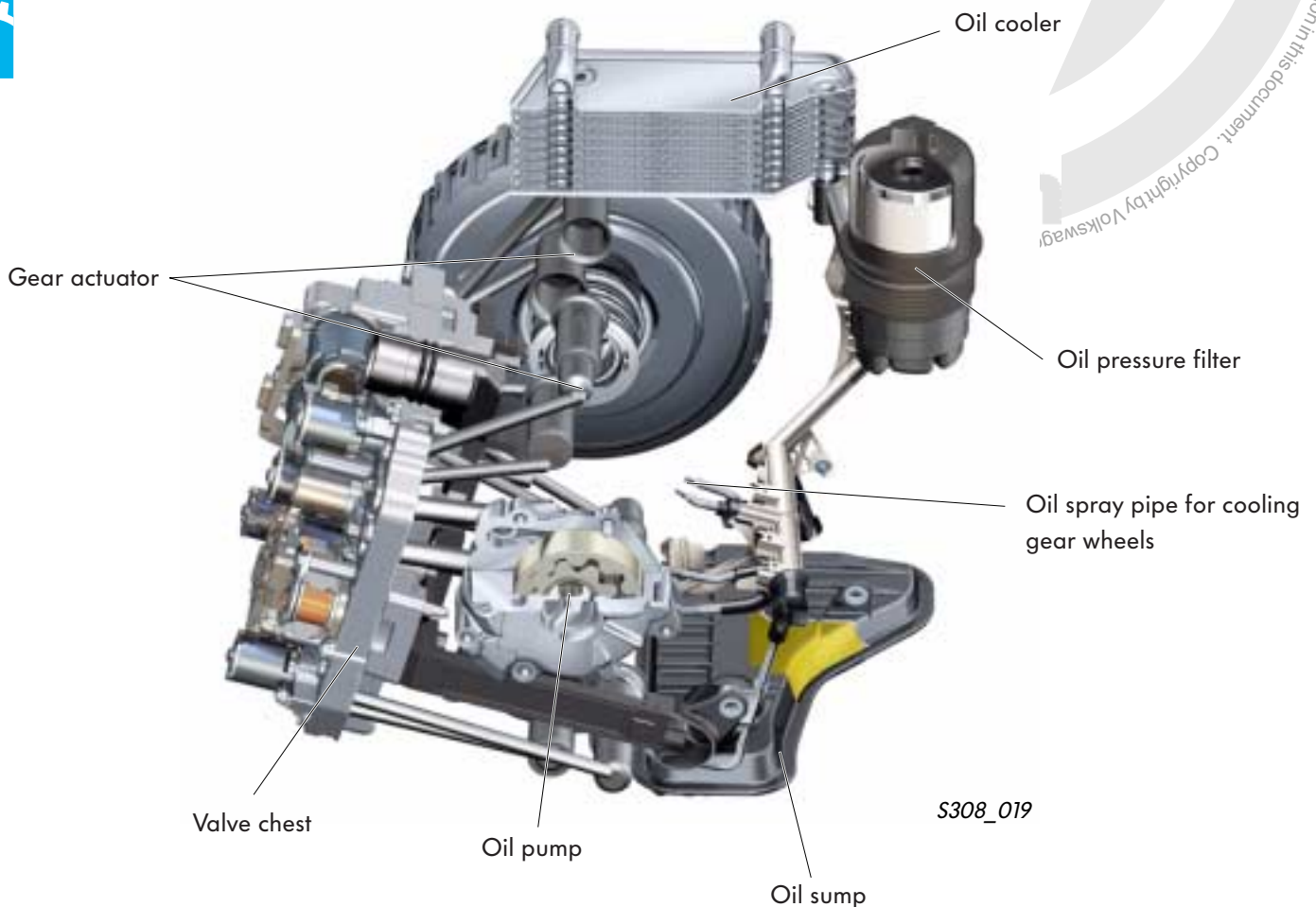

## Oil pump

An internal gear crescent pump draws the DSG oil in and builds up the oil pressure necessary for actuation of the hydraulic components. It allows a maximum output of 100 litres per minute and a main pressure of 20 bar.

The oil pump supplies

- the multi-plate clutches
- the clutch cooling
- the gear selection hydraulics
- the gear wheel lubrication

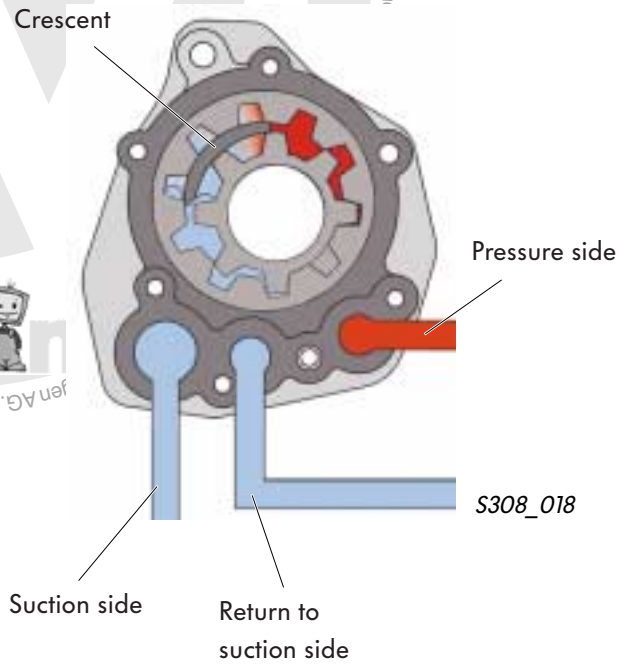

The oil pump is driven by a pump shaft, which rotates at engine speed. This pump shaft is located as a third shaft within the two meshed input shafts 1 and 2.

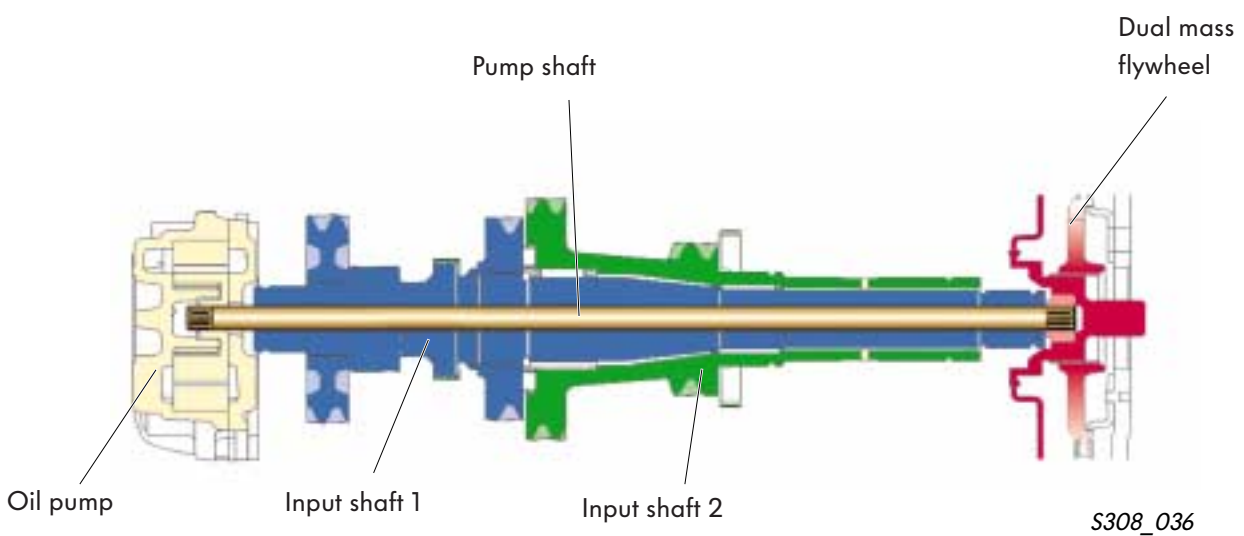

# Oil lubrication circuit

Oil lubrication circuit diagram

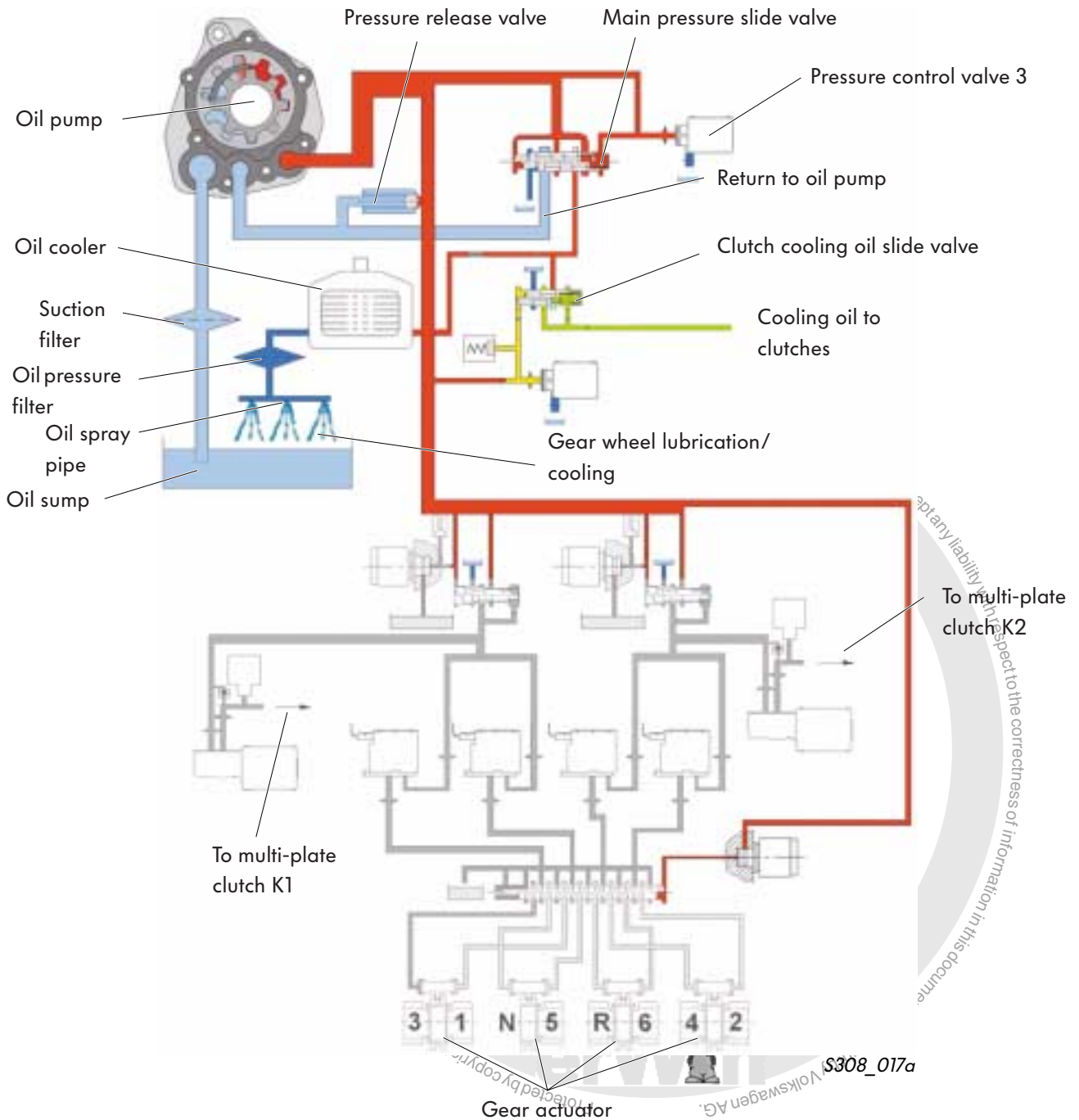

**Colour key**

- Regulated pressure, working pressure
- Controlled pressure, clutch cooling
- Non-controlled pressure
- Return to oil sump

## Explanation of oil lubrication circuit

The oil pump draws the oil out of the oil sump via the suction filter and supplies it under pressure to the main pressure slide valve.

The main pressure is regulated by pressure control valve 3 - the main pressure control valve. The main pressure valve controls the working pressure in the direct shift gearbox.

Beneath the main pressure slide valve is a channel that returns oil to the suction side of the pump.

The other oil channel branches off in two directions.

One channel leads to the oil cooler and then back to the oil sump via the pressure filter.

The other channel directs the flow of oil to the clutch cooling oil slide valve.

The working pressure, regulated by pressure control valve 3, is used by the gearbox to actuate the multi-plate clutches and to select the gears.

The oil cooler is incorporated in the cooling circuit of the engine.

The oil pressure filter can be found on the outside of the gear casing (gearbox).

The pressure release valve ensures that oil pressure does not rise above 32 bar.

Oil reaches the gear wheels directly by way of the oil spray pipe.

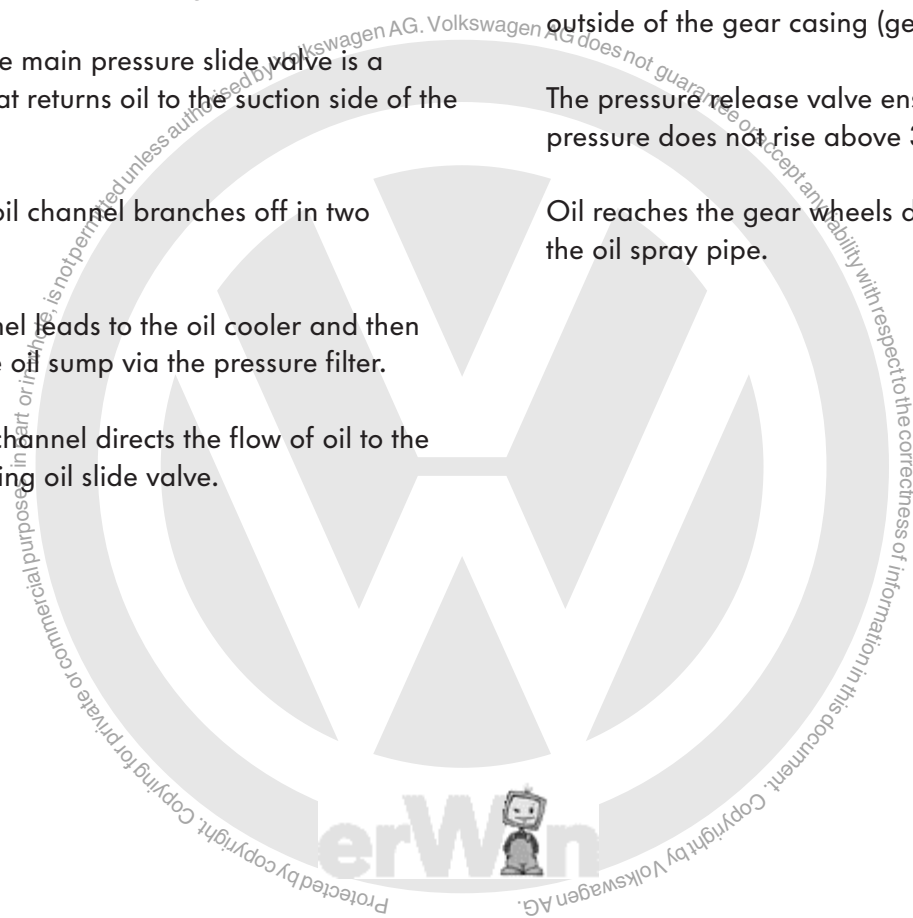

# Oil lubrication circuit

## Hydraulic elements in oil lubrication circuit

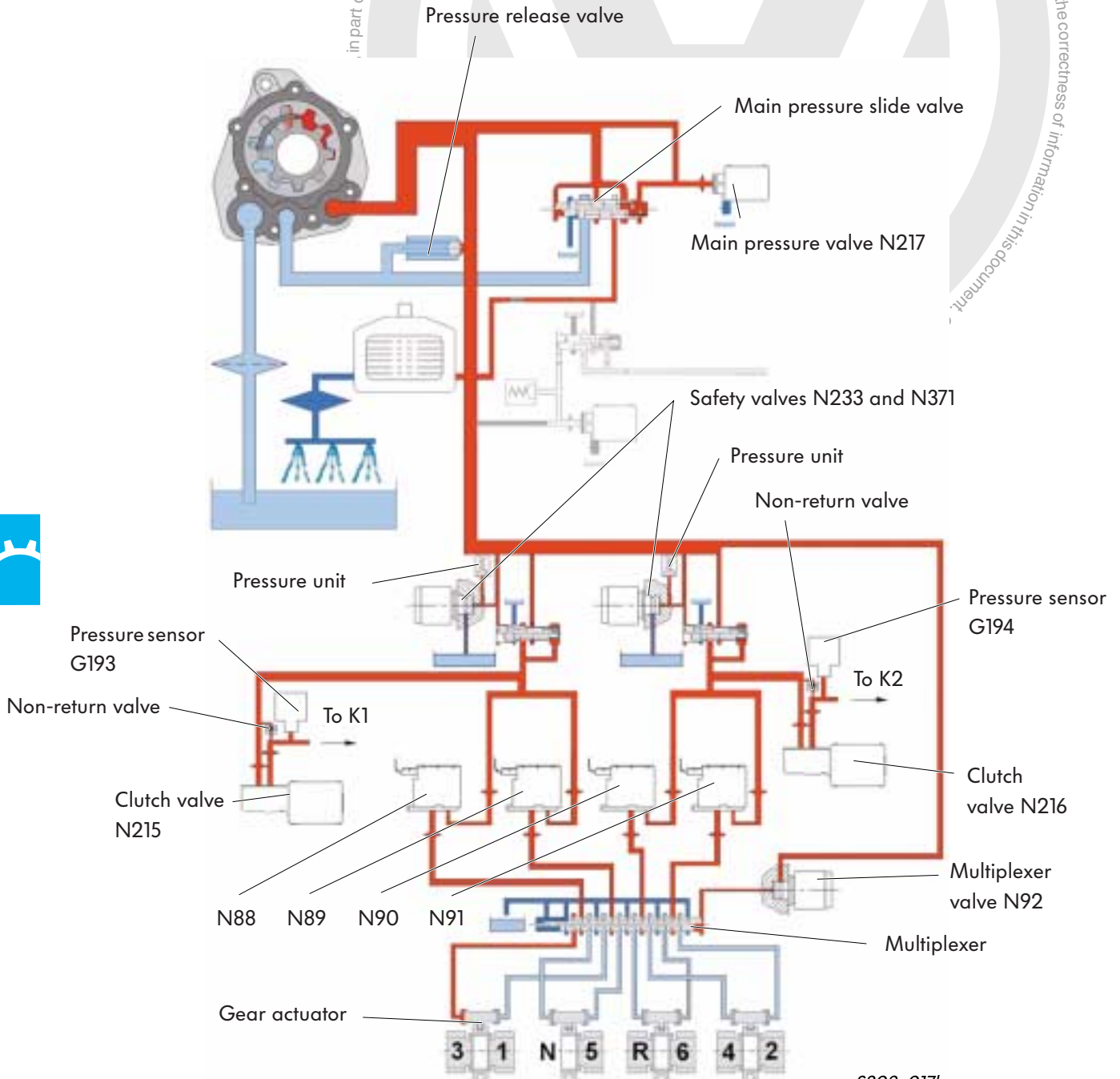

### Colour key

- Regulated pressure, working pressure
- Return to oil sump
- Non-controlled pressure

## Electro-hydraulic control of oil lubrication circuit

### Main pressure valve N217

This valve is actuated by the electronic control unit and it controls the main pressure slide valve.

In this way, the working pressure in the direct shift gearbox hydraulic system is regulated.

The flow of oil

- through oil cooler/pressure filter/spray pipe,
- back to oil pump

is controlled by the main pressure valve.

Main pressure is made available to both clutch valves N215 and N216 to open and close the clutches K1 and K2 and to the four gear actuator valves N88, N89, N90 and N91 for gear engagement.

### Multiplexer valve N92

This valve actuates the multiplexer. The multiplexer (multiplier) allows control of the eight gear actuator cylinders using just four solenoid valves.

The multiplexer is pushed into its base position by means of a spring.

In the base position, 1st, 3rd, 6th and reverse gears can be selected.

If the multiplexer valve N92 is energised, oil pressure is free to flow to the multiplexer. This results in the multiplexer being pressed against spring pressure into the operating position.

In this way, 2nd, 4th, 5th and neutral gears can be selected.

### Safety valves

One safety valve each for clutch K1 (N233) and clutch K2 (N371) allow rapid opening of each respective clutch. This becomes necessary if and when the actual clutch pressure rises above the specified pressure.

### Pressure sensors G193 and G194

The pressure sensors G193 and G194 control the clutch pressure of clutches K1 and K2.

A pressure release valve prevents excessive rise in main pressure in the event of a defective main pressure slide valve.

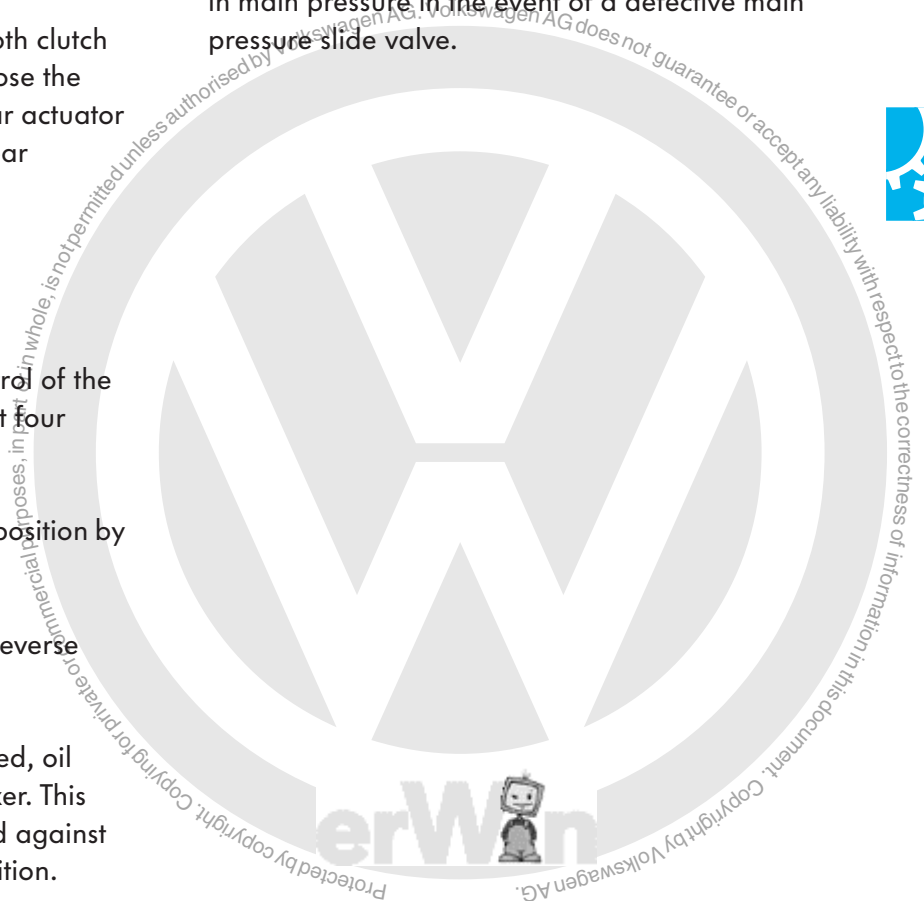

# Oil lubrication circuit

## Clutch cooling oil system

The mechanical friction in the multi-plate clutches results in an increase in temperature in the double clutch.

To prevent this from overheating, it has to be cooled.

To cool the clutches, there is a separate clutch cooling oil circuit within the oil lubrication circuit.

The cooling oil circuit is made up of the cooling oil slide valve and the pressure control valve 4 N218 (clutch cooling oil valve).

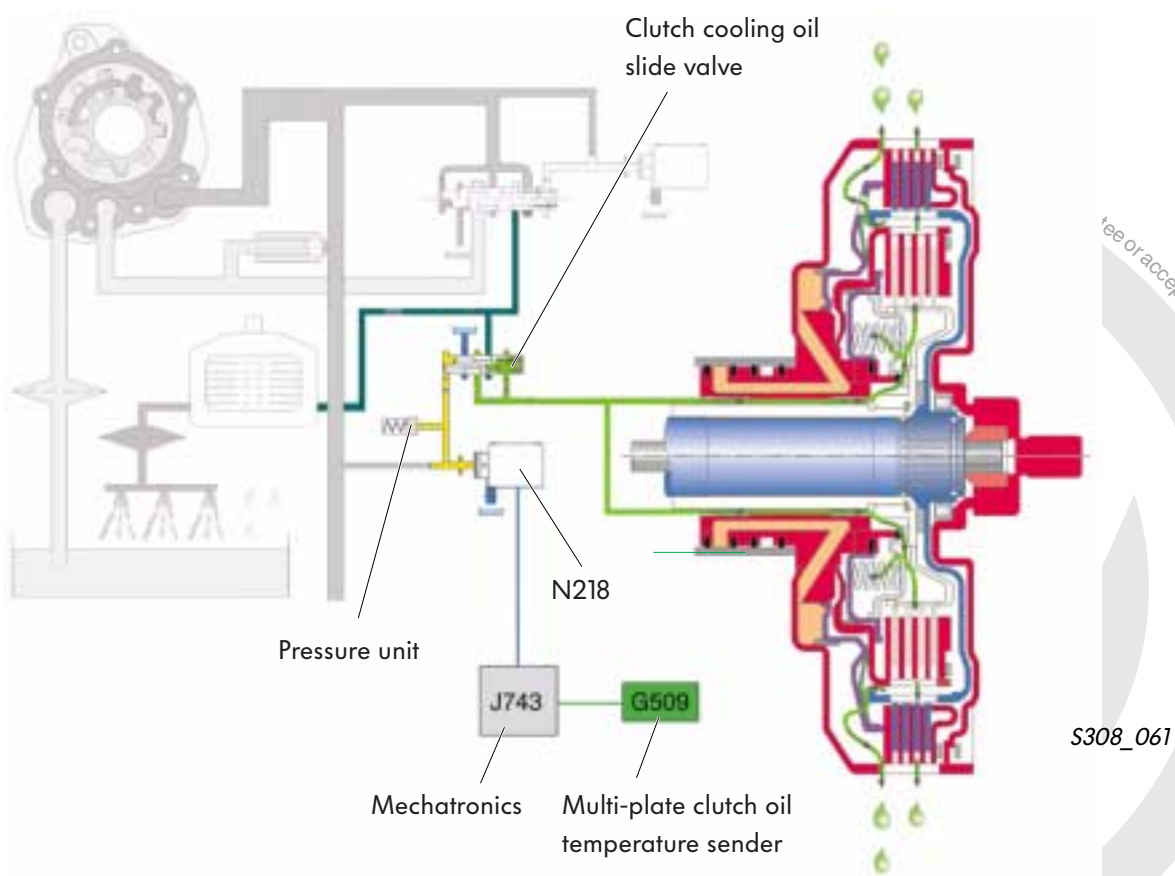

### This is how it works:

The multi-plate clutch oil temperature sender G509 measures the oil temperature directly at the multi-plate clutch oil outlet.

Depending on the oil temperature measured, the control unit will activate the pressure control valve.

The pressure control valve increases or reduces the oil pressure at the cooling oil slide valve depending on the temperature measured. The cooling oil slide valve opens or closes the oil channel to the multi-plate clutches depending on the oil pressure.

The maximum cooling oil volume is 20 litres/minute. The maximum cooling oil pressure is 2 bar.

## Gear selection

The gears are selected via selector forks in the same way as a manual gearbox. Two gears are selected by each selector fork.

Actuation of the selector forks is hydraulic on the direct shift gearbox and not by means of selector rods, as on conventional manual gearboxes.

The selector forks run on ball bearings in a cylinder.

To select a gear, oil is fed into the left cylinder by the mechatronics. Since the right cylinder is not under pressure, the selector fork is moved and actuates the locking collar. This results in gear engagement.

Once the gear is engaged, the selector fork is moved to a "no pressure" position.

The gear is held in place by a chamfer on the selector teeth and by a locking mechanism on the selector fork.

When the selector fork is not actuated, it is held in place in the gear casing (gearbox) by a locking mechanism.

A permanent magnet is fitted to each selector fork. The permanent magnet allows the travel sensor in the mechatronics to detect the precise position of the selector forks.

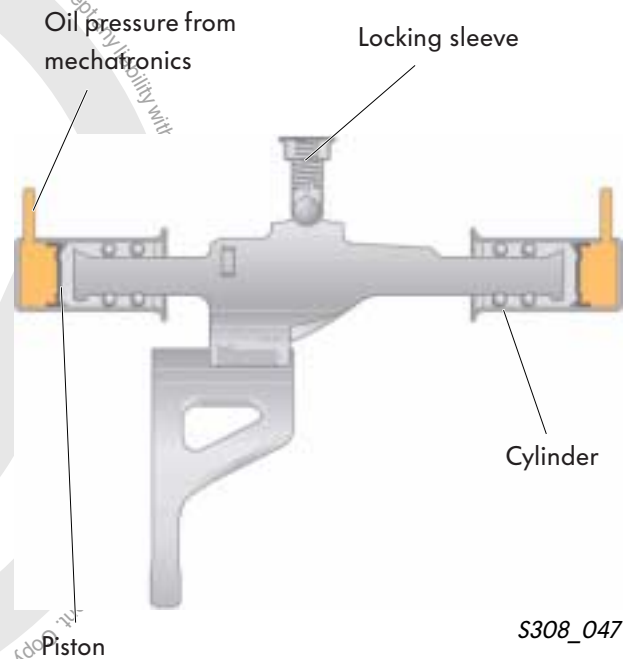

S308\_047

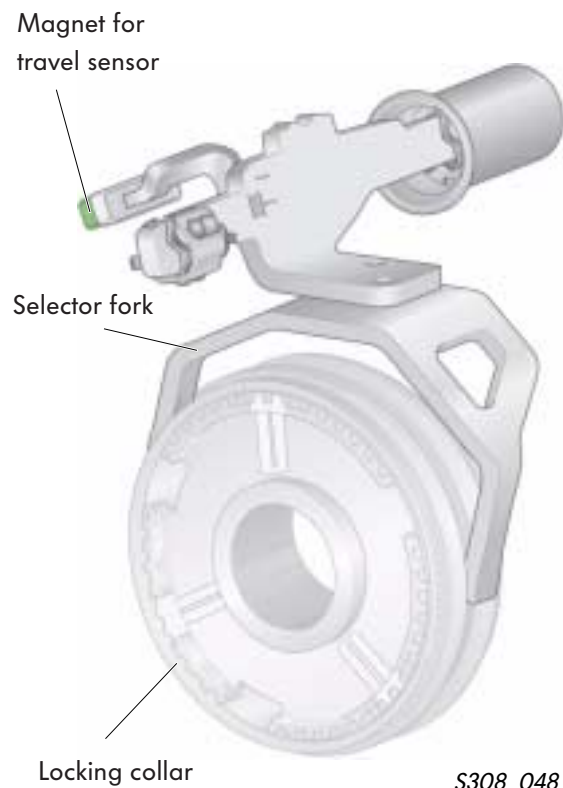

S308\_048



# System overview

## Sensors

Multi-plate clutch oil temperature sender G509  
 Gearbox input speed sender G182

Gearbox output speed senders G195 and G196  
 Speed senders for input shafts 1 and 2 G501 and G502

Sender 1 G193 and sender 2 G194 for hydraulic pressure

Gear oil temperature sender G93  
 Control unit temperature sender G510

Travel sensors 1 to 4 for gear actuators G487, G488, G489, G490

Steering wheel Tiptronic switches E438 and E439

## Direct shift gearbox mechatronics J743

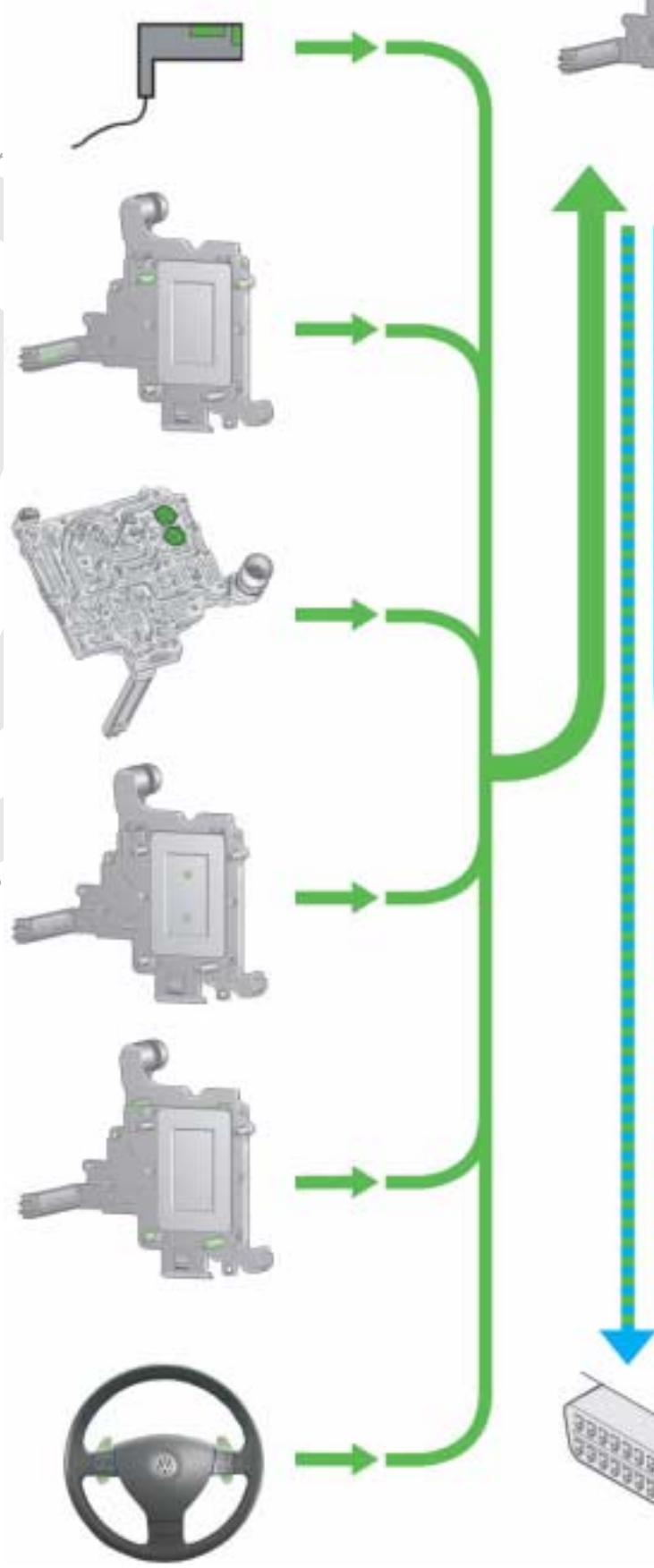
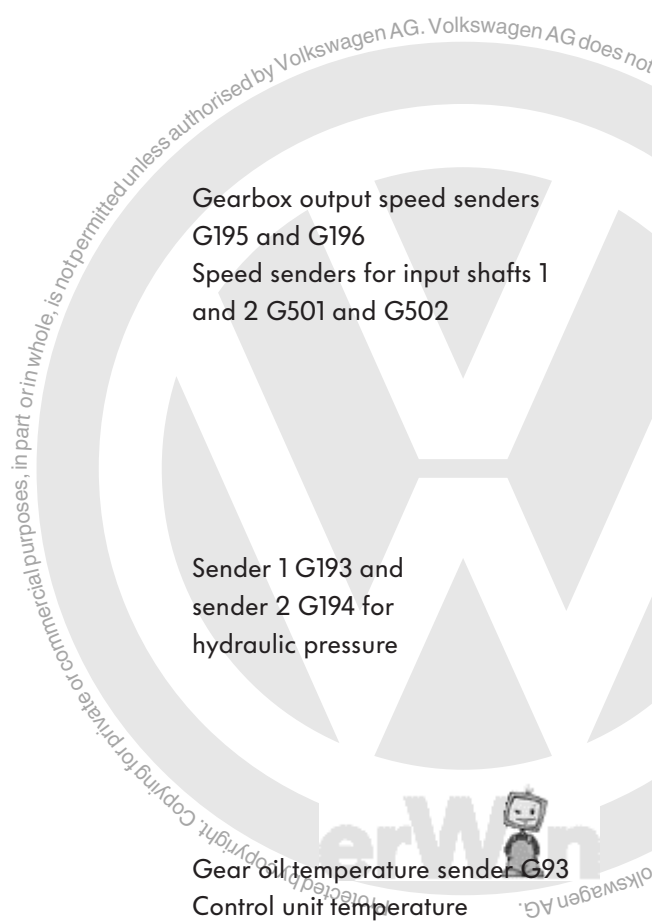

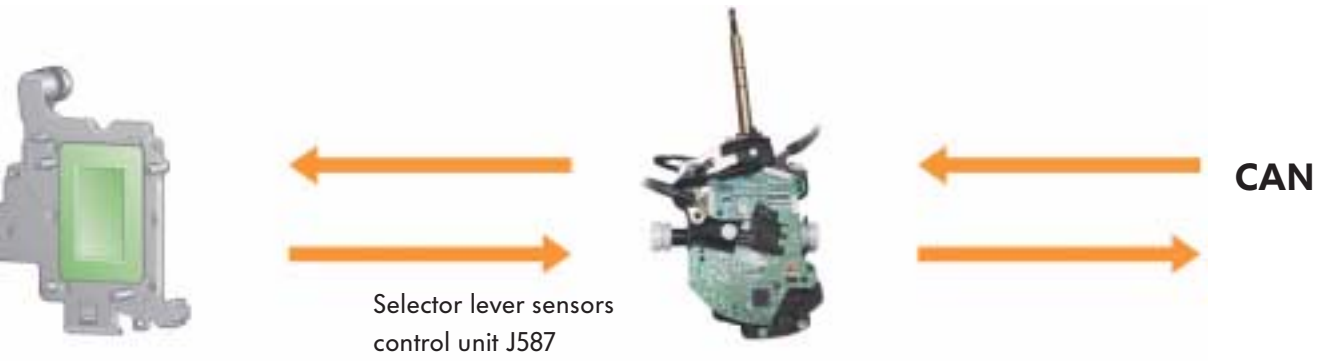

**Actuators**

Selector lever lock solenoid N110



Pressure control valves N215, N216, N217



Solenoid valves N88, N89, N90, N91, N92, N218, N233, N371

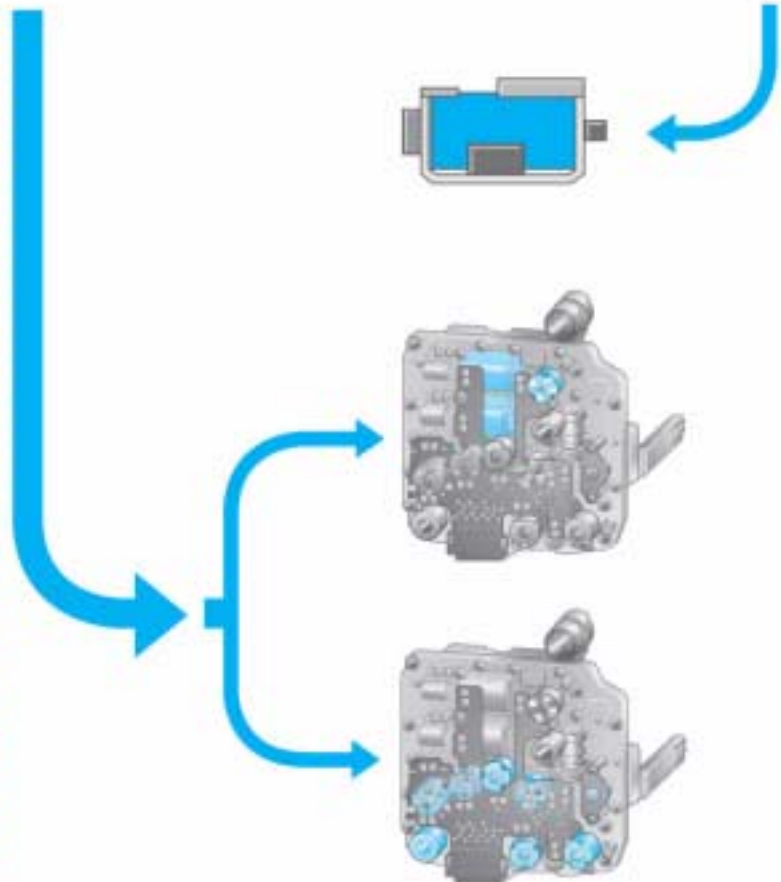

Diagnosis connector



# Sensors

## Gearbox input speed sender G182

The gearbox input speed sender is inserted in the gear casing (gearbox).

It scans the outside of the double clutch and picks up the gearbox input speed.

The gearbox input speed is the same as the engine speed.

The speed sender works on the Hall sender principle.

In the housing of this sender is also sender G509. Both senders are connected to the mechatronics by means of electrical wiring.



### Signal application

The gearbox input speed signal is used as a figure for calculation of slip at the multi-plate clutches.

To perform this calculation, the control unit also requires the signals from senders G501 and G502.

The control unit is able to open and close the clutches more precisely with the aid of the clutch slip figure.

### Effects of signal failure

In the event of signal failure, the control unit uses engine speed from the CAN as a substitute value.



## Input shaft speed sender 1 G501 and input shaft speed sender 2 G502

Both senders are located in the mechatronics.  
Speed sender G501 picks up the speed of input shaft 1.

Speed sender G502 picks up the speed of input shaft 2.

Both senders are of the Hall type.

To detect the speed, each sender scans a pulse wheel on its shaft.

The pulse wheel comprises of a sheet metal element.

The sheet metal element is treated with a metallic rubber coating. This coating features small magnets around its circumference, polarised to north and south.

Between the individual magnets is an air gap.

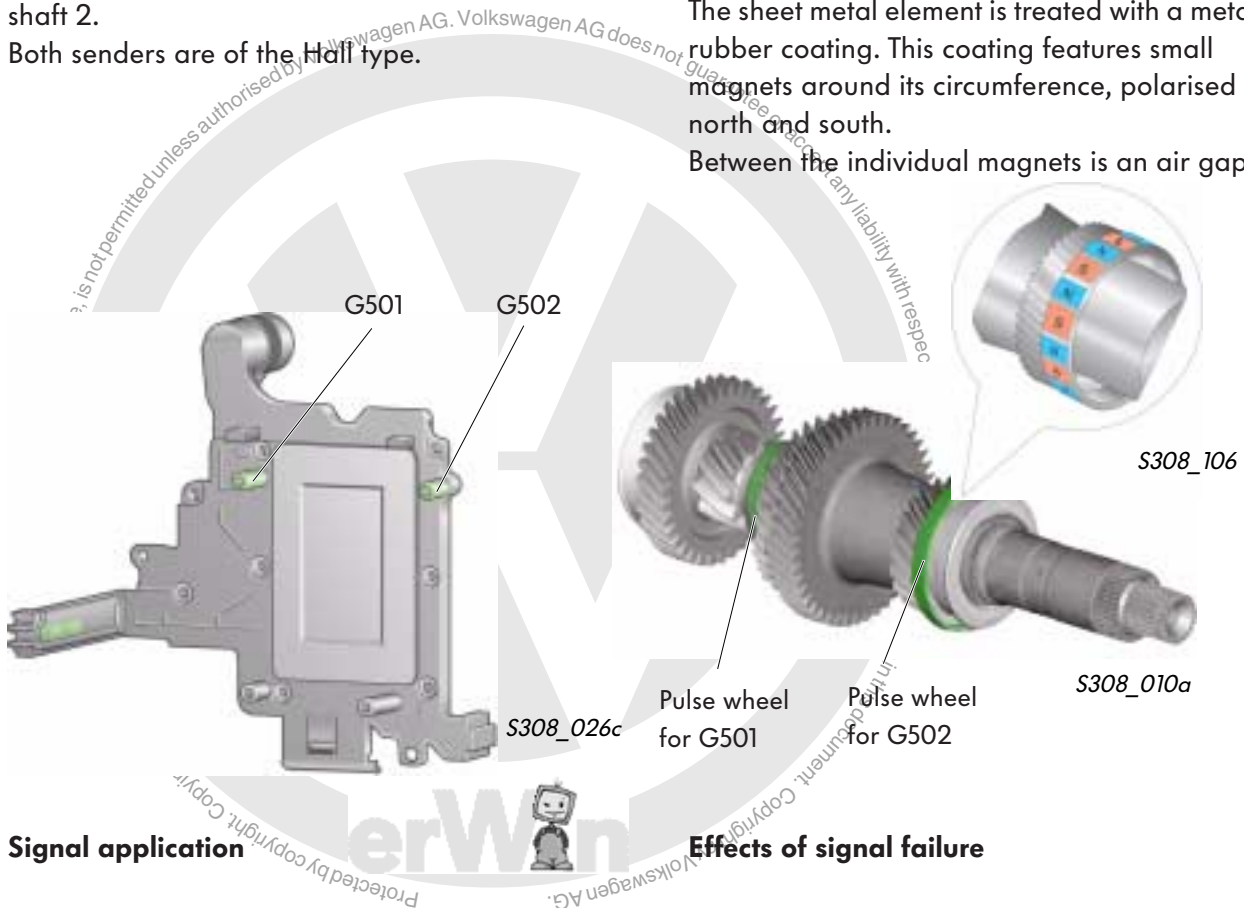

### Signal application

In conjunction with the gearbox input speed signal, the control unit determines the output speeds of the multi-plates clutches K1 and K2 and is therefore able to detect any slip.

Using this slip figure, the control unit can detect the open/close state of the clutches.

Furthermore, the signal is also used for control of the selected gear.

In conjunction with the gearbox output speed sender signals, the control unit detects whether the correct gear is selected.

### Effects of signal failure

If the event of signal failure, the affected gearbox section is isolated.

If sender G501 fails, the vehicle can only be driven in 2nd gear.

If sender G502 fails, the vehicle can only be driven in 1st and 3rd gear.



The pulse wheels should not be stored in the vicinity of powerful magnets.



# Sensors

## Gearbox output speed sender G195 and gearbox output speed sender 2 G196

Both senders can be found on the mechatronics and are joined permanently to the control unit. As with all speed senders in this gearbox, they are of the Hall sender type. They both scan the same pulse wheel on output shaft 2.

Both senders can be found opposed to each other in a housing. In this way, two signals offset against each other are created. If the signal from sender G195 is "high", the signal from sender G196 is "low".

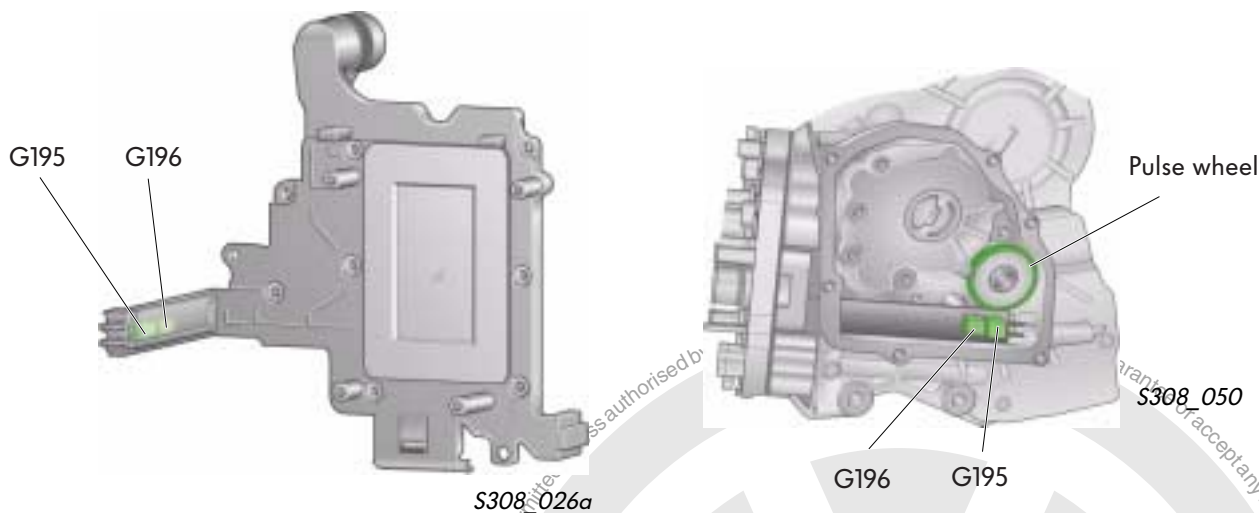

### Signal application

With the aid of these input signals, the control unit can detect the road speed and direction of travel.

The direction of travel is detected by the signals offset against each other.

If the direction of travel is changed, the signals reach the control unit in reverse order.

### Effects of signal failure

In the event of signal failure, the control unit uses the road speed and direction of travel signals from the ABS control unit.



## Hydraulic pressure sender 1 G193 and sender 2 G194

Both pressure senders can be found in the mechatronics electro-hydraulic control unit.

Sender 1 G193 is subjected to the same pressure as multi-plate clutch K1.

The pressure from multi-plate clutch K2 is imparted on sender 2 G194.

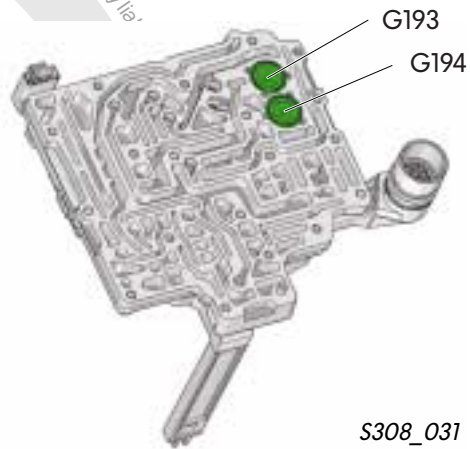

S308\_031

### Signal application

With the aid of these signals, the mechatronics control unit (ECU) detects the hydraulic pressure, which is imparted on the respective multi-plate clutch.

The exact hydraulic pressure is required by the control unit for regulation of the multi-plate clutch.

### Effects of signal failure

In the event of pressure signal failure or if no pressure is built up, the relevant gearbox section is isolated.

The vehicle can only be driven in 1st and 3rd or in 2nd gear.

### Function of pressure sender

The pressure sender comprises of a pair of electrically conductive plates in a sandwich construction. The upper plate is attached to a ceramic membrane, which bends in relation to the pressure change.

The other plate is force bonded to a ceramic base. This does not react to pressure changes.

As soon as the pressure changes, the upper membrane bends and the distance between the plates changes.

In this way, a reliable signal is generated based on the oil pressure.

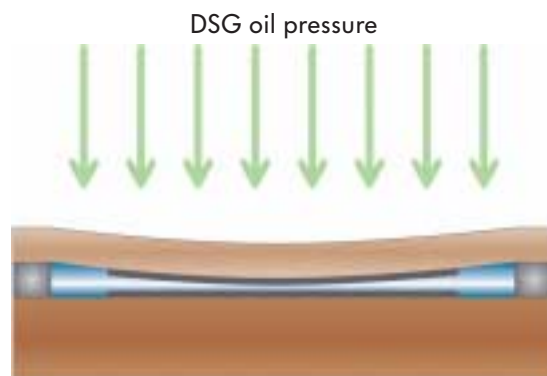
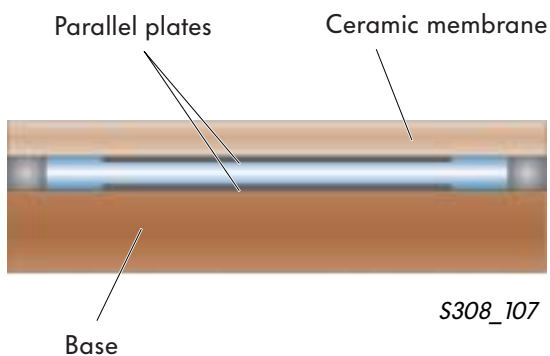

# Sensors

## Multi-plate clutch oil temperature sender G509

The sender G509 can be found in the housing of gearbox input speed sender G182.

It measures the temperature of the DSG oil at the outlet of the multi-plate clutches. Since the oil in the multi-plate clutches is placed under a large amount of thermal stress, oil reaches the highest temperature in the gearbox at this point.

This sender is designed to measure temperatures very quickly and very accurately.

It operates in a temperature range of  $-55\text{ }^{\circ}\text{C}$  to  $+180\text{ }^{\circ}\text{C}$ .

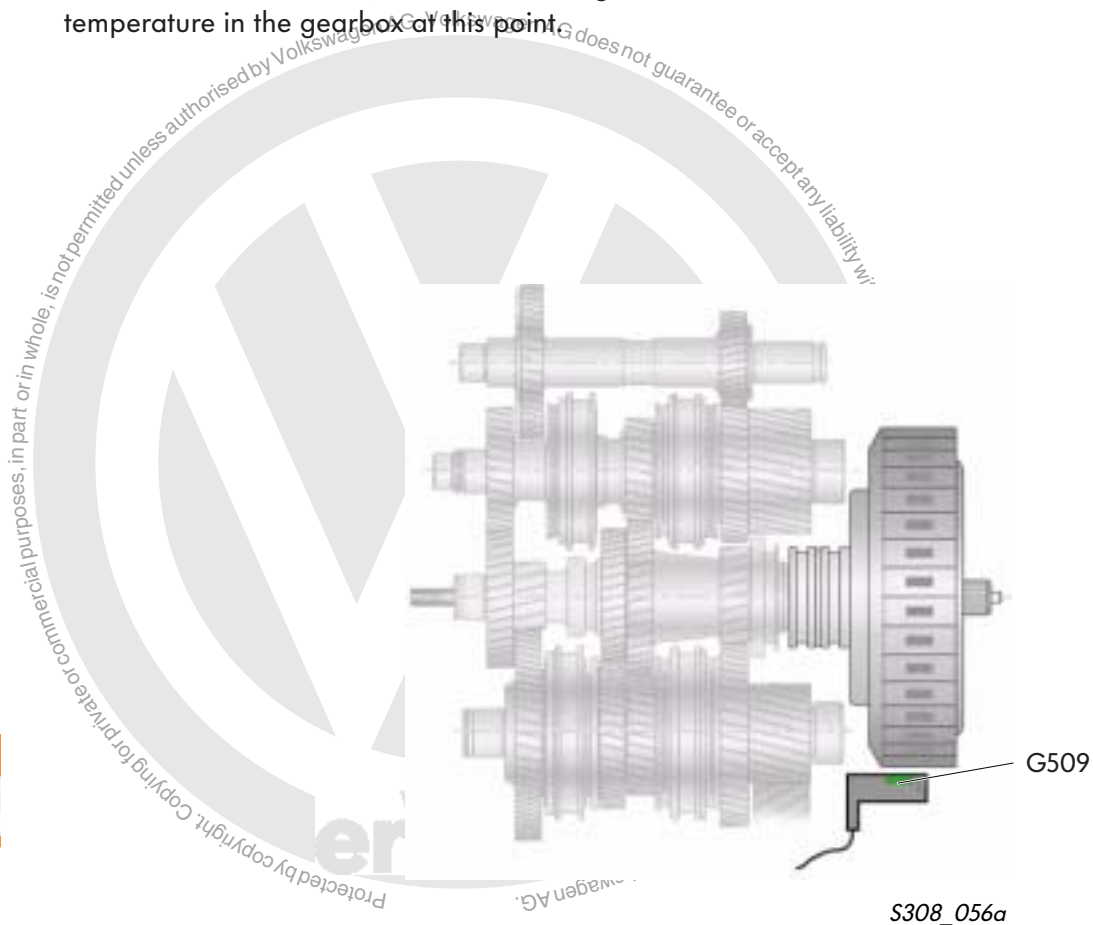

### Signal application

With the signals from temperature sensor G509, the control unit regulates the flow of clutch cooling oil and initiates further measures to protect the gearbox.

### Effects of signal failure

In the event of signal failure, the control unit uses the signals from senders G93 and G510 as a substitute value.

## Gear oil temperature sender G93 and control unit temperature sender G510

Both senders are located directly in the mechatronics.

The mechatronics are permanently surrounded in DSG oil and are heated in this way.

An excessive rise in temperature could impair the electronic functions.

Both senders measure the temperature directly in the components that are at risk. In this way, measures can be initiated to reduce oil temperature in good time to avoid excessive heat generation in the mechatronics.

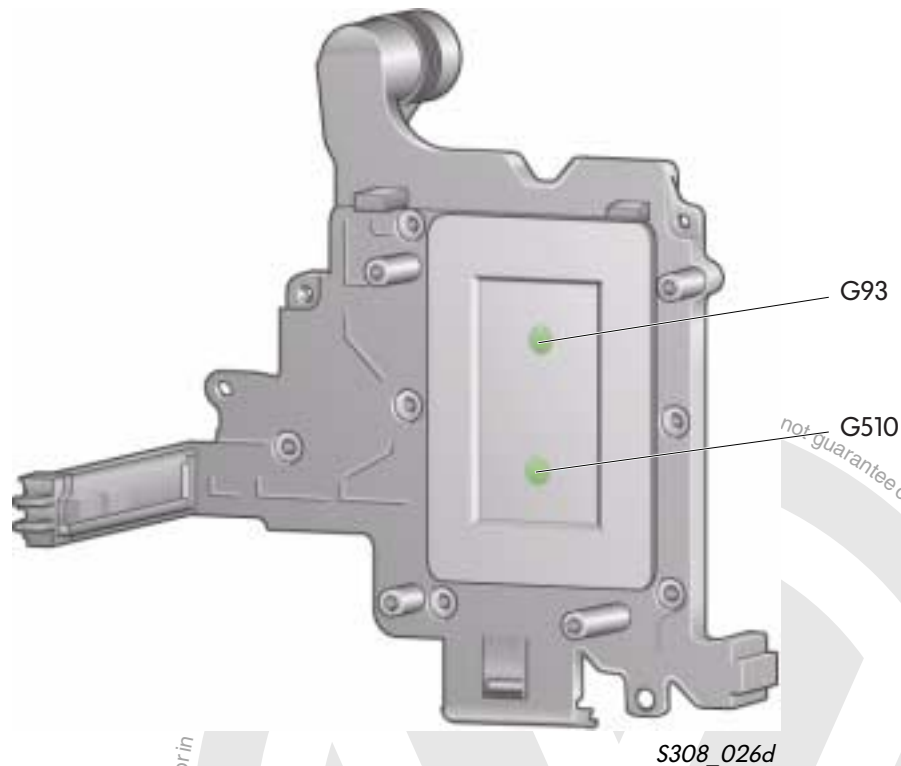

### Signal application

The signals from both senders are used to check the mechatronics temperature.

In addition, the sender signals are used to start a warm-up programme.

Both senders check each other for faults.

### Effects of signal failure

At gear oil temperatures in excess of 138 °C, the mechatronics initiate a reduction in engine torque.

At above 145 °C, oil is no longer supplied to the multi-plate clutches and they stay open.



# Sensors

## Travel sensors 1 to 4 G487, G488, G489, G490 for gear actuators

The travel sensors can be found in the mechatronics. They are of the Hall sender type. In conjunction with the magnets on the selector forks, they generate a signal which is used by the control unit to detect the position of the gear actuators.

Each travel sensor monitors the position of one gear actuator/selector fork, used to select between two gears

- G487 for 1st/3rd gears,
- G488 for 2nd/4th gears,
- G489 for 6th/reverse gears and
- G490 for 5th/neutral gears.

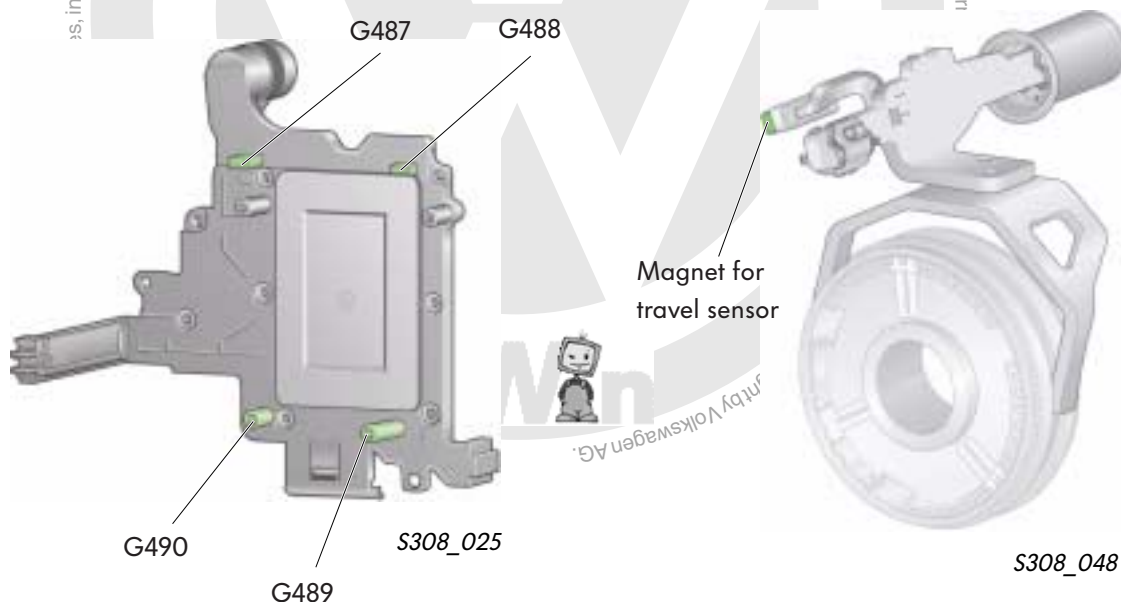

### Signal application

The control unit imparts oil pressure on the gear actuator for selection of the gears, based on the exact position.

### Effects of signal failure

If one travel sensor fails to send its signals, the affected gearbox section will be isolated. The gears of the affected gearbox section can no longer be engaged.

## Selector lever sensors control unit J587

The selector lever sensors control unit is integrated in the selector lever. It works as a control unit and as a sensor at the same time.

As a control unit it has the function of controlling the selector lever lock solenoids.

The selector lever lighting is integrated within.

Also located within are the Hall senders to detect the position of the selector lever and the Hall senders to detect Tiptronic operation.

The signals from the selector lever position and the signals from Tiptronic operation are sent via the CAN bus to the mechatronics and to the dash panel insert control unit.

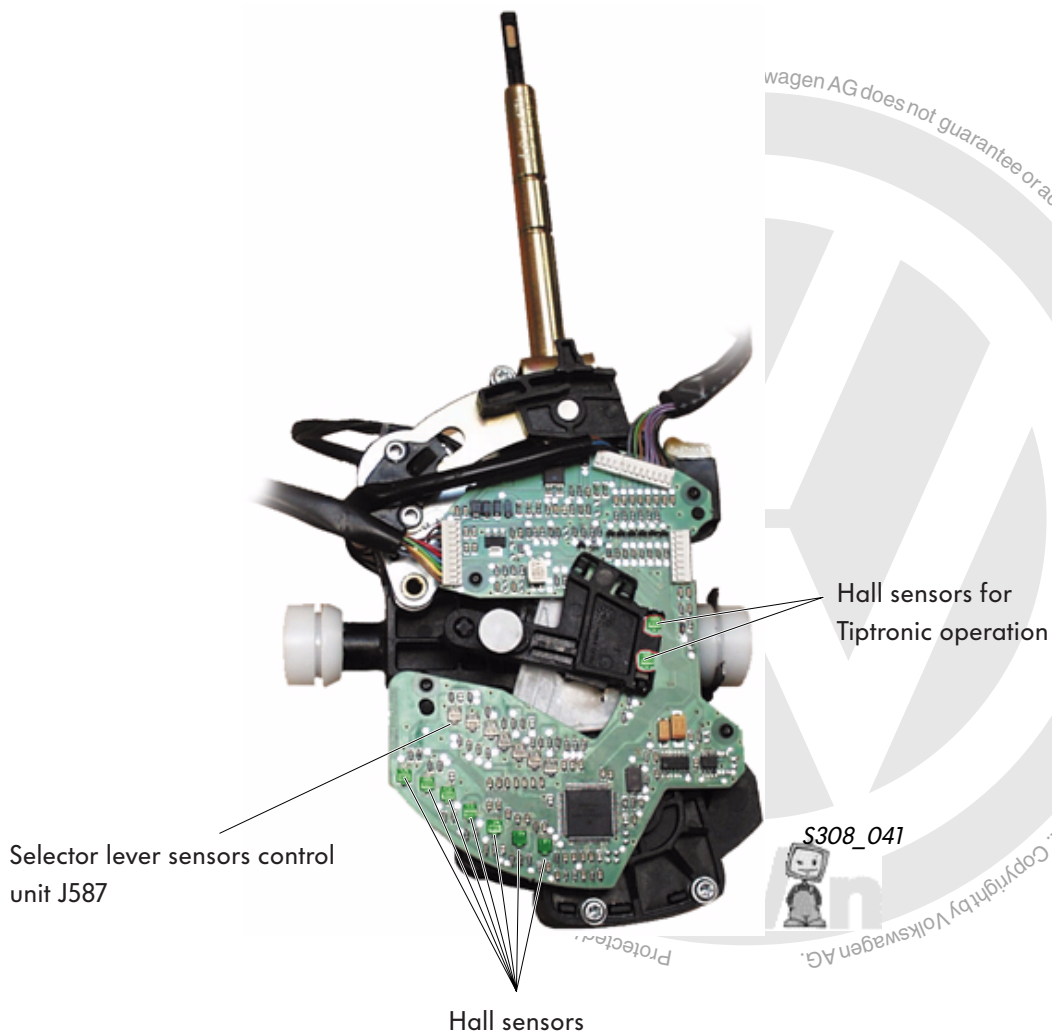

# Actuators

## Pressure control valve 3 N217 (main pressure valve)

Main pressure valve 3 can be found in the mechatronics electro-hydraulic control unit. It is a modulation valve.

The main pressure in the mechatronics hydraulic system is regulated by means of this valve. The most important factor for calculation of main pressure is the actual clutch pressure, which is dependent on engine torque.

The engine temperature and engine speed are used to correct the main pressure.

The control unit continually adapts the main pressure to the current operating conditions.

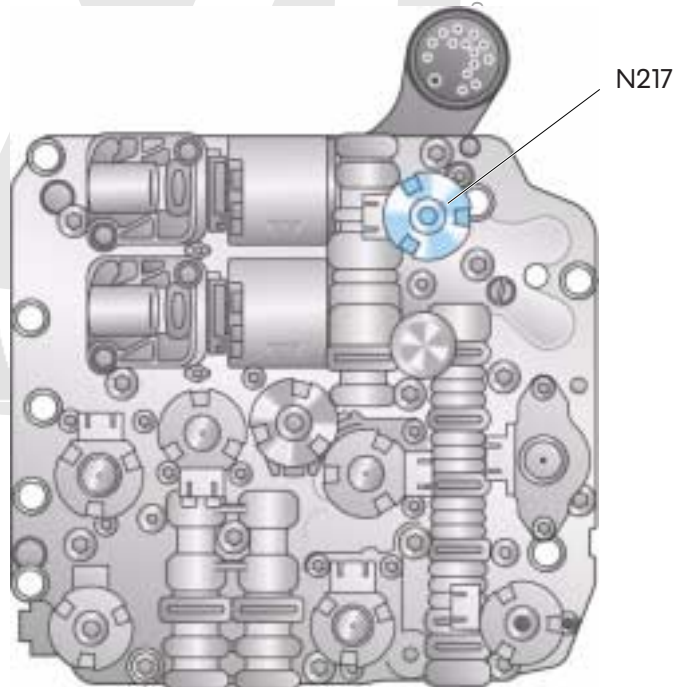

S308\_054\_1

## Effects of signal failure

In the event of pressure valve failure, the system works under maximum pressure.

This can lead to increased fuel consumption and gear selection noises.

## Pressure control valve 1 N215 and pressure control valve 2 N216 (clutch valves)

The pressure control valves N215 and N216 are located in the mechatronics electro-hydraulic control unit.

They are modulation valves and generate the control pressure for the multi-plate clutches – pressure control valve N215 controls multi-plate clutch K1 and pressure control valve N216 controls multi-plate clutch K2.

The basis for calculation of clutch pressure is the current engine torque.

The control unit adapts the clutch pressure to the current friction variable of the multi-plate clutches.

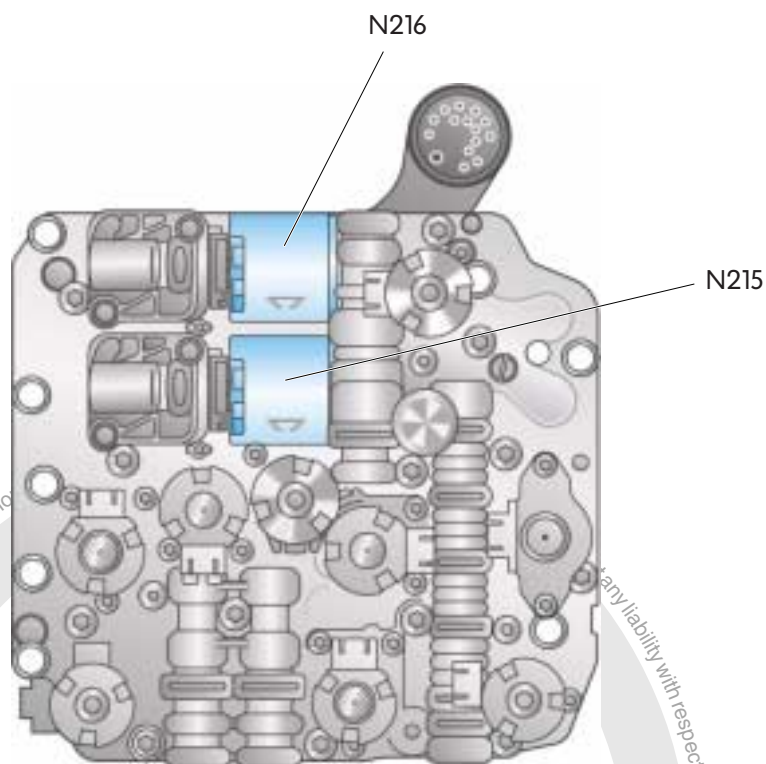

S308\_054\_4

### Effects of signal failure

In the event of pressure valve failure, the affected gearbox section is isolated. This fault will be displayed in the dash panel insert.



# Actuators

## Pressure control valve 4 N218 (cooling oil valve)

Pressure control valve N218 can be found in the electro-hydraulic control unit. It is a modulation valve and it controls the volume of cooling oil via an hydraulic slide valve.

The control unit uses the signal from the multi-plate clutch oil temperature sender G509 to control this valve.

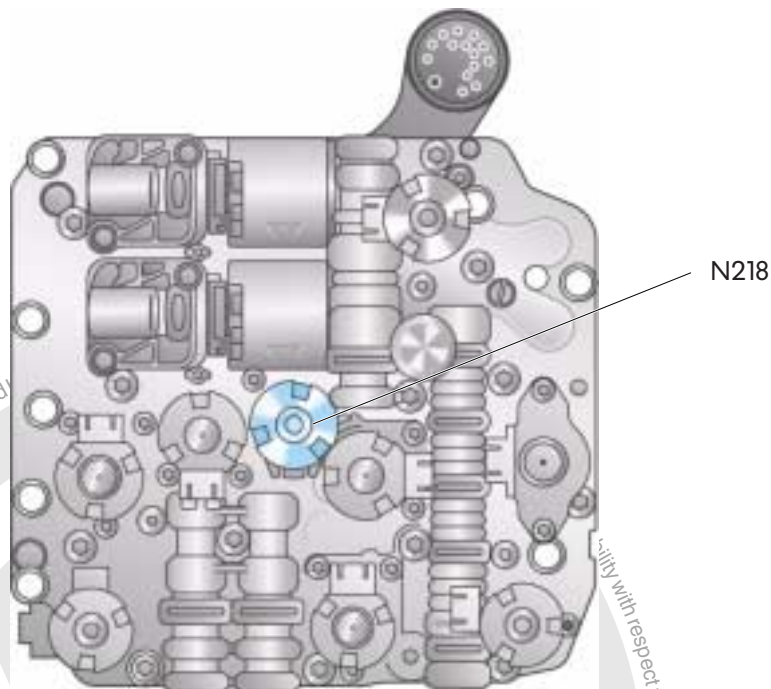

S308\_054\_2

### Effects of signal failure

If the pressure valve cannot be actuated, the maximum volume of cooling oil will flow through the multi-plate clutches.

This can result in gear change difficulties at cold ambient temperatures and excessive fuel consumption.



## Solenoid valves 1 N88, 2 N89, 3 N90 and 4 N91 (gear actuator valves)

All four solenoid valves can be found in the mechatronics electro-hydraulic control unit. They are "yes/no" valves.

They control the oil pressure to all gear actuators via the multiplexer slide valve.

The solenoid valves are in the closed position, unless energised, and oil pressure is thereby prevented from reaching the gear actuators.

Solenoid valve 1 N88 controls oil pressure to select 1st and 5th gear.

Solenoid valve 2 N89 controls oil pressure to select 3rd and neutral gear.

Solenoid valve 3 N90 controls oil pressure to select 2nd and 6th gear.

Solenoid valve 4 N91 controls oil pressure to select 4th and reverse gear.

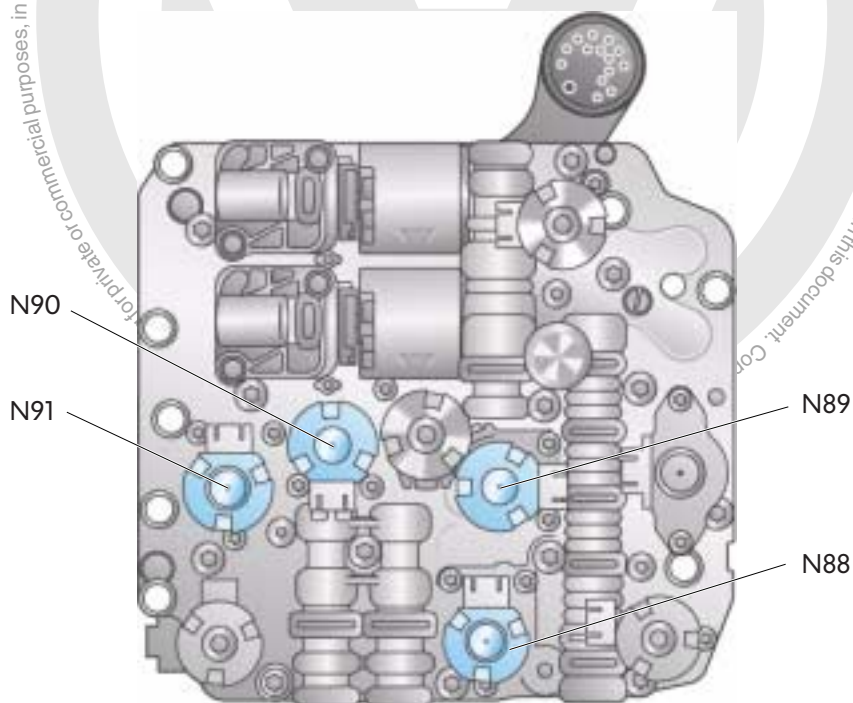

S308\_054\_13

### Effects of signal failure

In the event of solenoid valve failure, the relevant gearbox section, in which the gear actuator can be found, will be isolated.

The vehicle can only be driven in 1st and 3rd or in 2nd gear.



# Actuators

## Solenoid valve 5 N92 (multiplexer valve)

Solenoid valve 5 N92 can be found in the mechatronics electro-hydraulic control unit. It controls the multiplexer in the hydraulic control unit.

When the solenoid valve is activated, 2nd, 4th and 6th gears can be selected. When the solenoid is inactive, 1st, 3rd, 5th and reverse gears can be selected.

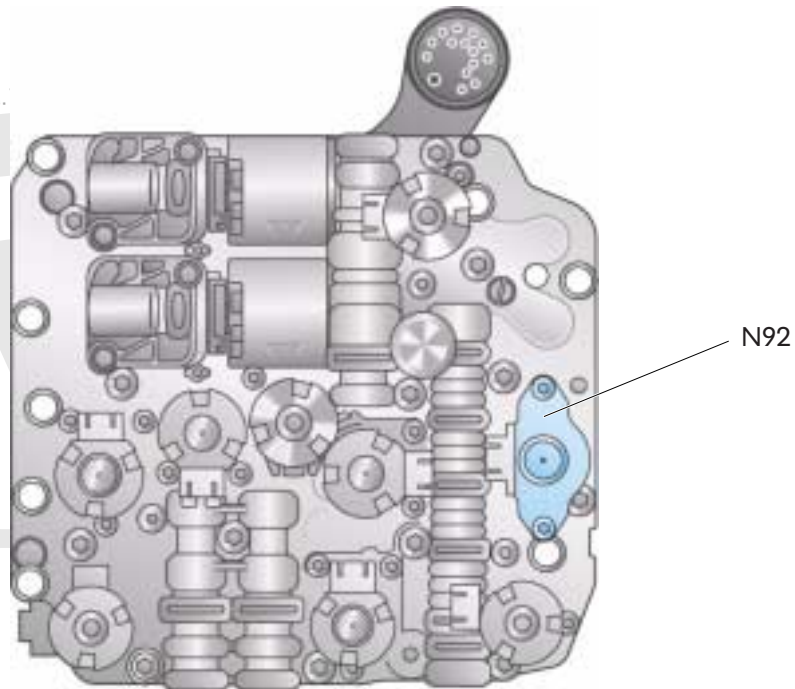

S308\_054\_11

### Effects of signal failure

The multiplexer valve will remain in the rest position. It can no longer be actuated by oil pressure. Incorrect gears could be selected. There is also a risk of the vehicle breaking down.

### Pressure control valve 5 N233 and pressure control valve 6 N371 (safety valves)

Pressure control valves N233 and N371 are housed in the mechatronics hydraulic module. They are modulation valves.

They control the safety slide valves in the mechatronics valve chest.

The safety slide valves isolate hydraulic pressure in the relevant gearbox section affected by the safety related fault.

Pressure control valve 5 N233 controls the safety slide valve for gearbox section 1.

Pressure control valve 6 N371 controls the safety slide valve for gearbox section 2.

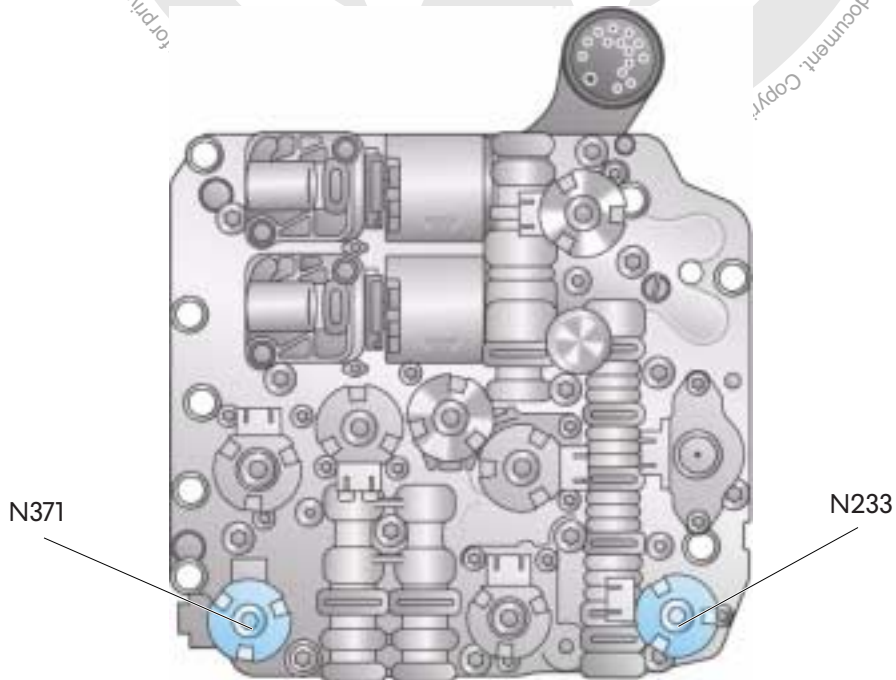

S308\_054\_6a

### Effects of signal failure

In the event of pressure control valve failure, gears can no longer be selected in the affected gearbox section.

If gearbox section 1 fails, the vehicle can only be driven in 2nd gear.

If gearbox section 2 fails, the vehicle can only be driven in 1st and 3rd gears.



# Functional diagram

Using Touran as example

## Components

- A - Battery
- E313 - Selector lever
- F4 - Reverse light switch
- F319 - Selector lever locked in position P switch
- G93 - Gear oil temperature sender
- G182 - Gearbox input speed sender
- G193 - Hydraulic pressure sender 1
- G194 - Hydraulic pressure sender 2
- G195 - Gearbox output speed sender 1
- G196 - Gearbox output speed sender 2
- G487 - Gear actuator travel sensor 1
- G488 - Gear actuator travel sensor 2
- G489 - Gear actuator travel sensor 3
- G490 - Gear actuator travel sensor 4
- G501 - Speed sender for input shaft 1
- G502 - Speed sender for input shaft 2
- G509 - Multi-plate clutch oil temperature sender
- G510 - Control unit temperature sender
- J... - Engine control unit
- J329 - Terminal 15 voltage supply relay
- J519 - Onboard supply control unit
- J527 - Steering column electronics control unit
- J587 - Selector lever sensors control unit
- J743 - Direct shift gearbox mechatronics
- N88 - Solenoid valve 1
- N89 - Solenoid valve 2
- N90 - Solenoid valve 3
- N91 - Solenoid valve 4
- N92 - Solenoid valve 5
- N110 - Selector lever lock solenoid
- N215 - Pressure control valve 1 for automatic gearbox
- N216 - Pressure control valve 2 for automatic gearbox
- N217 - Pressure control valve 3 for automatic gearbox
- N218 - Pressure control valve 4 for automatic gearbox
- N233 - Pressure control valve 5 for automatic gearbox
- N371 - Pressure control valve 6 for automatic gearbox

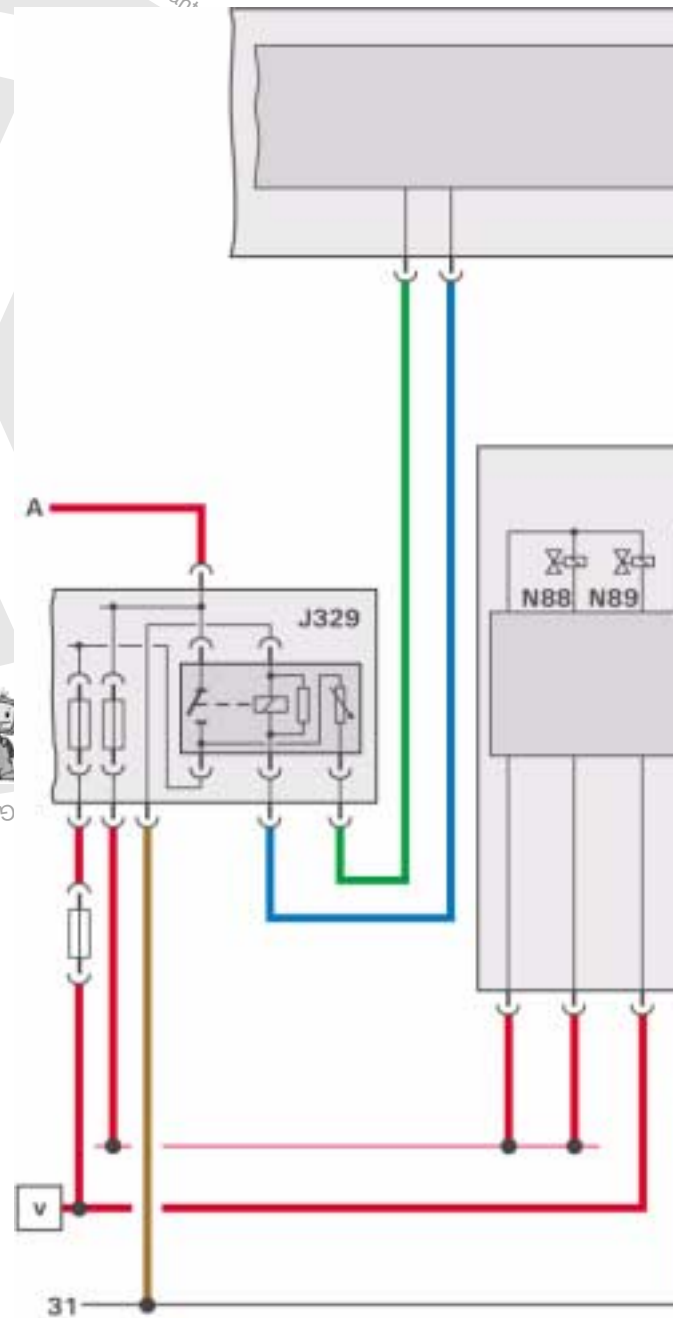

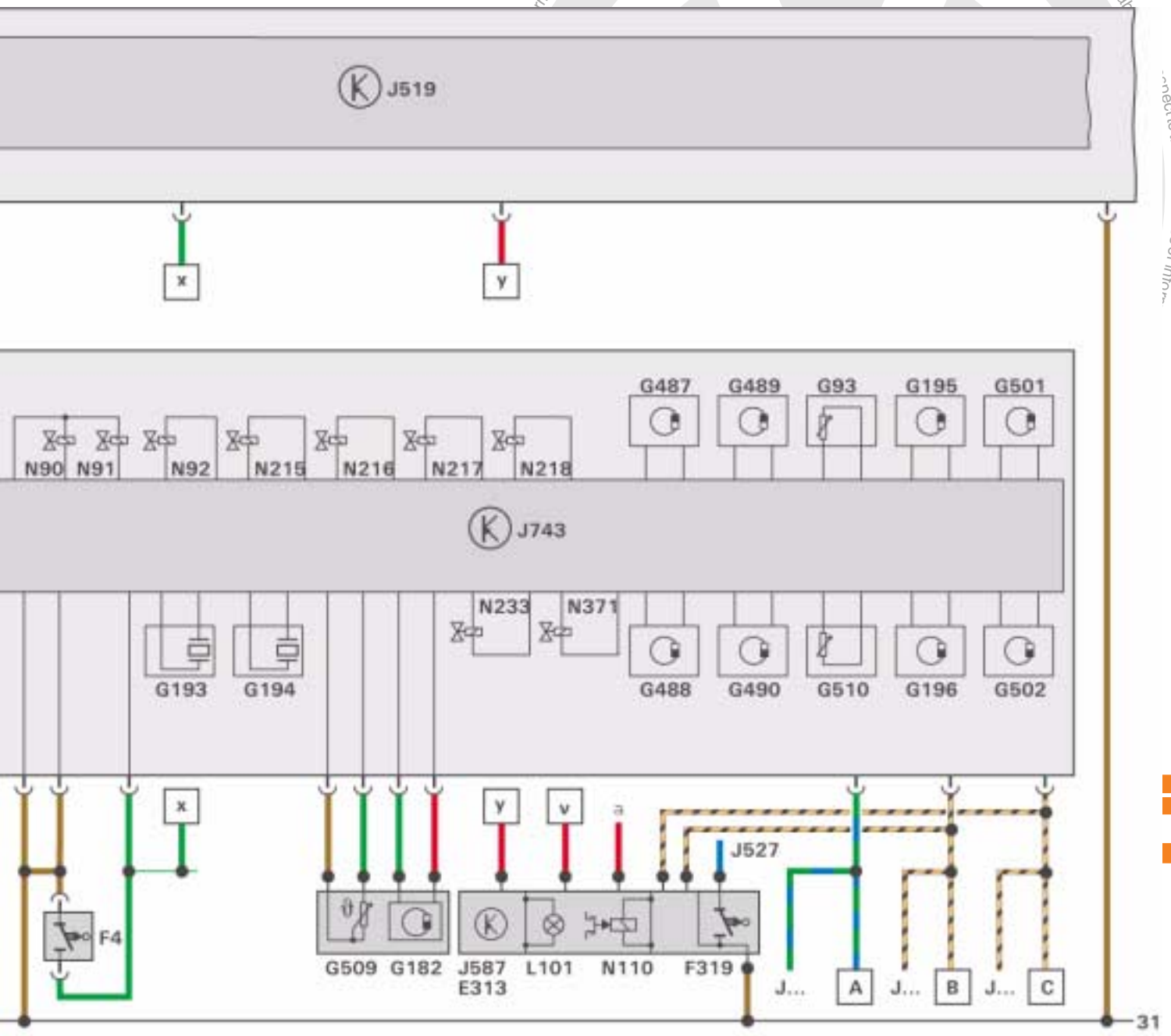

...ect to the correctness of Informa-



S308\_100

- a - Term. 30 via fuse SC21
- A - COM lead
- B - CAN drive high
- C - CAN drive low

# CAN data bus connection

## CAN data bus connection

The diagram shown below is a figurative representation of how the direct shift gearbox mechatronics are connected to the CAN data bus structure of the vehicle.

J104 - ABS with EDL control unit

J248 - Diesel direct injection control unit

J285 - Control unit with display in dash panel insert

J519 - Onboard supply control unit

J527 - Steering column electronics control unit

J533 - Data bus diagnostic interface

J587 - Selector lever sensors control unit

J623 - Engine control unit

J743 - Direct shift gearbox mechatronics

Developed by Volkswagen AG. Volkswagen AG does not guarantee

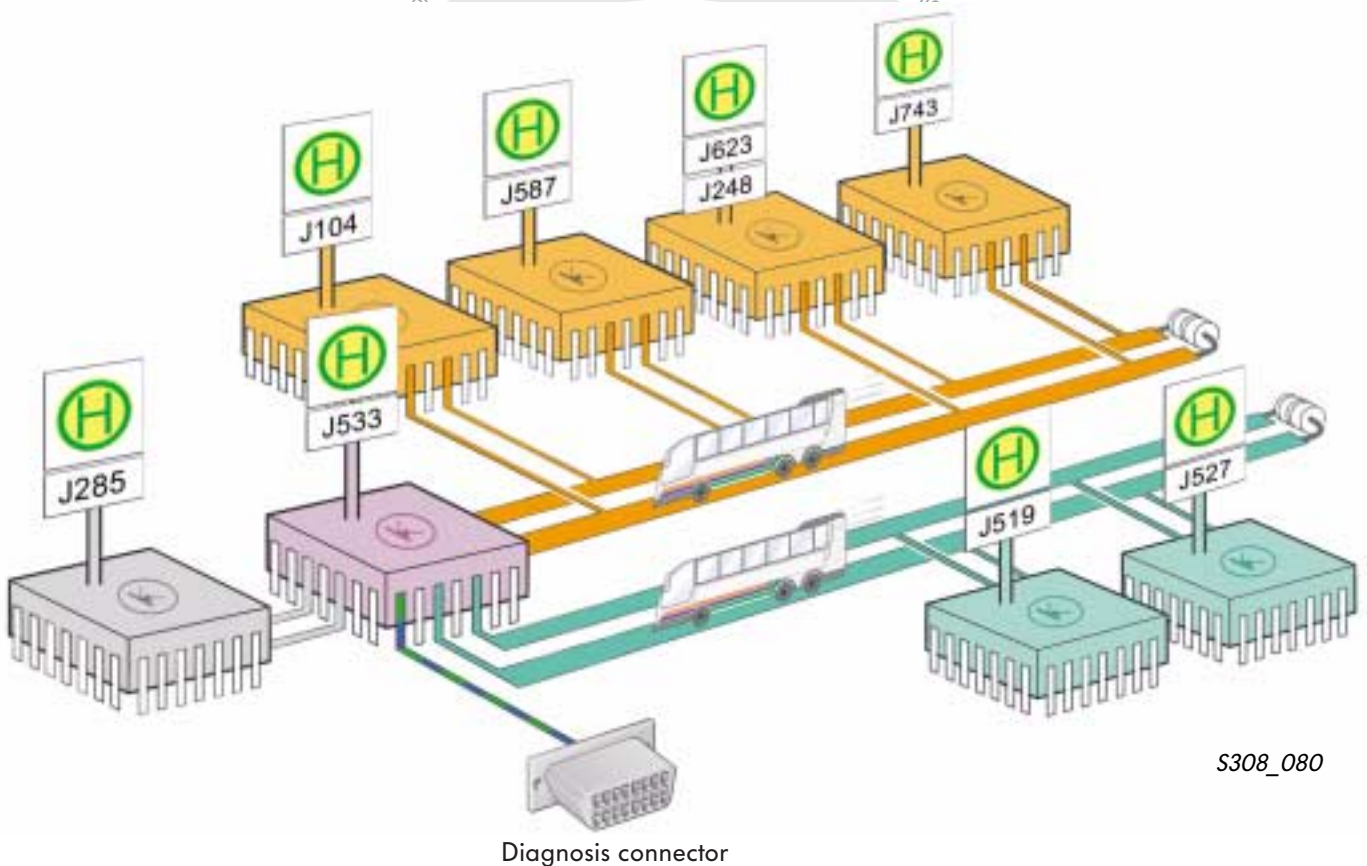

S308\_080

 CAN data bus "drive"

 CAN data bus "comfort"

## Diagnosis

On vehicle diagnosis, testing and information system VAS 5051, the following modes of operation:

- Guided fault finding
- Guided functions

can be chosen.

### Operating mode "Guided fault finding"

In "Guided fault finding" mode, a test schedule is available for the direct shift gearbox, with which the following sensors, actuators and mechatronics can be tested in operation.

Please refer to the instructions on VAS 5051 when testing sensors and actuators.

Sensors:

- G93 - Gear oil temperature sender
- G182 - Gearbox input speed sender
- G193 - Hydraulic pressure sender 1
- G194 - Hydraulic pressure sender 2
- G195 - Gearbox output speed sender 1
- G196 - Gearbox output speed sender 2
- G487 - Gear actuator travel sensor 1
- G488 - Gear actuator travel sensor 2
- G489 - Gear actuator travel sensor 3
- G490 - Gear actuator travel sensor 4
- G501 - Speed sender for input shaft 1
- G502 - Speed sender for input shaft 2
- G509 - Multi-plate clutch oil temperature sender
- G510 - Control unit temperature sender

Actuators:

- N88 - Solenoid valve 1
- N89 - Solenoid valve 2
- N90 - Solenoid valve 3
- N91 - Solenoid valve 4
- N92 - Solenoid valve 5
- N110 - Selector lever lock solenoid
- N215 - Pressure control valve 1
- N216 - Pressure control valve 2
- N217 - Pressure control valve 3
- N218 - Pressure control valve 4
- N233 - Pressure control valve 5
- N371 - Pressure control valve 6

Mechatronics:

Mechatronics fault

- J743 - Mechatronics gear monitoring
- J743 - Mechatronics selection monitoring
- J743 - Mechatronics power supply

### Operating mode "Guided functions"

In "Guided functions" mode, a test schedule is available for the direct shift gearbox, with which the oil level can be checked.



# Service

## Special tools

To replenish and check the DSG oil, use new special tool VAS 6252.

The quick acting coupling of the special tool allows the oil level to be checked without the user having to unscrew the adapter out of the gearbox.

The three-way tap of the oil flange connection makes it possible to change oil bottles without trouble.



S308\_110

Protected by copyright. Copying for private or commercial purposes, in part or in whole, is not permitted unless authorized by Volkswagen AG. Volkswagen AG does not guarantee or accept any liability for the use of this document. Copyright by Volkswagen AG.



## Which answers are correct?

One or more or all answers could be correct.

### 1. The double clutch gearbox allows

- a) jolt-free selection of gears without interruption in pulling power.
- b) the vehicle to be driven like an automatic.
- c) the transmission of torque to be doubled.

### 2. The oil lubrication circuit is responsible for

- a) lubrication of the gear wheels.
- b) actuation of the clutch.
- c) cooling of the multi-plate clutches.

### 3. Which gears are engaged via multi-plate clutch K1?

- a) 1st, 3rd, 5th and reverse
- b) 2nd, 4th and 6th
- c) all gears

### 4. To which component does output shaft 1 transmit torque?

- a) to the differential
- b) to output shaft 2
- c) to the oil pump

### 5. By which components are the locking collars actuated for gear selection?

- a) The selector lever
- b) The selector forks
- c) The selector lever cable



# Test yourself

## 6. Which gears are equipped with three-fold synchronisation?

- a) 4th gear
- b) 1st, 2nd and 3rd gear
- c) Reverse gear

## 7. What is the selector lever cable responsible for?

- a) It informs the control unit about the selector lever position.
- b) It actuates the parking lock.
- c) The DSG does not need a selector lever cable.

## 8. How many temperature sensors are there in the DSG?

- a) One sensor
- b) Two sensors
- c) Three sensors

## 9. What are the effects of failure in gear actuator travel sensor G488?

- a) The gearbox section for 2nd, 4th and 6th gear is isolated.
- b) The vehicle can only be driven in 1st and 3rd gears.
- c) No effects on gear selection.

**10. Where are the DSG mechatronics located?**

- a) In the plenum chamber
- b) In the front passenger's footwell
- c) The mechatronics are integrated in the gearbox.

**11. In which gear can the vehicle still be driven if gearbox section 1 is isolated?**

- a) In 1st gear
- b) In 2nd gear
- c) In 3rd gear

**12. Which information is provided to the mechatronics by senders G195 and G196?**

- a) Direction of travel
- b) Input speed
- c) Road speed

**13. The oil pump is driven**

- a) by its own pump shaft
- b) by input shaft 1
- c) electrically



1. a, b; 2. a, b, c; 3. a; 4. a; 5. b; 6. b; 7. b; 8. c; 9. a, b; 10. c; 11. b; 12. a, c; 13. a

**Answers:**





© VOLKSWAGEN AG, Wolfsburg, VK-36 Service Training  
All rights and the right to make technical alterations reserved  
000.2811.29.20 Technical status 10/03

♻️ This paper was manufactured from pulp that was bleached without the use of chlorine.