

Service.



Self-Study Programme 299

The 6-Speed Manual Gearbox 08D

Design and Function



The Touareg is an exclusive cross country vehicle with the driving properties and driving comfort of a sporty luxury class automobile. That means that an extremely high level of flexibility has been realised for various driving conditions.

Every driving situation, such as pulling away, hill starting, off-road driving, motorway or highway cruising and reversing, requires the correct amount of torque, speed and direction.

For the optimal transmission of engine force to the driving wheels in any driving situation, the Touareg off-roader is also available with a 6-speed manual gearbox. The 6-speed manual gearbox 08D was developed especially for the operating conditions of this vehicle.



S299_021

NEW



Important Note



This Self-Study Programme explains the design and function of new developments. The contents will not be updated.

For current inspection, adjustment and repair instructions, please refer to the relevant service literature.

Contents



Introduction4

Gearbox mechanics 6

Gear selection18

Sensors34

Service35

Test yourself 40



Introduction



For power transmission, the Touareg can be fitted with a 6-speed manual gearbox.

The newly developed 6-speed manual gearbox offers this vehicle a compact gear ratio configuration (short gear changes) with powerful torque transmission in cross country conditions and sporty operation for the road.



S299_015

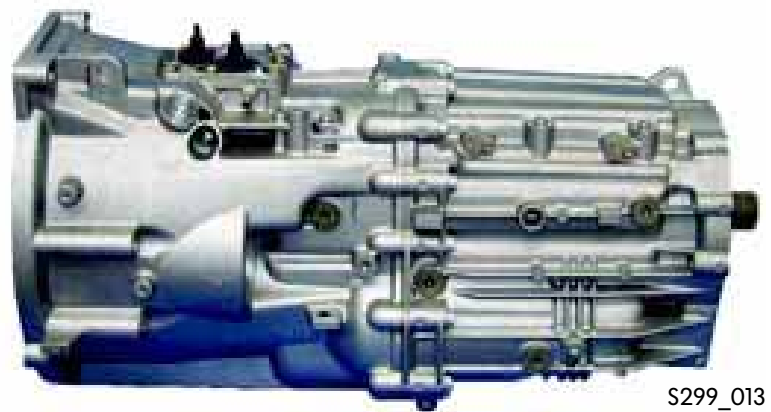

S299_013



S299_019

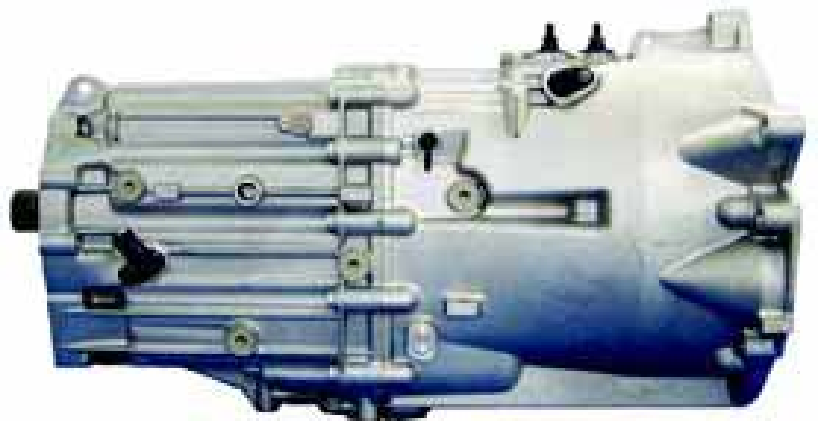

S299_017



Technical data

- Installation position: Longitudinal
- Gear oil capacity: 1.8 ltr. "lifetime" oil
- Total weight: 60 kg with oil
- Gear oil specification: Synthetic oil

Transmission ratio overview

The 6-speed manual gearbox 08D can be combined with the following engines:

Gear	VR6			R5 TDI		
	Constant-mesh	Tooth pair	Ratio	Constant-mesh	Tooth pair	Ratio
1	41:31	46:13	4.68	44:27	46:13	5.766
2	41:31	44:23	2.53	44:27	37:20	3.015
3	41:31	37:31	1.579	44:27	33:29	1.854
4	41:31	34:37	1.215	44:27	29:36	1.313
5			1			1
6	41:31	31:49	0.837	44:27	26:53	0.799
Reverse	41:31	(23:13)x(42:23)	4.273	44:27	(23:13)x(42:23)	5.265

Gearbox mechanics

The gearbox design

The 6-speed manual gearbox 08D is a longitudinal transmission unit with fully synchronised gears.

It features an input shaft, a layshaft and an output shaft.

All selector gears have needle roller bearings and can be found on the layshaft and output shaft.

The 5th gear is selected directly.

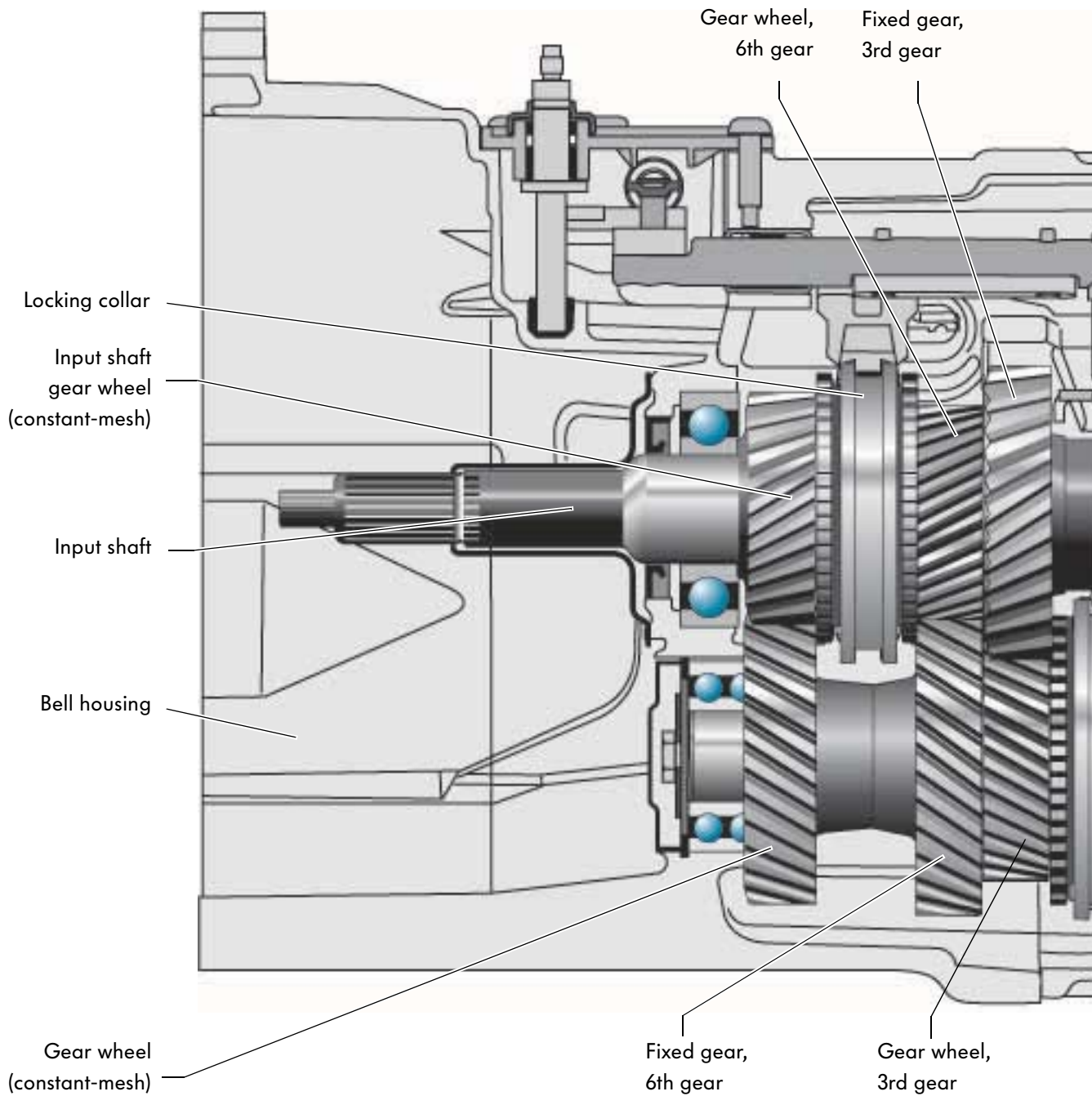

Selection of the gears is done by radial and axial movement of a central selector shaft with selector fingers that engage in the respective forks.

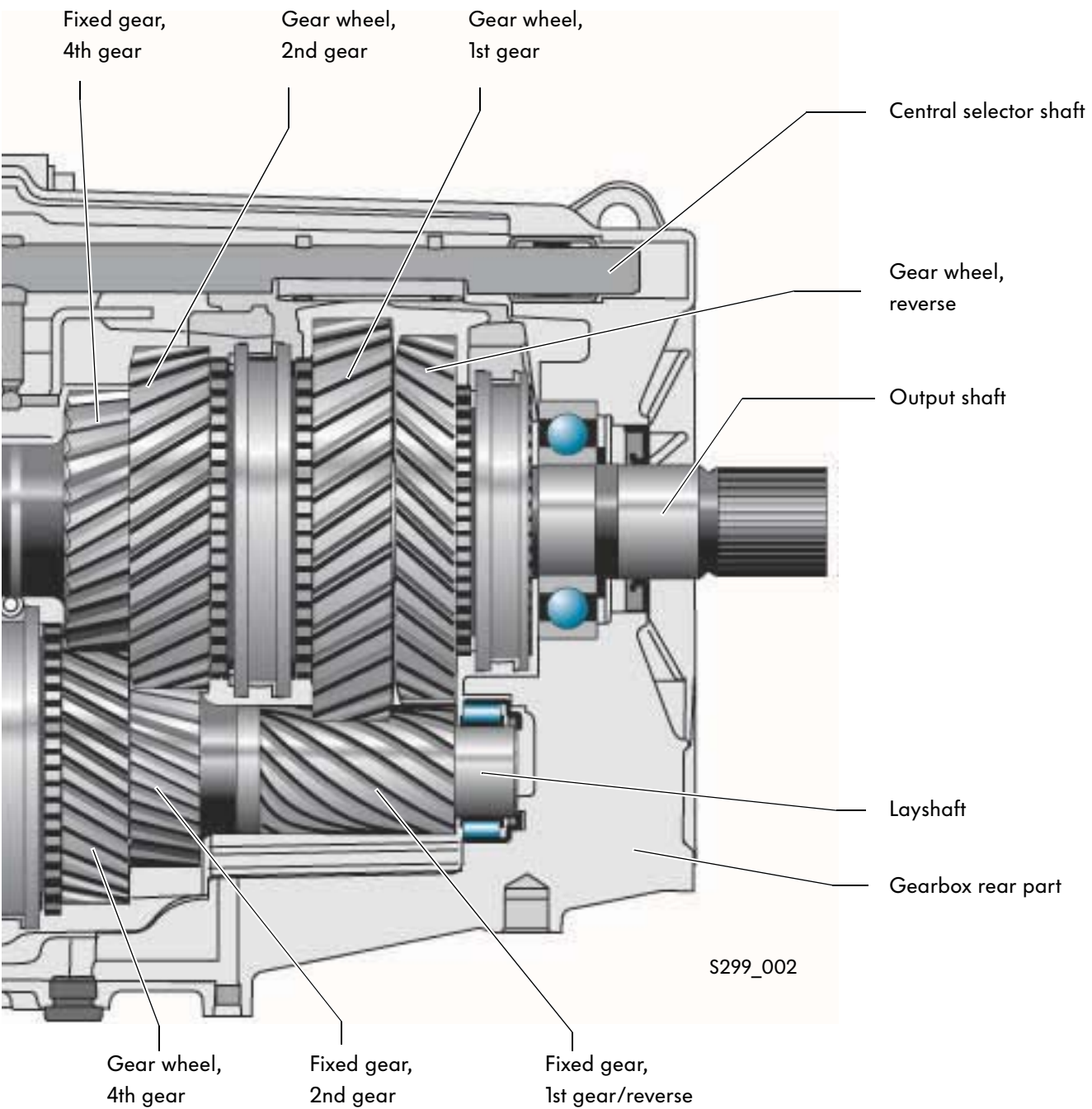

S299_002

Gearbox mechanics

The transmission housing

is made from aluminium and consists of 2 parts, the bell housing and the gearbox rear part.

The flange pattern of the bell housing will differ depending on the type of engine installed.

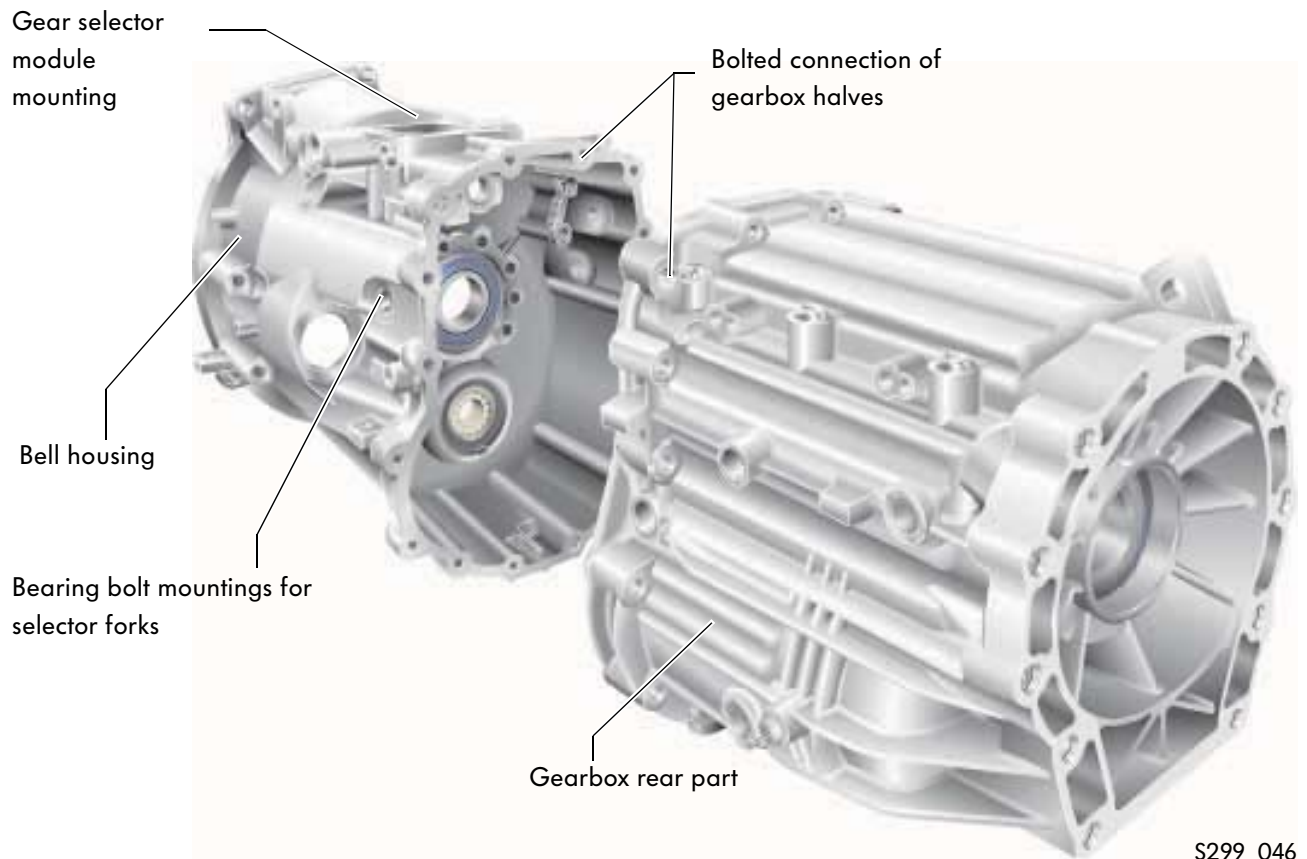

S299_046

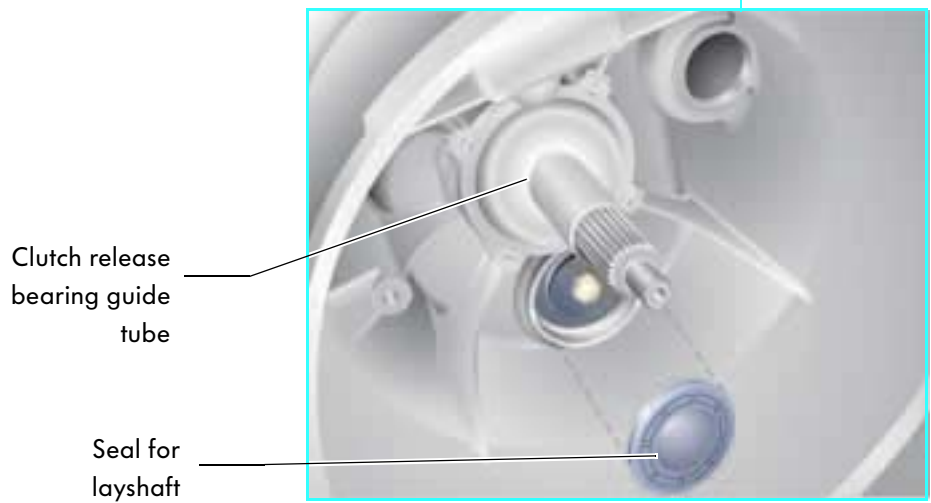
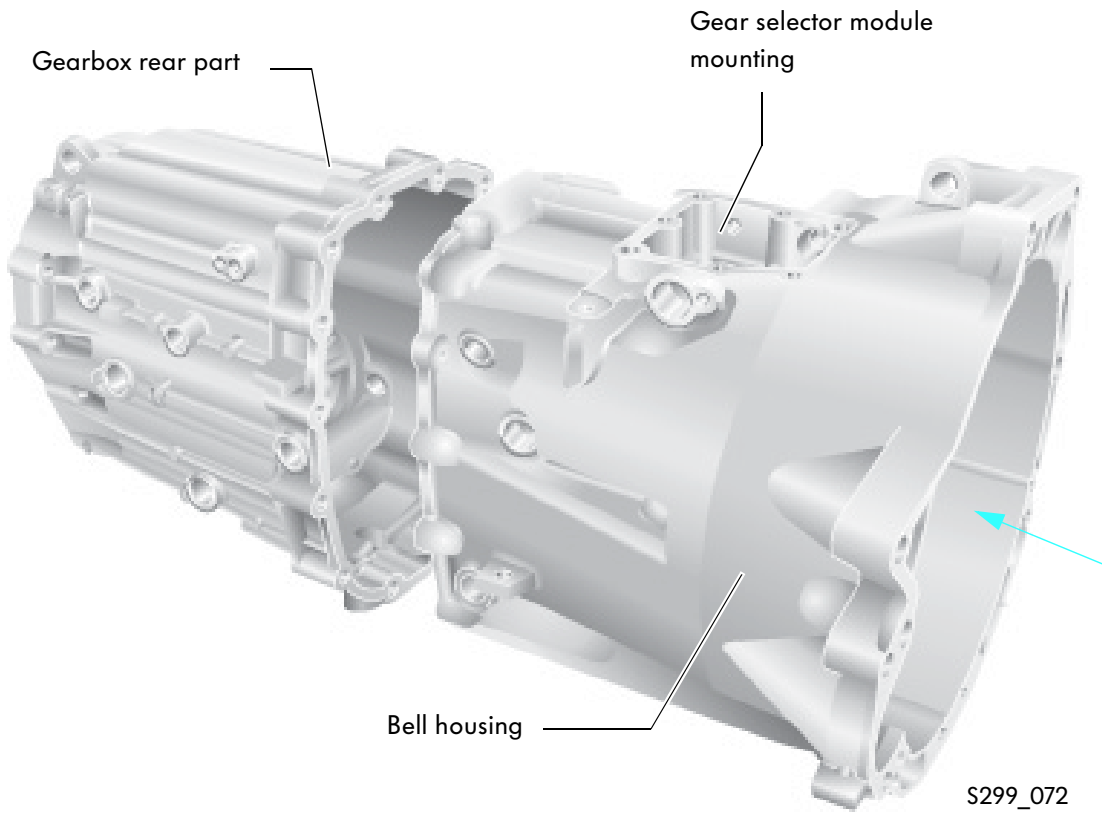

Gearbox mechanics

The input shaft

The input shaft has a fixed mounting in the bell housing in the form of a grooved ball bearing.

A roller bearing serves as a radial bearing between the input and output shafts. It can be found in the hole for the input shaft.

The input shaft gear wheel for the constant level is joined to the input shaft.

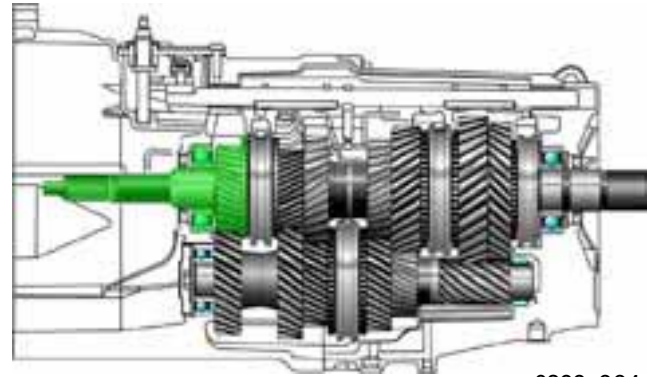

S299_004

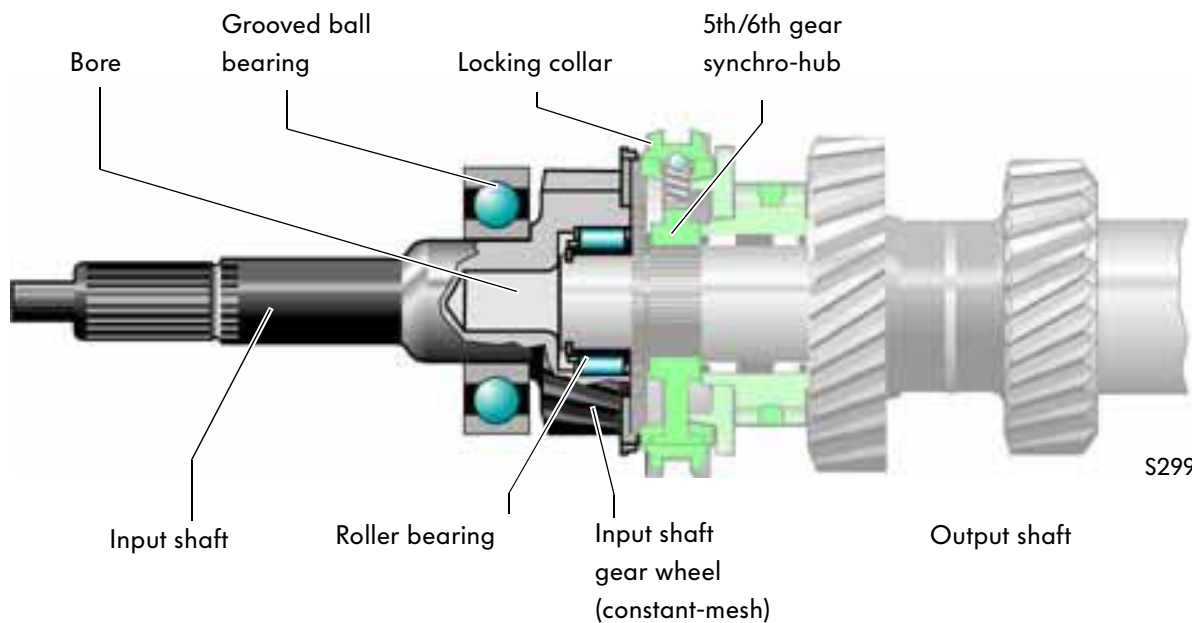

S299_006

The output shaft

The fixed bearing of the output shaft is a grooved ball bearing that can be found in the gearbox rear part. A roller bearing serves as a radial bearing between the input and output shaft.

The fixed gear wheels of the 3rd and 4th gears are joined to the output shaft. The selector gears for 1st, 2nd, 6th and reverse can be rotated and feature needle roller bearings. They are referred to as idler gears. The selector gears are constantly in rotation with the respective fixed gear wheels. Not until a gear is selected are they connected with the output shaft, by means of a locking collar, and thereby capable of transmitting torque.

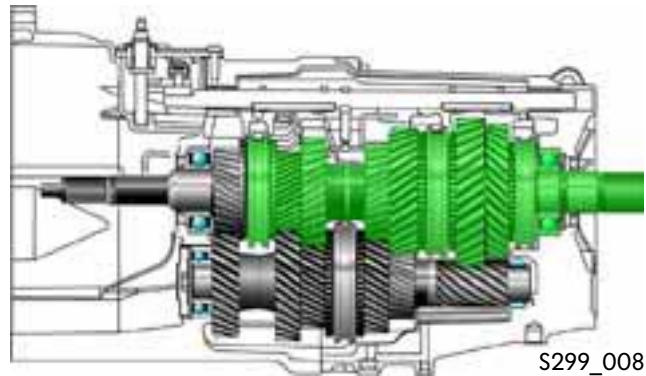

The synchro-hubs of the 1st/2nd gear, the 5th/6th gear and reverse are connected to the output shaft by means of gear teeth.

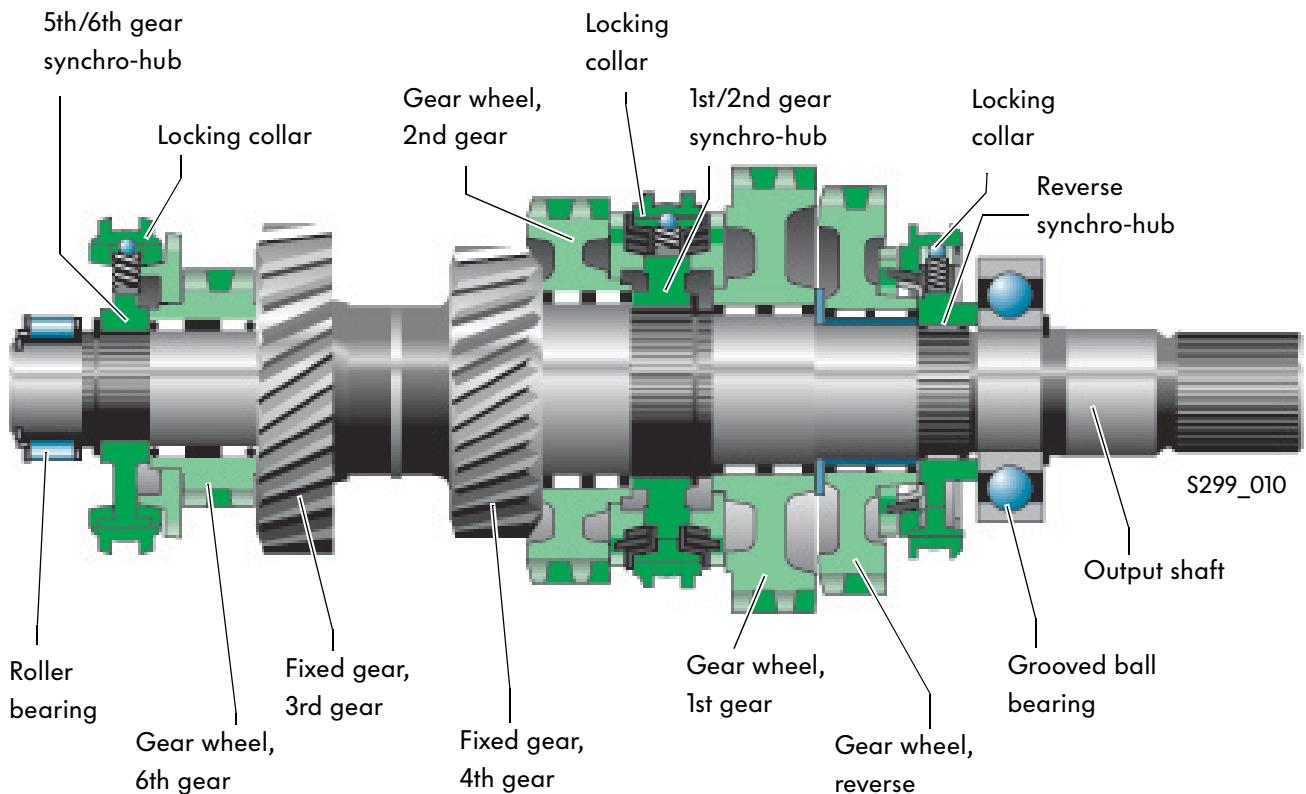

Gearbox mechanics

The layshaft

The layshaft bearings are also fixed and radial.

The double grooved roller bearing can be found in the bell housing and the roller bearing can be found in the gearbox rear part.

The fixed gear wheels of the 1st and 2nd gears are joined to the layshaft.

The selector gears for 3rd and 4th gear are idler gears

and have needle roller bearings. The selector gear for 6th gear and the constant-mesh gear are joined to the layshaft by means of gear teeth. They are referred to as fixed gears.

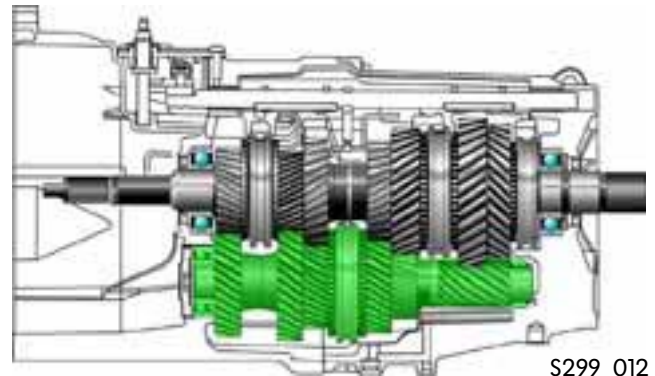

The synchro-hub of the 3rd/4th gear is also fixed on the layshaft by means of gear teeth.

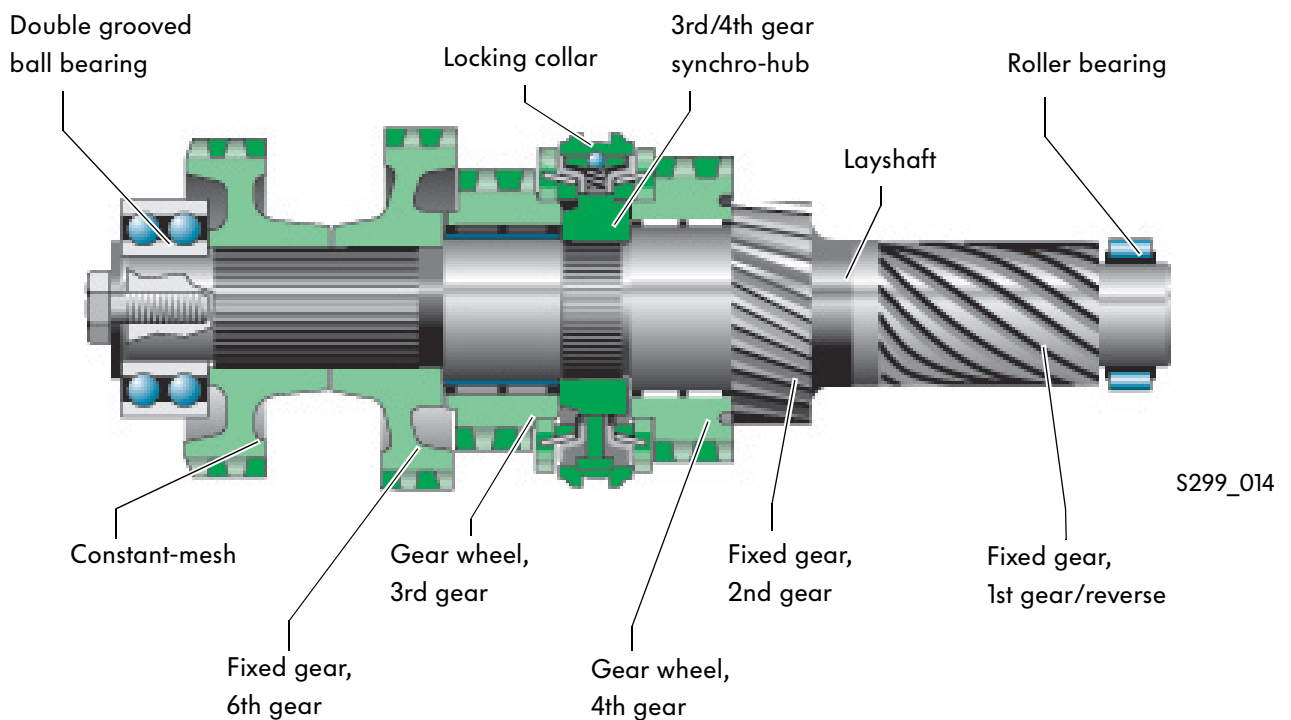

The synchronisation

Before a gear can be selected, the speed of the selector gear must be synchronised with that of the synchro-hub. To increase the frictional resistance for synchronisation and thereby reduce the force required to select a gear, 3-cone synchronisation takes place when 1st/2nd gear is selected. For 3rd/4th gear and reverse, double cone synchronisation takes place. The 5th/6th gear is synchronised by a friction cone.



3-cone synchronisation

The package for 3-cone synchronisation consists of:

- an outer ring (synchro-ring)
- a spacer ring
- an inner ring
- and a friction cone on the respective selector gear.

Via cams on the synchro-rings, the synchro-hub is connected to the outer and inner ring. They move with the rotating speed of the output shaft. The spacer ring is connected to the selector gear and rotates at the same speed as the selector gear.

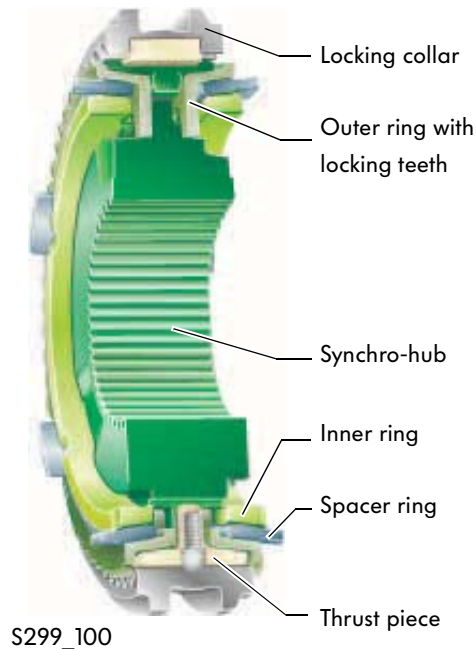

Gearbox mechanics

The function of 3-cone synchronisation

The synchronisation of speed between locking collar and selector gear is done by 3-cone synchronisation during gear selection of the first or second gear by means of frictional resistance.

The locking teeth will only allow complete gear selection once the locking collar is synchronised with the respective selector gear.

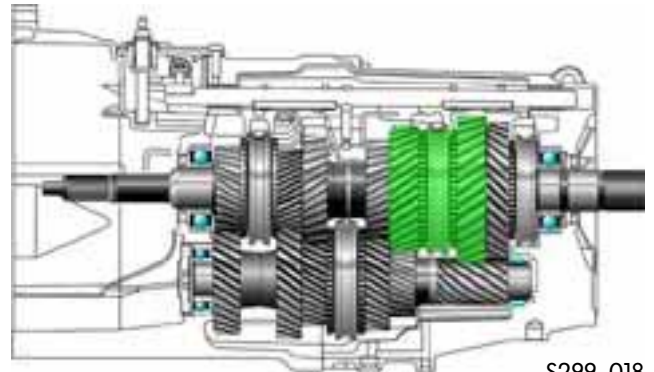

S299_018

- Idle position

At idling speed, the locking collar and the synchro package rings are in neutral. None of the selector gears are connected to the output shaft. There is no power transmission.

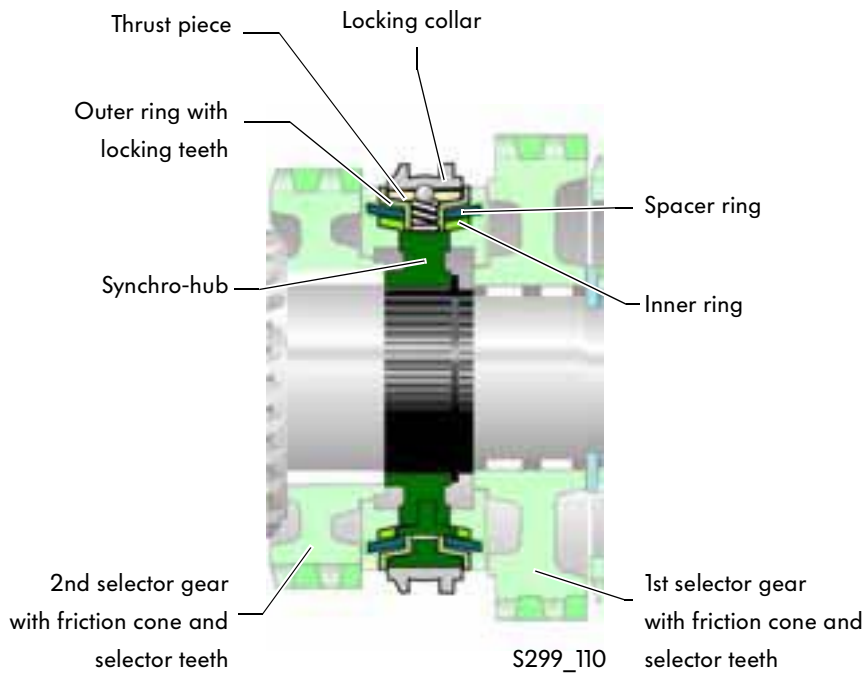

S299_110

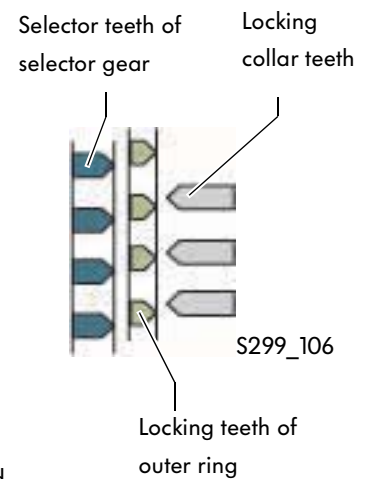

S299_106

- Synchronisation process



S299_110

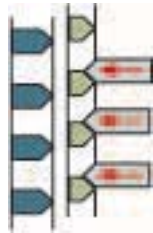

S299_108

The locking collar is moved in the direction of the selector gear by the 1st/2nd gear selector fork. During this motion, the thrust pieces are forced axially against the synchro-package. The friction surfaces of the individual rings and the friction cone of the selector gear are moved into position and synchronisation of the various speeds between the output shaft and the selector gear starts.

By means of frictional resistance, the outer ring is turned one tooth's width by the locking teeth. These locking teeth prevent further sliding of the locking collar on the selector teeth of the selector gear.



- Selected gear



S299_112



S299_130



S299_114

When the speed is equal between the output shaft and the selector gear, there will no longer be any friction. Thanks to its tapered teeth, the outer ring is rotated back into its start position by the locking collar. The locking function is relieved and the locking collar can be pushed onto the selector teeth of the selector gear via the thrust piece.

There is now a positive connection between the output shaft and the selector gear.

Gearbox mechanics

Power development

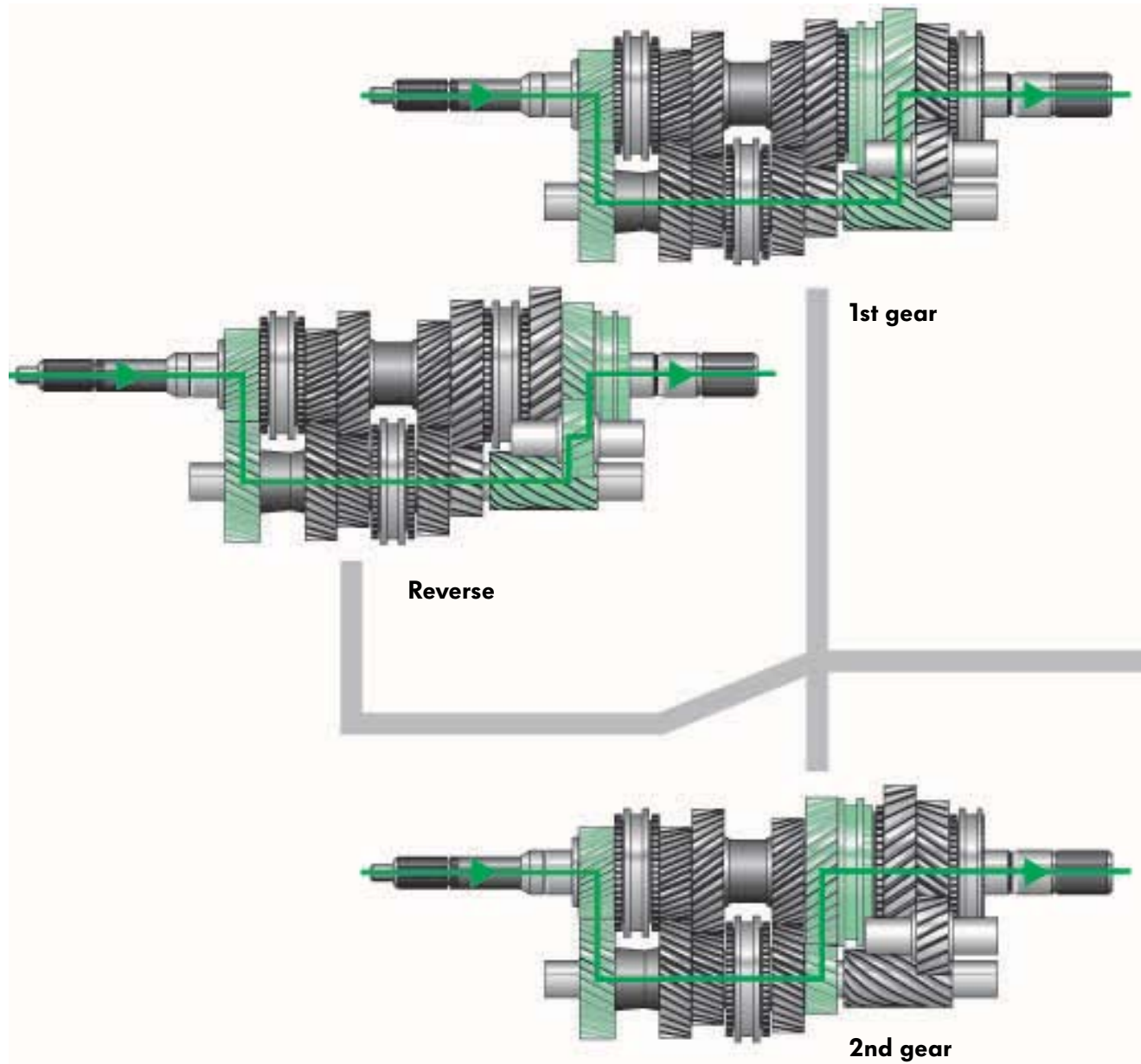

The engine torque is transmitted to the gearbox via the input shaft. Via the gear wheel pairs of the permanently operating constant-mesh gear, the power is transmitted to the layshaft. Depending on which gear is selected, the power is further transmitted via the relevant gear wheel pair to the output shaft. The 5th gear is selected directly. That means that power transmission for this gear is not directed via the layshaft but straight from the input shaft to the output shaft. Connection is made via a locking collar.

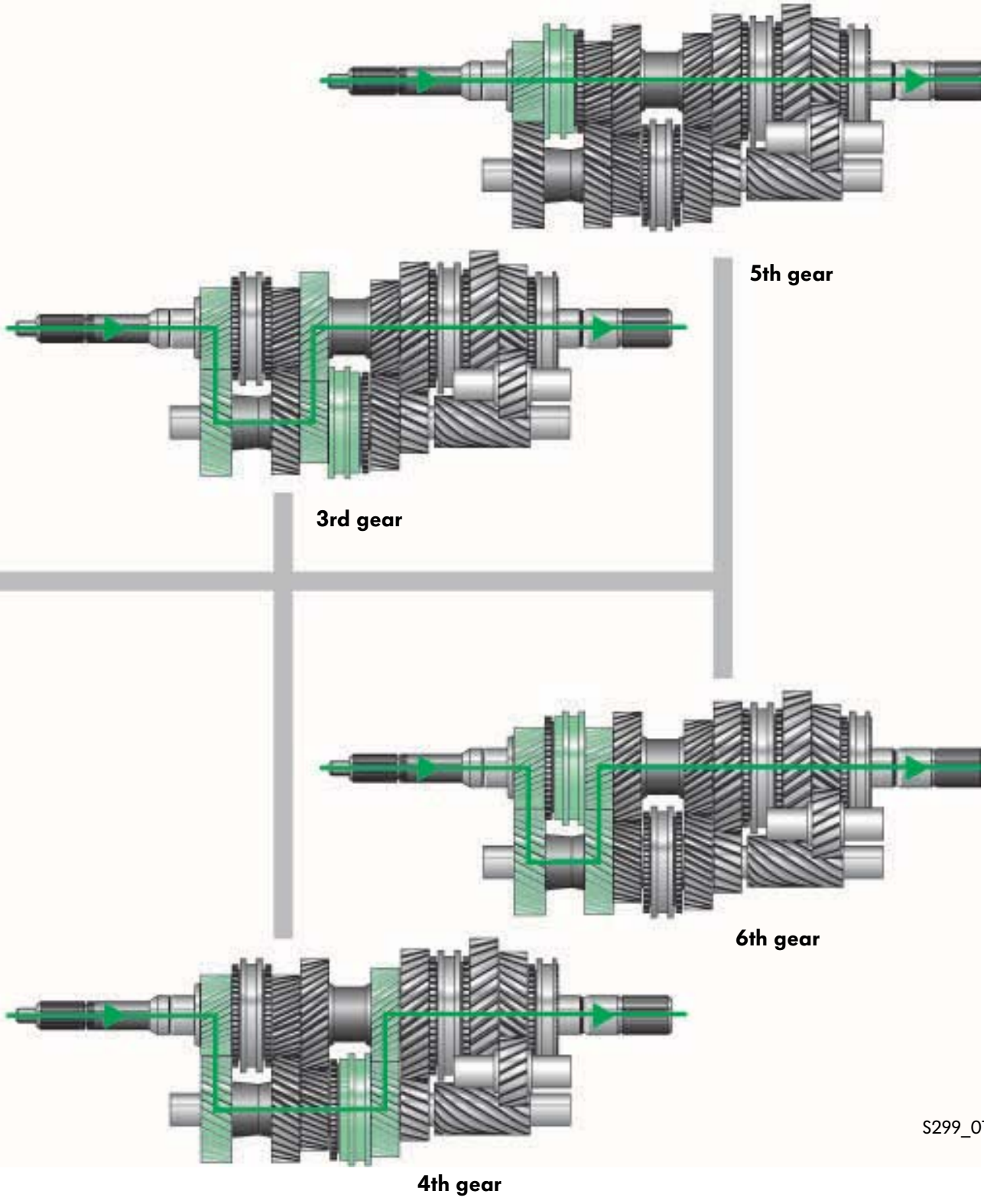

S299_016

Gear selection

Outer selection

The 6-speed manual gearbox O8D is equipped with cable operated gear selection. Two cables, one gate selector cable and one gear selector cable, form the mechanical connection between the gear selector lever in the vehicle and the selector lever on the gearbox.

Components of outer selection are gear selector lever (gearstick) with selector housing, selector cables, support bracket, gear selector lever (gearbox) and gate selector lever.

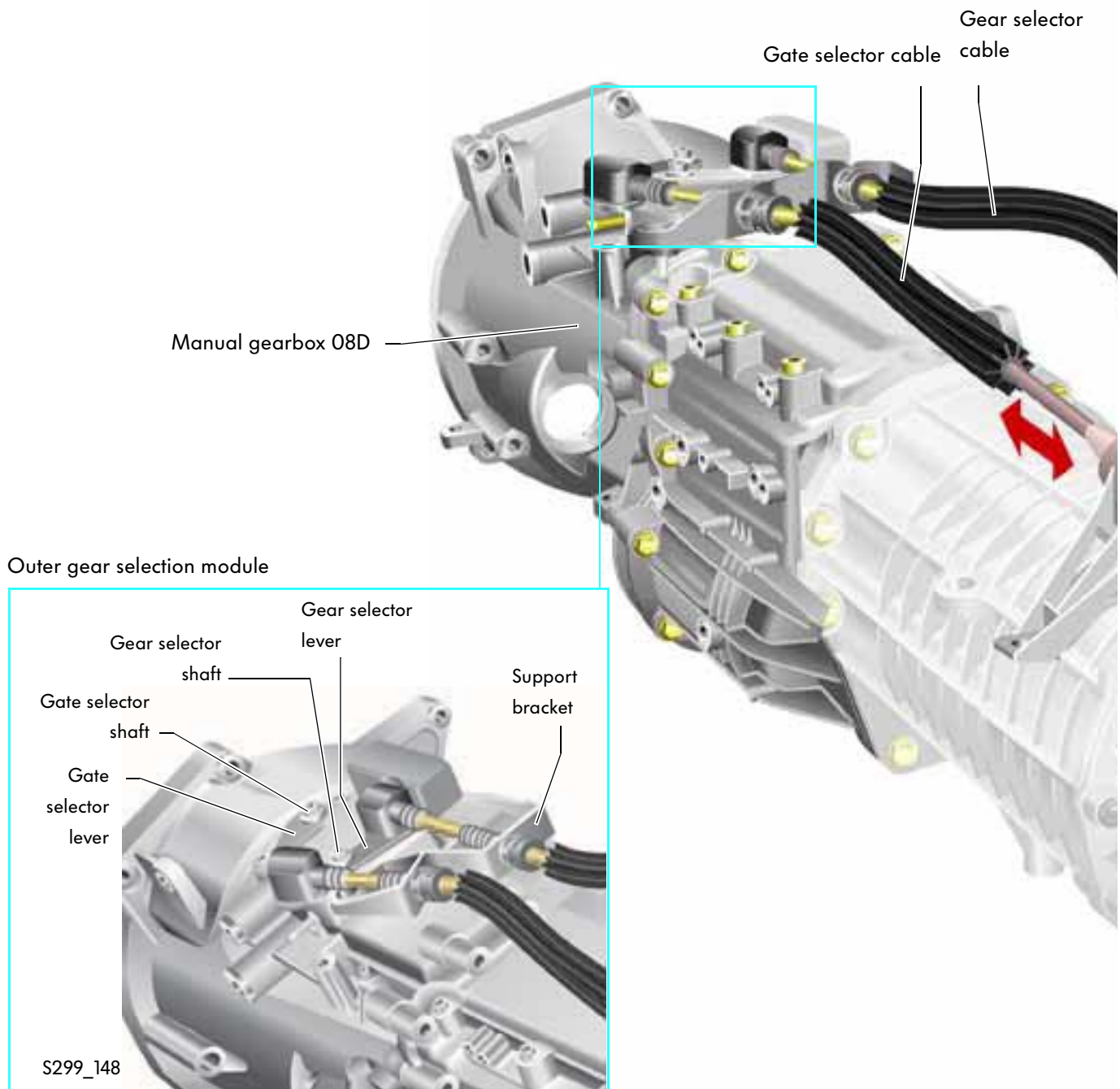

In the gear selector housing, the gear and gate selector movements of the gearstick are converted into axial movements of the cables.

On the outer gear selector module, the axial movements of the cables are converted into rotational movements of the gear and gate selector shafts.

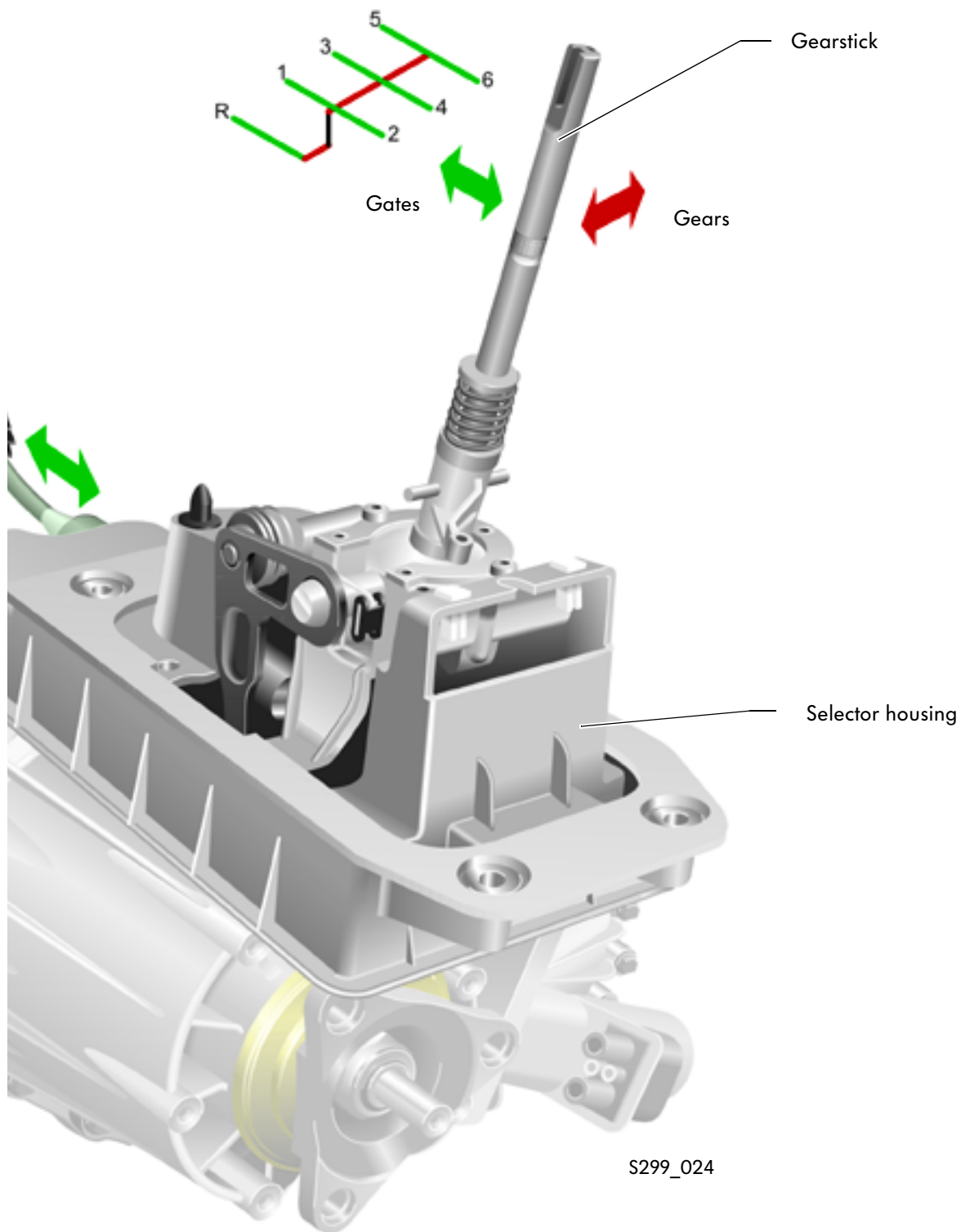

S299_024

Gear selection

Gate selector movement

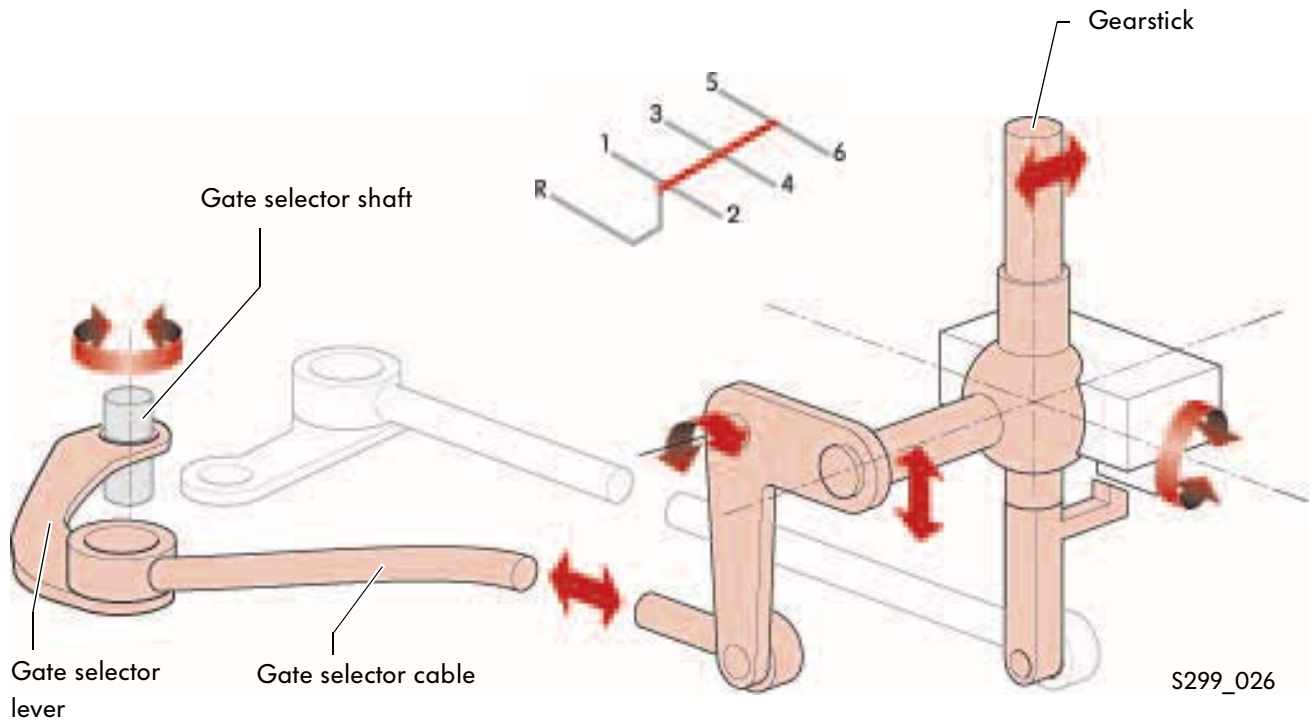

The gate selector movement (left and right) from the gearstick is transmitted to the gate selector cable and converted into a fore and aft movement.

The outer mechanics on the selector module convert the movement of the gate selector cable into a rotational movement. This rotational movement is directed into the selector module via the gate selector shaft.

Gear selection

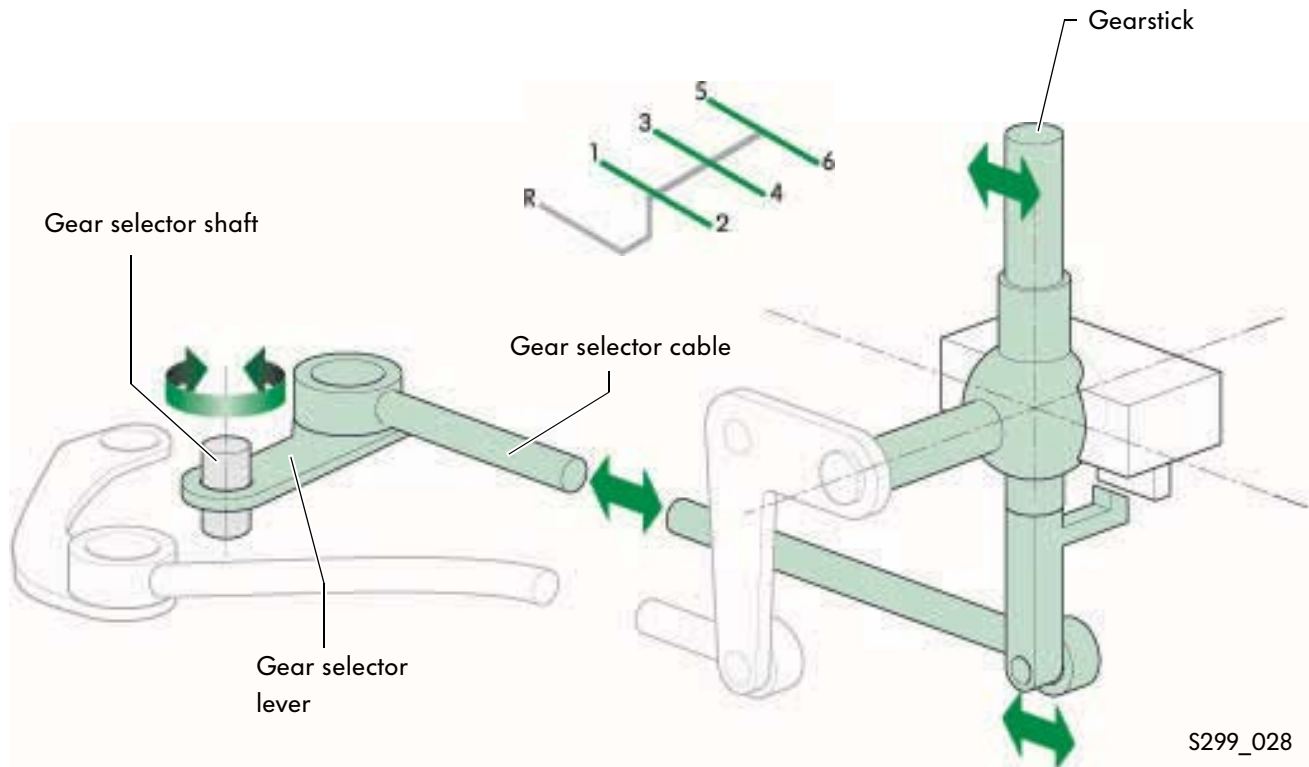

The fore and aft movement of the gearstick is transmitted to the gear selector cable.

The axial movement of the gear selector cable is converted into a rotational movement on the selector module and this movement is then transmitted into the selector module via the gear selector shaft.



Gear selection

Inner selection

Inner selection can be split into three sub-systems.

- Selector module
- Gearbox gear selection
- Locking

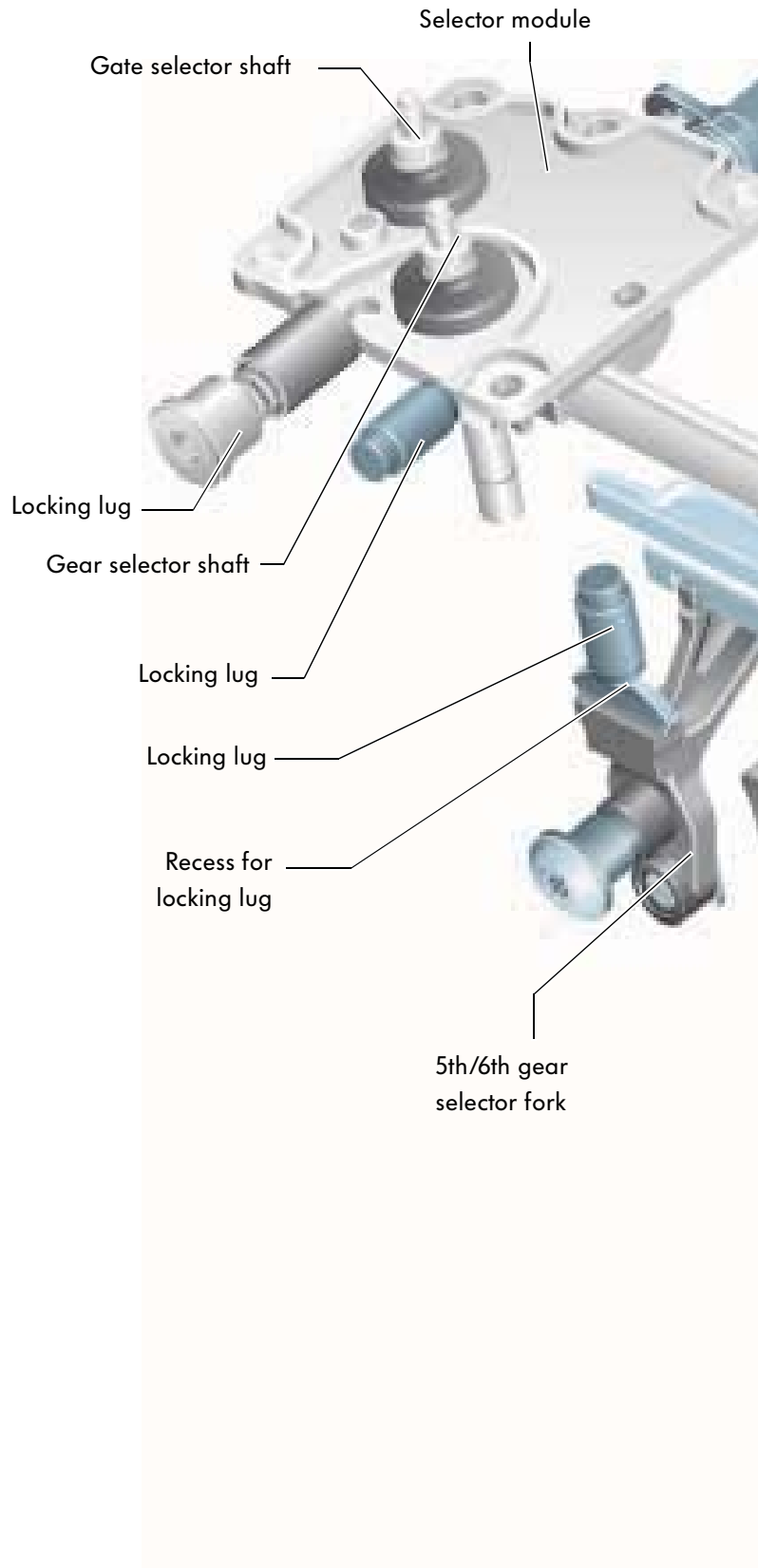

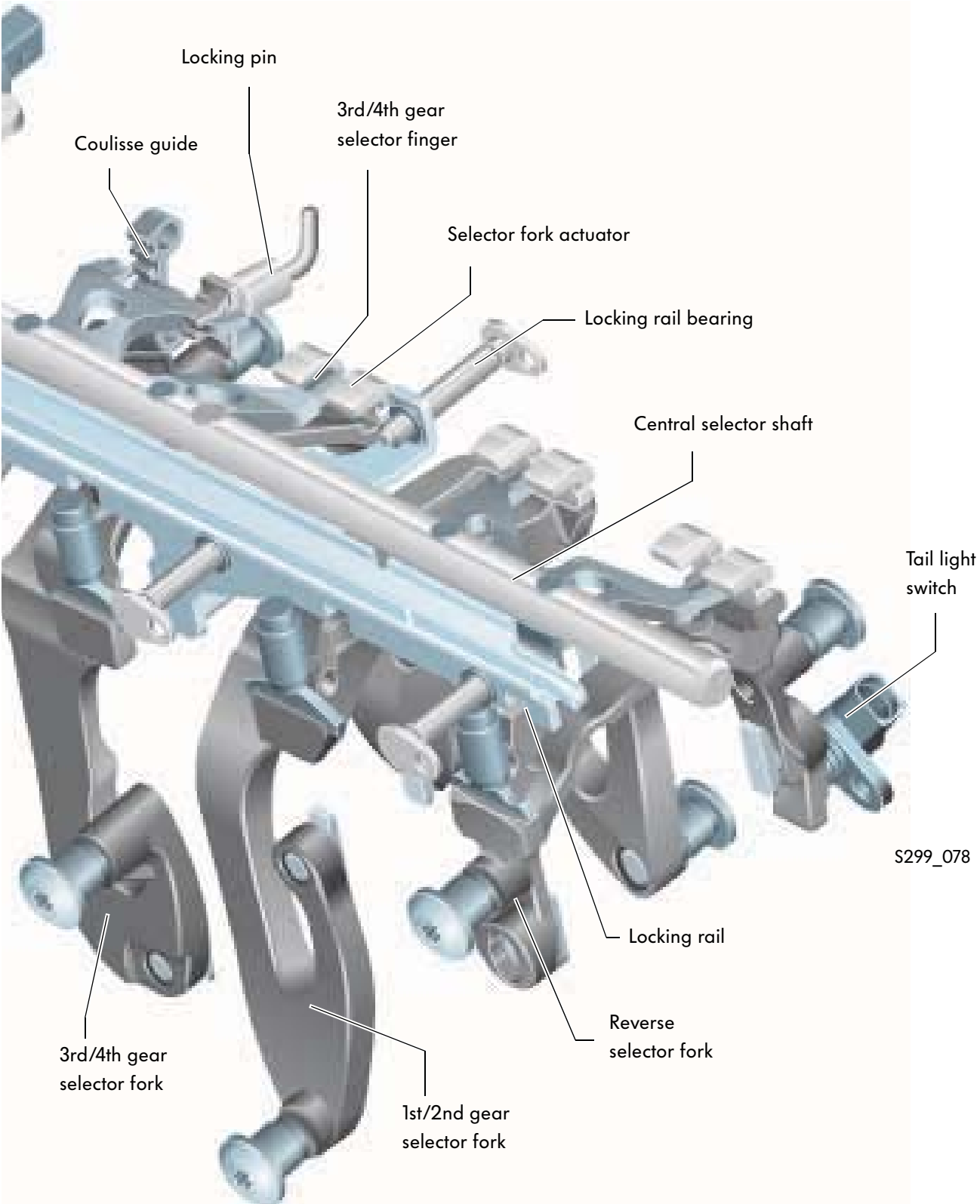

Gear selection

Central selector shaft

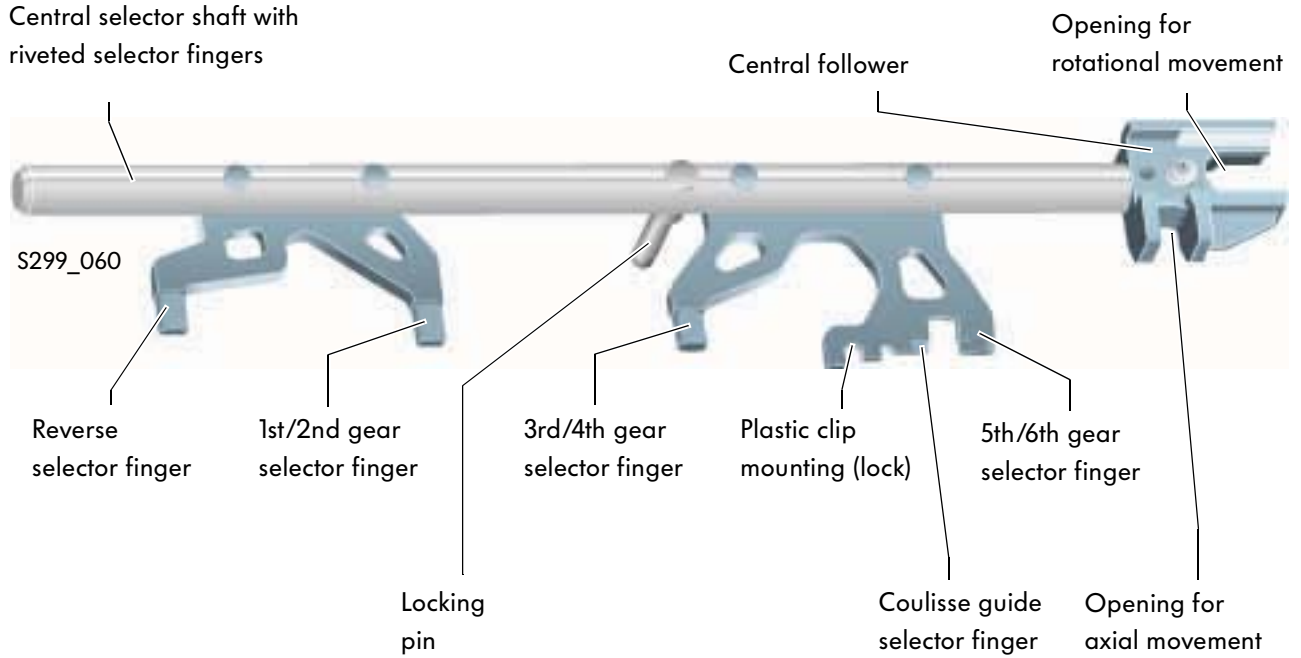

Locking

The locking mechanism consists of a locking rail and a locking bar.

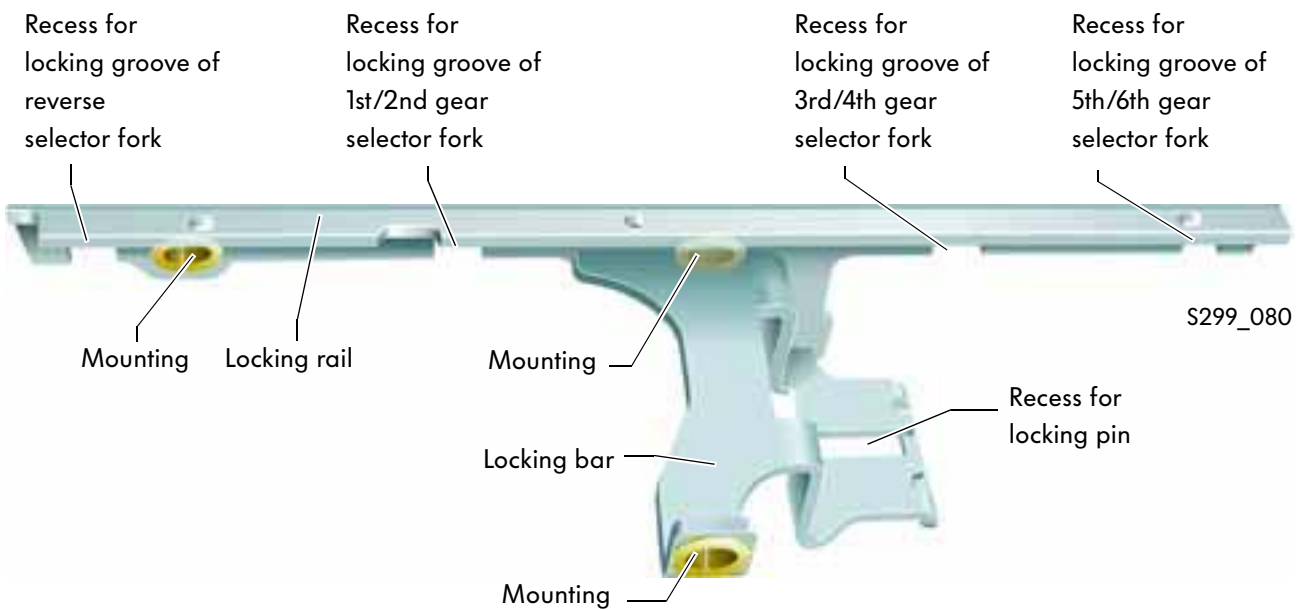

Selector forks

The forks are aluminium cast parts.

The non-symmetrical design of the shoulders guarantees that, despite one-sided power transmission to the fork actuator, there is balanced power transmission to both guide pieces. This prevents canting of the locking collar.

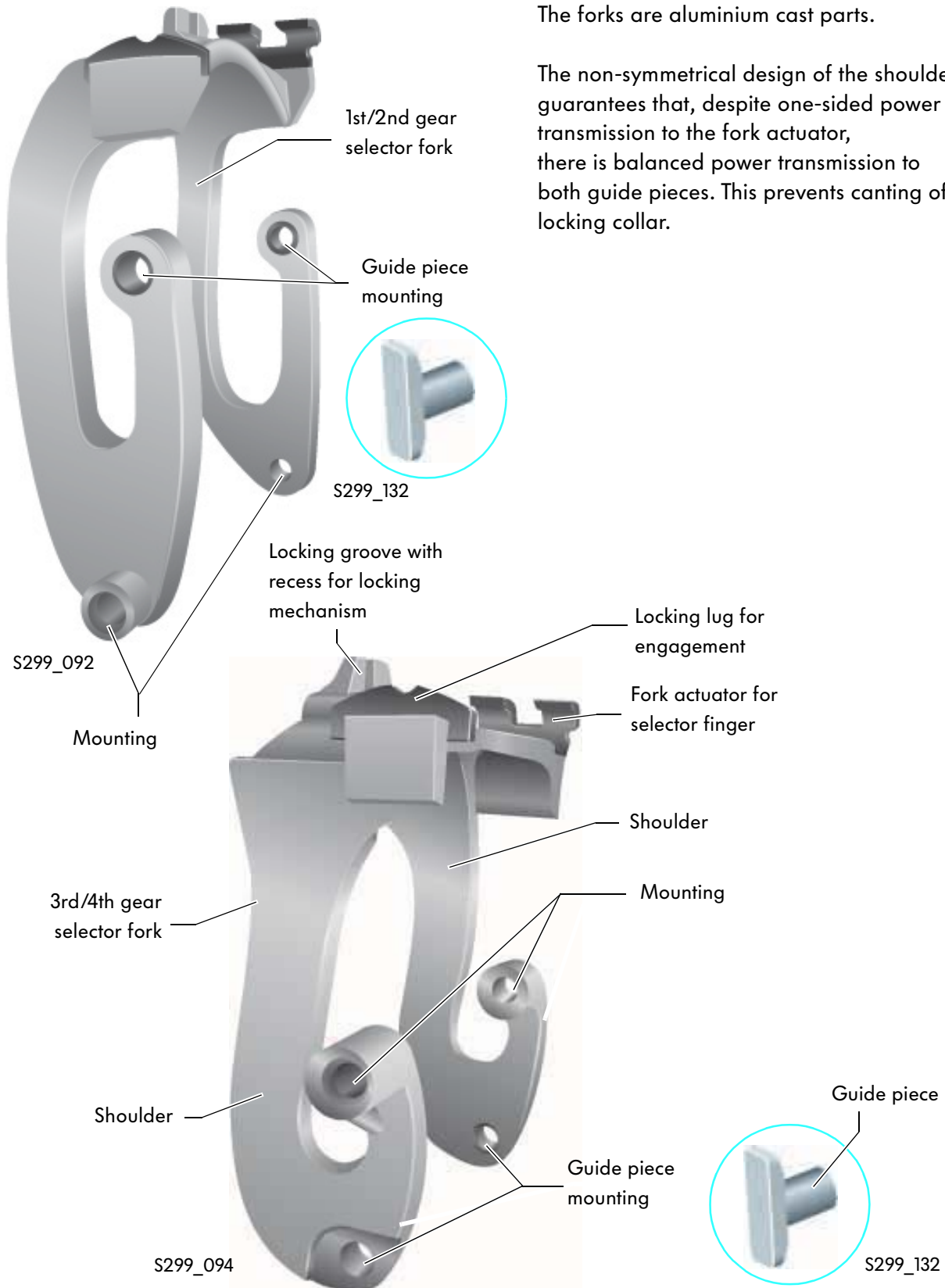

Gear selection

Selector module

The selector module is an item of equipment that converts the movements of the cables into radial movements (gate) or axial movements (gear) and directs them onto the central selector shaft.

The gate selector movement

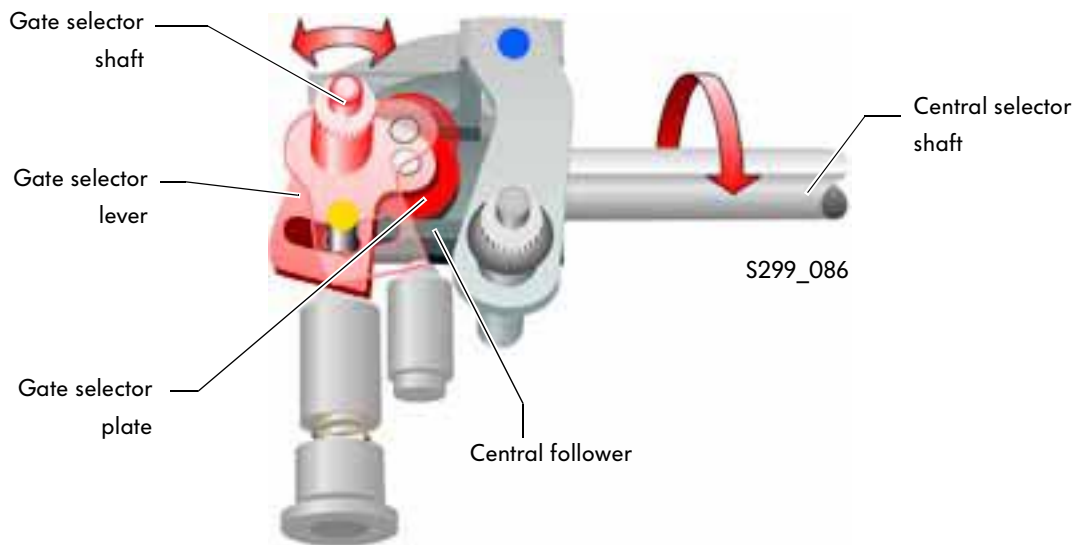

The gate selector shaft is fixed to a gate selector lever. On this there is a gate selector plate that engages in the central follower that is connected to the central selector shaft. Depending on the direction of the gate selector shaft, the selector plate is actuated and transmits a levering force on the central follower. The central selector shaft will rotate.

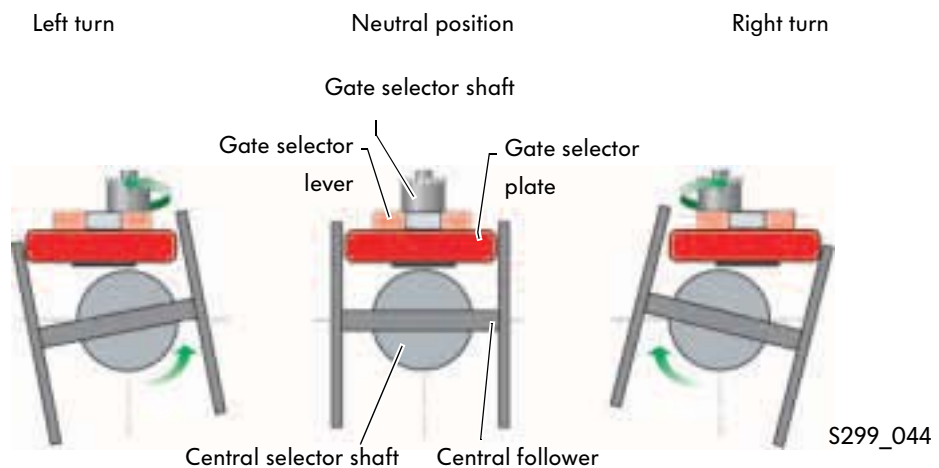

Gear selection

The gear selector shaft is fixed to a gear selector lever. The guide pin of the gear selector lever engages in the groove of the central follower.

When the selector shaft rotates, the central selector shaft is moved in the axial plane by means of leverage from the gear selector lever.

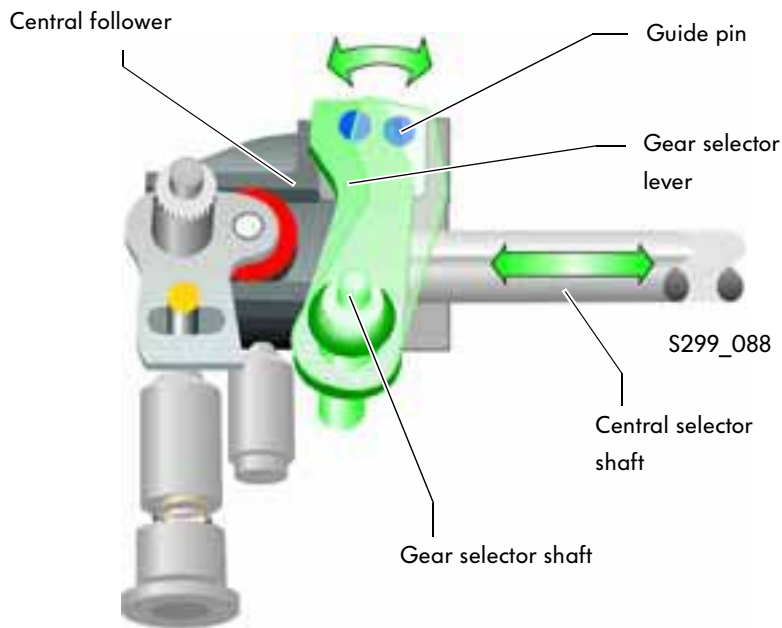

Right turn

Neutral position

Left turn

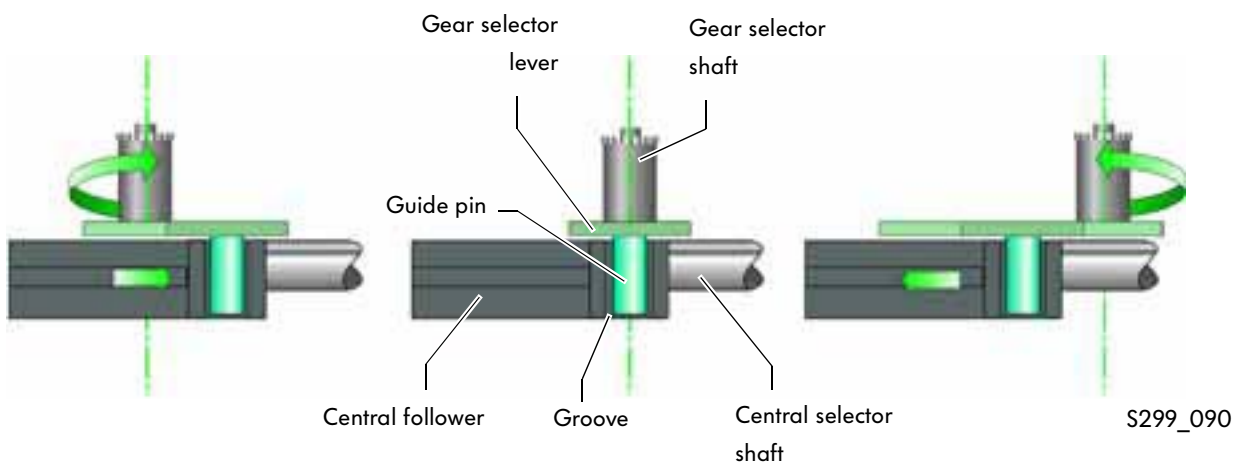

Gear selection

Gearbox gear selection

Gate selector movement

Selector fingers are attached on the central selector shaft at various angles. By means of the radial movement of the central selector shaft, the selector fingers will engage in the respective selector forks, depending on the gate selected (1st/2nd; 3rd/4th; 5th/6th or reverse).

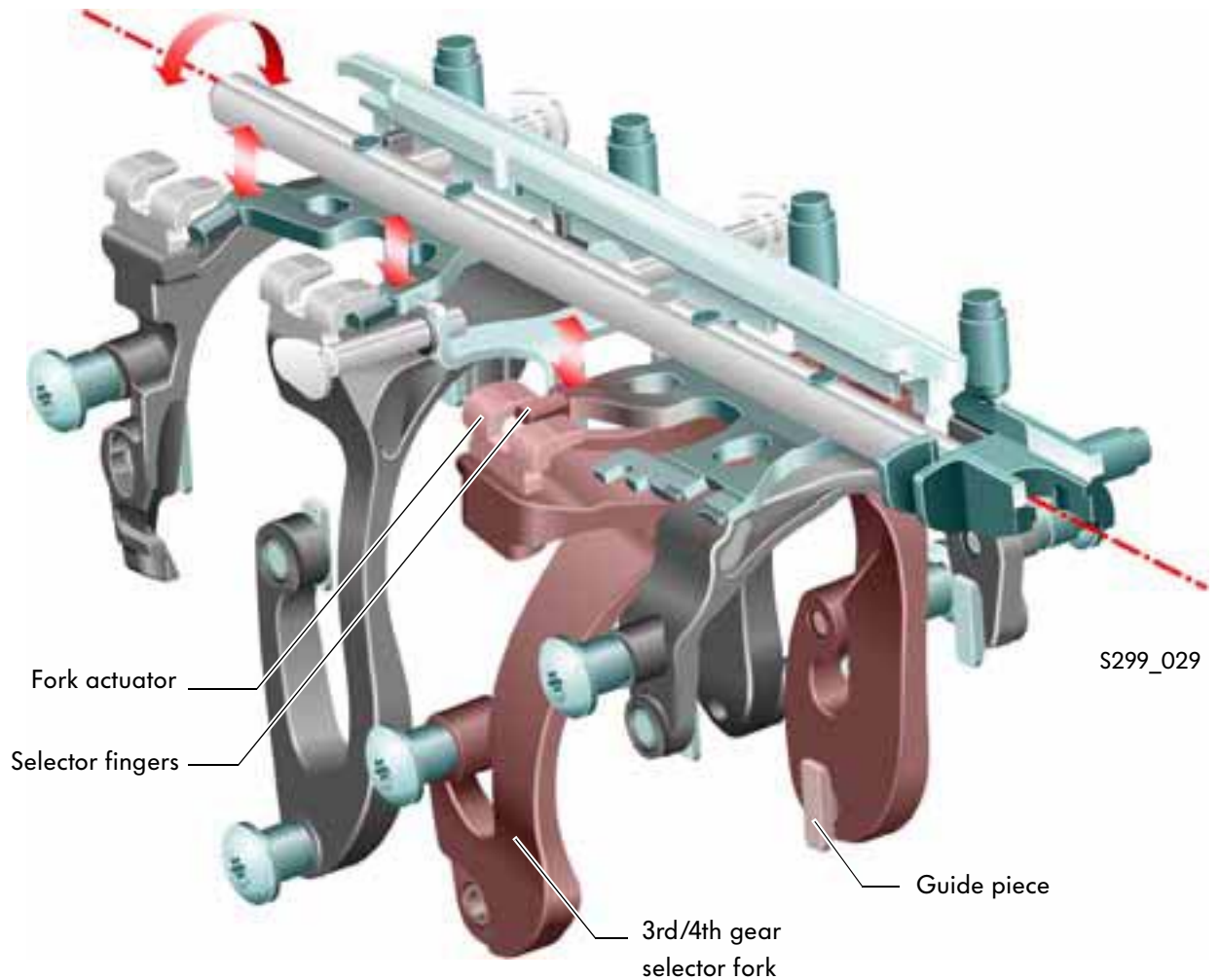

Gear selection

The axial movement of the central selector shaft causes a tilting action of the selector fork via the respective fork actuator. The selector fork bearing is the pivot point for this tilting action.

The tilting action of the selector fork is transmitted as an axial movement to two guide pieces. The guide pieces engage in the locking collar which has been guided onto the synchro-hub. From the neutral position, the locking collar is moved in the direction of the selector gear and this joins the selector gear with the output or layshaft, depending on the gear selected.

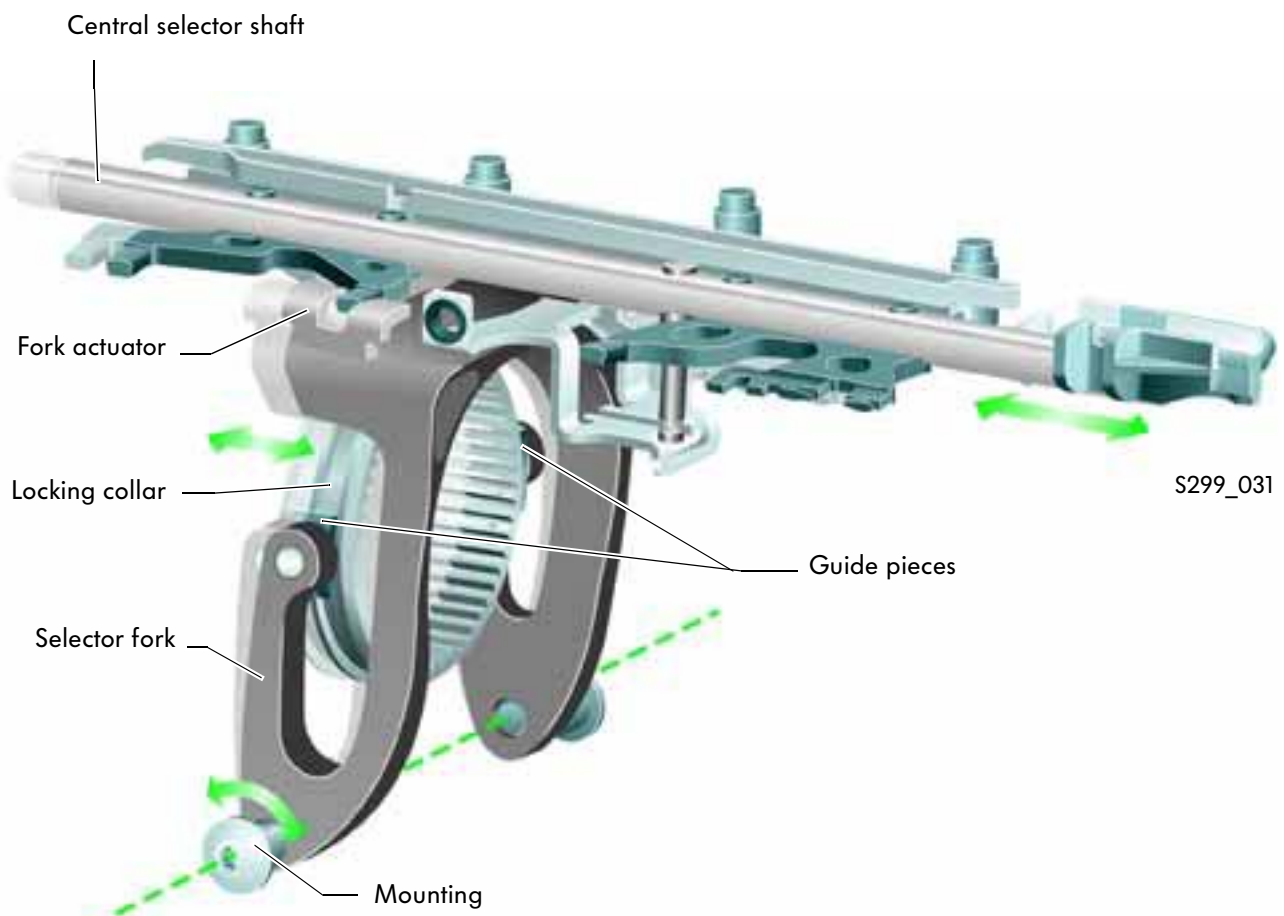

Gear selection

Locking

The locking mechanism is a locking rail. It is an active system.

The gate selector movement of the central selector shaft activates the lock via the lock rail.

The rotational movement of the central selector shaft is converted into a linear transverse action of the locking rail via a locking pin that engages in the locking bar. That means that the locking rail is moved transversely towards the selector forks.

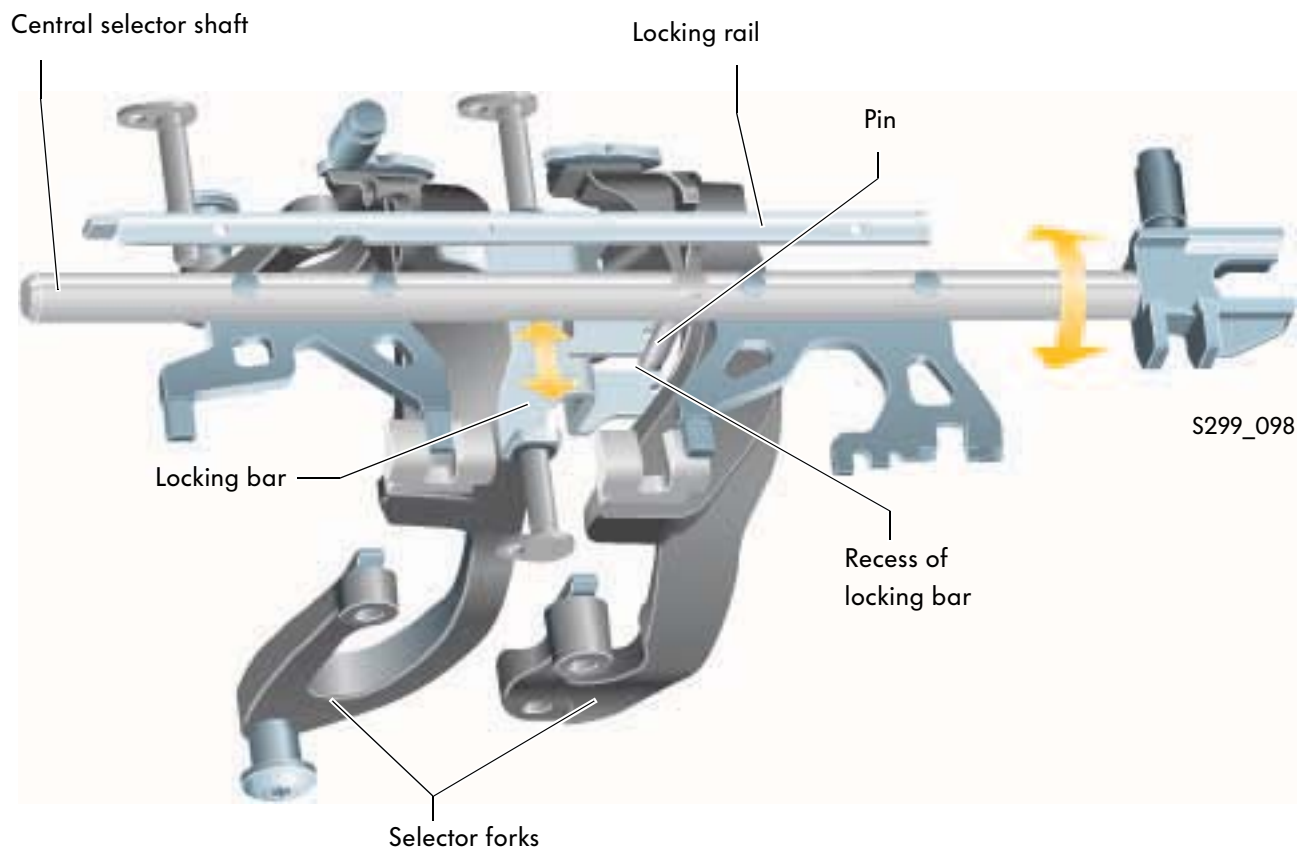

The recesses in the locking rail and locking grooves of the selector forks are laid out in such a way so as to allow movement of just one selector fork while the others are locked in position.

By means of the recess in the locking groove, the active selector fork can be moved along the locking rail. That means that a gear can be selected while the other selector forks are locked. Unintentional selection of more than one gear is prevented by the lock.

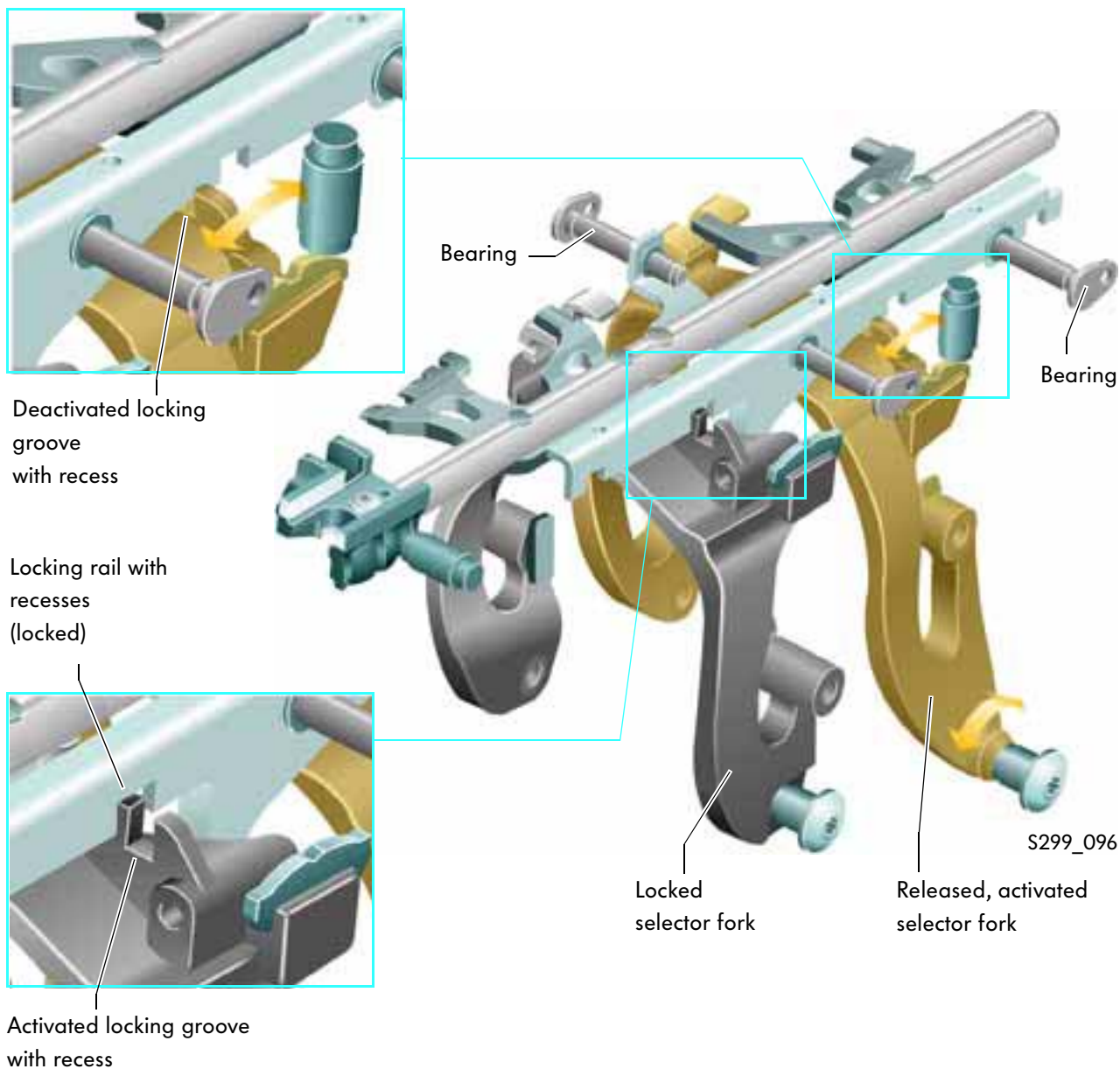

Gear selection

Locking mechanism

The locking mechanism is installed to safeguard selection of the individual gears. Each selector fork has the task of selecting 2 gears and features a locking mechanism for the idle position.

This locking mechanism has a further effect in that it applies additional force in the direction of gear selection, which supports the movement of the locking collar.

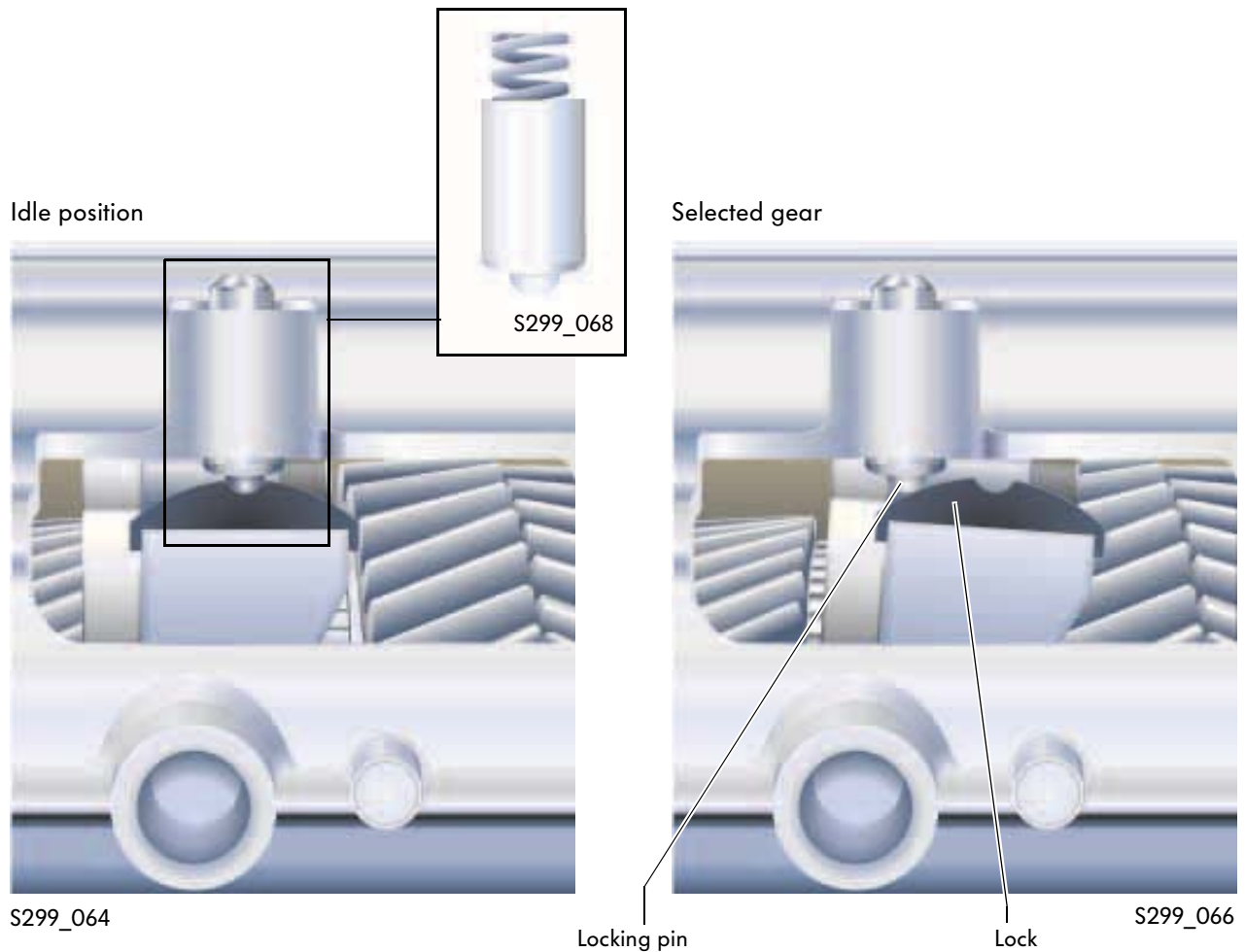

Guide coulisse

Thanks to the guide coulisse, transverse play at the gearstick is minimised.

A guide finger attached to the central selector shaft engages in the respective groove of the guide coulisse, depending on the gate selected. This reduces gate lever play and also supports the central selector shaft against rotational forces.

In this way the guide coulisse secures the central selector shaft in the selected gear position and maintains the position of the gearstick in the respective gate (with gear selected).

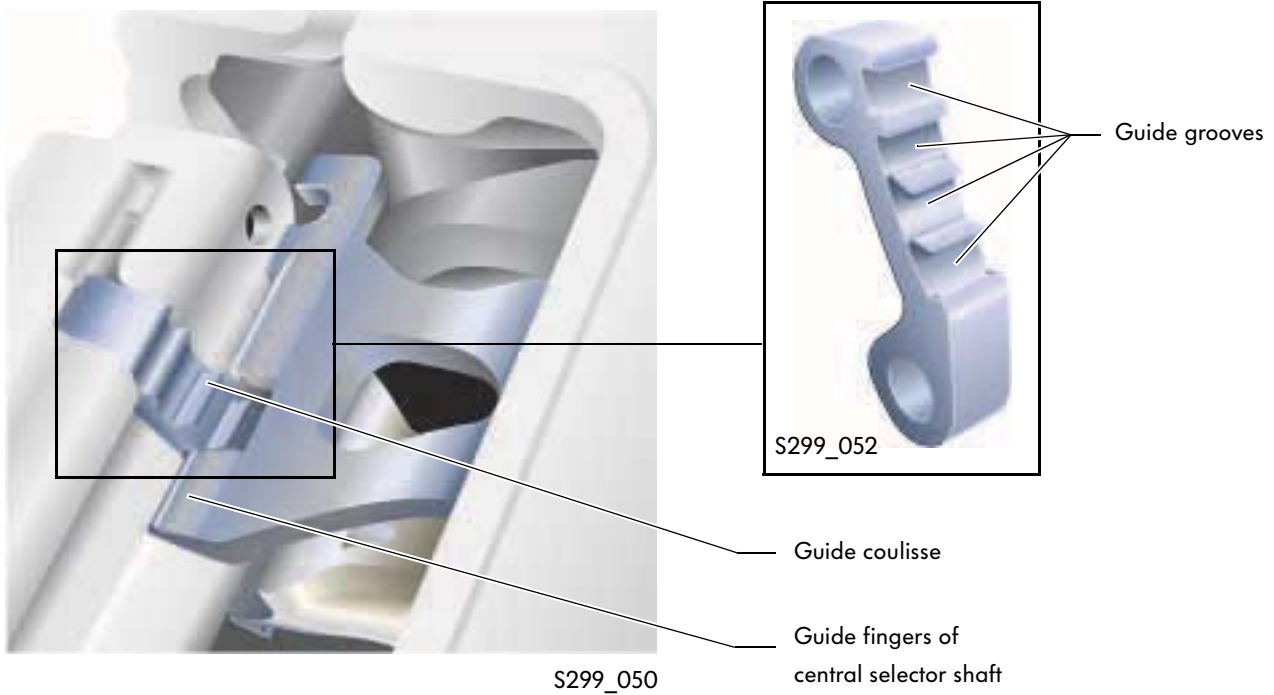

Sensors

Tail light switch

The tail light switch can be found on the right hand side of the gearbox as seen facing normal direction of travel.

When reverse gear is selected, the electrical circuit to the tail lights is closed via this switch. The switch is activated by the selector fork for reverse gear.

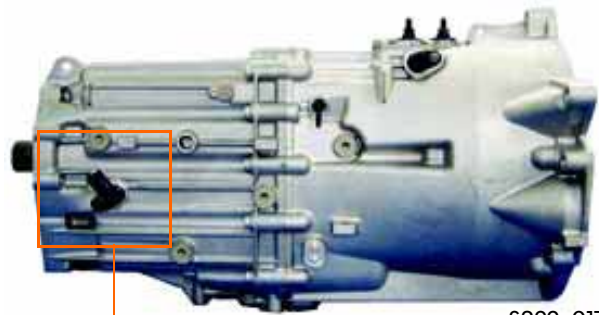

S299_017

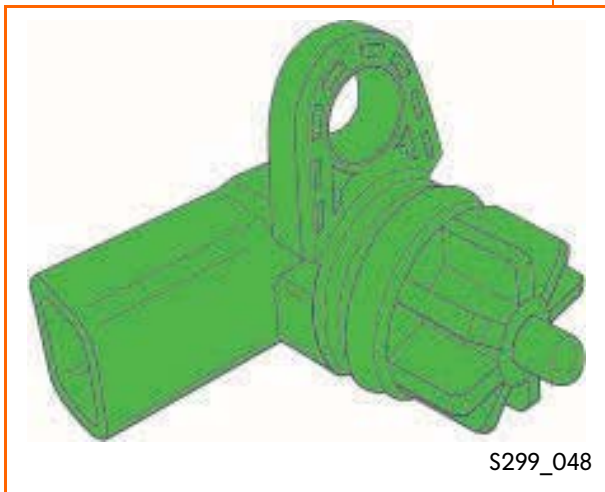

S299_048

Adjusting selection cables

To adjust the selector cables, the gearstick is held in place using locating pin T10027 with loose selector cables.

The locking pin can be found on the right-hand side of the gearbox, as seen when facing normal direction of travel. By rotational force, the central selector shaft is thereby fixed in place.

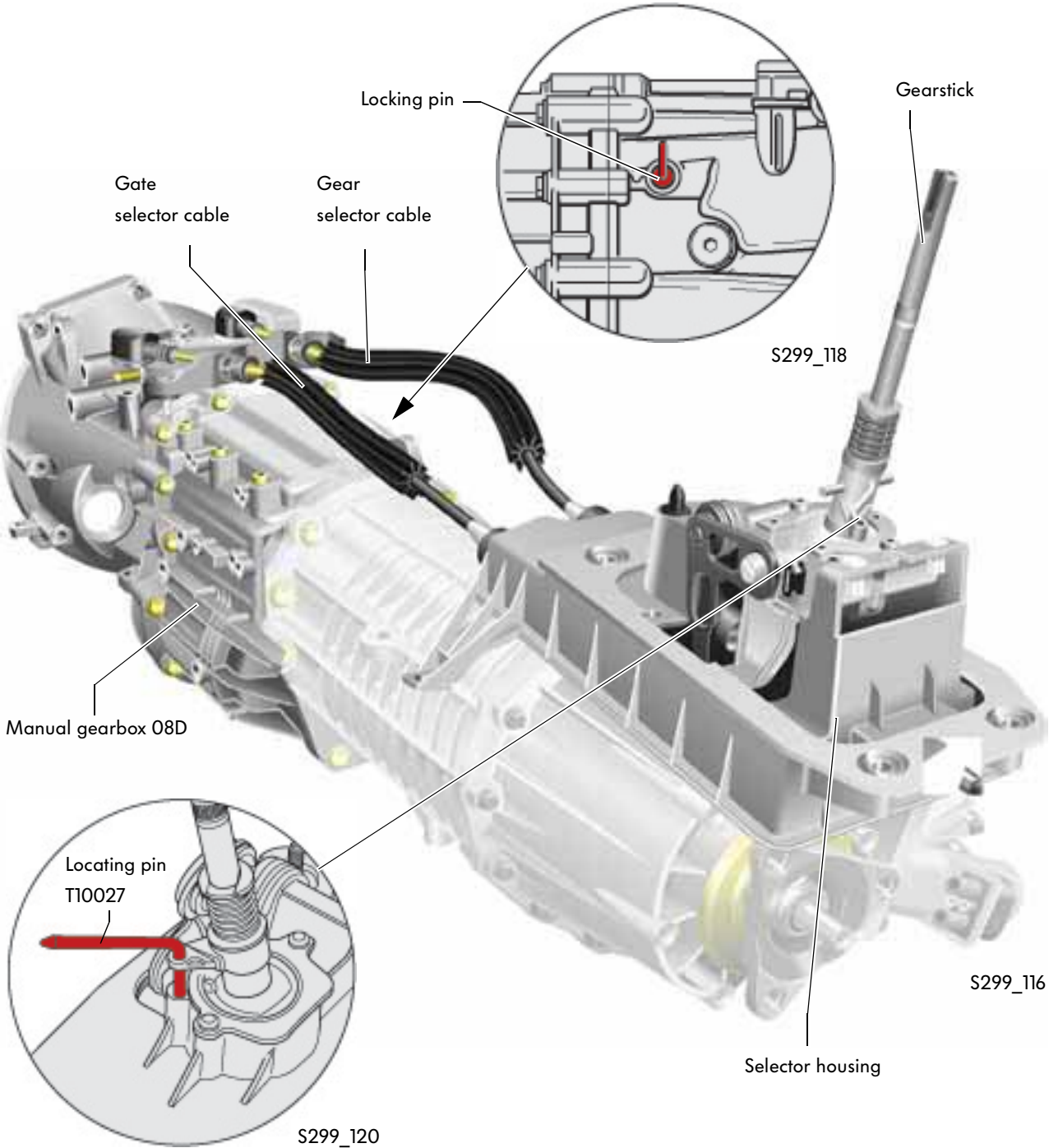

Service

Releasing gate selector cable

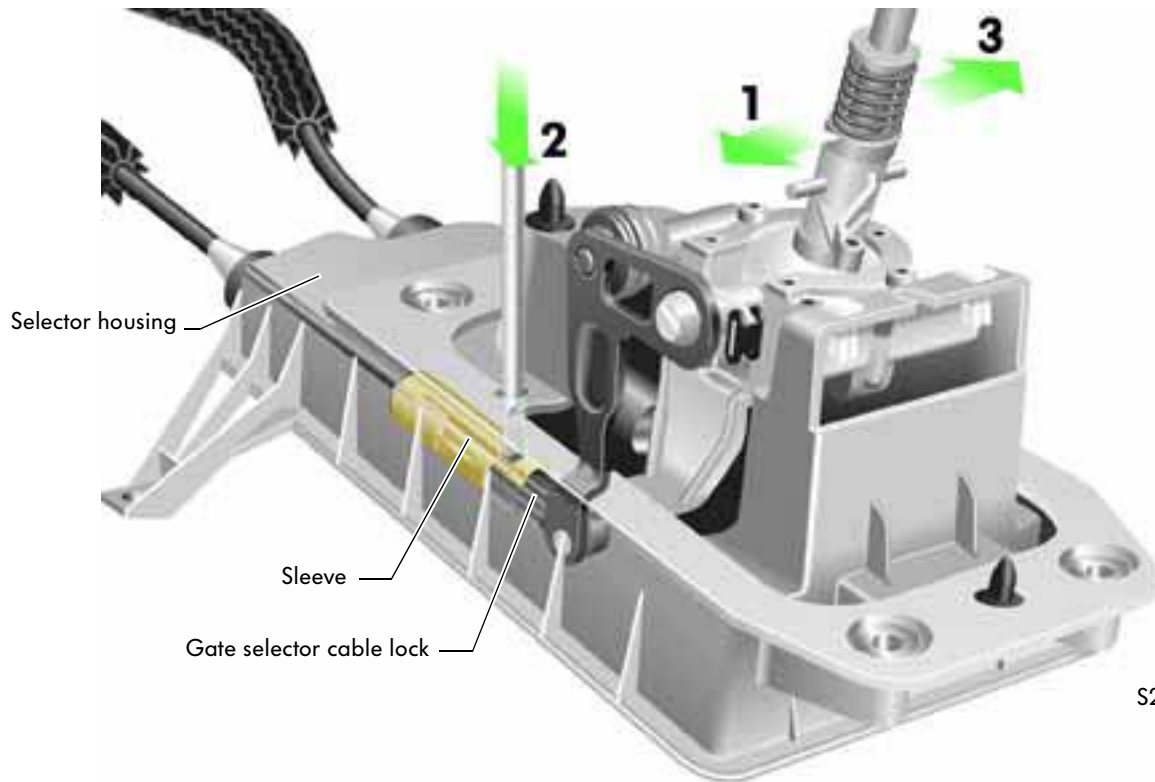

S299_140

To release the gate selector cable, the gearstick must first be moved to the left (1) in the gate for 1st/2nd gear. This positions the gate selector cable locking mechanism under the opening in the selector housing.

A screwdriver (2) can then be inserted in the opening and the sleeve from the gate selector cable lock can be held in place.

If the gearstick is now moved to the right (3) in the gate for 5th/6th gear, the gate selector cable lock will be placed under load.

The gate selector cable is released.

Releasing gear selector cable

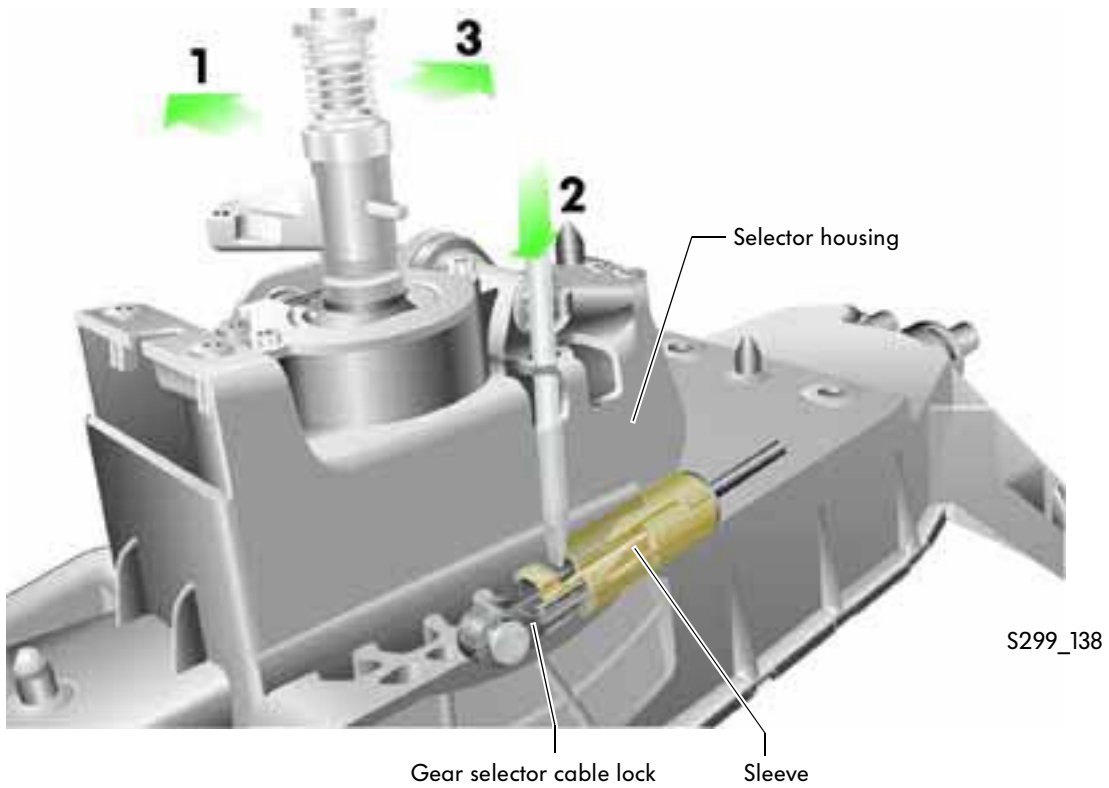

The first step is to move the gearstick to the left (1) in the gate for 1st/2nd gear.

A screwdriver (2) can then be inserted in the opening and the sleeve from the gear selector cable lock can be held in place.

The gearstick is now moved forwards (3) which places the gear selector cable lock under load.
The gear selector cable is released.

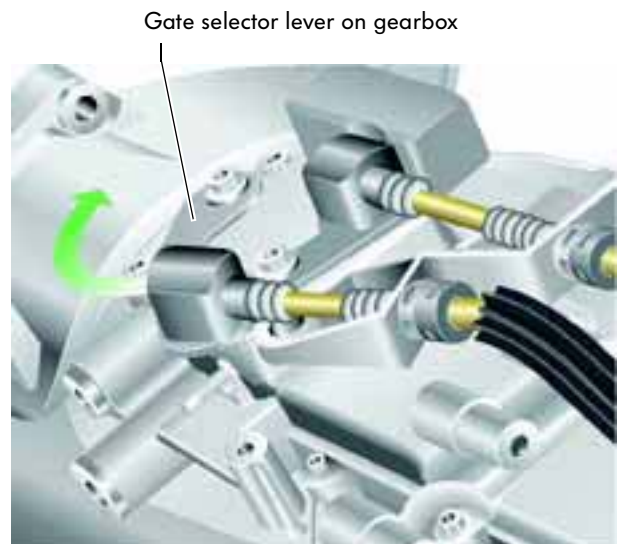

The gate selector lever on the gearbox is then moved forwards approx. half the possible travel.
The central selector shaft can now be held in place by the locking pin and the gearstick can be held in place by the locating pin (as described on the following page) to allow the cables to be fixed in position.



Service

Securing central selector shaft

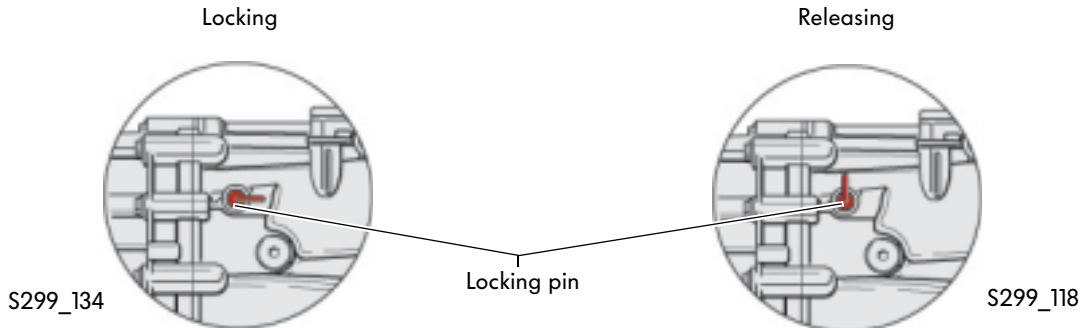

To hold the central selector shaft in place, the inner selection mechanism must be fixed in the gate for 1st/2nd gear (in neutral position). To do this, there is a locking pin on the right-hand side of the gearbox, as seen when facing normal direction of travel.

When the gate for 1st/2nd gear is selected, this locking pin can be rotated clockwise by 90 degrees and inserted to engage in one of the locking bars located on the central selector shaft. The central selector shaft is now held in place.

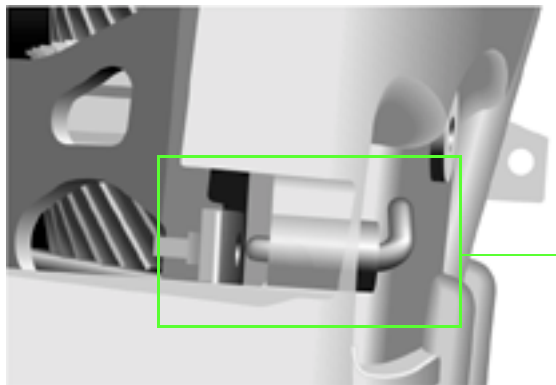

S299_128

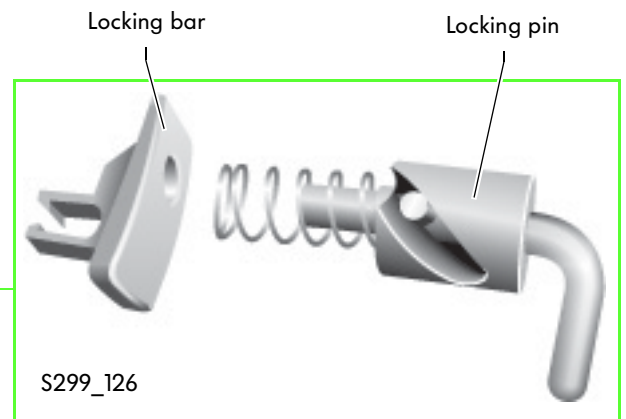

Once the cables have been adjusted, the locking pin must be turned anti-clockwise, removed and locked.

Holding gearstick in place

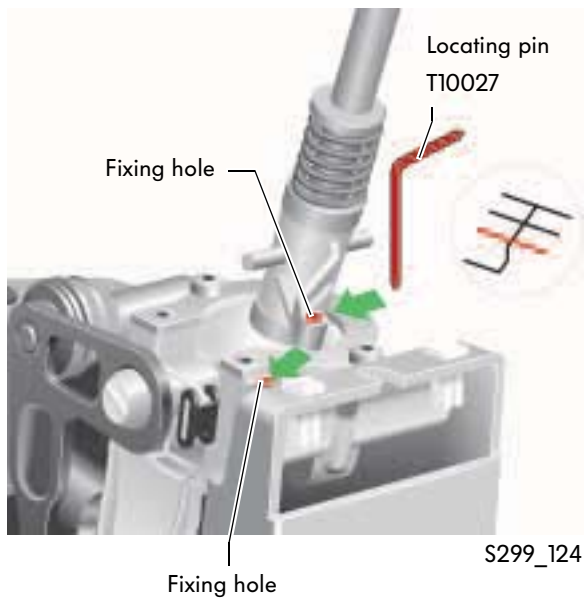

The gearstick is placed in the idle position in the gate for 1st/2nd gear until the locating holes on the gearstick and in the selector housing are aligned. The locating pin T10027 can now be inserted.

Clamping selector cables



To clamp the gate or gear selector cables, the respective locking mechanism must be activated in the selector housing. To do this, press against the bar of the gear or gate selector cable locks using a screwdriver.

Once this has been done the locking pin on the gearbox can be turned clockwise and pulled out and the locating pin T10027 can be removed.



Test yourself

1. The transmission housing is made of aluminium and consists of:

- a) One housing part, the housing shell
- b) Two housing parts, the bell housing and the gearbox rear part.
- c) Three housing parts, the bell housing, the selector cover and the gearbox rear part.

2. In the 08D gearbox there are three shafts.

Which shafts can be found in one plane and have a joint bearing mounting?

- a) The output shaft and the layshaft
- b) The input shaft and the layshaft
- c) The input shaft and the output shaft

3. The gearbox features three different types of synchronisation.

Which gear wheel pair is equipped with 3-cone synchronisation?

- a) 1st and 2nd
- b) 3rd and 4th
- c) 5th and 6th



4. What is meant by this: "The 5th gear is selected directly"?

- a) Engine power is transmitted from the layshaft to the output shaft.
- b) Engine power is transmitted from the input shaft to the layshaft and then to the output shaft.
- c) Engine power is not transmitted via the layshaft.
- d) Engine power comes directly from the input shaft to the output shaft.
Connection is made via a locking collar.

5. Which function does the selector module have?

- a) The selector module converts the movements of the cables into radial movements (gate) or axial movements (gear) and directs them onto the central selector shaft.
- b) The selector module is for alternative selection. If the selector forks become blocked, secure and comfortable selection is realised regardless.
- c) The selector module allows faster action of the locking collar. The energy required for selection is thereby supported.

6. What role does the guide coulisse have?

- a) By means of the guide coulisse, unintentional selection of more than one gear is prevented.
- b) By means of the guide coulisse, transverse play at the gearstick is minimised.



Notes

Answers

1.) b

2.) c

3.) a

4.) c, d

5.) a

6.) b

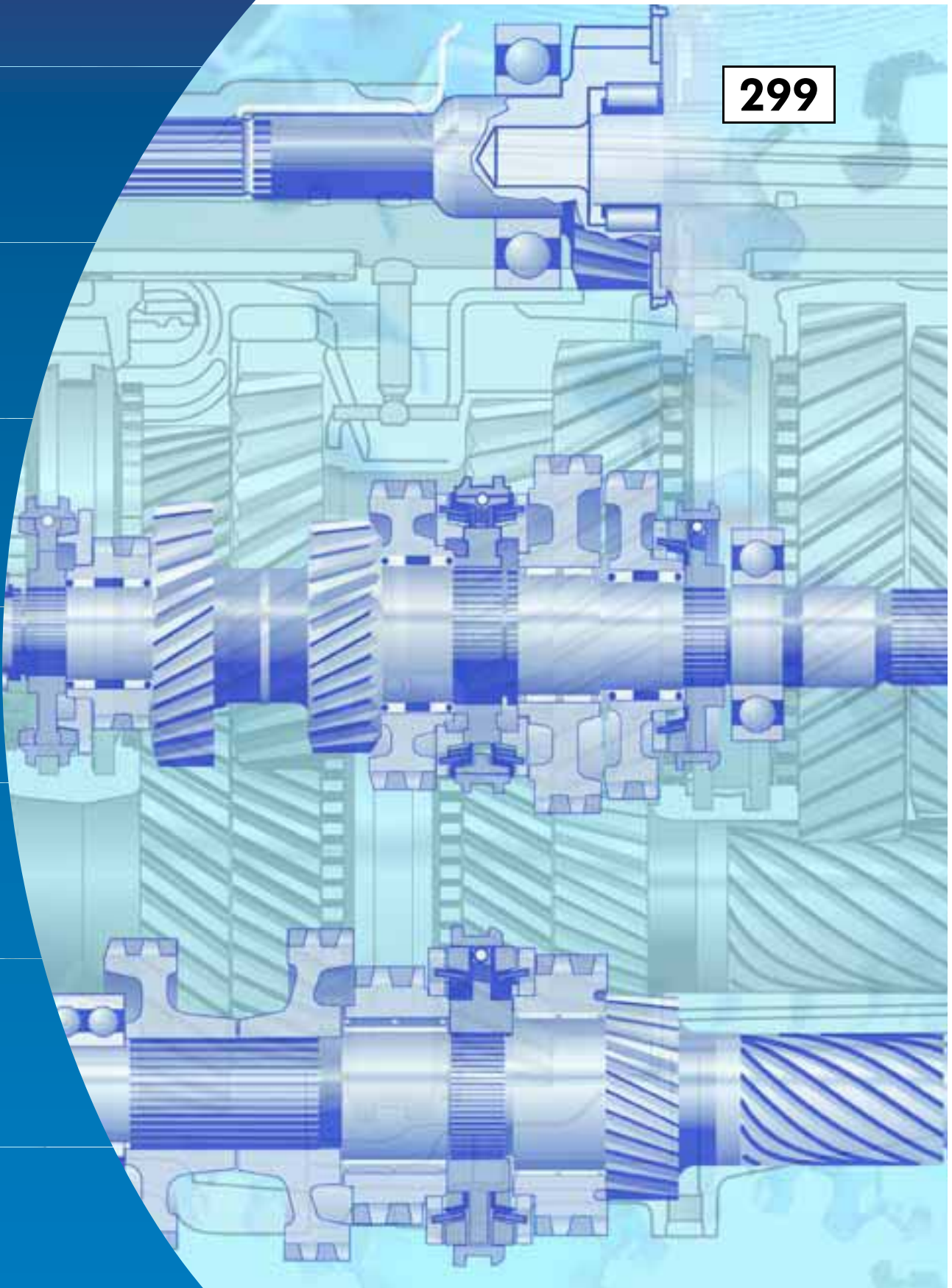

For internal use only © VOLKSWAGEN AG, Wolfsburg

All rights and the right to make technical alterations reserved

000.2811.19.20 Technical status 11/02

 This paper was manufactured from pulp that was bleached without the use of chlorine.