

Service.



## Self study programme 296

# The 1.4 ltr. and 1.6 ltr. FSI engine with timing chain

Design and function

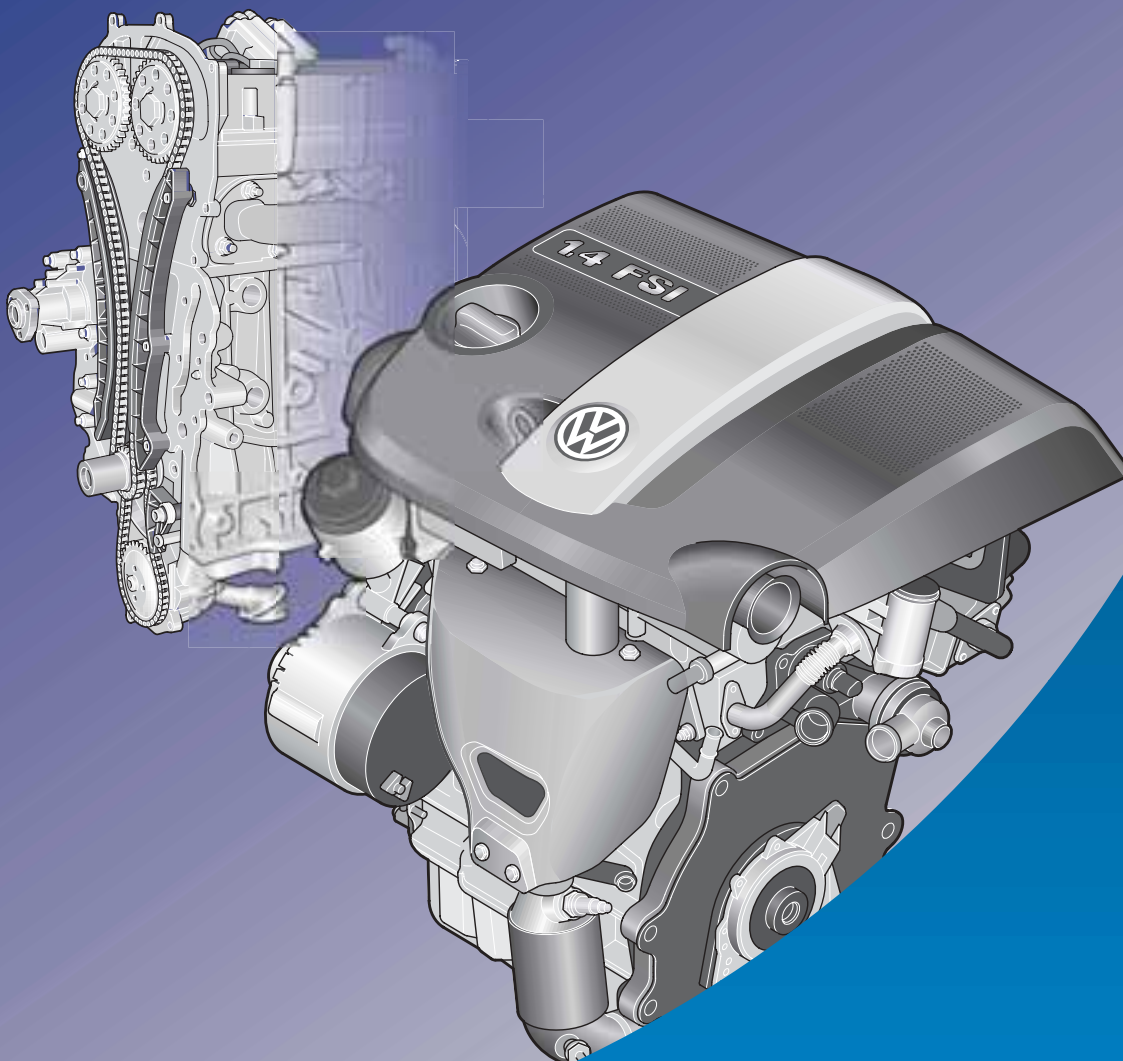

For Volkswagen, new and further development of engines with direct petrol injection is an important contribution towards environmental protection. The frugal, environmentally-friendly and powerful FSI engines are offered in four derivatives for the following vehicles:

- 1.4 ltr./63 kW FSI engine in the Polo
- 1.4 ltr./77 kW FSI engine in the Lupo
- 1.6 ltr./81 kW FSI engine in the Golf/Bora
- 1.6 ltr./85 kW FSI engine in the Touran



S296\_008

In this self-study programme you will be shown the design and function of the new engine mechanical and management systems.

Further information about engine management can be found in self-study programme 253 "The petrol direct injection system with Bosch Motronic MED 7".

**NEW**



**Important Note**



**The self-study programme shows the design and function of new developments!  
The contents will not be updated.**

For current testing, adjustment and repair instructions, refer to the relevant service literature.



<b>Introduction</b> .....	<b>4</b>
Technical properties .....	4
Technical data .....	5
<b>Engine mechanics</b> .....	<b>6</b>
Engine cover .....	6
Intake manifold upper part .....	7
Control housing seal .....	8
Electrical exhaust gas recirculation valve .....	9
Cooling system .....	10
Regulated Duocentric oil pump .....	14
Variable valve timing .....	16
<b>Engine management</b> .....	<b>18</b>
System overview .....	18
Engine control unit .....	20
Operating types .....	22
Intake system .....	24
Supply on demand fuel system .....	28
Fuel pump control unit .....	30
Fuel pressure sender .....	31
High pressure fuel pump .....	32
Functional diagram .....	34
<b>Service</b> .....	<b>36</b>
Self-diagnosis .....	36
Special tools .....	37
<b>Test yourself</b> .....	<b>38</b>



Copyright © Volkswagen AG. Volkswagen AG does not guarantee or accept any liability with respect to the correctness of information in this document. Copyright © Volkswagen AG. Volkswagen AG does not guarantee or accept any liability with respect to the correctness of information in this document.

# Introduction

Both engines are basically the same, in that they consist of cylinder block and cylinder head, camshaft drive, control housing, oil pump and ancillaries.

The significant differences of the 1.6 ltr. FSI engine are the greater stroke, variable valve timing and further developed operating condition "double injection".



S296\_011



S296\_051

## Technical properties

### Engine mechanics

- Engine cover with air cleaner and hot air control
- Intake manifold upper part made of plastic
- Camshaft driven by chain
- Continually variable valve timing \*)
- Oil cooler \*)
- Regulated Duo-centric oil pump
- Dual circuit cooling system
- Cross flow cooling in cylinder head
- Crankcase breather system

\*) 1.6 ltr./85 kW FSI engine only

### Engine management

- Petrol direct injection with double injection
- Engine control unit with integrated ambient air pressure sender
- Intake air temperature sender in engine cover
- Supply on demand fuel system
- Single spark ignition coil
- Exhaust gas treatment with NO<sub>x</sub> storage catalyst and NO<sub>x</sub> sender
- Integrated radiator and fan control

The regulated Duo-centric oil pump, the dual circuit cooling system and the supply on demand fuel system are new technologies that will also be used in other vehicles in the future.



## Technical data

1.4 ltr./63 kW FSI engine

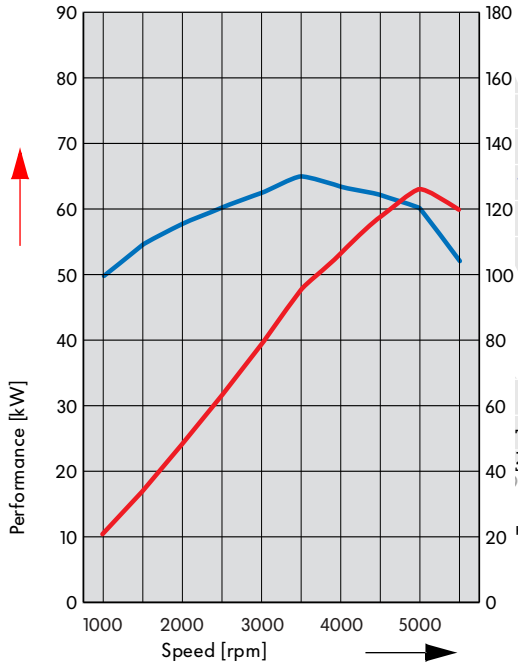

S296\_049

1.6 ltr./85 kW FSI engine

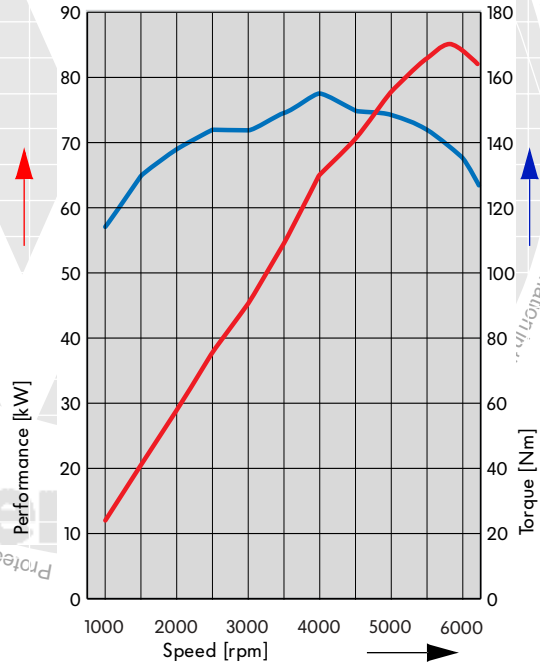

S296\_050

Engine codes	AUX	BAG
Displacement	1390	1598
Type	4-cylinder in-line engine	4-cylinder in-line engine
Valves per cylinder	4	4
Bore	76.5 mm	76.5 mm
Stroke	75.6 mm	86.9 mm
Compression ratio	12:1	12:1
Maximum output	63 kW at 5000 rpm	85 kW at 5800 rpm
Maximum torque	130 Nm at 3500 rpm	155 Nm at 4000 rpm
Engine management	Bosch Motronic MED 7.5.11	Bosch Motronic MED 9.5.10
Fuel	Super unleaded at RON 98 (unleaded at RON 95 with reduction in performance)	
Exhaust gas treatment	Three-way catalyst with Lambda control, NO <sub>x</sub> storage catalytic converter	
Emissions standard	EU4	

# Engine mechanics

## Engine cover

Integrated in the engine cover:

- Air guide to throttle valve control unit
- Hot air regulator
- Intake noise insulation
- Air cleaner
- Intake air temperature sender 2 G299

## Engine cover, underside

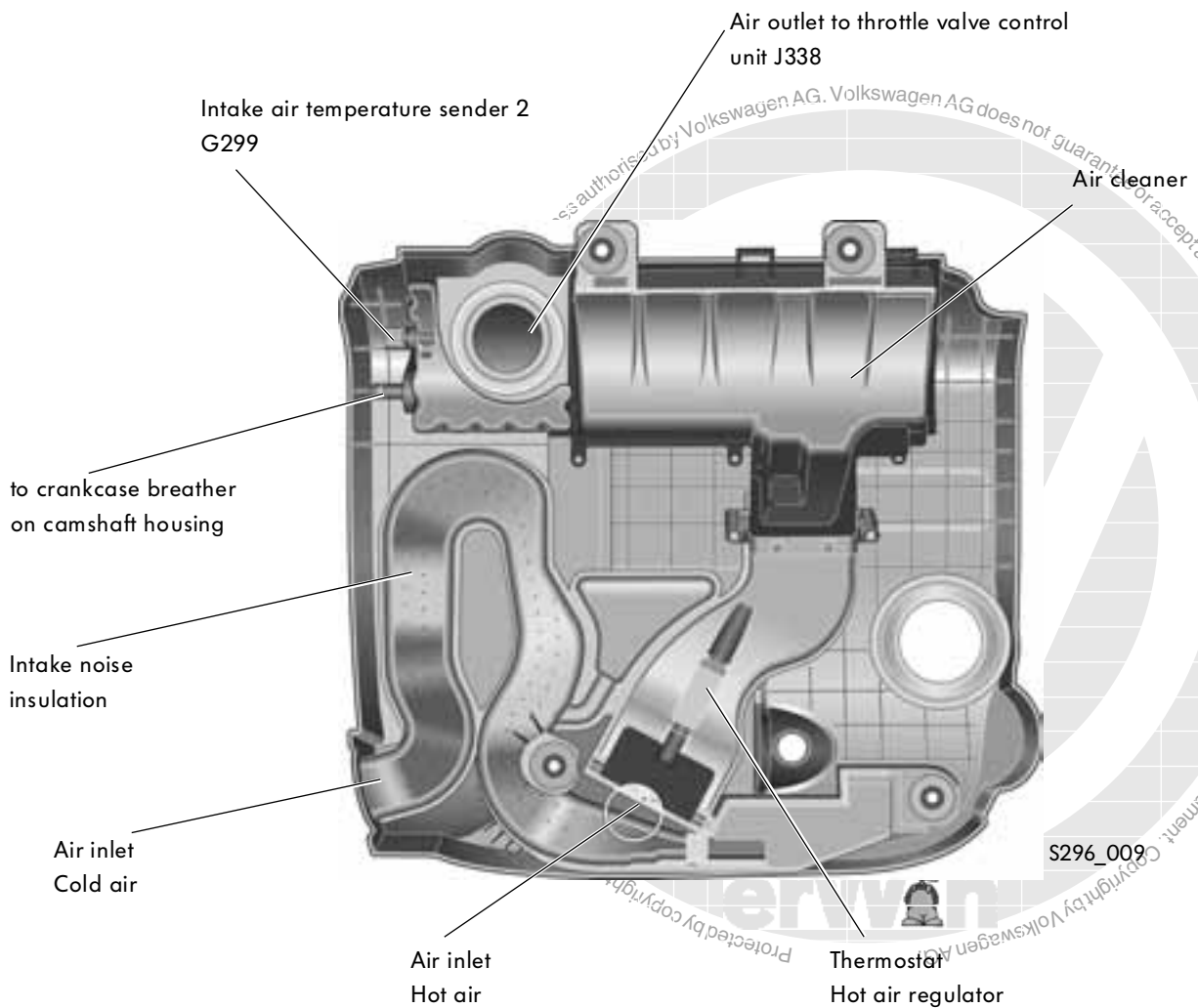

## Intake manifold upper part

The intake manifold upper part is made of plastic.

This has the following advantages:

- Reduction in weight
- Air flow improvement thanks to smoother intake walls

In the intake manifold upper part there is a vacuum unit that assures actuation of the intake manifold flaps even when vacuum pressure is low.

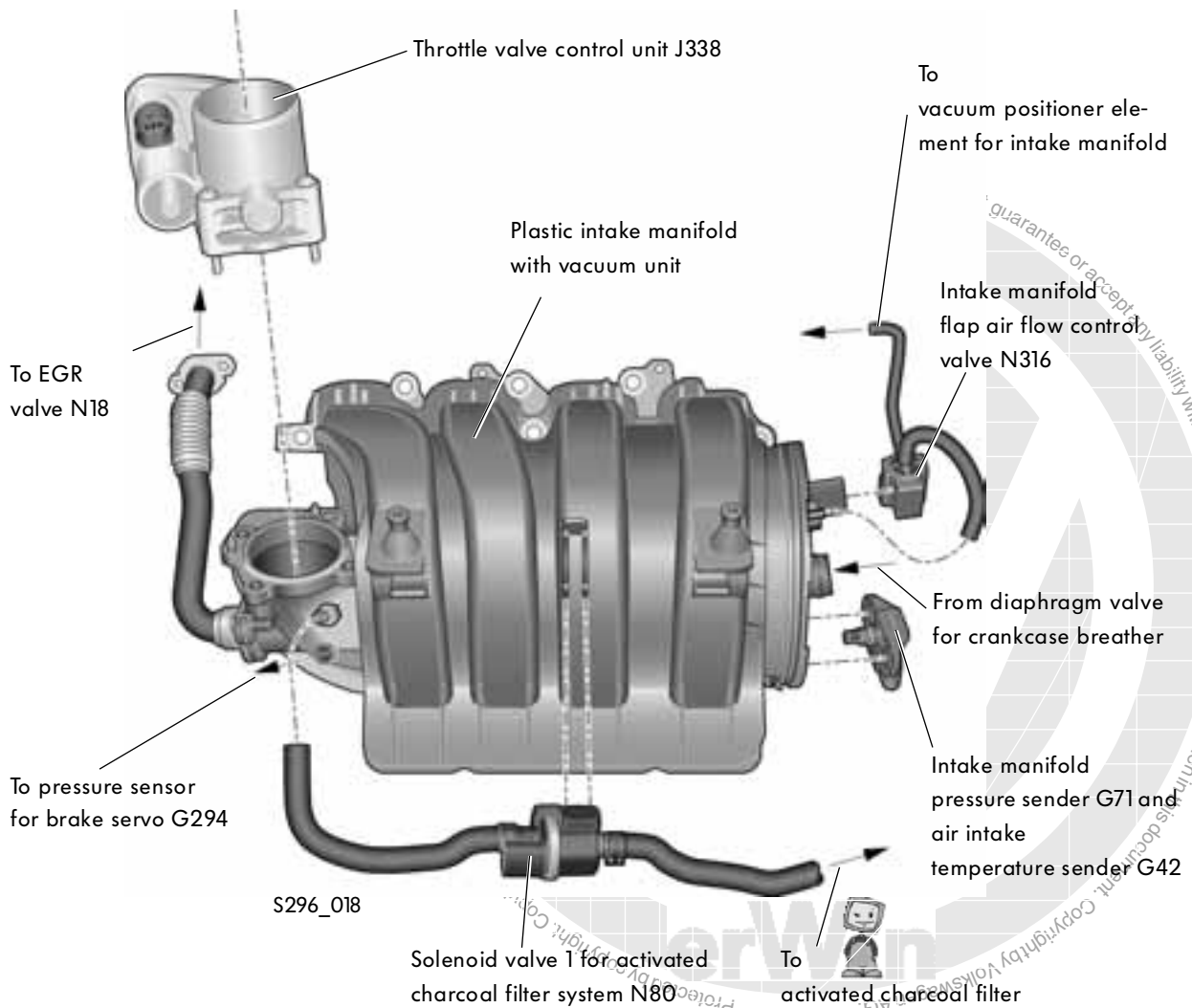

# Engine mechanics

## Control housing seal

The control housing is sealed to the cylinder head and the cylinder block by a bonded rubber gasket. Between the control housing and the oil sump there is a fluid gasket.

### Oil filter housing

The oil filter housing is integrated in the control housing. This means that there is no requirement for a sealing surface between the cylinder block and the oil filter housing.

### Cross section of bonded rubber gasket

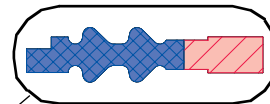

S296\_003

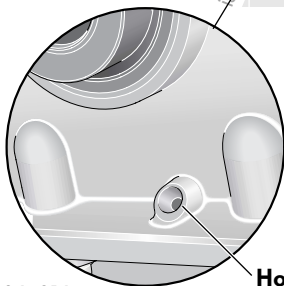
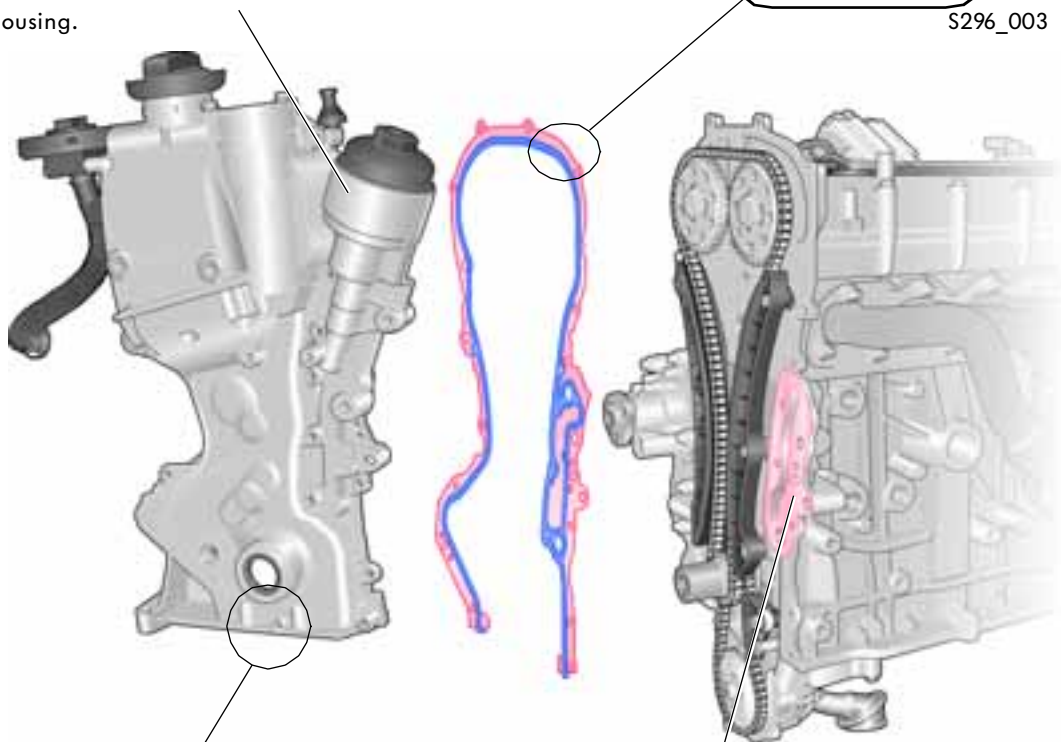

S296\_016

### Holes for the fluid gasket

### Fluid gasket

The seal between the control housing and the oil sump is made by a fluid gasket. This is pressed between the sealing surfaces by means of a special drilling in the control housing.

### Engine oil cross-over area

For transference of engine oil from the cylinder block into the control housing, there is an oil pressure of approx. 3.5 bar. Therefore, a bonded rubber gasket is used.

S296\_017

## Electric exhaust gas recirculation valve

The electric exhaust gas recirculation valve with EGR valve N18 and the potentiometer for exhaust gas recirculation G212 are bolted to the cylinder head.

The valve is designed for treatment of high levels of exhaust gas and draws the exhaust gas directly from the 4th cylinder of the cylinder head.

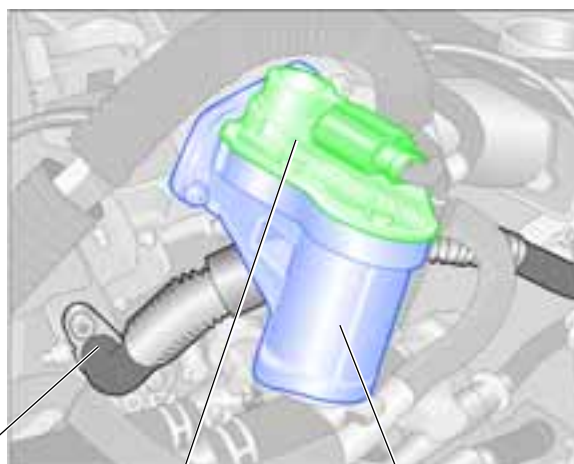

Withdrawal at cylinder no. 4

Potentiometer for exhaust gas recirculation G212

Exhaust gas recirculation valve N18

S296\_036

## Electric exhaust gas recirculation valve in the coolant circuit

Due to the vicinity of the exhaust gas withdrawal point, the exhaust gas recirculation valve is integrated in the coolant circuit of the engine. This allows the exhaust gas recirculation valve to be cooled and protected from excessively high temperatures.

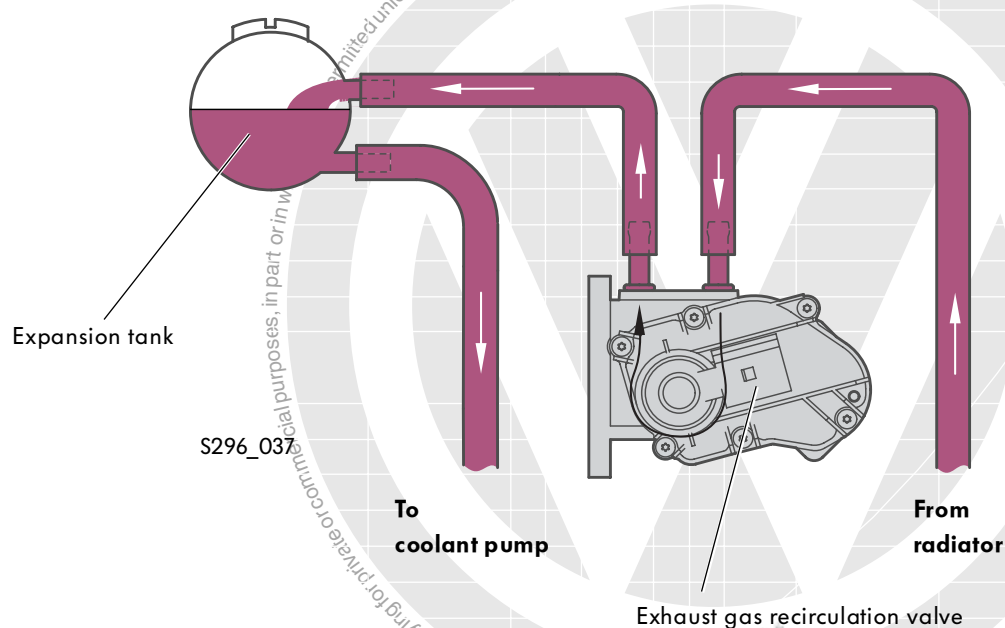

# Engine mechanics

## Cooling system

The cooling system is of a dual circuit design. This system features a separate coolant path, with different temperatures, through the cylinder block and the cylinder head. The coolant flow is controlled by two thermostats in the coolant distribution housing. One for the cylinder block and one for the cylinder head. Furthermore, both engines feature cross flow cooling of the cylinder head.

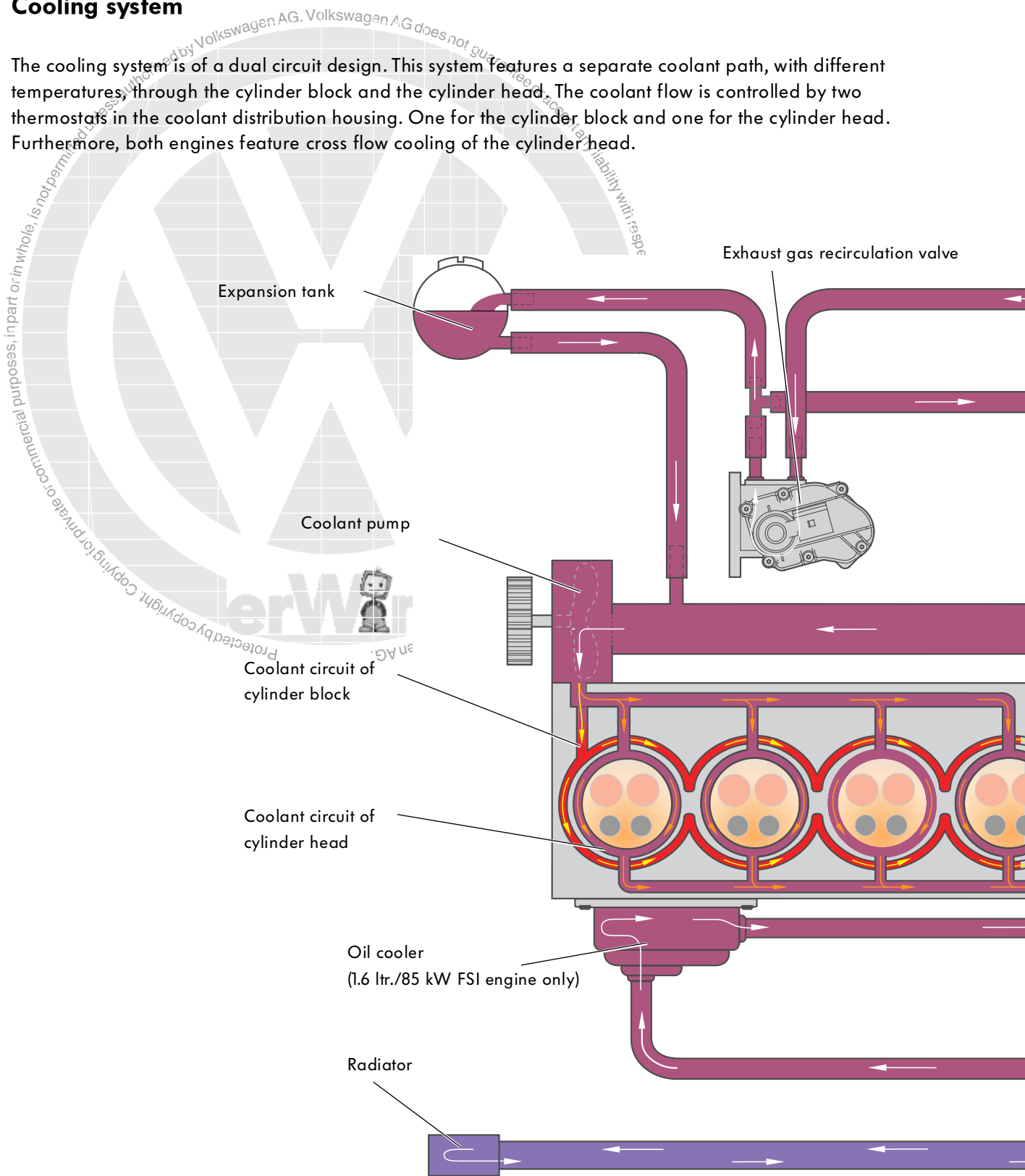

The dual circuit cooling system has the following advantages:

- The cylinder block is heated up faster because the coolant stays in the cylinder block until it reaches 105° C.
- There is less friction in the crankcase drive system due to higher temperatures in the cylinder block.
- There is improved cooling in the combustion chambers thanks to lower temperatures in the cylinder head. This leads to improved filling with less risk of knocking.

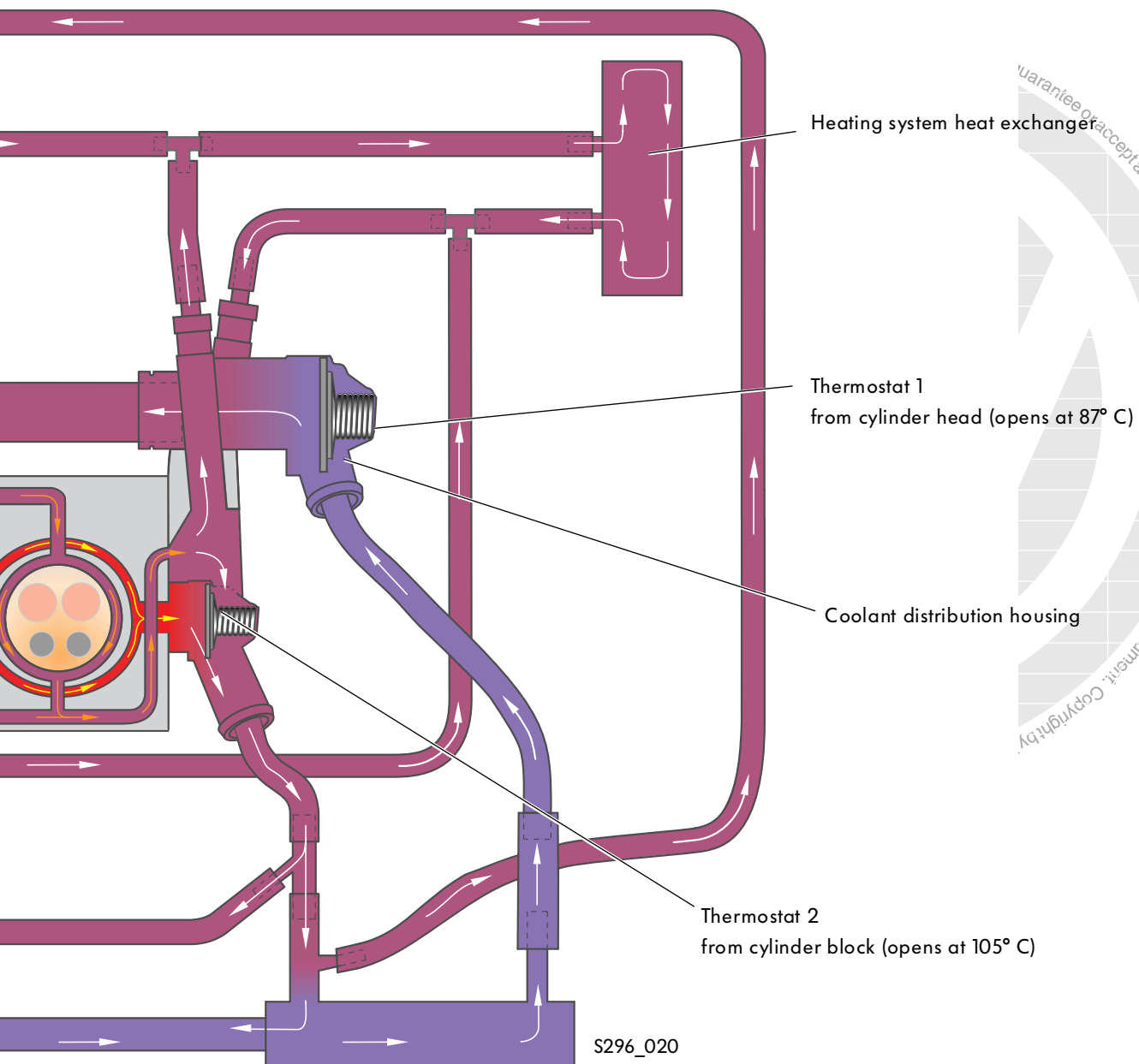

Warranty or accept any liability with respect to the correctness of information in this document. Copyright by

# Engine mechanics

## Dual circuit cooling system

The cooling system is split into two circuits in the engine. A third of the coolant in the engine flows to the cylinders and two thirds to the combustion chambers in the cylinder head.

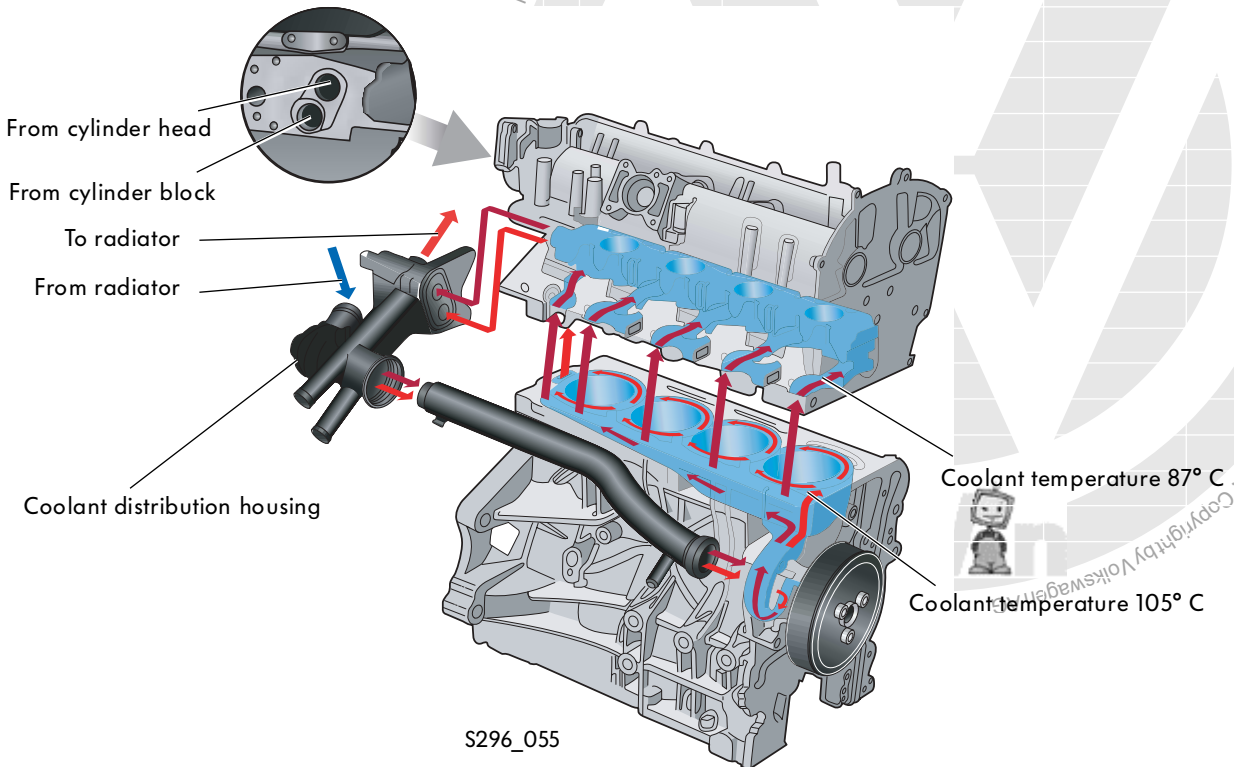

### Position of thermostats up to 87° C:

Both thermostats are closed, which means the engine is heated up faster.

The coolant flows through the following components:

- Coolant pump
- Cylinder head
- Coolant distribution housing
- Heating system heat exchanger
- Oil cooler  
(1.6 ltr./85 kW FSI engine only)
- Exhaust gas recirculation valve
- Expansion tank

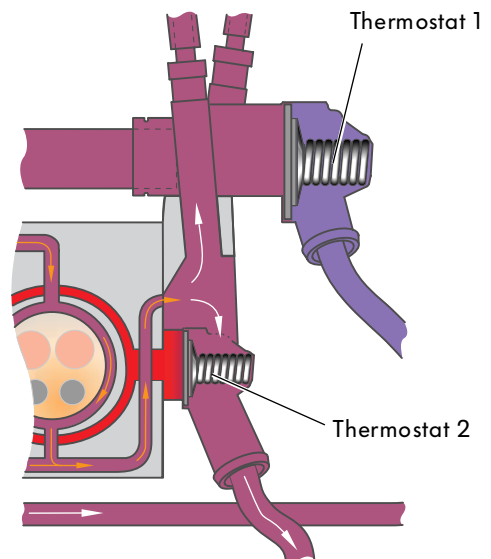

### Position of thermostats from 87° C to 105° C:

Thermostat 1 is open and thermostat 2 is closed. This regulates the temperature in the cylinder head to 87° C and increases the temperature in the cylinder block further.

The coolant flows through the following components:

- Coolant pump
- Cylinder head
- Coolant distribution housing
- Heating system heat exchanger
- Oil cooler  
(1.6 ltr./85 kW FSI engine only)
- Exhaust gas recirculation valve
- Expansion tank
- **Radiator**

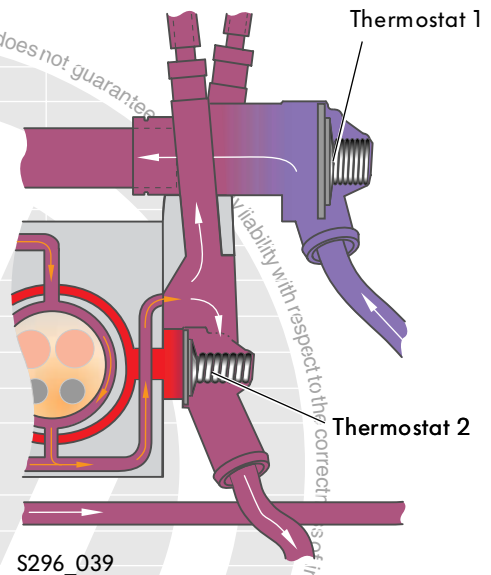

### Position of thermostats above 105° C:

Both thermostats are open. This regulates the temperature in the cylinder head to 87° C and in the cylinder block to 105° C.

The coolant flows through the following components:

- Coolant pump
- Cylinder head
- Coolant distributor
- Heating system heat exchanger
- Oil cooler  
(1.6 ltr./85 kW FSI engine only)
- Exhaust gas recirculation valve
- Expansion tank
- Radiator
- **Cylinder block**

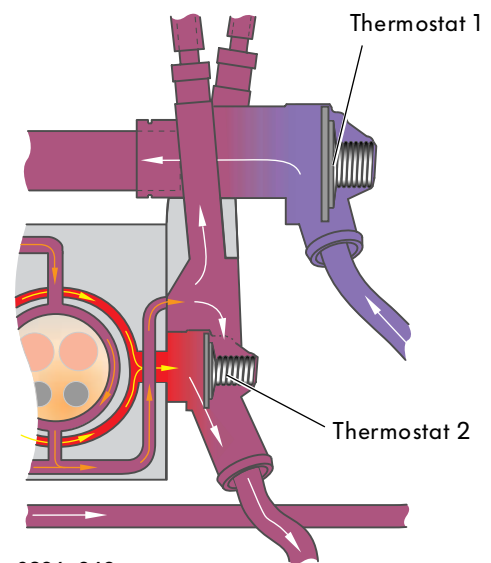

# Engine mechanics

## Regulated Duocentric oil pump

A regulated Duocentric oil pump is installed for the first time. Thanks to this equipment, oil pressure is regulated to approx. 3.5 bar across almost the entire rev range. Regulation is by means of a control ring and control spring.

This provides the following advantages:

- The drive performance of the oil pump is reduced by up to 30 %.
- Wear in the oil is reduced because less oil is being circulated.
- The build up of oil foam in the oil pump is minimised as oil pressure remains constant across almost the entire rev range.

In the adjacent diagram you can see the individual parts of the regulated oil pump.

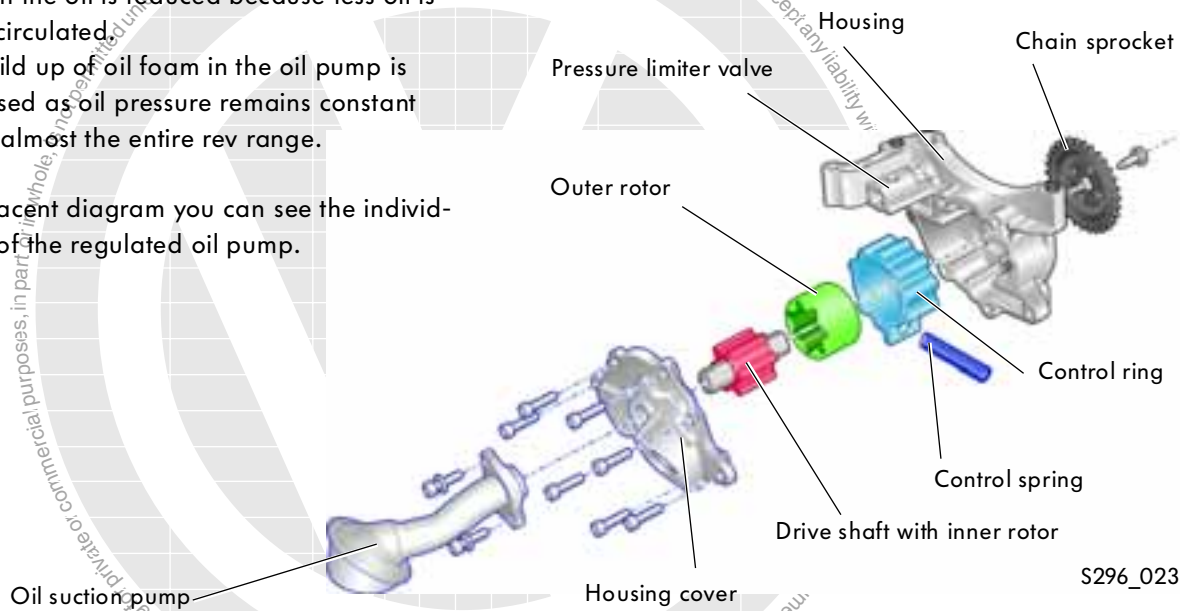

S296\_023

### Drive of regulated oil pump

The oil pump is bolted to the underside of the cylinder block and is chain driven from the crankshaft. The chain is maintenance-free. The chain is tensioned by means of a steel spring on the chain tensioner.

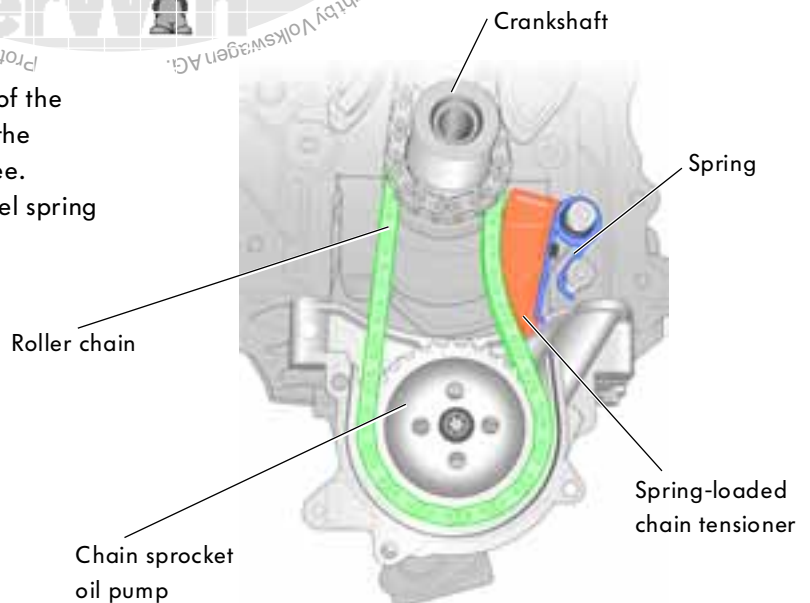

S296\_013

## Principle of oil delivery

The inner rotor sits on the drive shaft and drives the outer rotor. Due to the different rotating axes of the inner and outer rotors, a larger space is created on the suction side due to the rotating motion. The oil is drawn in and transported to the pressure side. On the pressure side, the space between the teeth becomes smaller again and oil is forced into the oil circuit.

## Regulation of oil pressure

On the regulated Duocentric oil pump, oil pressure is regulated at 3.5 bar in the amount of oil delivered.

### Oil pressure below 3.5 bar

The control spring forces the control ring against the oil pressure (arrows). The control ring also causes the outer rotor to turn and an increase in space between inner and outer rotors is the result. This means that more oil is transported from the suction side to the pressure side and forced into the oil circuit. With a greater amount of oil, there is also greater oil pressure.

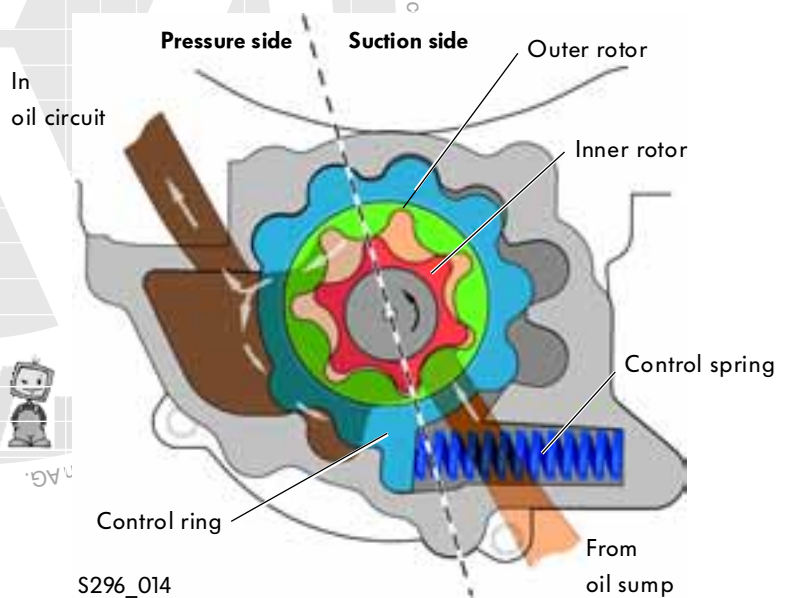

### Oil pressure above 3.5 bar

The oil pressure (arrows) forces the control ring against the control spring. The outer rotor is also turned in the direction of the arrow and a decrease in space between the inner and outer rotors is the result. This means that less oil is transported from the suction side to the pressure side and forced into the oil circuit. With a reduced amount of oil, there is less oil pressure.

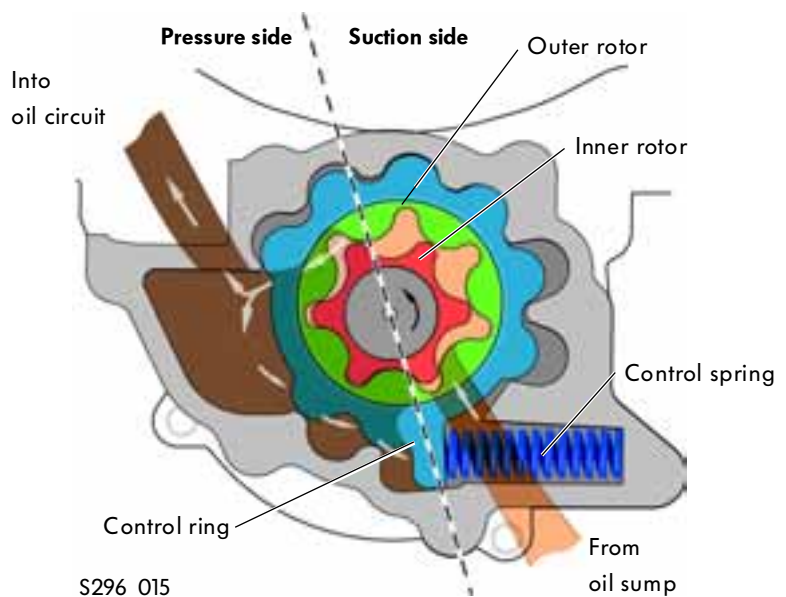

# Engine mechanics

## Variable valve timing (1.6 ltr./85 kW FSI engine)

The 1.6 ltr./85 kW FSI engine has variable inlet valve timing. Adjustment of the camshaft is load and speed dependent and comes from a vane cell adjuster attached directly to the inlet camshaft.

Variable valve timing leads to:

- very effective inner exhaust gas recirculation, whereby combustion temperature and nitrogen oxides are reduced, and
- also improved torque development.

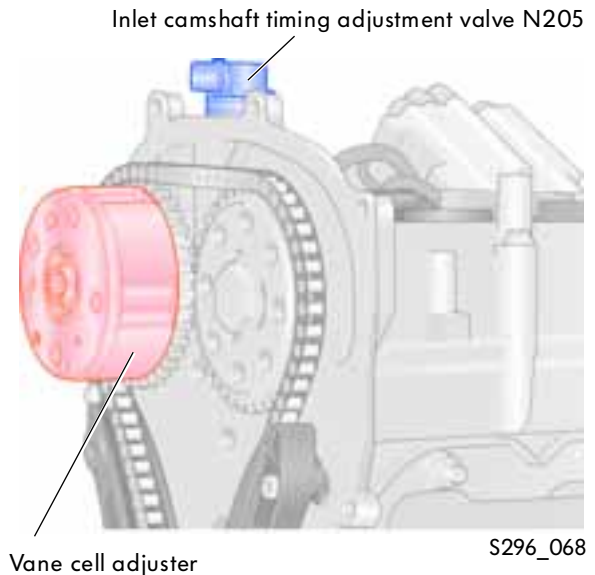

The central securing bolt of the vane cell adjuster has a left-handed thread.

### Vane cell adjuster

The vane cell adjuster is bolted to the timing control side of the inlet camshaft.

The adjustment range covers a maximum 40° crankshaft angle and a 20° camshaft angle, starting from the basic position towards "advanced".

The advantages of the vane cell adjuster as opposed to the camshaft adjuster of the 1.4 ltr./77 kW FSI are:

- Adjustment is possible even at low oil pressures
- It is easier
- It is cheaper

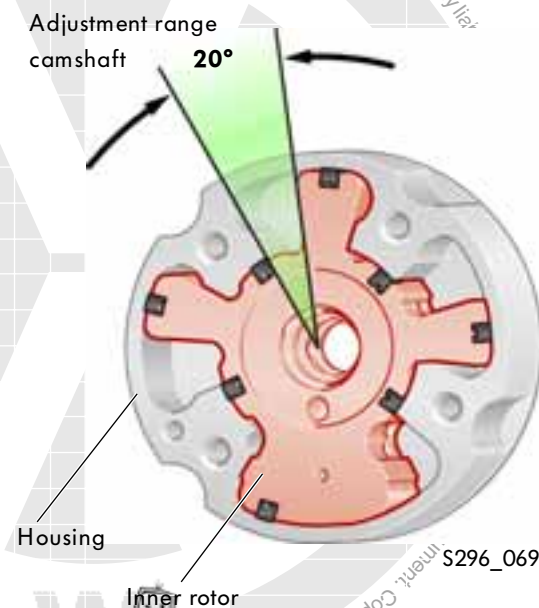

Further information about this principle of variable valve timing can be found in self-study programme number 246 "Variable valve timing with the vane cell adjuster".

## Inlet camshaft timing adjustment valve N205

This can be found in the camshaft housing and is included in the oil circuit of the engine.

Actuation of the inlet camshaft timing adjustment valve results in oil being fed to one or both oil channels.

Depending on which oil channel is accessible, the inner rotor is adjusted in the direction of "advanced" or "retarded", or held in its position. As the inner rotor is bolted to the inlet camshaft, the camshaft is adjusted in the same way.

### Effects of failure

If the inlet camshaft timing adjustment valve N205 fails in its function, there is no variable timing adjustment.

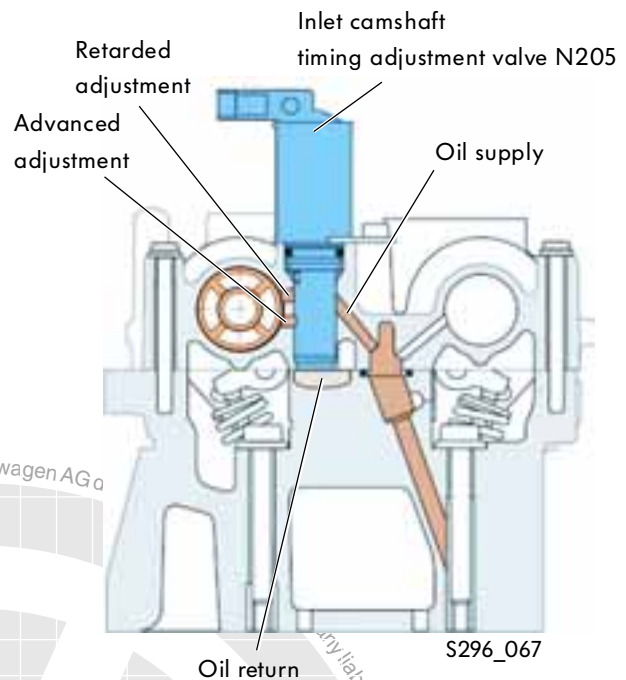

### Oil cooler

Due to the higher rev range of the 1.6 ltr./85 kW FSI engine, the engine oil is subjected to greater heat. To guarantee precise adjustment of the inlet camshaft across the entire rev range, an oil cooler is installed.

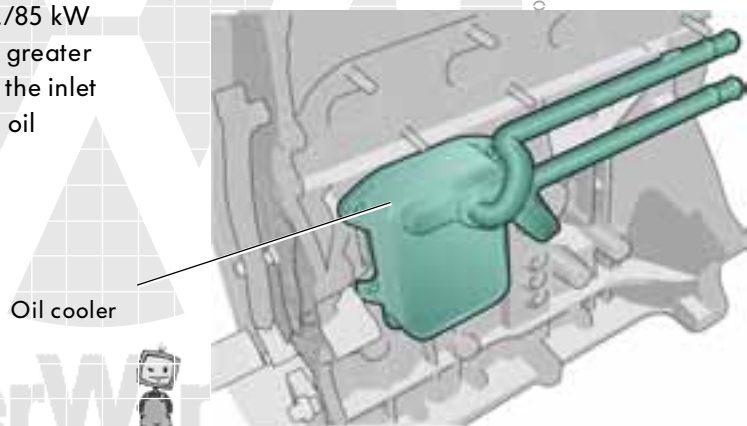

# Engine management

## System overview

- Inlet manifold pressure sender **G71**
- Intake air temperature sender **G42**
  
- Intake air temperature sender 2 **G299**
  
- Engine speed sender **G28**
  
- Hall sender **G40**
- Throttle valve control unit **J338**
- Throttle valve drive angle sender 1+2 **G187** and **G188**
  
- Accelerator pedal position sender **G79** and **G185**
  
- Clutch pedal switch **F36**
  
- Brake light switch **F** and brake pedal switch **F47**
  
- Fuel pressure sender, high pressure **G247**
  
- Fuel pressure sender, vacuum pressure **G410**
  
- Knock sensor **G61**
  
- Coolant temperature sender **G62**
- Coolant temperature sender - radiator outlet **G83**
  
- Potentiometer for intake manifold flap **G336**
- Potentiometer for exhaust gas recirculation **G212**
  
- Lambda probe **G39**
  
- Exhaust gas temperature sender **G235**
  
- NOx\* sender **G295**,  
NOx sensor\* control unit **J583**
  
- Brake servo pressure sensor **G294**
  
- Temperature selection potentiometer **G267**
  
- Additional input signals

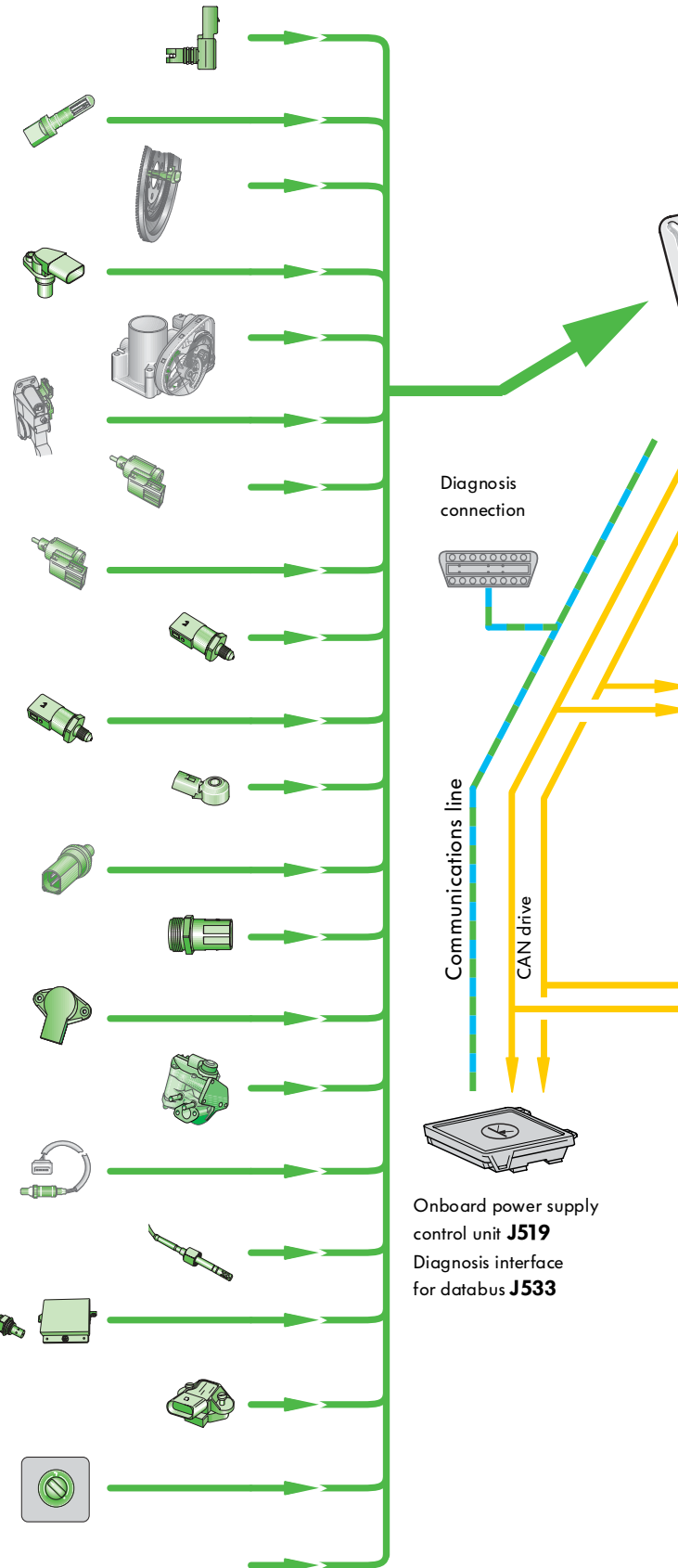

Copyright © 2015 Volkswagen Group of America. All rights reserved. Copying for private or commercial purposes, in part or in whole, is not permitted unless authorized by Volkswagen.



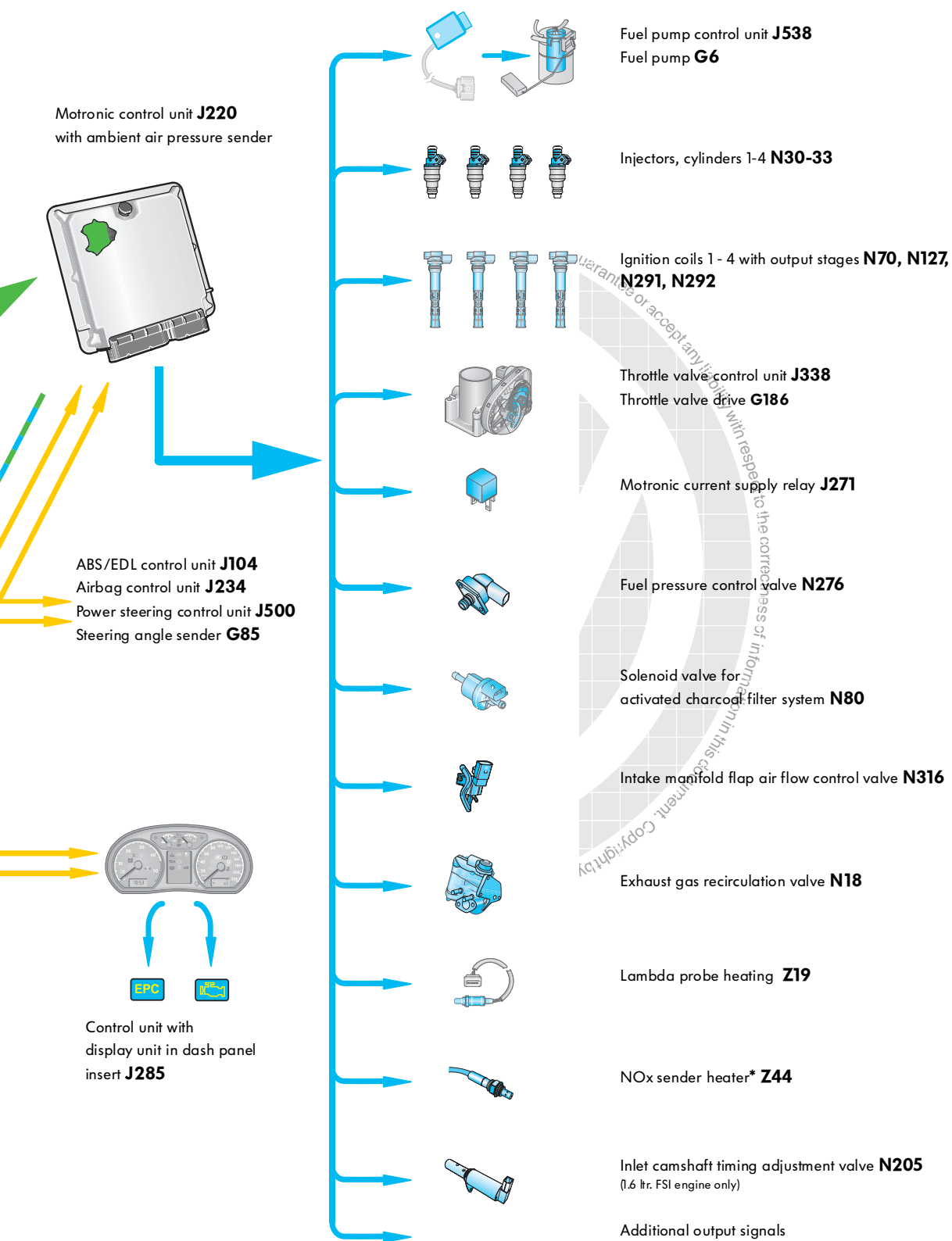

Warranty or accept any liability with respect to the correctness of information in this document. Copyright by

# Engine management

## Engine control unit J220 (1.4 ltr./63 kW FSI engine)

The engine control unit on the Polo can be found on the bulkhead in the engine compartment and has 121 pins.

The installation location was carefully selected to allow easy access but also to protect against dampness.

The torque-based engine management system is Bosch Motronic MED 7.5.11. In the housing of the control unit there is also an ambient air pressure sender.

The engine control unit calculates and controls the optimum fuel and air mixture for the following modes of operation.

- Stratified injection
- Homogeneous-lean
- Homogeneous
- Double injection, catalyst warm-up



Engine control unit with ambient air pressure sender J220

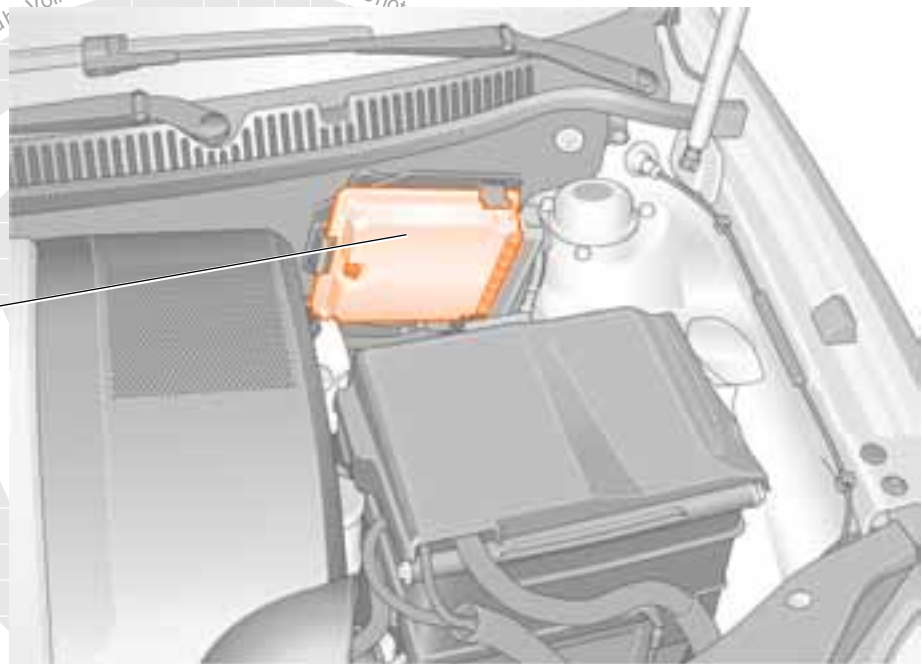

S296\_025

The designation **MED 7.5.11** stands for:

**M** =Motronic

**E** =Electric throttle operation

**D** =Direct injection

**7.** =Version

**5.11** =Development stage

## Engine control unit J220 (1.6 ltr./85 kW FSI engine)

The engine control unit on the Touran can be found in the plenum chamber and has 154 pins.

The torque-based engine management system is Bosch Motronic MED 9.5.10.

The engine control unit calculates and controls the optimum fuel and air mixture for the following modes of operation.

- Stratified injection
- Homogeneous-lean
- Homogeneous
- Double injection, catalyst warm-up
- Double injection, full throttle

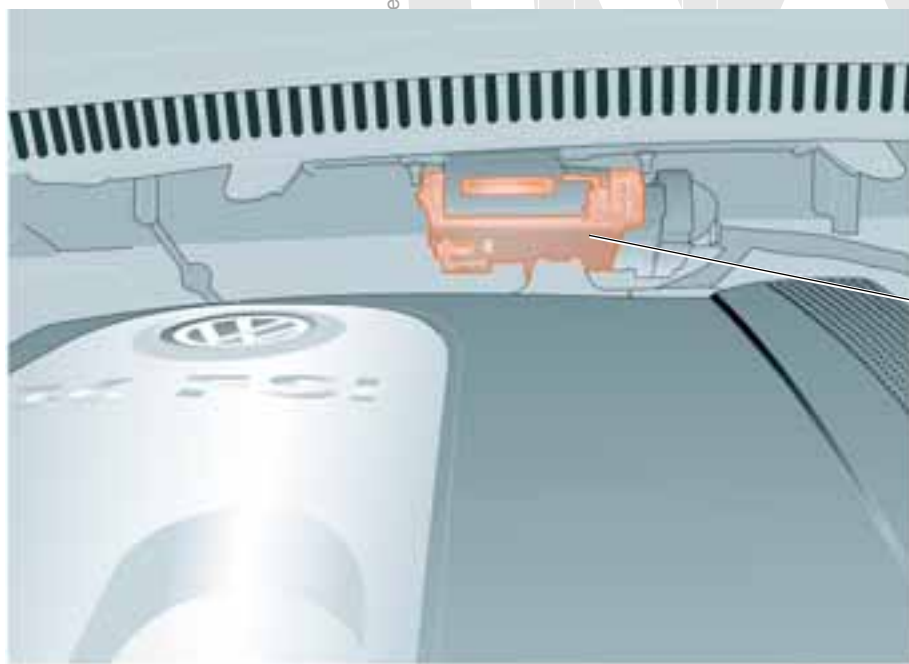

Engine control unit with ambient air pressure sender J220

S296\_056

The designation MED 9.5.10 stands for:

**M** =Motronic

**E** =Electric throttle operation

**D** =Direct injection

**9.** =Version

**5.10** =Development stage



# Engine management

## Operating types

In addition to the operating types stratified injection, homogeneous-lean and homogeneous, there are two further operating modes. These are 'double injection, catalyst warm-up' and 'double injection, full throttle'. Thanks to these two modes, firstly, the catalyst is warmed up faster and, secondly, torque is increased in the lower rev range.

### Double injection, catalyst warm-up

In homogeneous catalyst warm-up mode, the catalyst is warmed up faster and it therefore reaches its optimal operating temperature earlier. Furthermore, quieter running is the result and there are fewer HC emissions. All in all, there is a reduction in exhaust emissions and fuel consumption.

### First injection

The first injection is when the crankshaft angle is at approx.  $300^\circ$  before TDC during the intake stroke. This helps to achieve a balanced distribution of the air and fuel mixture.

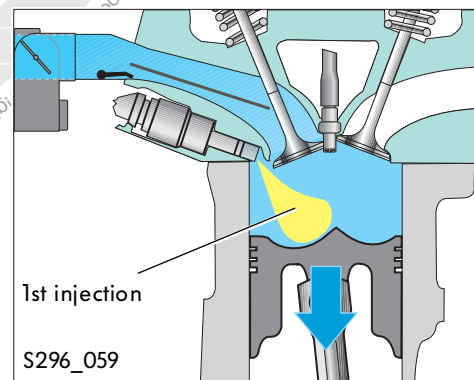

### Second injection

During the second injection, a small amount of fuel is injected when the crankshaft angle is at approx.  $60^\circ$  before TDC. This mixture burns very late and exhaust gas temperature increases.

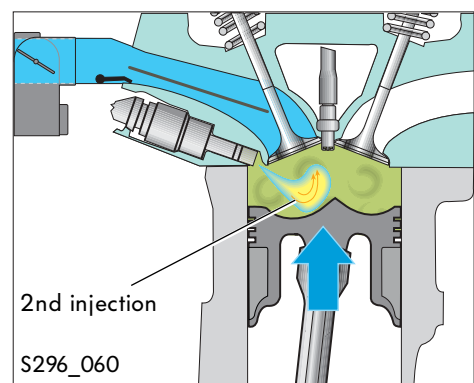

The warmer exhaust gas heats up the catalyst, which allows it to reach its optimal operating temperature.

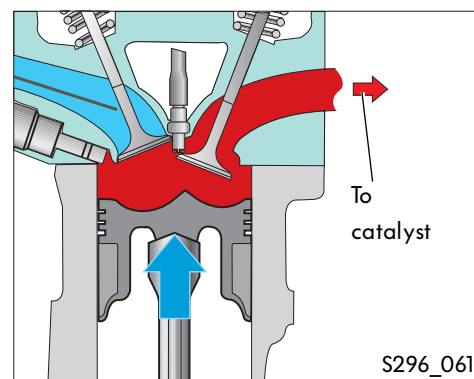

## Double injection, fullthrottle (1.6 ltr./85 kW FSI engine)

On petrol direct injection systems, there are times when the fuel and air mixture is unfavourable at engine speeds up to 3000 rpm and at full throttle. Thanks to double injection, this is avoided and torque is increased by 1-3 Nm.

### The first injection

The first injection happens when the crankshaft angle is at approx. 300° before TDC during the intake stroke. Here, approx. two thirds of the total amount is injected.

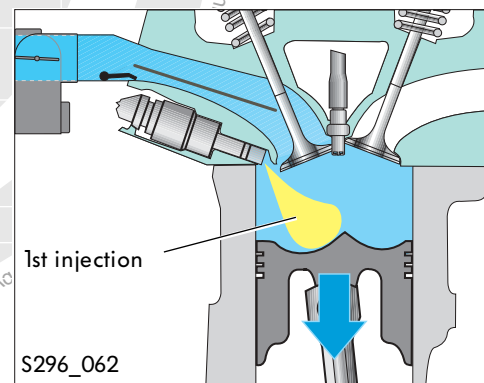

### The second injection

The remaining amount of fuel, approx. one third, is injected at about the start of the compression stroke. In this way, less fuel is built up on the cylinder wall. The fuel evaporates almost completely and mixture distribution is improved. Furthermore, there is also a richer mixture in the area of the spark plug compared to the rest of the combustion chamber. This improves combustion and reduces the risk of knocking.

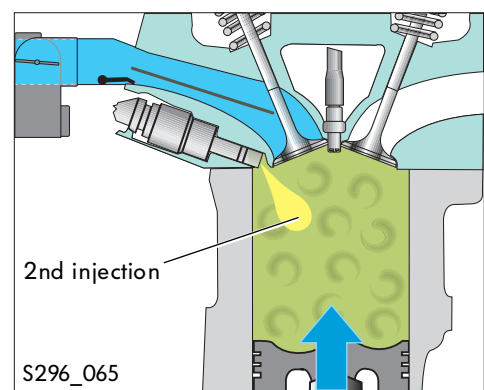

# Engine management

## Intake system

The intake system has been changed, compared to the Bosch Motronic MED 7.5.10 system, as far as engine load detection is concerned. The hot film air mass meter G70 has been discontinued. For calculation of the engine load, use is made of intake air temperature sender 2 G299 in the engine cover and the ambient air pressure sender in the engine control unit.

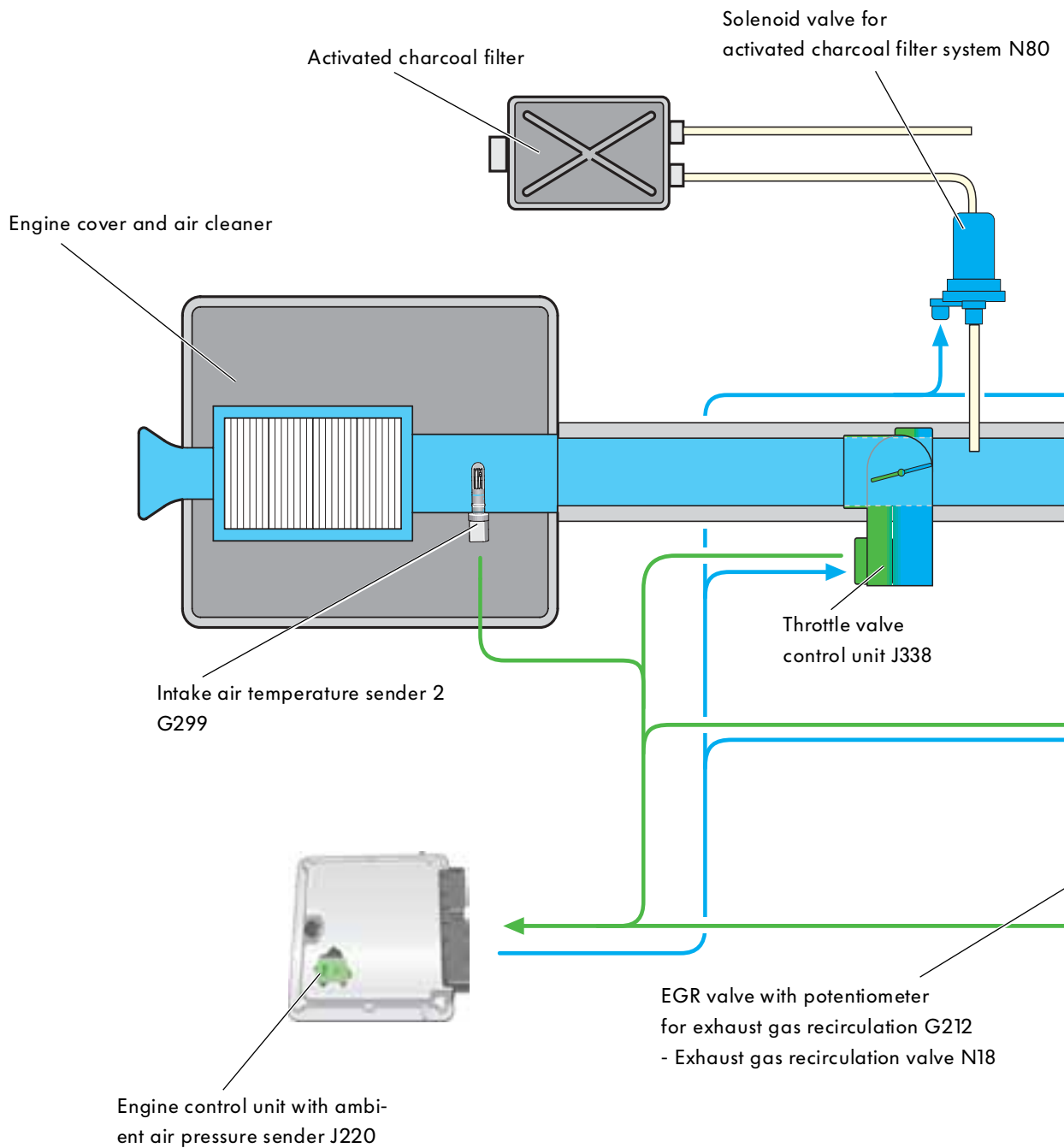

... does not guarantee or accept any liability with respect to the correctness  
... part or in whole, is not permitted unless authorised by Volkswagen AG.

Intake manifold flap air  
flow control valve N316

Intake manifold flap vacuum unit

Intake manifold flap  
potentiometer G336

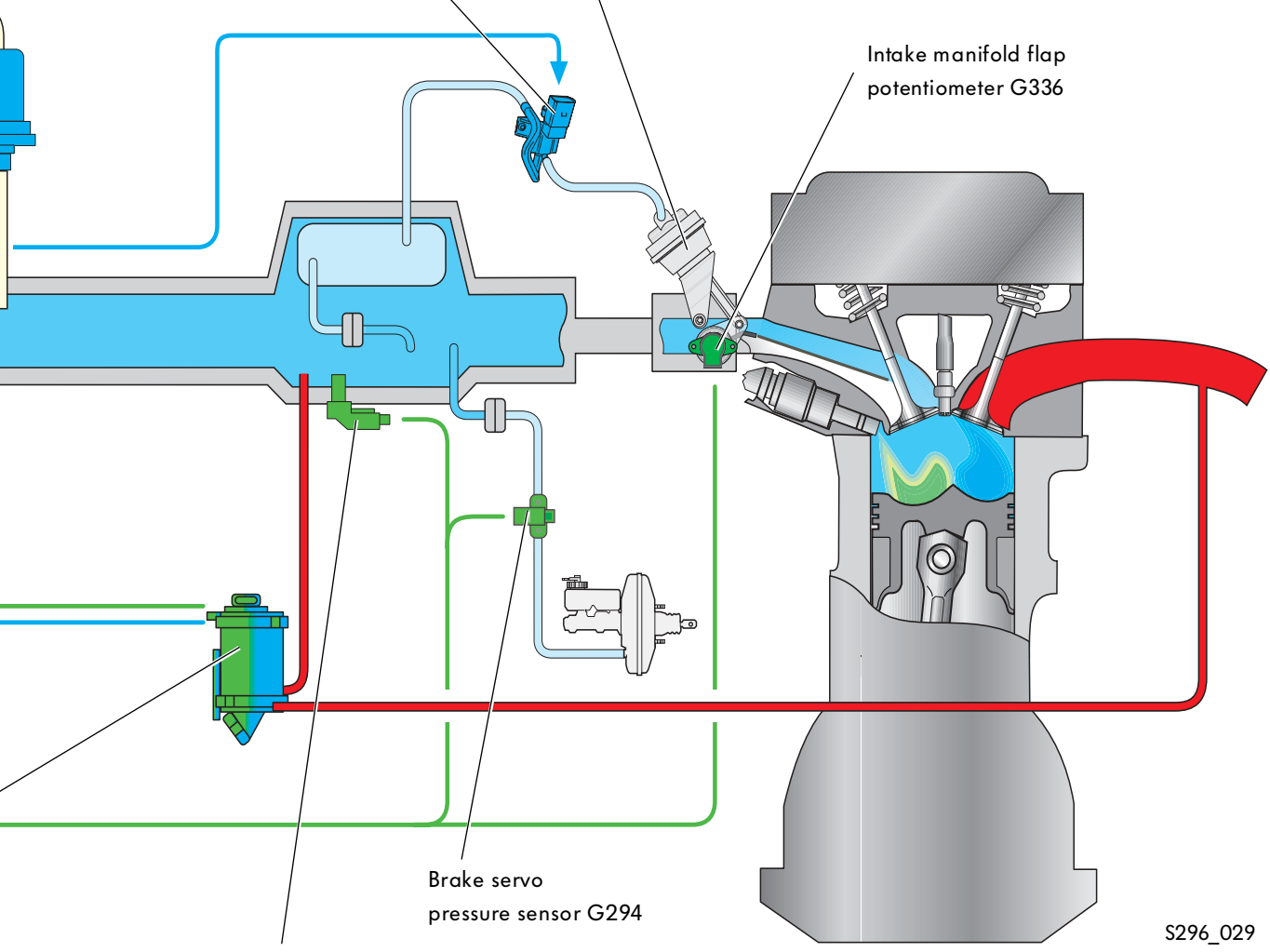

Brake servo  
pressure sensor G294

Intake manifold pressure sender G71  
with intake air temperature sender G42

S296\_029



# Engine management

## Engine load detection

On FSI engines, engine load was previously measured using a hot film air mass meter. It is now calculated by the engine control unit as the hot film air mass meter has been discontinued. In place of this component, there is now an air intake temperature sender and an ambient air pressure sender.

**Engine load is calculated from the following signals:**

- Intake air temperature sender 2 G299
- Ambient air pressure sender (in engine control unit) J220
- Intake manifold pressure sender G71
- Intake air temperature sender G42
- Engine speed sender G28
- Throttle valve drive angle sender 1+2 G187 and G188
- Intake manifold flap air flow control potentiometer G336
- Hall sender G40 (for position of inlet camshaft on 1.6 ltr./85 kW FSI engine)

## Intake air temperature sender 2 G299

The sender is installed in the engine cover in front of the throttle valve control unit.

### Signal application

It detects the temperature of the fresh air drawn in and passes on this information to the engine control unit.

This then calculates the density of the fresh air.

### Ambient air pressure sender

The sender is part of the engine control unit.

### Signal application

It measures ambient air pressure and passes on a relevant signal to the engine control unit. This then detects the pressure at the throttle valve control unit.

### Effects of signal failure

If one or both of the senders fail in their function, emergency running mode is selected, engine load is calculated by the engine control unit using stored values.

S296\_010

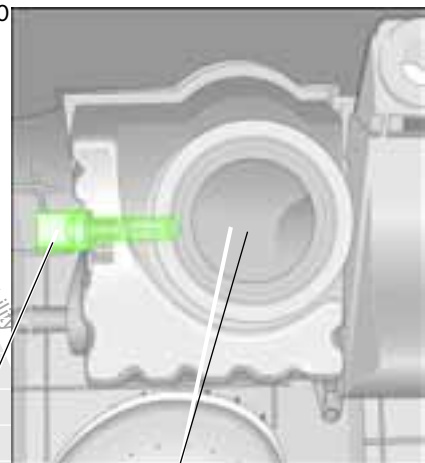

Intake air temperature sender 2 G299

Air outlet to throttle valve control unit

S296\_026

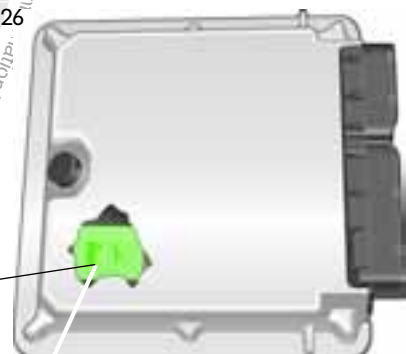

Ambient pressure sender

## Amount of exhaust gas recirculation

On FSI engines, a high amount of exhaust gas recirculation is necessary to reduce nitrogen oxide emissions. In order that the amount of exhaust gas can be pushed up to its limit, it has to be calculated precisely.

**The following information is required for calculation of the amount of recirculated exhaust gas:**

- Intake manifold pressure sender G71
- Intake air temperature sender G42
- Ambient air pressure sender (in engine control unit) J220 (to calculate counter pressure of exhaust gas)
- Exhaust gas temperature sender 1 G235
- The calculated engine load

**This is how it works:**

If exhaust gas is recirculated, intake manifold volume is increased by the recirculated exhaust gas and intake manifold pressure increases. The intake manifold pressure sender detects this pressure increase and sends a relevant voltage signal to the engine control unit. From this signal, the total amount is calculated (fresh air + exhaust gas). It deducts this total amount from the mass of fresh air from the calculated engine load and is thus left with the amount of exhaust gas.

## Intake manifold pressure sender G71, intake air temperature sender G42

This combined sender is attached on the right (from seated driver's perspective) of the plastic intake manifold.

### Signal application

It calculates the pressure and the temperature in the intake manifold and passes on a relevant signal to the engine control unit that, in turn, calculates the intake manifold volume.

### Effects of signal failure

If one of the senders should fail in its function, the amount of exhaust gas is calculated by the engine control unit and the amount of recirculated exhaust gas is reduced based on the map.

S296\_021

Intake manifold pressure sender G71

Intake air temperature sender G42



# Engine management

## Supply on demand fuel system

The supply on demand fuel system is a further development of the 1.4 ltr./77 kW FSI engine. The electric fuel pump supplies only the correct amount of fuel required by the high pressure fuel pump. In this way, power drawn by the pump is reduced and fuel consumption is reduced.

### Low pressure fuel system

In the low pressure fuel system, fuel pressure is at 4 bar during normal operation. For hot and cold starting, the pressure is increased to 5 bar.



#### It consists of the:

- Fuel pump control unit J538
- Fuel tank
- Electric fuel pump G6
- Fuel filter
- Fuel pressure sender, low pressure G410



If the engine control unit or the electric fuel pump are renewed, adaption of the new parts must be carried out. To do this, refer to the notes displayed during "Guided fault finding" on VAS 5051.

#### Colour codes/key

-  No pressure
-  4 to 5 bar
-  50 to 100 bar

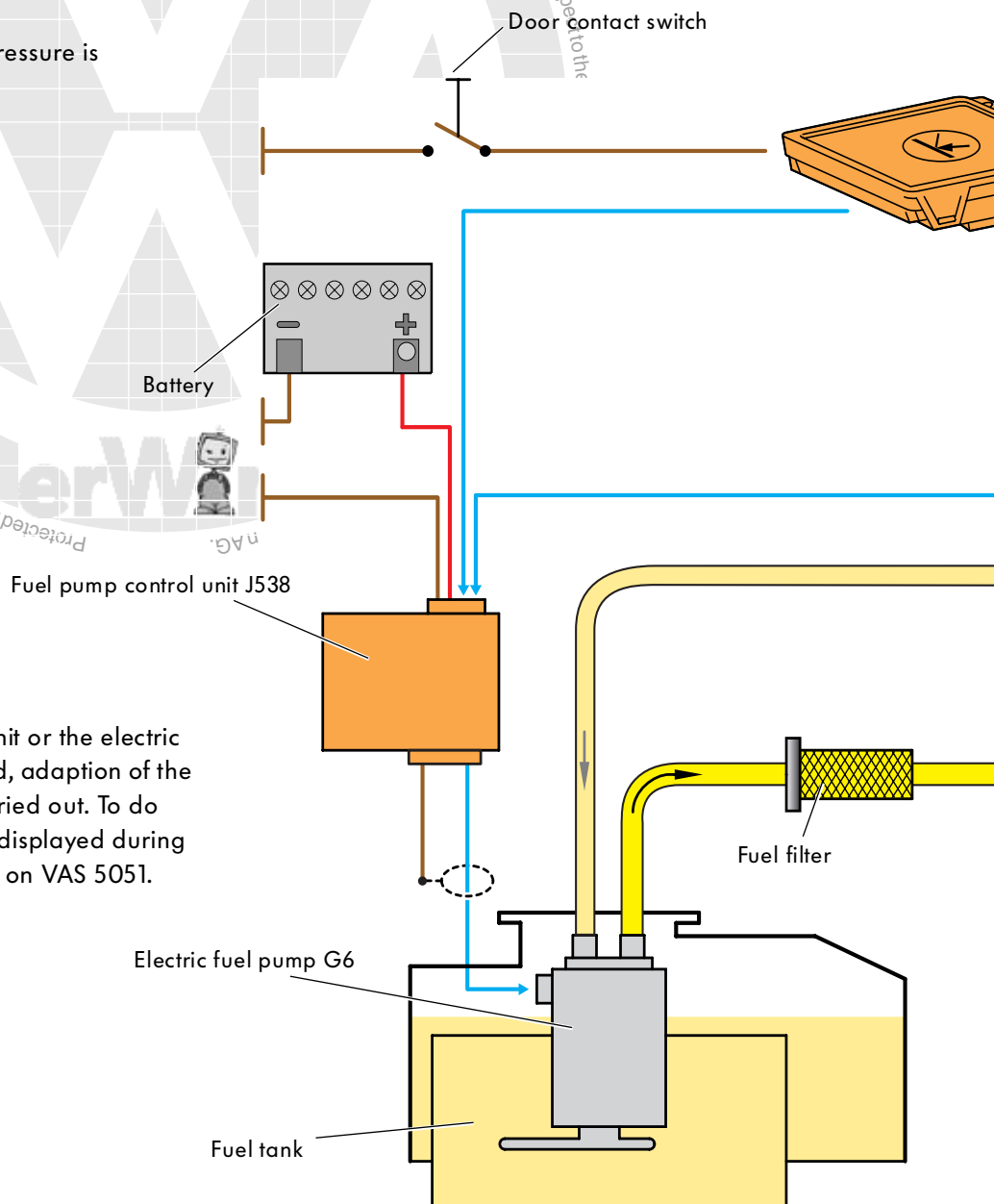

## High pressure fuel system

In the high pressure fuel system, fuel pressure is between 50 and 100 bar.

### It consists of the:

- High pressure fuel pump
- Fuel pressure control valve N276
- High pressure fuel line
- Fuel rail
- Pressure limiter valve
- Fuel pressure sender, high pressure G247
- High pressure injectors N30-N33

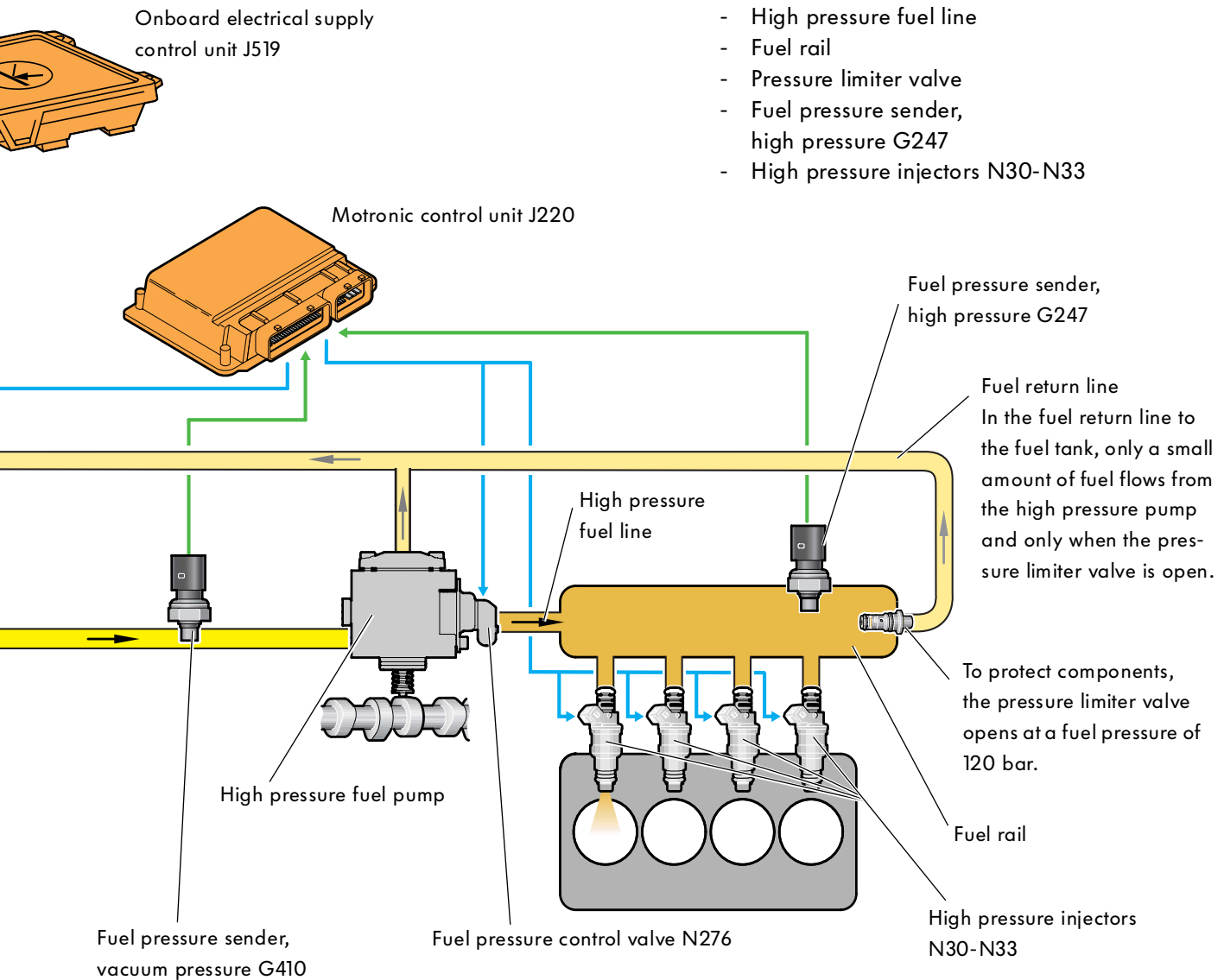

# Engine management

## Fuel pump control valve J538

The control unit can be found under the rear bench seat in the cover of the electric fuel pump.

### Task

The control unit J538 actuates the electric fuel pump and regulates the pressure in the low pressure fuel system at a constant 4 bar. For hot and cold starting, the pressure is increased to 5 bar.

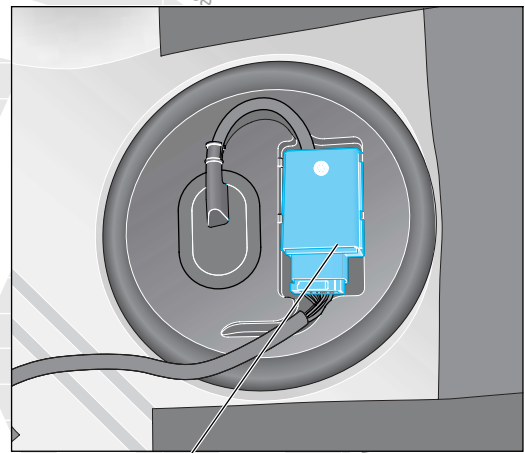

Fuel pump control valve J538

S296\_031

### Effects of signal failure

If the fuel pump control unit should fail in its function, the engine will not run.

### Terminal diagram

- G Fuel gauge sender
- G1 Fuel gauge sender
- G6 Fuel pump

- J220 Engine control unit
- J285 Control unit with display unit in dash panel insert
- J538 Control unit for fuel pump
- J519 Onboard electrical system control unit

The fuel gauge sender is supplied with earth from the control unit with display unit in dash panel insert J285.

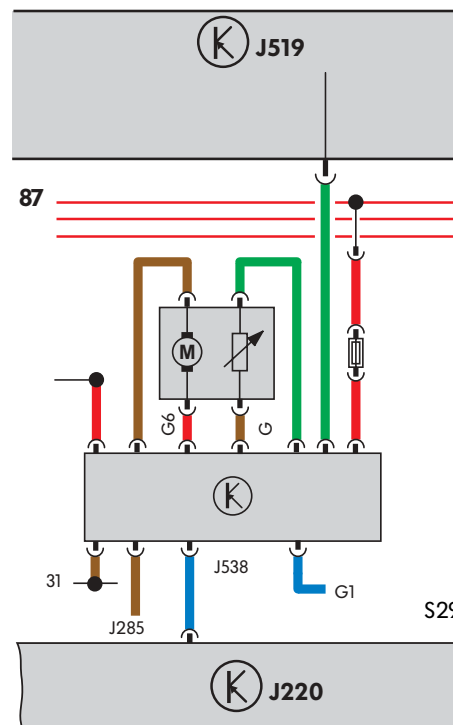

S296\_034

## Fuel pressure sender, vacuum pressure G410

The sender is installed in the presupply line to the high pressure pump. It measures fuel pressure in the low pressure fuel system and sends a signal to the engine control unit.

### Signal application

Use is made of this signal to regulate pressure in the low pressure fuel system.

- In normal operation to 4 bar and
- during cold and hot starting to 5 bar

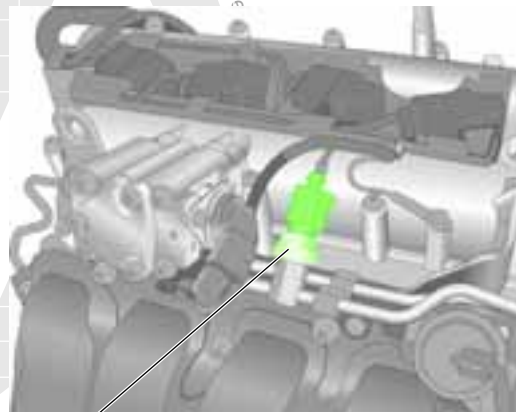

S296\_004

Fuel pressure sender, vacuum pressure G410

### Effects of signal failure

If the fuel pressure sender should fail in its function, the electric fuel pump will be actuated with a fixed PWM signal and the pressure in the low pressure fuel system is increased.

## Fuel pressure sender, high pressure G247

The sender can be found on the intake manifold lower part and is screwed on the fuel rail. It measures fuel pressure in the high pressure fuel system and sends the signal to the engine control unit.

### Signal application

The engine control unit evaluates the signals and, via the fuel pressure control valve, regulates the pressure in the fuel rail.

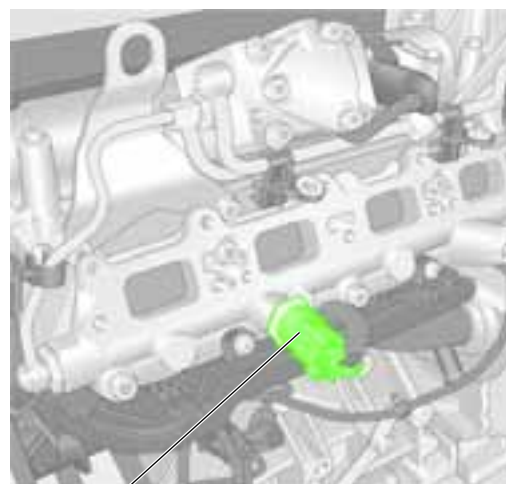

S296\_027

Fuel pressure sender, high pressure G247

### Effects of signal failure

If the fuel pressure sender should fail in its function, the control valve is actuated from the engine control unit with a fixed value.



# Engine management

## High pressure fuel pump

It is screwed into the camshaft housing and is operated by a double cam on the inlet camshaft.

It has the task of building up fuel pressure in the high pressure fuel system by up to 100 bar.

The component consists of a quantity-controlled single cylinder high pressure pump. It pumps just the required amount of fuel to the fuel rail depending on a map, and just the required amount of fuel for injection. In this way, the output of the high pressure pump is reduced, which contributes to a saving in fuel.

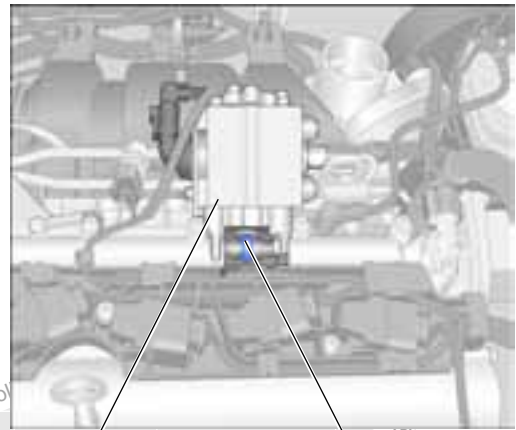

Single cylinder high pressure fuel pump

Double cams on the inlet camshaft

### Suction stroke function:

The pump plunger is moved down by means of the plunger spring. In this way, volume is increased in the pump chamber and pressure is decreased. As soon as the pressure in the low pressure fuel system is greater than the pressure in the pump chamber, the inlet valve will open and fuel will begin to flow. The outlet valve is closed because fuel pressure is greater in the fuel rail than in the pump chamber.

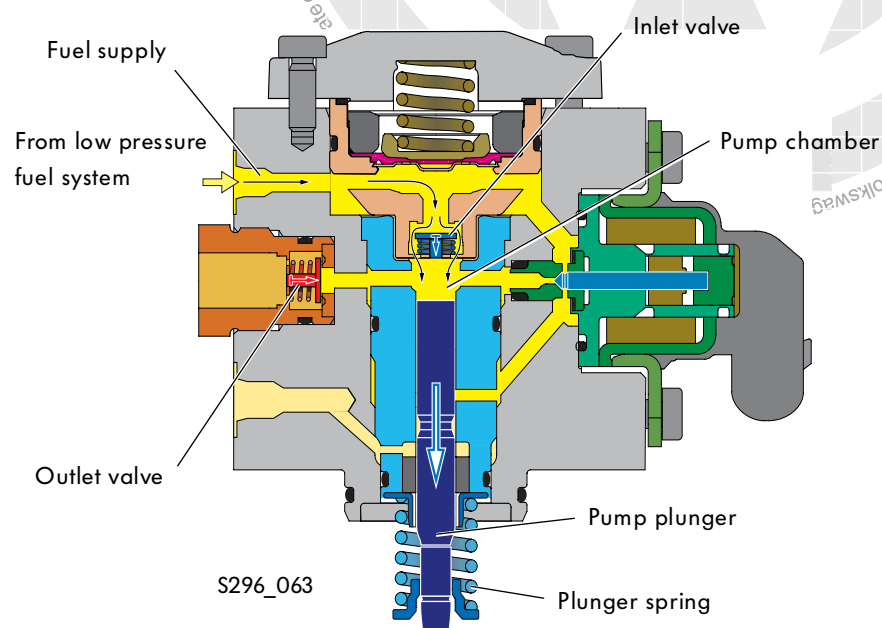

S296\_063

### Delivery stroke function:

Once the pump plunger begins to rise, pressure increases in the pump chamber and the inlet valve closes. If pressure in the pump chamber is greater than pressure in the fuel rail, the outlet valve will open and fuel will be pumped to the fuel rail.

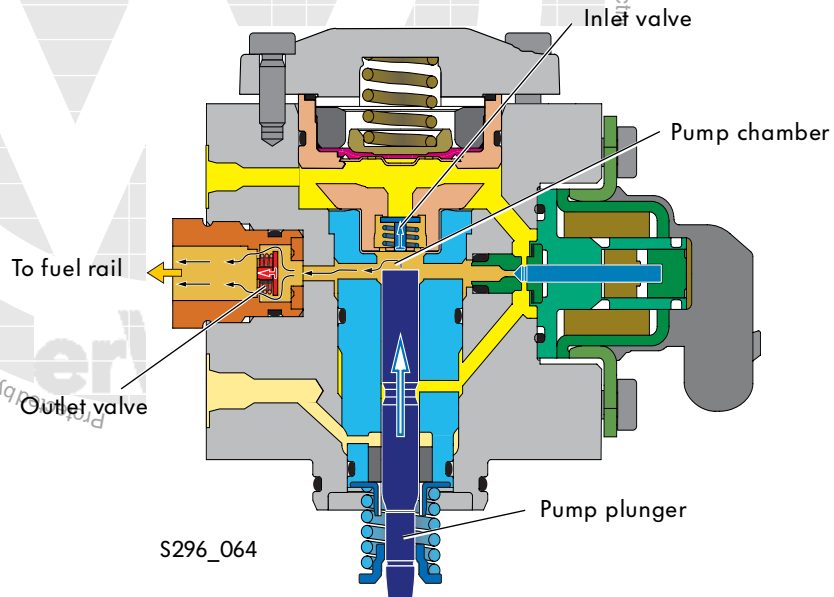

### Fuel pressure regulation:

Once the required fuel pressure has built up, the fuel pressure control valve is charged and the valve needle is actuated electro-magnetically. This frees the way for fuel supply, high fuel pressure in the pump chamber is reduced and the outlet valve closes.

The pressure damper serves as a means of rapidly breaking down peaks in pressure when the control valve is opened and it prevents surges in pressure in the low pressure fuel system.

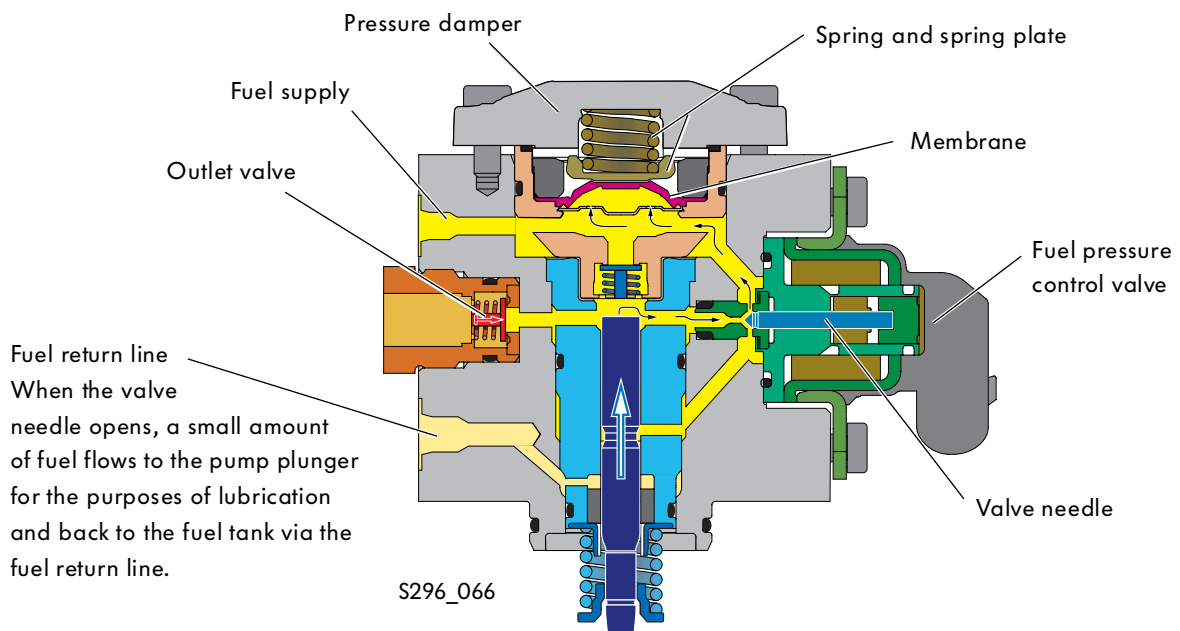

# Engine management

## Functional diagram (1.4 ltr./63 kW FSI engine)

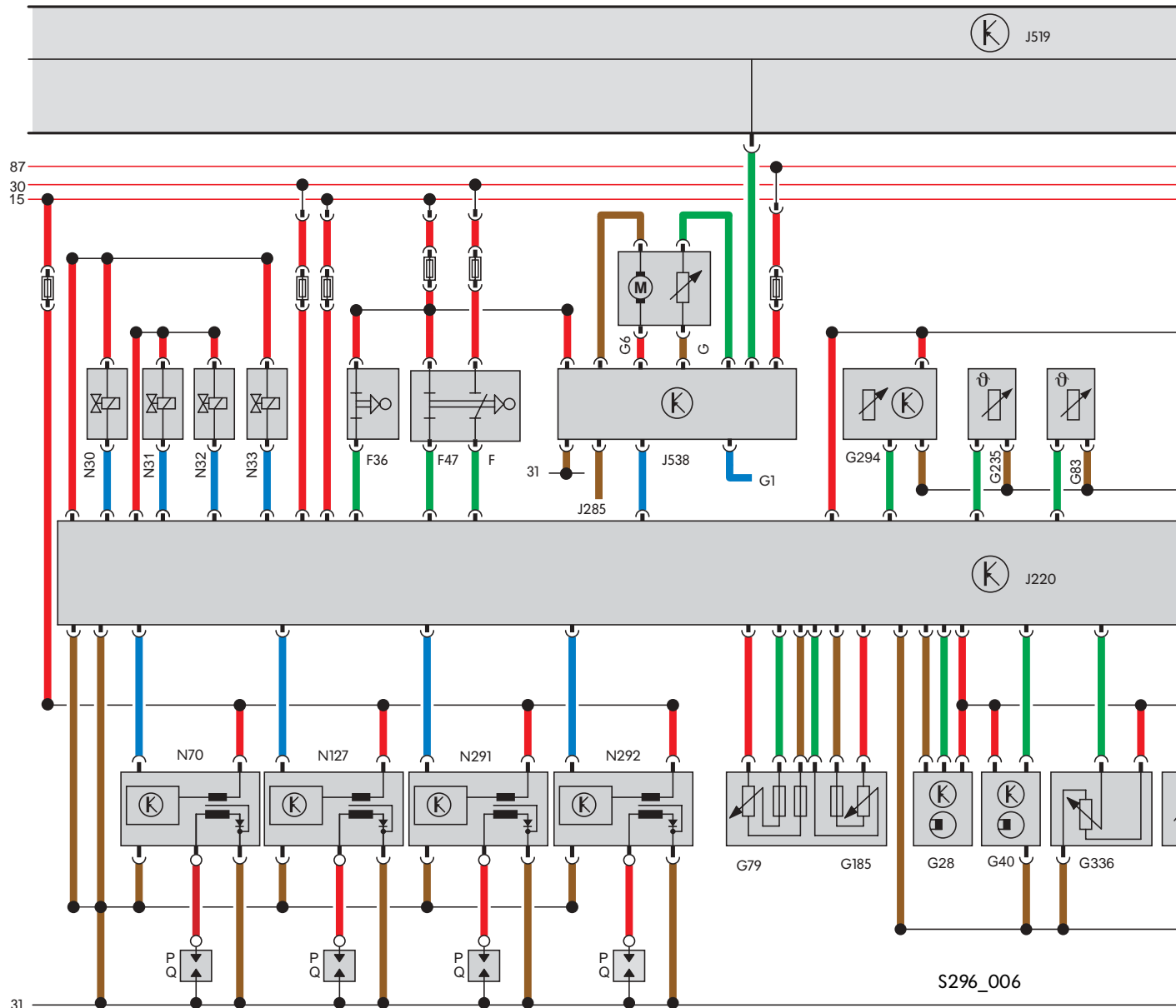

- F** Brake light switch
- F36** Clutch pedal switch
- F47** Brake pedal switch for CCS
- G** Fuel gauge sender
- G1** Fuel gauge
- G6** Fuel pump
- G28** Engine speed sender
- G39** Lambda probe
- G40** Hall sender
- G42** Air intake temperature sender
- G61** Knock sensor 1
- G62** Coolant temperature sender
- G71** Intake manifold pressure sender
- G79** Accelerator pedal position sender
- G83** Coolant temperature sender - radiator outlet

- G185** Accelerator position sender 2
- G186** Throttle valve drive
- G187** Throttle valve drive angle sender 1
- G188** Throttle valve drive angle sender 2
- G212** Potentiometer for exhaust gas recirculation
- G235** Exhaust gas temperature sender 1
- G336** Intake manifold flap potentiometer
- G247** Fuel pressure sender, high pressure
- G294** Brake servo pressure sensor
- G295** NOx sender
- G299** Air intake temperature sender 2
- G410** Fuel pressure sender, vacuum pressure
- J220** Motronic control unit
- J285** Control unit with display unit in dash panel insert
- J338** Throttle valve control unit

S296\_006

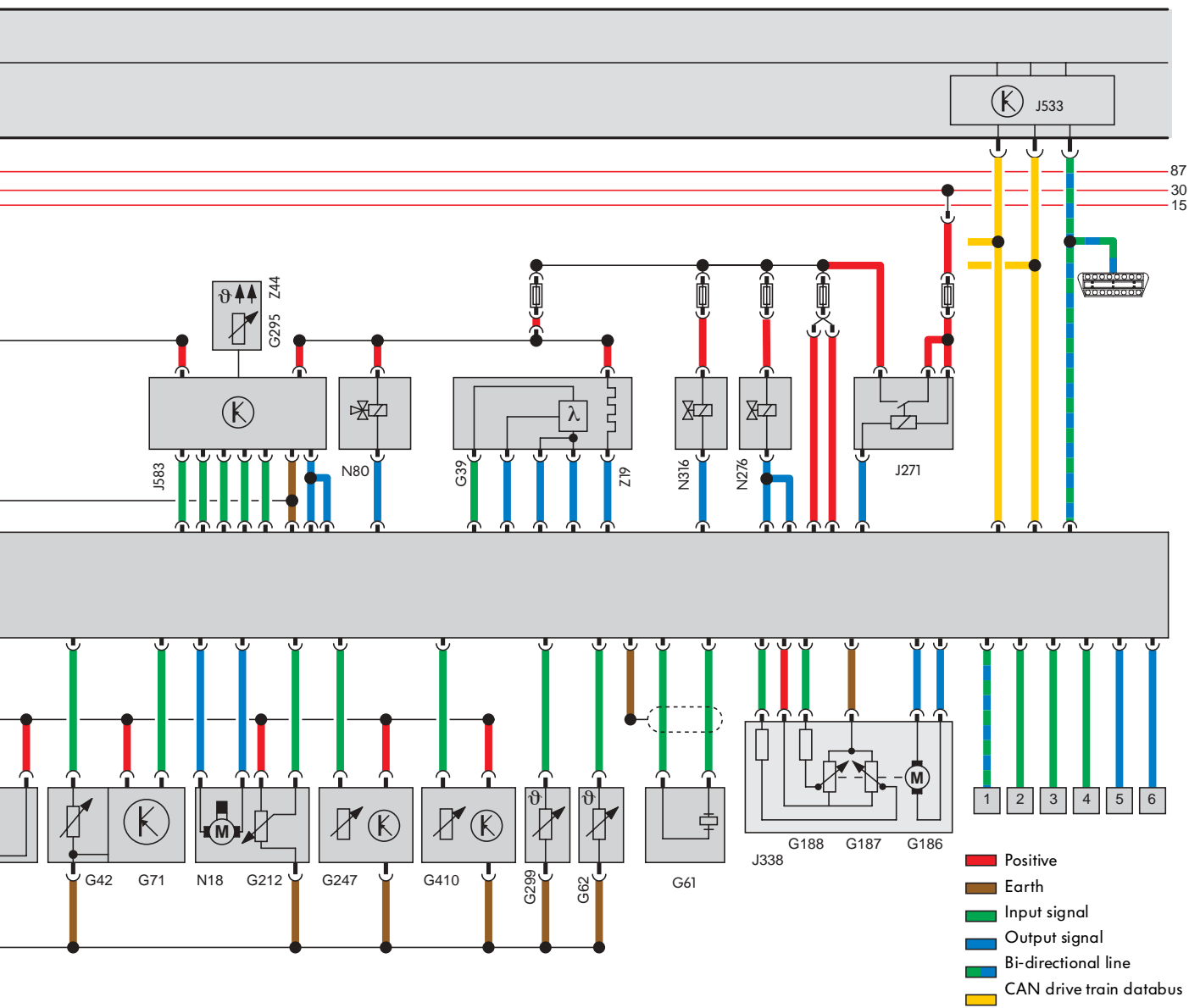

- J271** Motronic current supply relay
- J519** Onboard electrical supply control unit
- J533** Diagnosis interface for databus
- J538** Fuel pump control unit
- J583** NOx sensor control unit
- N18** Exhaust gas recirculation valve
- N30** Injectors 1 - 4
- N33** Ignition coil 1 with final output stages
- N70** Ignition coil 2 with final output stages
- N80** Solenoid valve 1 for activated charcoal filter system
- N127** Ignition coil 3 with final output stages
- N276** Fuel pressure control valve
- N291** Ignition coil 4 with final output stages
- N292** Intake manifold flap air flow control valve
- N316** Intake manifold flap air flow control valve

- P** Spark plug connector
- Q** Spark plugs
- Z19** Lambda probe heating
- Z44** NOx sender heater
- 1** K/W lead
- 2** Heater actuation
- 3** CCS switch
- 4** Alternator terminal DFM
- 5** Radiator control 1
- 6** Radiator control 2

# Service

## Self-diagnosis

### Diagnosis

On vehicle diagnosis, testing and information system VAS 5051 or vehicle diagnosis and service information system VAS 5052, the following modes of operation are available to you:

- Guided fault finding (VAS 5051 only)
- Vehicle self-diagnosis



S296\_042

"Guided fault finding" checks, specific to the vehicle, all installed control units for fault entries and automatically creates an individual test chart.

This guides you to the cause of the fault with the help of ELSA information, such as current flow diagrams or workshop manuals.

As an alternative, you also have the opportunity of creating your own test chart.

Via the function and component selection, the tests chosen by you will be included in the test chart and can be run through the diagnosis in any order.

"Vehicle self-diagnosis" can still be used in the normal way, but more detailed information via ELSA is not available.









S296\_043



Further information regarding "Guided fault finding" can be found in the VAS 5051 instruction manual.

## Special tools

Designation	Tool	Application
T 10133/1 Puller	 S296_044	Together with the slide hammer, the puller serves as a means of removing the injectors.
T 10133/3 Slide hammer	 S296_046	
T 10133/4 Nylon cylinder brush	 S296_048	For cleaning cylinder head drilling.
T 10133/5 Taper tool	 S296_045	For fitting new seals on injectors.
T 10133/6 Assembly sleeve	 S296_047	The assembly sleeve is used to fit the seal over the taper tool onto the injector.
T 10133/7 Calibration sleeve	 S296_053	For adapting the seal to the injector.
T 10133/8 Calibration sleeve	 S296_054	For adapting the seal to the injector.



# Test yourself

---

1. Which components are integrated in the engine cover?

- A. Hot film air mass meter G70
- B. Intake air temperature sender 2 G299
- C. Ambient air pressure sender in engine control unit J220
- D. Intake manifold pressure sender G71

2. Name the advantages of a dual circuit cooling system?

---

---

---

3. How many thermostats are installed in the coolant distribution housing and what are their function?

- A. One. Once the operating temperature has been reached, coolant flows through the radiator.
- B. Two. For separated flow of coolant, two thermostats are required, one for the cylinder block and one for the cylinder head.
- C. Three. In addition to the thermostats for the cylinder block and cylinder head, another thermostat is required for cooling of the electric exhaust gas recirculation valve.

4. What are the advantages of the regulated Duocentric oil pump?

- A. The output of the oil pump is reduced by up to 30 %.
- B. Wear in the oil is reduced as less oil is circulated.
- C. Build up of oil foam in the oil pump is minimised as oil pressure remains constant across the entire engine speed range.

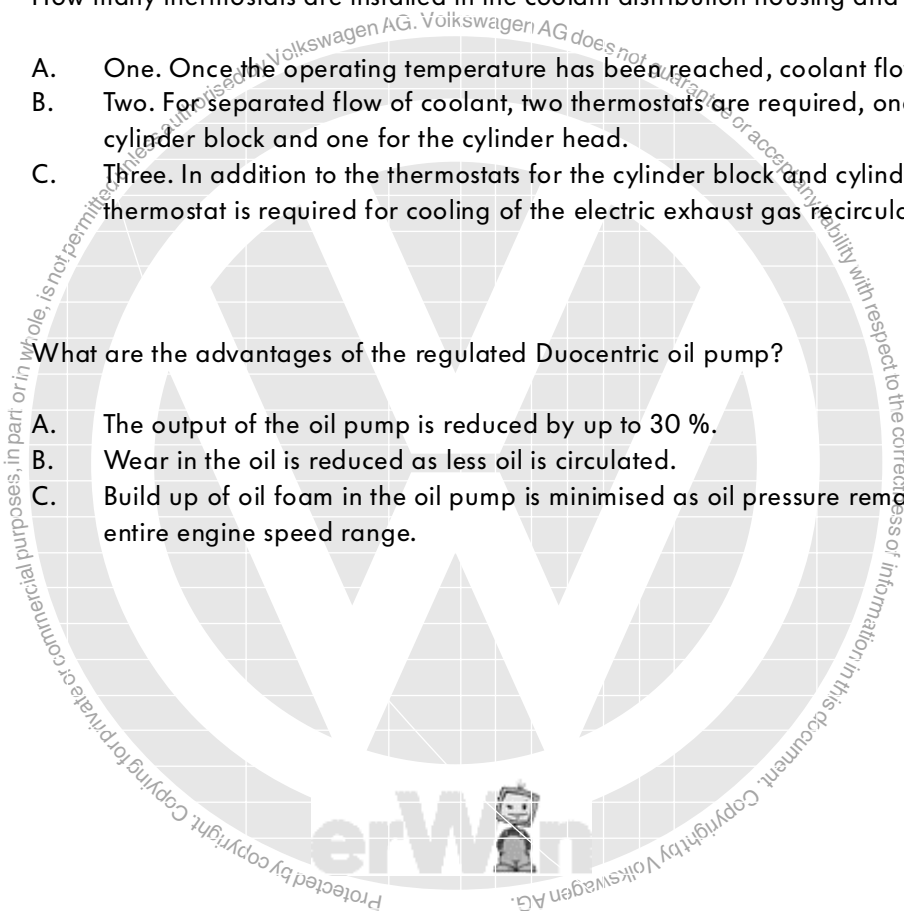

5. Which additional operating mode is there when the 1.6 ltr./85 kW FSI engine is compared with the 1.4 ltr./63 kW FSI engine?

- A. Stratified injection
- B. Homogeneous-lean
- C. Homogeneous
- D. Double injection, catalyst warm-up
- E. Double injection, full throttle

6. Which component is not part of the high fuel pressure system?

- A. High pressure fuel pump
- B. Fuel pressure control valve N276
- C. High pressure fuel line
- D. Fuel pump control unit J538
- E. Fuel rail
- F. Pressure limiter valve
- G. Fuel pressure sender, high pressure G247
- H. High pressure injectors N30-N33

7. Which components belong to the low fuel pressure system?

- A. Fuel pump control unit J538
- B. Fuel tank
- C. Pressure limiter valve
- D. Electric fuel pump G6
- E. Fuel filter
- F. Fuel pressure sender, low pressure G410

8. Which statement is true?

- A. The fuel pressure control valve N276 is screwed into the plastic fuel rail and regulates fuel pressure in the high fuel pressure system.
- B. The fuel pressure control valve N276 is screwed into the plastic fuel rail and regulates fuel pressure in the low fuel pressure system.
- C. The fuel pressure control valve N276 is screwed into the single cylinder high pressure fuel pump and regulates fuel pressure in the high pressure fuel system.

The cylinder block is warmed up faster. There is less friction in the crankshaft drive. Cooling in the combustion chambers is better.

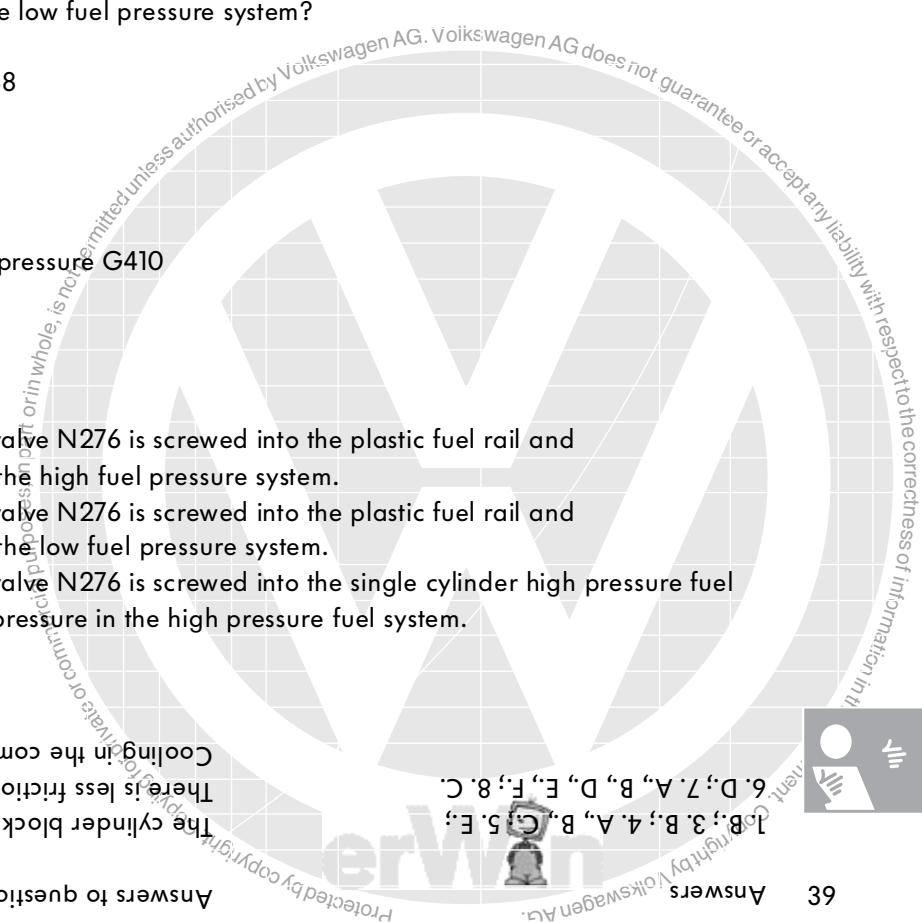



For internal use only © VOLKSWAGEN AG, Wolfsburg

All rights and the right to make technical alterations reserved

000.2811.16.20 Technical status 02/03

♻️ This paper was manufactured from pulp that was bleached without the use of chlorine.