

Service.



Self-Study Programme 270

The Phaeton



The Phaeton — Volkswagen's flagship — is based on developments in the international market for luxury goods: a product's quality alone is no longer sufficient to guarantee success in highly-developed markets. The prestige and value of the brand are decisive in influencing purchase decision-making.

Customers' brand awareness is becoming increasingly manifest, thereby necessitating Volkswagen's entry into the higher-class segment.

The launch of the Phaeton witnesses the development of a product which meets customers' technical requirements as well as satisfying the value and prestige demands made on the Volkswagen brand.



270_241



There are separate self-study programmes on the following topics:

- W-engines (SSP248/250),
- Air-conditioning/Heating (SSP271),
- On-board network (SSP272),
- Convenience and safety electronics (SSP273),
- Infotainment (SSP274),
- Air suspension (SSP275),
- Automatic distance control ADC (SSP276),
- Chassis (SSP277).

NEW

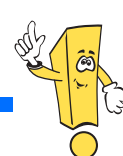

Caution Note

**The self-study programme illustrates the structure and operation of new developments!
Contents will not be updated.**

Please refer to the appropriate service material for current test, setting and repair instructions.

At a Glance



In a nutshell	4
Bodywork	12
Passenger protection	26
Engines	32
Gearbox	38
Chassis	50
Convenience electronics	52
Electrics	56
Heating/air-conditioning system	66
Infotainment	70
Service	74



In a nutshell



The Phaeton name

The **Phaeton** or **Phaethon** name is originally derived from Greek mythology. **Phaeton** (the 'incandescent') was the son of the sun god Helios, who was the owner of the sun chariot.

Derived from this, **Phaetons** also refer to the four-wheeled walking coaches which have been popular since the 18th century. This refers to open owner-driver carriages, featuring a trestle seat for 2 persons with or without a canopy top. Behind the trestle seat there is a seat for one or two passengers facing forwards.

Even nowadays, these **Phaetons** are driven at special tournaments - original specimens having become extremely coveted collector items.

At the onset of the 20th century, the term **Phaeton** stood for touring carriages with a fabric canopy and without side windows.



270_150

The name's phonetics*

Phaeton - How's it pronounced?

Phaeton is pronounced as follows:

Fay - ton.

The ending is spoken with an unvoiced 'N', comparable with the pronunciation of the word **Futon**, **Flacon** or **Anton**.

*Phonology

Phaeton's place in automotive history

Since 1910, August Horch endowed some of his models with the "**Phaeton**" suffix. The Horch 18/90 bhp **Phaeton** 1931, the Horch 12/28 bhp **Phaeton** 1911 as well as the Horch 853A Parade **Phaeton** with only three specimens dating from 1937, the last remaining model of which is being traded at US\$ 334,000, are just a few examples.

The fact that Volkswagen has chosen the name **Phaeton** for the group's flagship is an indication of the continuation of a tradition of making superior quality-control requirements in the production phase, thus providing the ultimate in exclusivity for each future owner of a **Phaeton**.



270_169

Horch 18/90 bhp 450 **Phaeton**, 1931-32



270_170

Horch 12/28 bhp **Phaeton**, 1910-11



270_168

Horch 853A Parade **Phaeton**, 1937





The concept

The transparent factory represents a further significant milestone for Volkswagen's customer-oriented manufacturing and delivery. Not only has the exclusive Phaeton led to the building of an impressive production line in Dresden, but it has also engendered the inception of a polished and precisely-functioning logistics concept. In addition to these outstanding technical production details, purchasers of this high-grade automobile can expect a perfectly-arranged vehicle transfer corresponding to an event of superlative pomp.

The Transparent



270_128

The production

Contrary to the popular opinion that automobile manufacture is irrevocably linked with dirt and oil, the vision of manufacturing evident in Dresden depicts production in an almost noble light. The core element of the manufacturing process features overlapping conveyor belts with fine wood parquet instead of metal lines. This high-grade optical characteristic in the production line is reminiscent of a manufacturing atmosphere otherwise witnessed only in elite luxury sports car forges.



Factory



270_130

The event*

An exclusive automobile cries out for the appropriate stage-management of its delivery. Customers are the centre of attention in the transparent factory's emotionally and technologically impressive discovery area. Potential Phaeton owners are treated to a birds-eye view of production via livecam during a Virtual Production Tour.

*happening, show

The logistics

An automated system steers the baskets containing the vehicles' individual components through the factory. The basket 'accompanies' the corresponding vehicle throughout the assembly stage. This avoids unnecessary journeys. The chassis, including the engine, gear-box and exhaust system, as well as the body are simultaneously mounted on different floors, being transported to a different level in a glass elevator, before being finally assembled into the complete vehicle. Once the manufacturing process has been completed, the Phaeton is once again placed on the overlapping conveyor belt before receiving its finishing touches and its final check.



In a nutshell



The Phaeton

This two-page spread affords an overview of technical innovations. Detailed descriptions of the individual topics can be found in this and other Phaeton self-study programmes.

Phaeton innovations



- Rear window heated by practically invisible tungsten threads
- Mudguards and spare tyre recess made of plastic
- Extremely narrow body jointing, PVC-free underbody protection
- Doors, engine bonnet and tailgate made of aluminium

- Fully-galvanised body
- Tail lights with 2-colour LED technology
- Antennae invisibly integrated in the rear window



- Superior paintwork, anti-scratch, exceptional brilliancy
- Air-conditioned 12- and 18-position seats, keyless access function, automatic distance control, multifunctional steering wheel



- Infotainment system with navigation, TV and radio/CD, CD changer in the glove compartment, 4-zone air-conditioning, solar roof



- Xenon headlights with automatic headlight range control

- Surrounding illumination via front, rear and forward lighting simplifies orientation when getting out of the car in the dark
- 4-corner air suspension with automatic control
- Electro-mechanical high-pressure nozzles for cleaning headlights
- Heated, heat-insulating and infrared-reflecting windscreen

- Side and rear windows made of twin-pane laminated safety glass

270_054

Technical data

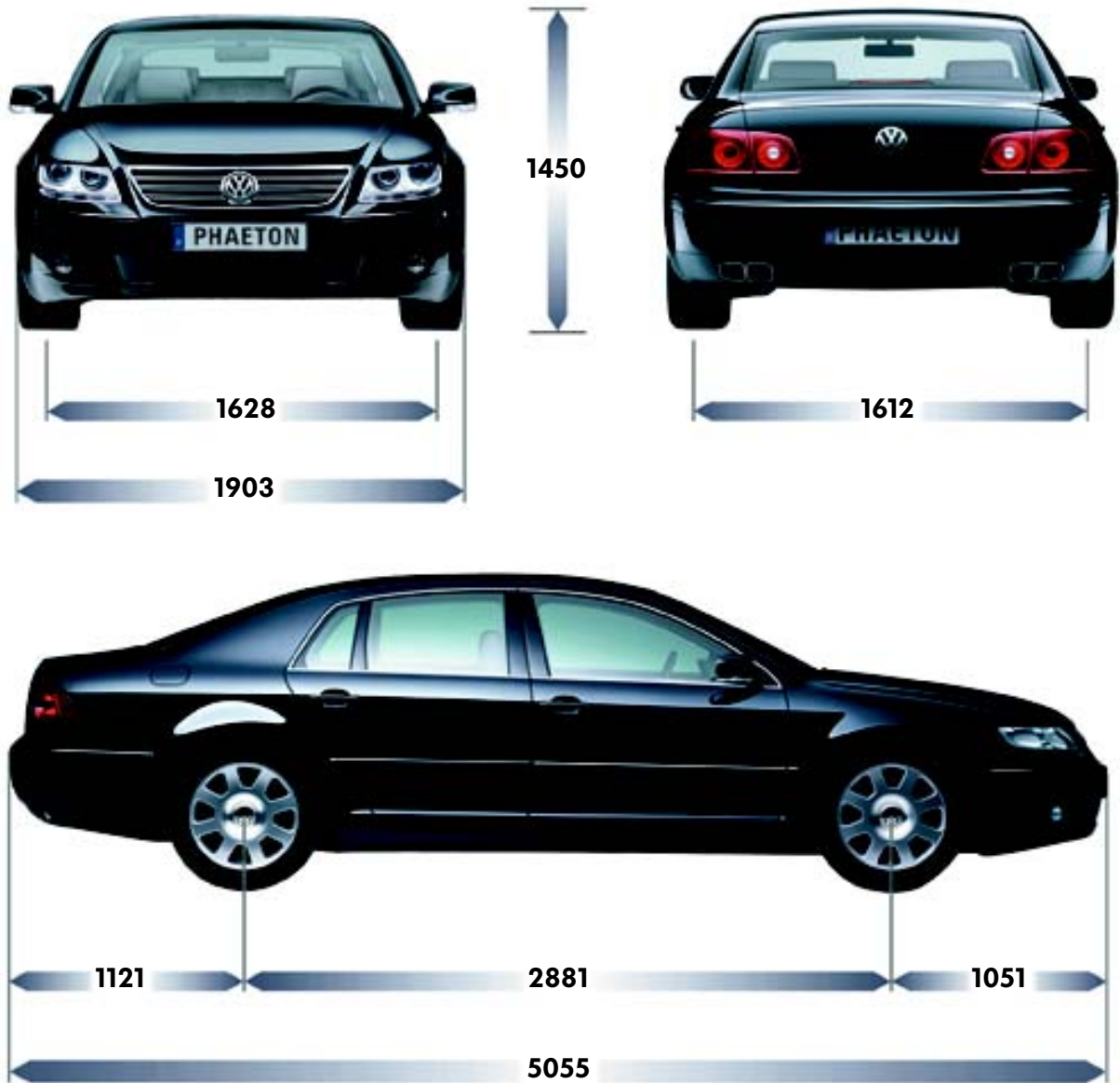

270_118

Dimensions and weights

Length	5,055 mm
Width	1,903 mm
Height	1,450 mm
Wheelbase	2,881 mm
Turning circle	12 m
Tank volume	90 l

Front track width	1,628 mm
Rear track width	1,612 mm
Total permitted weight	2,600 - 2,990 kg*
Empty weight	1,995 - 2,413 kg*
Luggage compartment space	500 l
Drag coefficient	0.32 c_w

*depending on the engine



270_047

The aerodynamics

The Phaeton has a low drag coefficient of 0.32 cw — a level which was achieved by applying various measures:

- The underbody has an extremely smooth design,
- The windscreen wipers are embedded,
- The body gap dimensions are very low,
- The front has an arrow-shaped design and
- The body is lowered at higher speeds.

Small features such as the retractable headlight cleaning nozzles, the antenna-free body and the smooth body transitions are also responsible for this low drag coefficient.

Bodywork

The raw bodywork of the Phaeton

The body structure

The Phaeton's bodywork is a complete innovation.

The core design focus involved a high level of crash safety and body rigidity. The gap dimensions of the flaps and doors prove to be very low due to the high body rigidity.

Doors and flaps are made of aluminium and the front mudguards are made of plastic in order to limit the weight while still observing the high safety and comfort requirements.

Furthermore, the bodywork consists of high-grade and super high-strength steels and is completely galvanised.

Static rigidity

The extremely high static rigidity is a prerequisite for:

- optimal chassis design due to almost complete lack of inherent movement within the bodywork and
- excellent door and flap functioning with the tightest of gap dimensions.

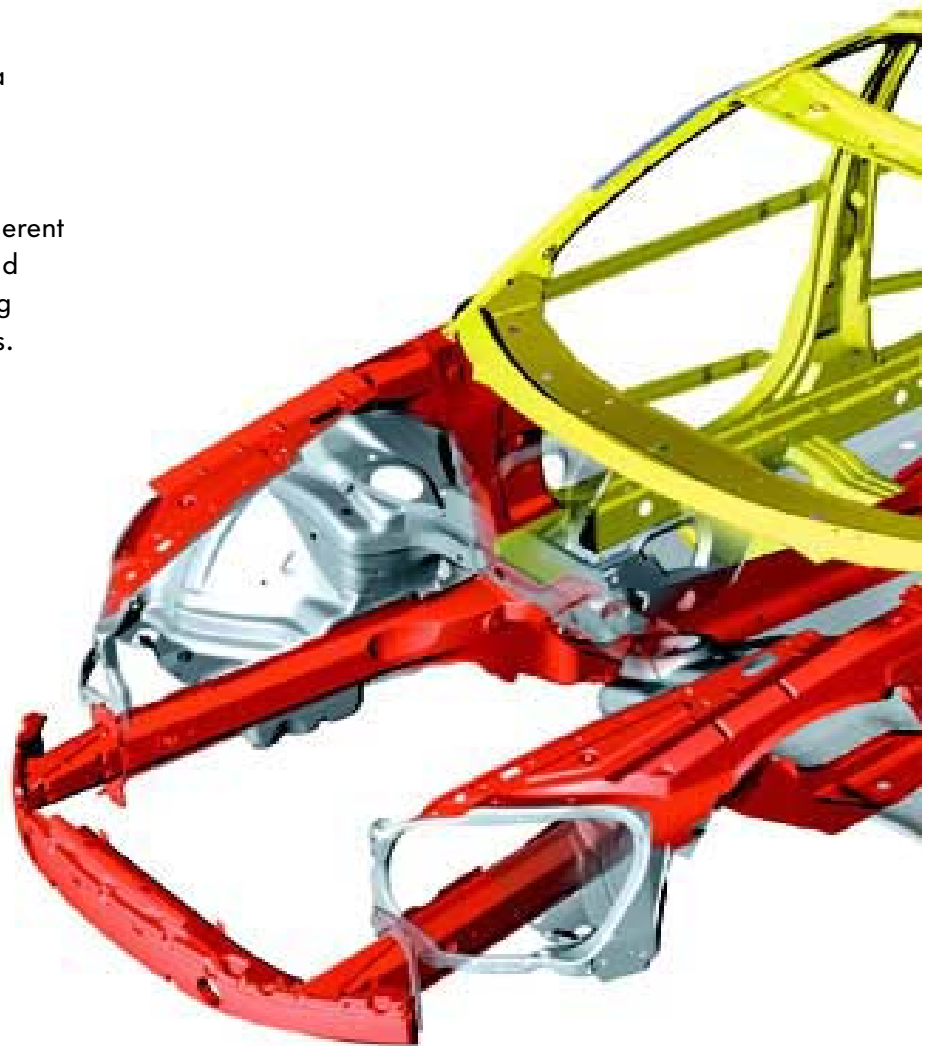

270_154

Safety features of the raw bodywork

- High energy absorption at the front and rear of the vehicle
- Stable passenger compartment
- High protection in event of side impact due to the:
 - bonding of the B-pillar made of super high-strength steel with the side member,
 - high-strength aluminium profiles in the doors
- Partner protection: Due to the relatively soft external bodywork areas, the crash performance is designed to afford maximum protection to other parties involved in an accident.
- Use of high-grade and super high-strength steel in important areas

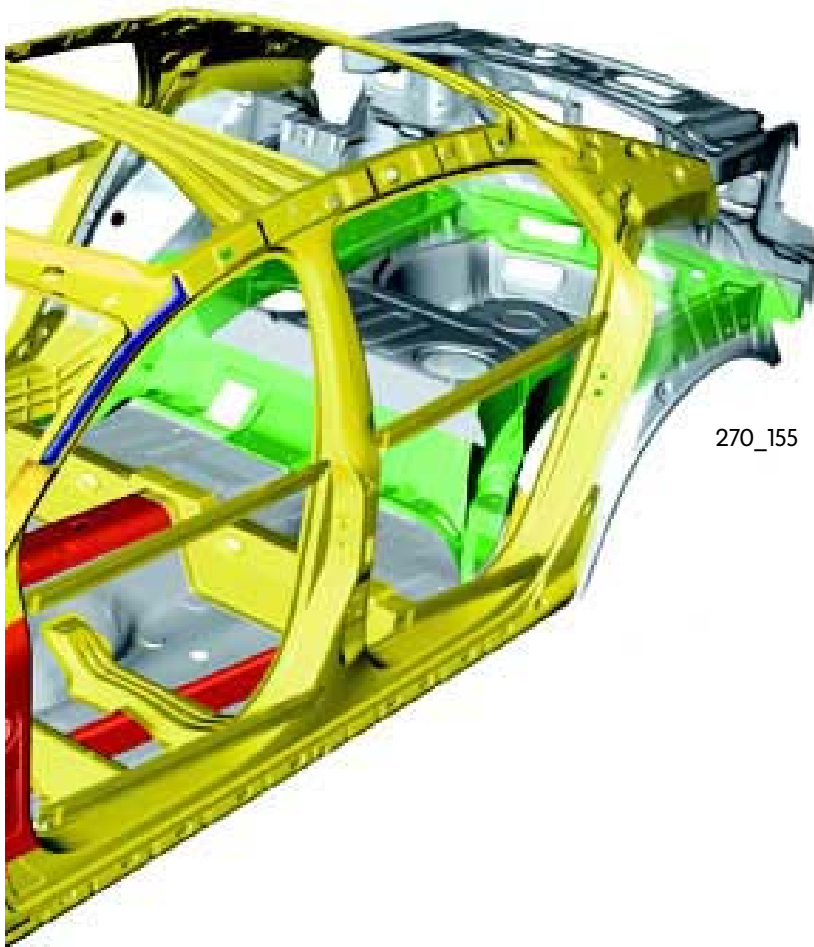

Dynamic rigidity

The high dynamic rigidity is a prerequisite for:

- advantageous vibration characteristics and thus for a high level of comfort and
- acoustic comfort (no noises caused by movement of the interior panelling).

Key:

- red = main frontal crash area
- yellow = passenger compartment
- green = main rear crash area
- dark blue = epoxy resin foam
- light blue = plastic reinforcement

Bodywork

Bodywork attachments

Aluminium parts

- Engine bonnet
- Reinforced doors
- Tailgate

Plastic parts

- Front mudguard
- Fuel cap
- Spare tyre recess
- Front and rear bumpers



not permitted unless authorised by Volkswagen AG. Volkswagen AG does not guarantee or accept any liability



Key:

- blue = aluminium parts
- brown = plastic

270_114

Glued-in-place plastic spare tyre recess

The following components are integrated in the spare tyre recess:

- Compressor for air suspension,
- Activated carbon filter and
- Spare wheel.

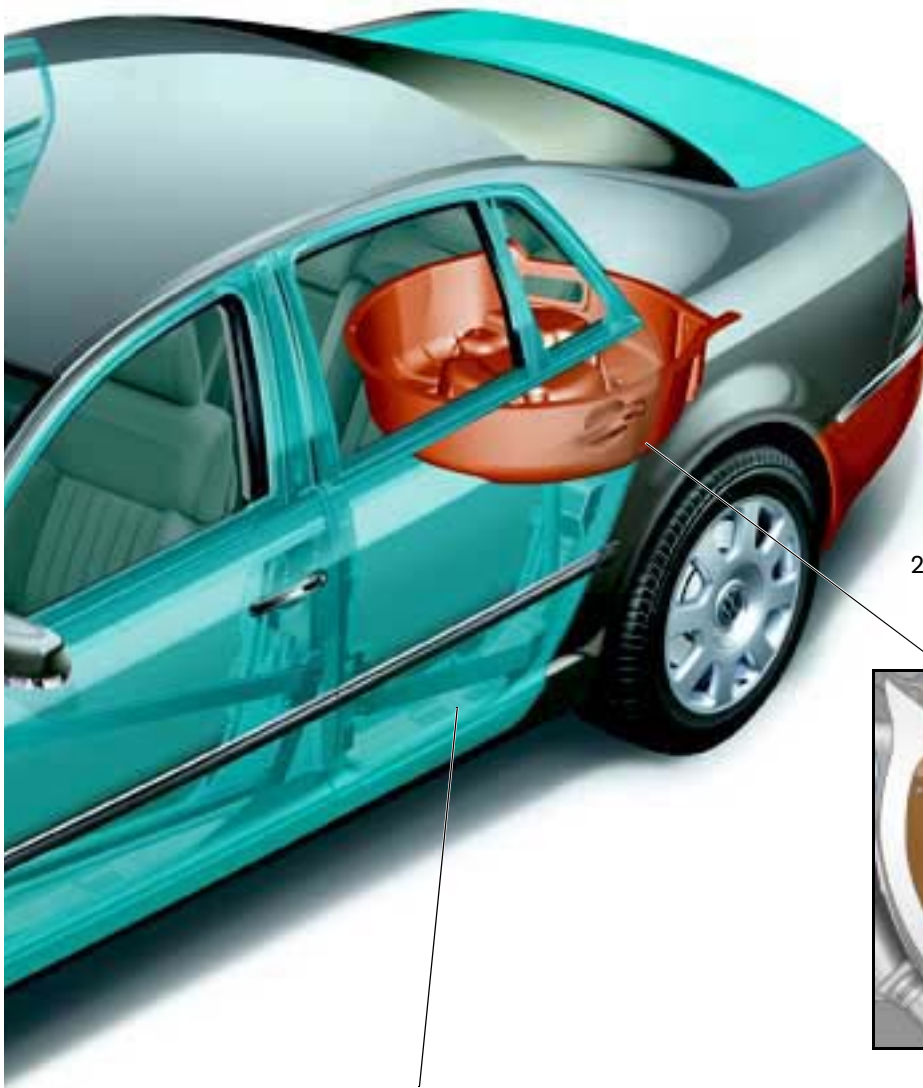

270_115



270_004

Doors with high-strength inner sections made of die casting, laser-welded

Detailed view of spare tyre cavity, from below



Bodywork

The silencers

Sound deadening was already a major issue when developing the body-in-white. The consistent deployment of absorption materials in the engine compartment, tunnel, luggage compartment and behind the panelling has led to the attainment of an above-average reduction in noise.



Diesel and petrol engine

The two-tone insulating foils demonstrate the different insulation methods in the diesel and petrol engine.

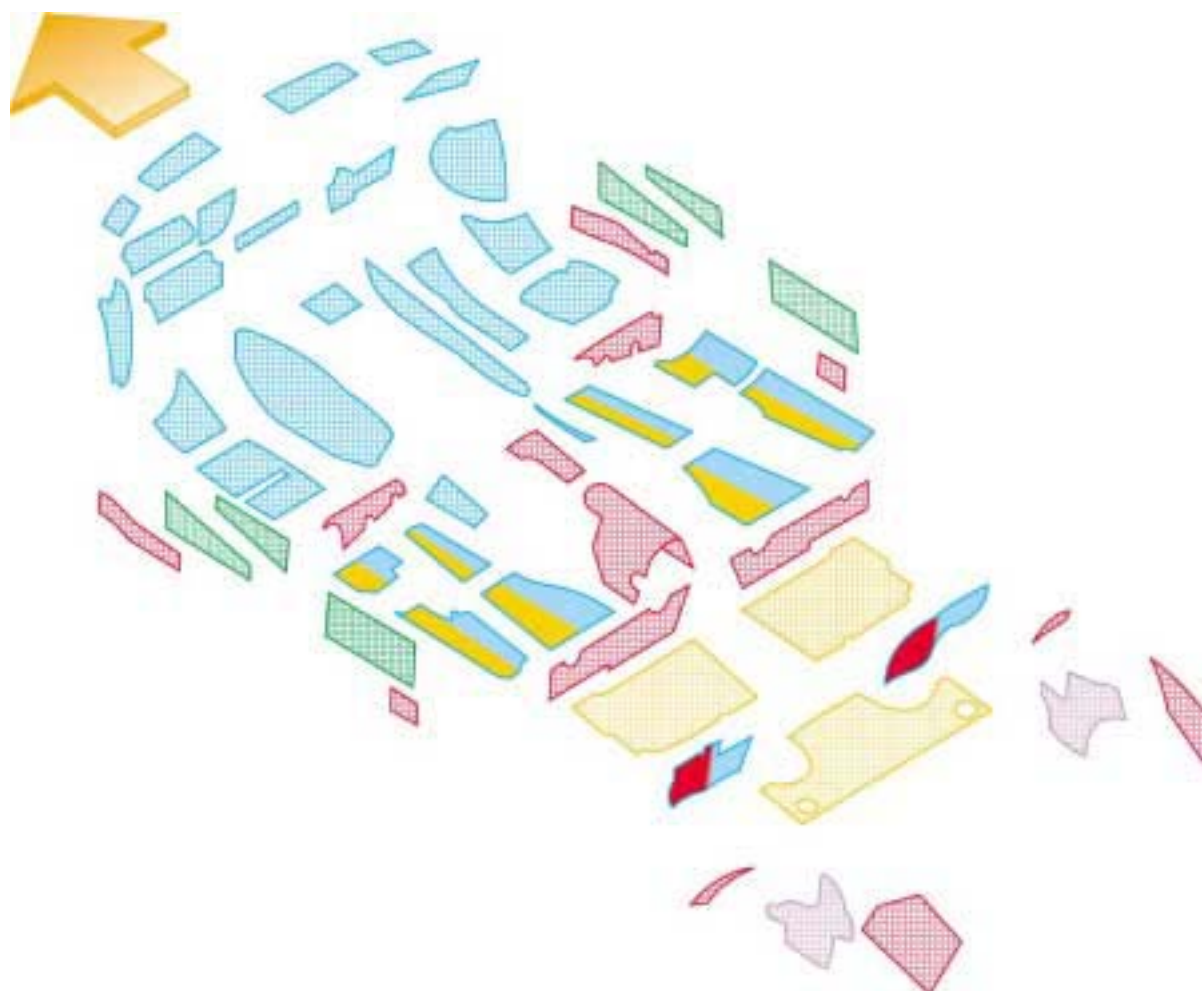

270_182

Key:

- blue = aluminium expansion foil, 4.5 mm sandwich
- green = bitumen plastic-foil, pressure-sensitive bonding, 2 mm
- red = bitumen plastic-foil, magnetised, thermoplastic bonding 2 mm
- orange = bitumen plastic-foil, thermoplastic bonding 2 mm
- pink = bitumen foil with aluminium foil, magnetised, 3 mm
- blue/red = blue - diesel, red - petrol engine
- blue/orange = blue - diesel, orange - petrol engine

High-insulation glazing & laminated glass

The high-insulation glazing made of laminated glass distinguishes itself with its improved reduction of thermal exposure, however, without influencing permeability to light.

The glazing reduces ultraviolet radiation and contributes to an improved noise insulation. This is facilitated by two foils incorporated into the glazing. The rear and side windows are also manufactured with thermally-tempered laminated glass with an infrared reflective coating. This improves safety as laminated glass panes cannot shatter due to their incorporated safety foils.

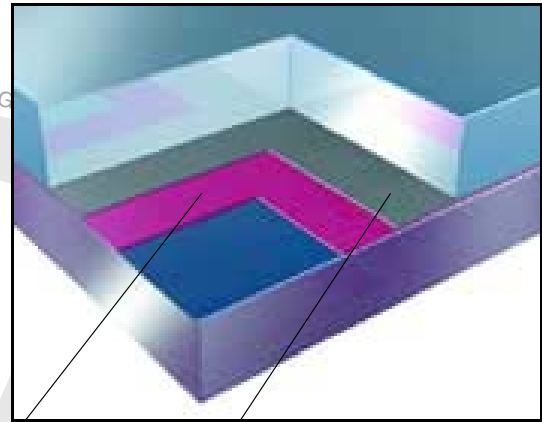

Ultraviolet protective foil

Infrared reflective coating
(heated windscreen)

270_040

Windscreen

- Two-layer, burglar-inhibiting, heat-insulating, laminated safety glass
- Electric windscreen heating (optional) with invisible filaments through an electrically conductive infrared reflective coating.
- The heated windscreen is switched on and off using the 'Defrost' button at the display and operating unit at the front

Heating duration depending on outside temperature:

5 to 0 °C	=	2 minutes
-20 °C	=	4 minutes
-40 °C	=	6 minutes

In order not to overload the on-board network, the heating is switched off after a specific time-frame, depending on the outside temperature.

Rear window with tungsten threads

The rear window is heated by practically invisible tungsten threads which are embedded between the inner and outer pane. Furthermore, all antennae are integrated in the upper third of the rear window. The external streamlined quality is therefore not impeded by bothersome antennae.

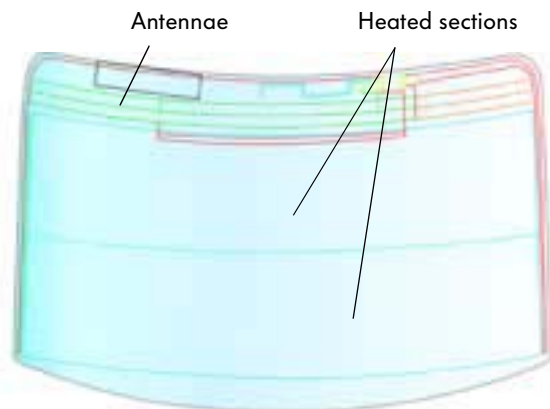

270_178



Bodywork

The tailgate

Power-assisted closing of the tailgate

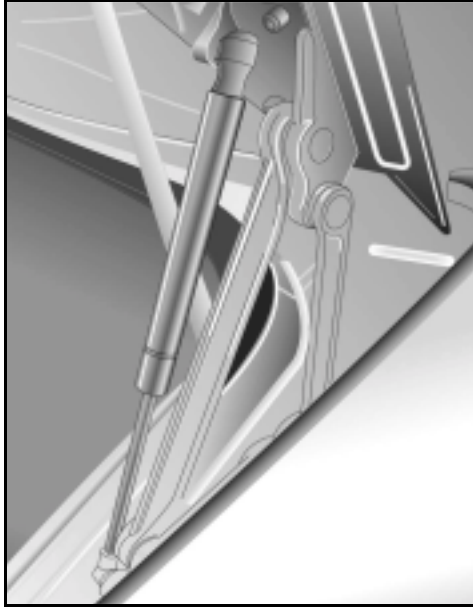

270_001

The Phaeton is also available with a system allowing the driver to automatically open and close the tailgate.

This power-assisted closure is not only a comfort feature but is also an enhancement of the entire locking mechanism.

Retractable rear lock with closing aid

The lock is retracted when opening the tailgate, thereby eliminating the risk of injury. The retraction of the lock also prevents the possible soiling of clothing by the oil or grease present in the lock.

When closing the tailgate, the lock re-emerges from the tailgate into locking position during the final third of the closing procedure. Then it pulls the tailgate the final centimetres into the lock and locks it (closing aid).

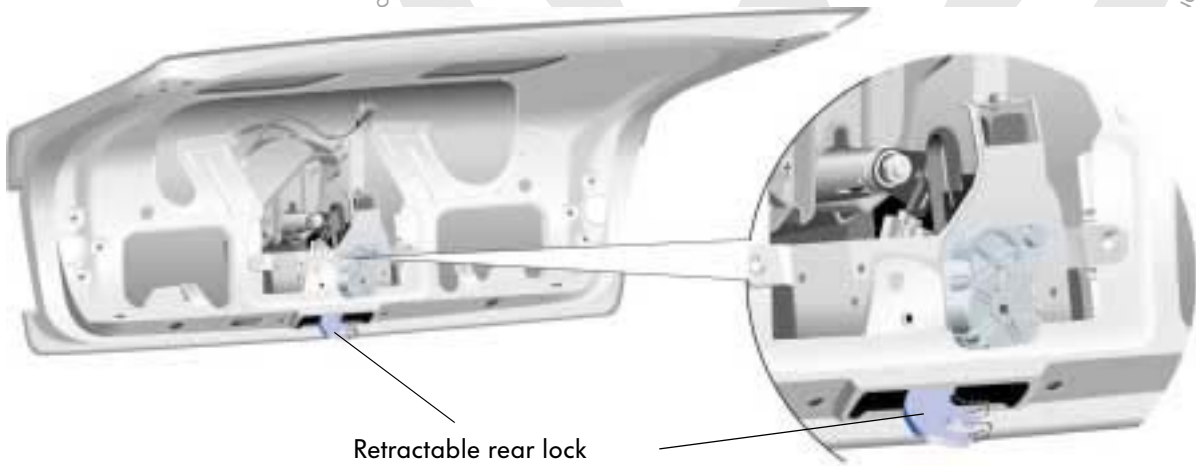

270_123

Function of the power-assisted closing

The power-assisted closing is based on an electro-hydraulic system. Oil is pumped into the hydraulic line system by an electric pump. The feeding of oil to the piston or piston-rod end of the hydraulic cylinder facilitates the opening or closing of the flap via a driving shaft at the door hinge. The pump is incorporated at the right of the tail section.

Opening

To open the tailgate, operate either the switch in the door panelling, the microswitch in the VW emblem on the tailgate or the radio-wave remote control.

Closing

The switch in the tailgate serves the purpose of closing the tailgate.

Safety equipment

The power-assisted closing has an anti-trap feature. If the electric motor in the hydraulic component perceives resistance which exceeds a defined level, power-assisted closure is not merely stopped but reversed* a little in order to release the jammed object. The same procedure is adopted when opening. If, for example, it hits a low garage roof, the motor stops for a moment. However, the tailgate then remains in this position without reversing. Renewed actuation is then required.

*moves back

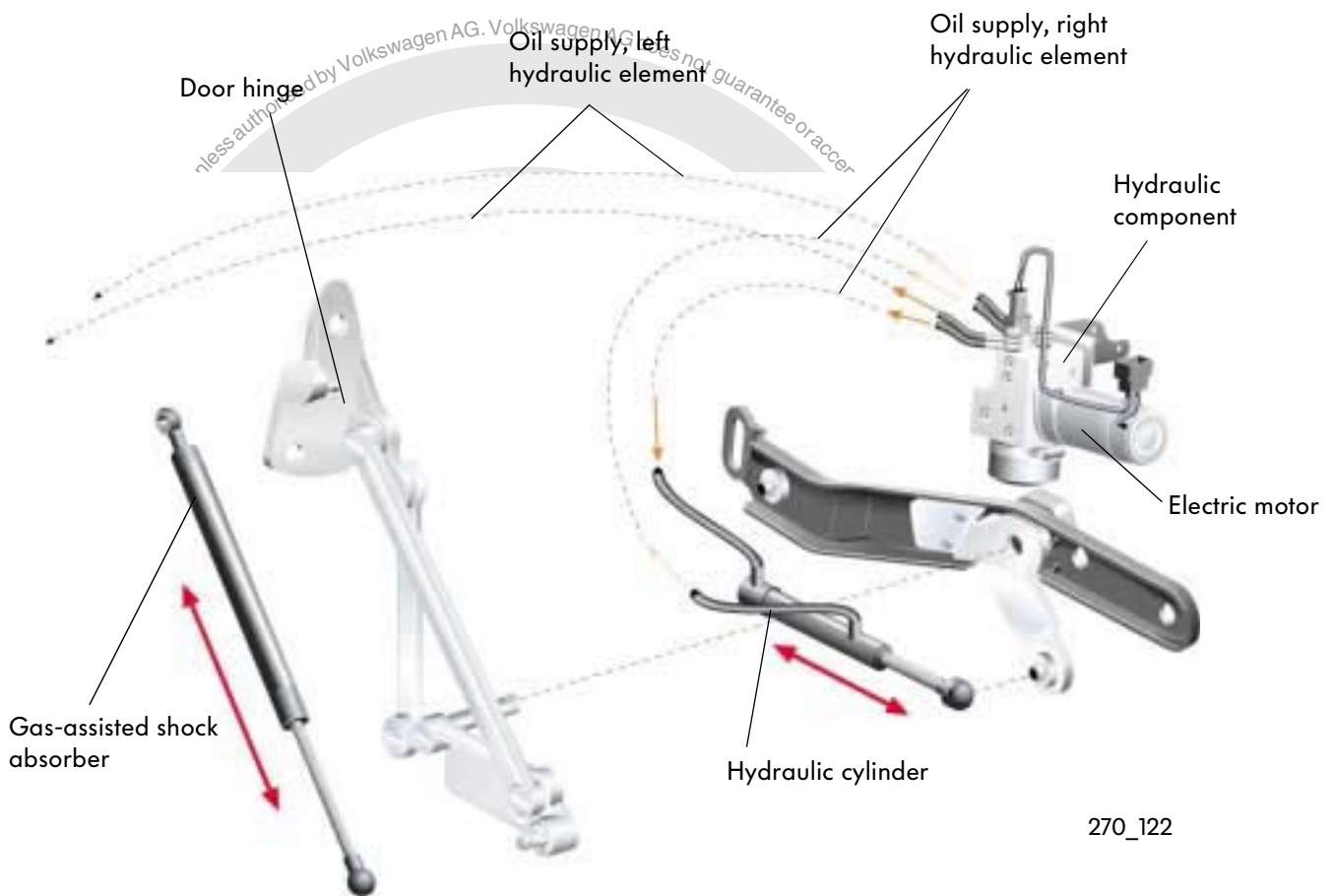

Bodywork

The sliding roof

The Phaeton is available with a solar sliding roof with a fixed inside roof lining and a sliding roof / lifting roof with a separate electrically-sliding inside roof lining.



Solar sliding roof

The solar roof's 28 monokristallin solar cells supply an electrical output of 37 watts. This energy is used to operate the interior ventilator which is capable of reducing the temperature by up to 20 °C, when the vehicle is parked, by feeding fresh air into the vehicle's interior.



270_124

If the interior ventilation has been activated via the Infotainment system, the interior ventilator starts operating when there is sufficient sunlight.

This cools down the interior at high temperatures. The circulation of air prevents the windows from misting in winter.



270_125

Sliding roof / lifting roof with solar shading and an electrical wind deflector

A separate electric motor moves the inside roof lining at the same time as the glass roof is opened or closed. This can also be adjusted regardless of the glass roof's position. All closing procedures are electronically monitored and have an anti-trap feature.

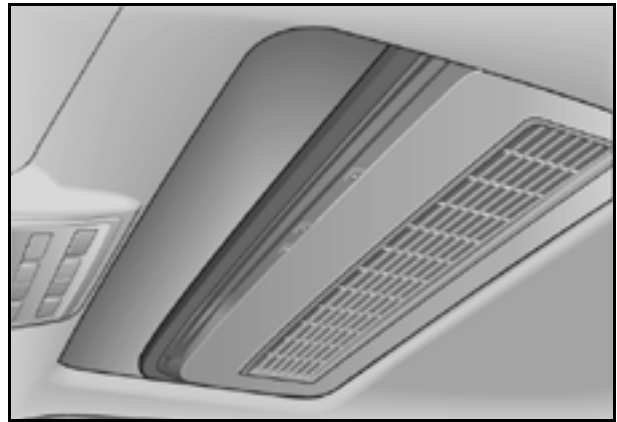

270_166

Depending on the driving speed and the roof opening, the wind deflector is controlled electro-mechanically in order to prevent wind noise and draughts.

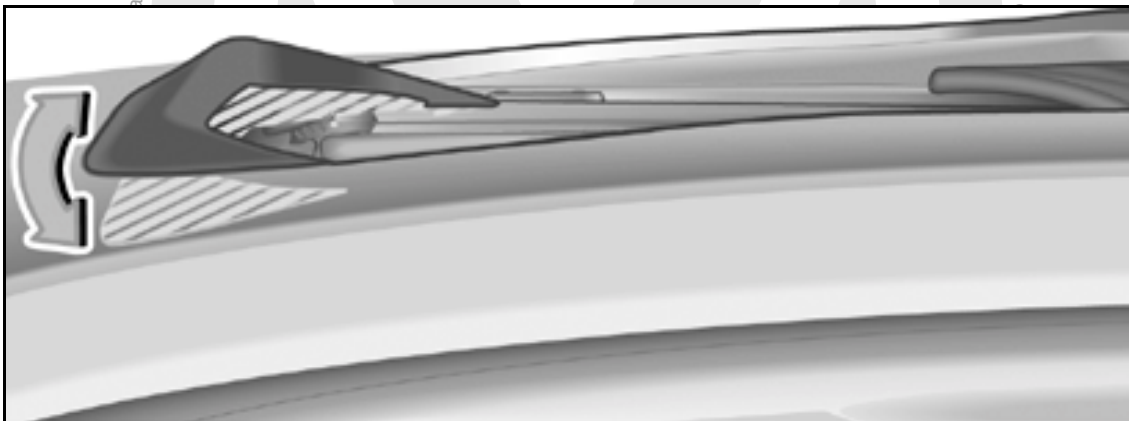

270_167



Seats

The front seats

The Phaeton is also available with air-conditioned seats. Air-conditioning is provided through the interaction between the seat heating and ventilators.

The ventilators, which are integrated in the seat frames, feed the air heated by the seat heating to the occupants through fine perforations in the seat leather. The massage function is imple-

mented by a slow adjustment of the lumbar support. The belt mechanism integrated in the seat endows the Phaeton with an even greater level of comfort. Furthermore, the optional second automatic belt in the 18-position seat gives increased belt comfort and improved safety. The Phaeton also has an active headrest system (AKS).

The 12-position seat

Adjustment function

As standard, the Phaeton comes with 12-position seats. The following functions are electrically adjustable: longitudinal direction, seat height and inclination, as well as the backrest inclination. Furthermore, the movement direction of the lumbar support is adjustable both backwards/forwards and up/down.

Memory functions

The memory package for the 12-position seats includes a range of saveable functions. In addition to the seat settings, the memory function can also save the positions of the steering column, the mirror and the seat belts.

Easy-entry function

The easy-entry function facilitates the convenient getting in and out of the vehicle by automatically moving the steering column into its uppermost and furthest-forward position.

Air-conditioning / massage function

Air-conditioning in the 12-position seats is provided by ventilators - which are integrated in the seats - and which feed temperate air through the fine perforations in the leather. The massage function is implemented through the mechanical



270_147



4-position lumbar support.

The lumbar support is moved automatically up and down, thus facilitating the relaxation of the spine and back muscles.



The 18-position seat

Adjustment function

As an optional extra, the Phaeton comes with high-quality 18-position seats. They also offer the option of adjusting the backrest head and the seat depth, as well as an electrical adjustment of the headrest.

The 18-position seat can be equipped with an automatic lap belt on request.

Memory functions

In addition to the functions featured in the 12-position seat, the memory package for the 18-position seat also offers the option of saving the positions of the headrest, the seat depth and the backrest head.



270_146

Air-conditioning / massage function

The range of air-conditioning functions in the 18-position seats is equivalent to that of the 12-position seats.

Seats

The rear seats

The Phaeton comes with three seating versions for rear-seat occupants: individual seats, back seat and the 'Premium' back seat

The individual seats

The Phaeton version with the 18-position seat also comes with the option of 10-position individual rear seats.

The individual seats can be adjusted electrically with regard to longitude and inclination. The headrests and 4-position lumbar support are also electrically adjustable. The individual seats are air-conditioned with temperate air which is fed through the perforations in the leather.

Moreover, the memory function in the version with individual seats also offers the option of saving several seat positions.

The control unit for the rear seats is incorporated into the centre console at the rear.

This is also the location of the control dial for the rear seat heating. Moreover, the passenger seat can be moved forward with a separate button.



270_050

The back seat

The back seat in the standard version can comfortably accommodate three people. Side air-bags and manual headrests (adjustable in height and inclination) are also provided.

The following features have been added to the comfort-orientated 'Premium' back seat system: electrical lumbar support in the outside seats including ventilation, massage and seat heating, as well as headrests whose height can be electrically adjusted.

The controls for the rear seats are attached laterally to the seat cushion.

The control dials for the back seat heating are located in the centre console at the rear.

Moreover, the passenger seat can be moved forward with a separate button.



270_143

Passenger protection

General passenger protection

The Phaeton has sophisticated active and passive safety equipment. Volkswagen has redefined safety standards in luxury class cars by deploying lighter but high-strength materials, improved deformation features, curved edges and shatter-proof plastics, all-round safety glazing, improved airbag sensory mechanism and optimised belt tensioning systems. Phaeton not only places an

emphasis on your own safety, but also on the safety of other vehicles involved in the event of a collision. The improved deformation behaviour of the Phaeton's bodywork decreases the damage incurred by other vehicles involved in an accident situation.



Airbag systems

The Phaeton is equipped with 4 different airbag systems. All airbags are triggered by the airbag control unit which registers the gravity of the accident via the early-crash sensors, thus preventing the unnecessary triggering of the airbags in the event of a minor accident. Details of the type and gravity of a collision are fed to the control unit by sensors which are located at the front headlight mounting.

Furthermore, all airbags are 'depowered' in order to prevent injury when the air sacks are being opened. 'Depowered' means that the airbag opening flaps and the folding of the airbags have been optimised to an extent which reduces the aggressive effect of the triggering of the airbags on the occupants.

Airbag deactivation

The front and side airbag for the front passenger can be deactivated with the ignition key. For this purpose, a lock is located in the centre console next to the selector for the automatic transmission. Here one can use the ignition key to select one of two positions (Airbag on/Airbag off).

On the other hand, the side airbags at the rear and the head airbag at the passenger side cannot be deactivated. However, they only receive a trigger signal from the airbag control unit when the lateral crash sensors register a corresponding impact.



270_192



270_193

The Phaeton is available with the following airbag systems:

- Driver and front passenger airbag (ca. 75l/120l),
- Side airbag at front and rear (ca. 12l),
- Head airbag (ca. 31l).

The driver and front passenger airbags are triggered by the airbag control unit. The control unit is fed information regarding the type and gravity

of a crash by an internal and two external longitudinal acceleration sensors. The side airbags are triggered by the airbag control unit which has one internal and four external traverse acceleration sensors at its disposal. The head airbags are triggered electrically in conjunction with the side airbags.



Rear side airbag



270_019

Front side airbag



270_026

Front passenger airbag

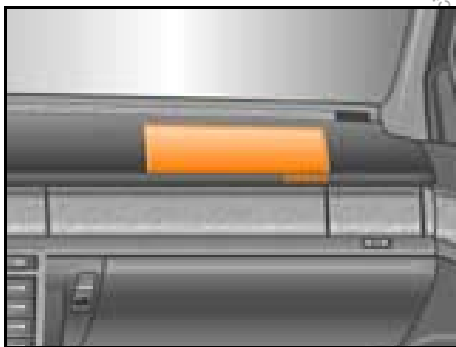

270_023

Driver airbag



270_025

Head airbag



270_024

Passenger protection

Belt system

All seats on the Phaeton possess three-point retracting seat belts with belt tension limiters. Furthermore, all outside seats are fitted with pyrotechnical seat belt tensioners which are triggered by the central control unit if the gravity of the accident is deemed sufficient.

The 18-position seat version is also available with an optional belt system which is fitted with an

additional automatic lap belt. This extra automatic belt is attached to the side of the seat. In conjunction with the automatic shoulder seatbelt, it facilitates the simultaneous tightening of the belt in the occupants' shoulder and lap area. In the event of a collision, this leads to an early and extremely effective coupling of the occupants and vehicle.



The comfort mechanism on the shoulder belt tensioner

A force greater than that used in conventional belt buckles is required in order for the automatic 'Rollgurt' to retract the compound insertion tongue into its starting position in the double retractor system on the 18-position seat. However, in order not to transmit this force to the vehicle occupants, a mechanism in the automatic shoulder seatbelt is used which can vary the force exerted on the belt.

If a seat allocation is recognised by means of a belt buckle check, the mechanism reduces the force in the automatic shoulder seatbelt when it is being used. This prevents the seatbelt from exerting too much pressure on the occupant's upper body. The full force is once again available when the seatbelt is released. The mechanism is incorporated into the automatic shoulder seatbelt.

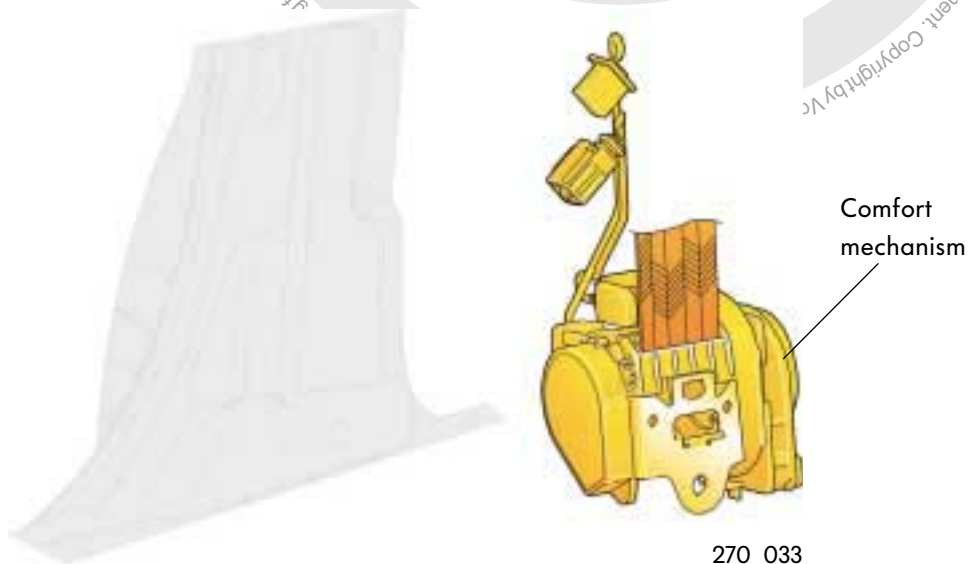

270_033

Front automatic shoulder seatbelt

In the standard version — the 12-position seat — an automatic shoulder seatbelt ensures optimal safety. This means that in the event of a collision, the seatbelt is tightened around the occupant's shoulders via the B-pillar. The shoulder belt has a spherical tensioner.

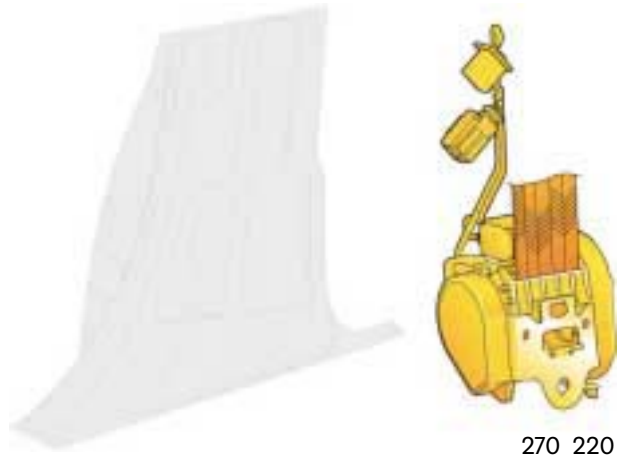

270_220



Automatic lap belt (optional)

The second automatic belt, which is attached to the side of the seat in the 18-position seat, affords increased safety as it simultaneously applies additional tension to the lap belt along with the automatic shoulder seatbelt. The automatic lap

belt also results in an increase in comfort as it is attached to the seat and is suitable for all seat positions. The ensuing increase in freedom of movement brought about by this gives one the sensation of not being belted in.



270_034

Commercial purposes, in part or in whole, are not permitted unless authorised by Volkswagen AG. Volkswagen AG does not guarantee or accept any liability with respect to the correctness of information in this document.

Passenger protection

Headrests

The front seats in the Phaeton are fitted with an active headrest system (AKS). Through a forward displacement of the headrests and the ensuing avoidance of relative accelerations between the shoulders and the head, this system lowers the risk of cervical spine injury in the event of a crash. The reversible system continues to be fully operable after the triggering of the AKS.



270_018

The mode of operation

The AKS is triggered only by a collision at the vehicle's rear. In the event of a frontal crash, its triggering is prevented by a safety block.

Impeding weight



270_102

If an accelerating force in the travelling direction is applied to the rear of the vehicle, the movement of the occupants is delayed by inertia. The body is therefore pushed into the seat. Due to this increased pressure on the backrest, a bent lever is turned in a way which causes the headrest to move upwards and forwards. This direction is determined by a rail guide in which the headrest is located.

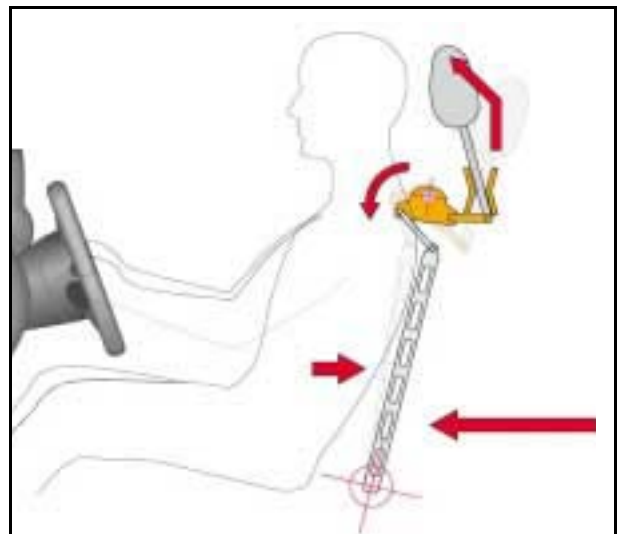

270_101



The full range of functions as well as the correct protective function of the active headrest system requires a body-specific seat setting for the respective occupants.

Installation/removal

(Only applies to 18-position seats with the 'lap-belt tensioner' option.)

The seatbelt has to be separated from the seat in order to remove the seats. This is done by detaching the insertion tongue's plastic covering and the subsequent removal of the metal pin which is secured with a sheet metal lock. As seen in the illustration, the insertion tongue's housing

is sawn open at the two joints with a little hack-saw. The topside can then be removed. Once the pin has been removed, the belt can be separated from the insertion tongue and the seat can be removed.

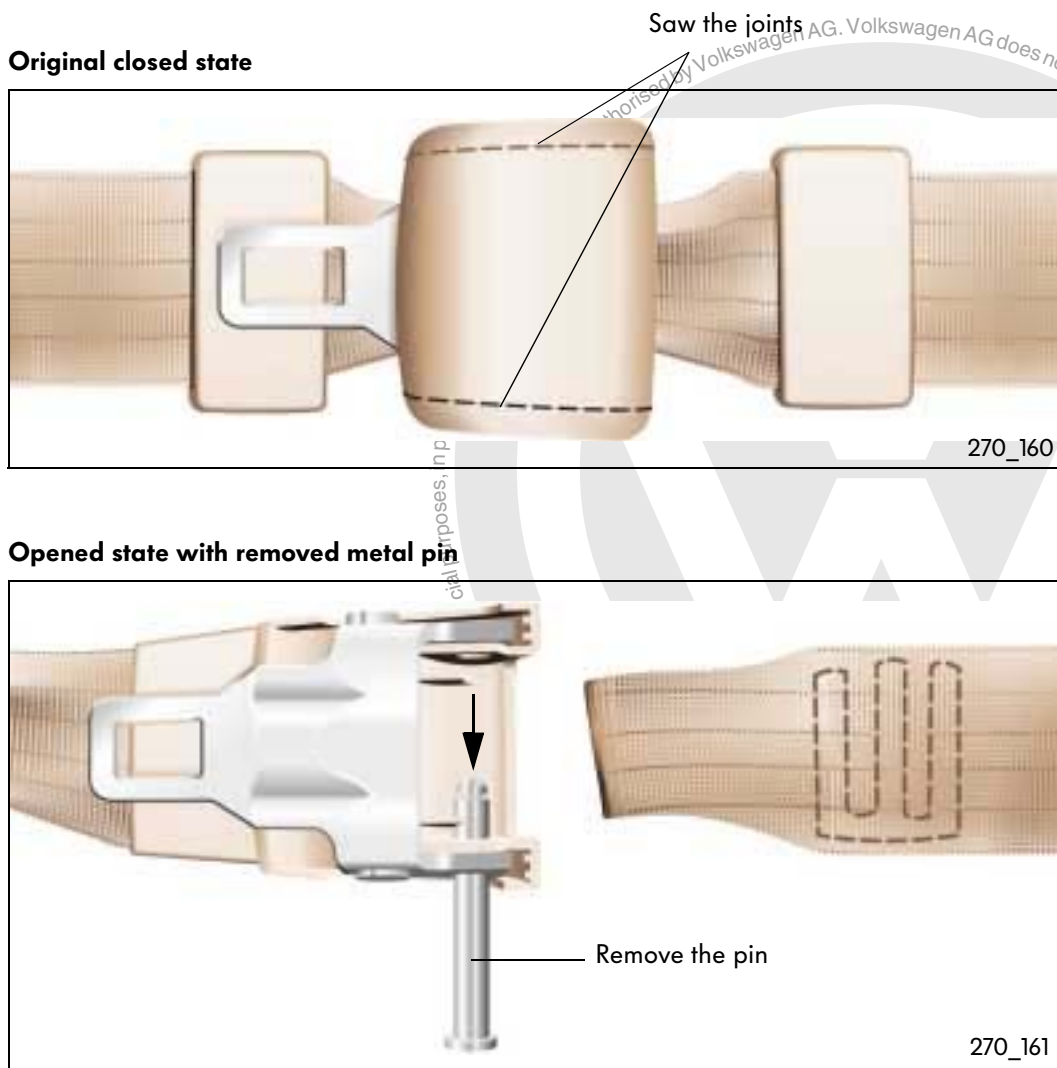

When carrying out assembly tasks on the lap-belt winders, please ensure that the underpart of the housing is not damaged!

If damage should occur, the complete lap-belt winder is to be replaced!

Engines

The Phaeton engines

The Phaeton is available with a choice between two petrol engines and one diesel engine.

The entry-level motor is a 3.2l V6 petrol engine. This motor is an advancement of the 2.8l V6 petrol engine.

The launch of the Passat W8 witnessed the introduction of a new Volkswagen engine series: W-engines. The absolute highlight of this engine

series — a W12 petrol engine with a 6.0l displacement — is available in the Phaeton. All petrol engines work with 4-valve technology and conform with the EU4 exhaust emission standard.

A 5l V10 TDI diesel engine with a pump-jet injection system is the top engine version available in the Phaeton.

It is the most powerful series passenger-vehicle diesel engine in the world.

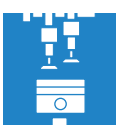

3.2l V6 petrol engine

6.0l W12 petrol engine

5l V10 TDI engine



270_142



270_056

270_058

The 3.2l V6 petrol engine

is an advancement of the Volkswagen 2.8l V6 engine. The construction principle of applying a narrow V-angle of 15°, and its associated advantages resulting in a low overall length and width, has been adhered to. The displacement increase to 3.2l, in conjunction with its first-ever longitudinal mounting in a vehicle, required a complete overhaul of the engine. The engine's increased displacement was rendered possible by extending the piston stroke while simultaneously augmenting the cylinder bores.



270_142

Innovations in engine mechanics with respect to the 2.8l V6 petrol engine

- Continuous intake and exhaust camshafts - adjusted by vane pump regulator
- Intake and escape channels with considerably increased flow capacity
- Inlet and escape valves with enlarged diameter
- Crankshaft with enlarged stroke
- Cylinder crankcase with larger bore
- Optimised variable intake manifold with pressure-regulated crankcase ventilation
- Water-cooled alternator
- Oil filter and cooler unit integrated in the engine bracket

Technical features of the “Bosch Motronic ME 7.1.1” engine management system

- Electrical throttle valve operation
- Constant Lambda regulation by 4 Lambda sensors with 2 pre-catalytic-converters and 2 post-catalytic-converters
- Control of the inner exhaust gas recirculation via the camshaft adjustment
- Secondary air injection
- European On Board Diagnostic System (EOBD) with exhaust gas indicator light
- Electronically-regulated fan control



Engines

Technical data 3.2l V6 engine

Engine code	AYT
Construction	VR engine
Displacement	3189 cm ³
Bore	84 mm
Stroke	95.9 mm
Compression ratio	11.25:1
Valves per cylinder	4
Max. output	177 kW at 6200 1/min.
Max. torque	315 Nm at 2400 1/min.
Engine management	Bosch Motronic ME 7.1.1
Fuel	ROZ 98 (reduced performance with ROZ 95)
Exhaust treatment	Three-way catalytic converters with constant Lambda regulation
Exhaust emission standard	EU 4

Torque and performance chart

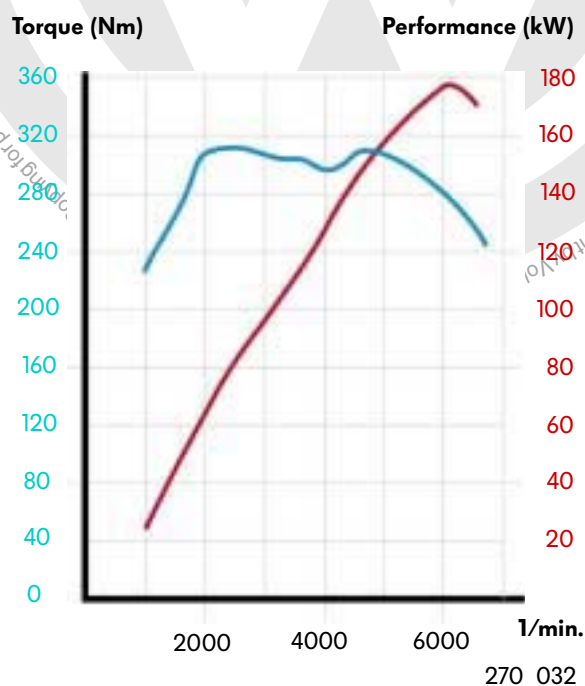

The 3.2l V6 engine achieves its maximum torque of 315 Nm at an engine speed of just 2400 1/min.

This facilitates changing up to the next gear at low engine speeds, thus increasing fuel efficiency.

The nominal output of 177 kW/241 bhp is achieved at 6200 1/min.

The 6.0l W12 petrol engine

With the W12 engine, Volkswagen is offering a 12-cylinder engine in its range for the first time ever. It is the most powerful engine version available in the Phaeton.



270_056

Engine mechanics technical features

- Cylinder block made of aluminium
- Bottom crankshaft bearing in grey cast iron bearing blocks
- Oil pump driven by a chain
- Very compact engine

Engine management technical features

- Two motor controllers
- Secondary air injection
- Exhaust gas recirculation

Technical data

Engine code	BAN
Construction	W engine
Displacement	5998 cm ³
Bore	84.0 mm
Stroke	90.186 mm
Valves per cylinder	4
Compression ratio	10.75:1
Max. output	309 kW at 6000 1/min.
Max. torque	550 Nm at 3500 1/min.
Engine management	Bosch Motronic M 7.1.1
Fuel	ROZ 98
Exhaust treatment	Three-way catalytic converter with constant stereo Lambda regulation
Exhaust emission standard	EU 4

Torque and performance chart

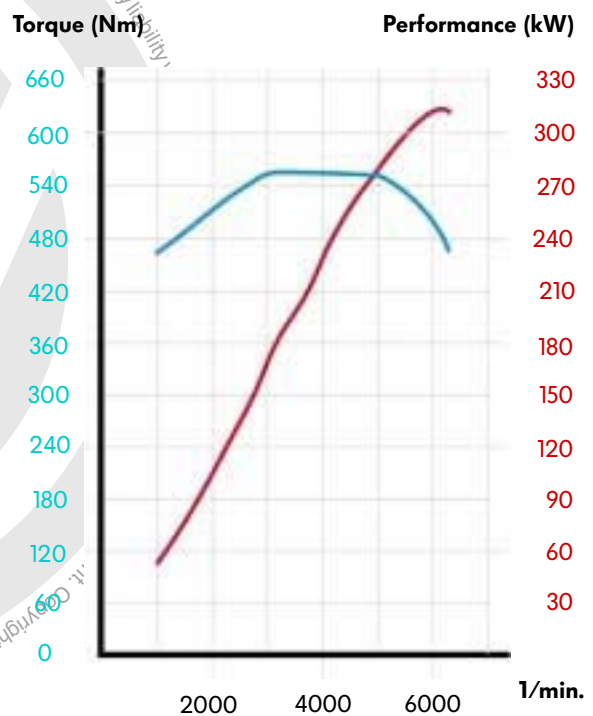

270_172



Please refer to the self-study programmes nos. 248 and 250 for detailed information on the W engine concept.

Engines

The 5l V10 TDI engine

The V10 TDI engine is a recently developed diesel engine. Combining an innovative lightweight construction with enormous power, it is equipped with the pump-jet injection system.



Engine mechanics technical features

- Cylinder block made of aluminium with a grey cast iron bearing tunnel
- Joining of cylinder head and cylinder block via tie-rod screw connection
- Balancer shaft for reducing vibrations
- Control and ancillary unit driven by gearwheels

Engine management technical features

- Two motor controllers
- Charged by two adjustable turbochargers
- Exhaust gas recirculation effected with pneumatically-controlled exhaust gas recirculation valves in conjunction with

270_058

Technical data

Engine code	AYH
Construction	V engine, 90° V-angle
Displacement	4921 cm ³
Bore	81 mm
Stroke	95.5 mm
Valves per cylinder	2
Compression ratio	18.5:1
Max. output	230 kW at 4000 1/min.
Max. torque	750 Nm at 2000 1/min.
Engine management	Bosch EDC 16
Fuel	Diesel 49 CZ min. or biodiesel
Exhaust treatment	Exhaust gas recirculation and oxidation catalytic converter
Exhaust emission standard	EU 3

Torque and performance chart

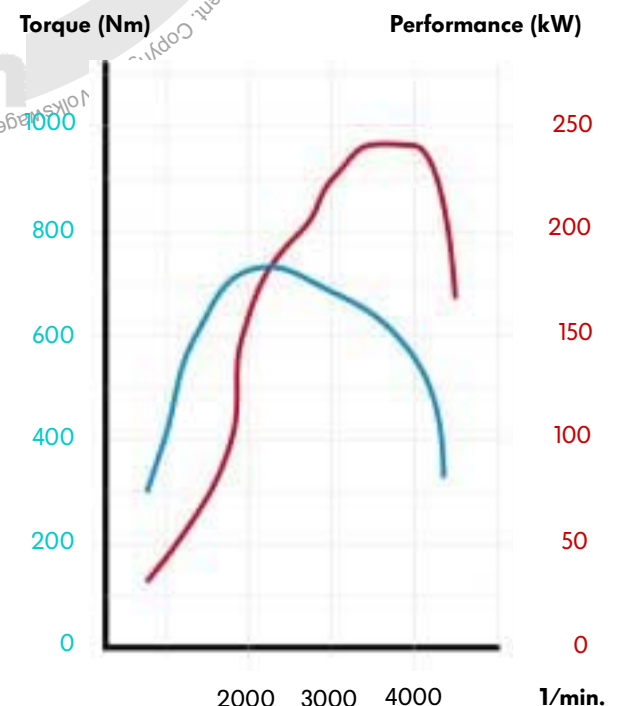

270_173

The fuel tank

The fuel tank is mounted on the vehicle's underbody close to the rear axle. It has a filling volume of 90 litres. Due to its external shape, it consists of a main and secondary chamber.

Both fuel tank chambers have an electrical fuel pump and a sucking-jet fuel pump.

Each electrical fuel pump is assigned two senders for fuel supply, a fuel sender and a lever sender.

The four senders for fuel supply directly transmit their signals to the dash panel insert.

Reserve tank
(only in vehicles with petrol engine)

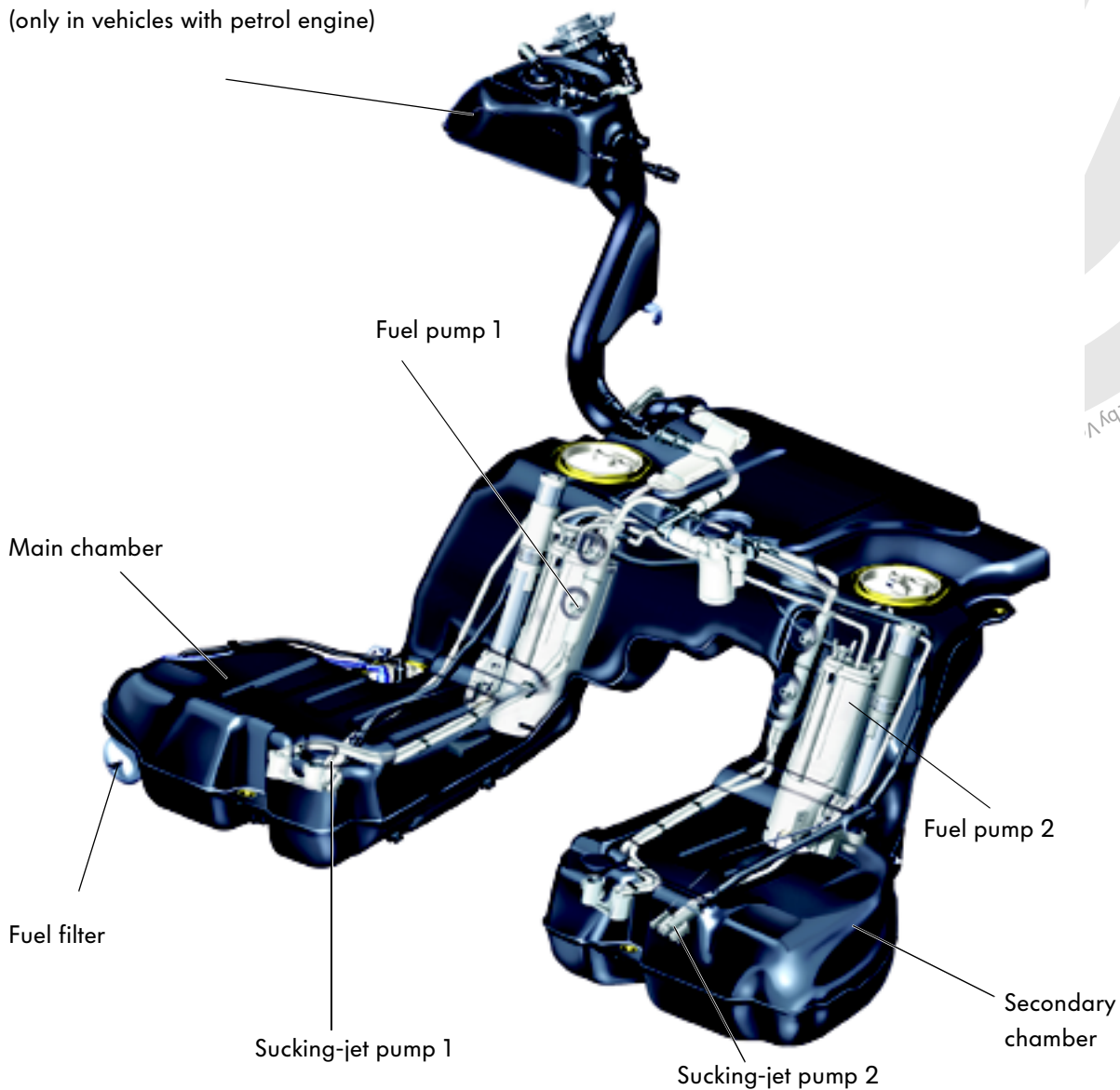

Automatic transmission

The automatic transmission

Depending on the engine, the Volkswagen Phaeton is fitted with one of two 5-speed automatic transmissions or a 6-speed automatic transmission.

The 5-speed automatic transmission

Both 5-speed automatic transmissions are currently already in use in other vehicles from the Volkswagen Group. They have been modified and adapted for installation in the Phaeton. An electronic/hydraulic system is used for controlling the two automatic transmissions.

To this end, the automatic transmission's control unit registers operating conditions, the driver's wishes as well as external influences such as travelling uphill or downhill. Shifting between the 5 gears is effected by the control unit with regards to all incoming data.

Furthermore, both 5-speed automatic transmissions have:

- a dynamic shift programme and also a sport programme,
- a regulated torque converter lockup clutch,
- and a Tiptronic shift programme with steering wheel switches.

The 5-speed automatic transmission 01V

Installed in the front-wheel drive Phaeton in conjunction with the

- 3.2l V6 engine.

Maximum torque transmission: 310 Nm



270_104

The 5-speed automatic transmission 01L

Installed in the Phaeton 4-Motion with the

- 6.0l W12 engine.

A Torsen centre differential (PAT) is integrated in the gearbox in order to distribute the torque to all four wheels.

Maximum torque transmission: 560 Nm



270_105

The 6-speed automatic transmission

The Phaeton is the first Volkswagen vehicle to be fitted with a 6-speed automatic transmission. The specially-developed automatic transmission is installed in the Phaeton in conjunction with the new 5l V10 TDI engine with 4-Motion.

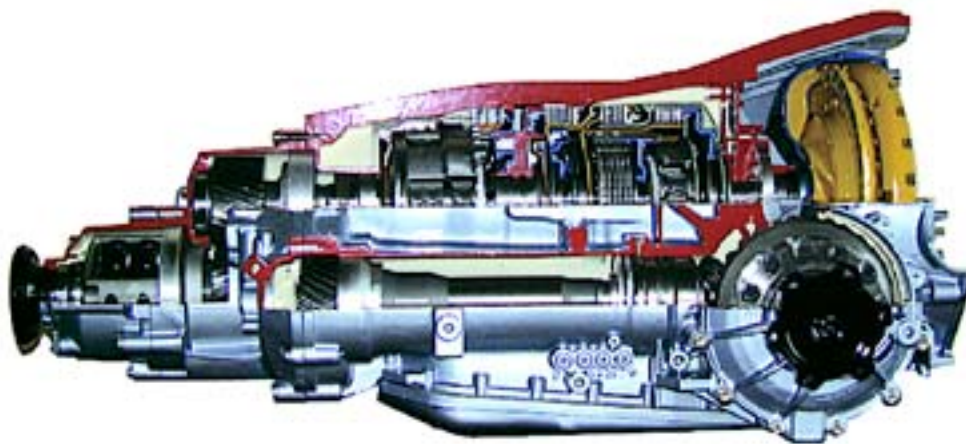

270_135

Compared with the 5-speed automatic transmissions, it is especially characterised by:

- an improved driving performance,
- a reduction in fuel consumption and exhaust emissions,
- a weight reduction of approx. 14 kg,
- a reduction in the number of components by approx. 30% and by a high shifting spontaneity with excellent shifting quality.

Technical features

Gearbox description:	09F
Max. input torque:	750 Nm

Furthermore, the automatic transmission has:

- a dynamic shift programme and also a sport programme,
- a regulated torque converter lockup clutch and
- a Tiptronic shift programme with steering wheel switches.



Automatic transmission

The six automatic transmission gears are shifted via a Ravigneaux planetary gear set with a series-connected simple planetary gear set. This arrangement is known as the Lepelletier gear-set concept.

Lepelletier gear set

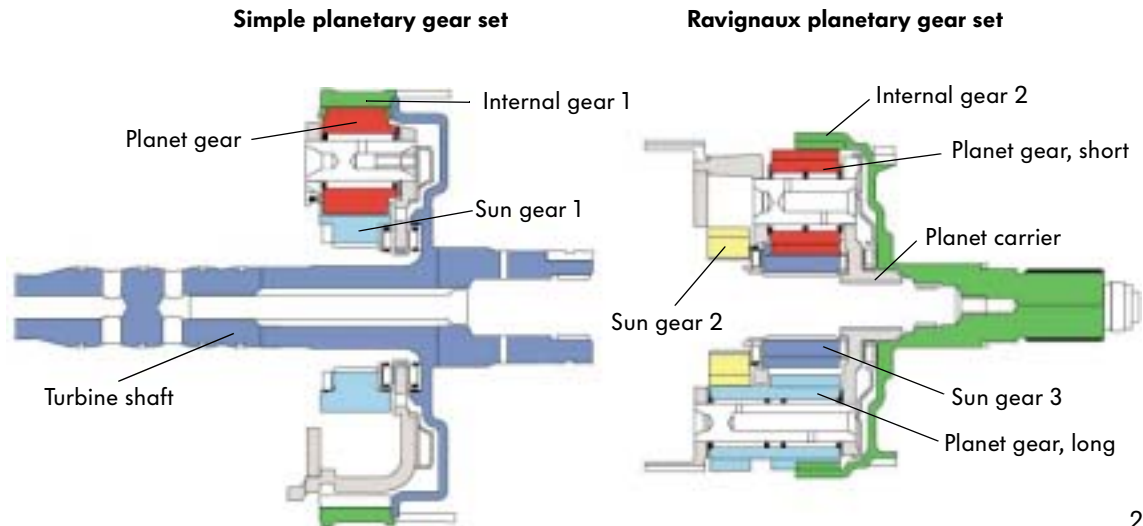

270_221

Control of the automatic transmission is effected by a control unit known as mechatronics. This is a combination of an electronic control unit and a hydraulic switching device (control valve assembly). Gear changes can be controlled more exactly than before due to mechatronics. This provides drivers with an optimised shifting quality and an increased level of driving comfort. Using the

incoming sensor signals, the control unit recognises the current state of the gearbox and the driver's intention, reacting to these with adjusted shift points. Driver wishes ranging from an extremely sporty to a very economical driving style are recognised and taken into consideration. Mechatronics is arranged within the gearbox, located directly at the control valve assembly.

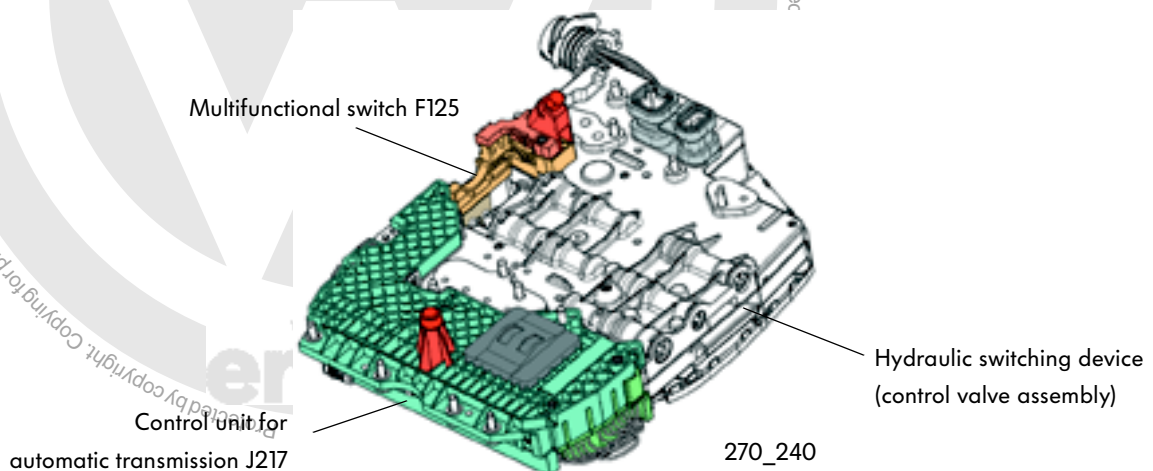

270_240

Selector lever positions

The selector lever and Tiptronic functions are the same in the 5-speed automatic transmission and the 6-speed automatic transmission.



P - Parking

In order to move the selector lever from the 'P' position, the ignition has to be turned on and both the brake and the selector lever's locking key have to be pressed.

R - Reverse

The brake and the selector lever's locking key have to be pressed in order to apply the reverse gear.

N - Neutral

The gearbox is idling in this position. No power is being transmitted to the wheels.

D - Automatic gear changing

When the selector lever is positioned at 'D', gear change from gear 1 to 5, or gear 1 to 6 in the 6-speed automatic transmission, is effected automatically.

S - Sport

In this selector lever position, the automatic transmission shifts according to sporty characteristics. The gears are extended further and the shift points occur at higher engine speeds.



Automatic transmission

Shift programme and gear indicator in the dash panel insert

In both the 'D' and 'S' automatic shift programme, the engaged selector lever position and the gear being currently used are displayed in the dash panel insert.

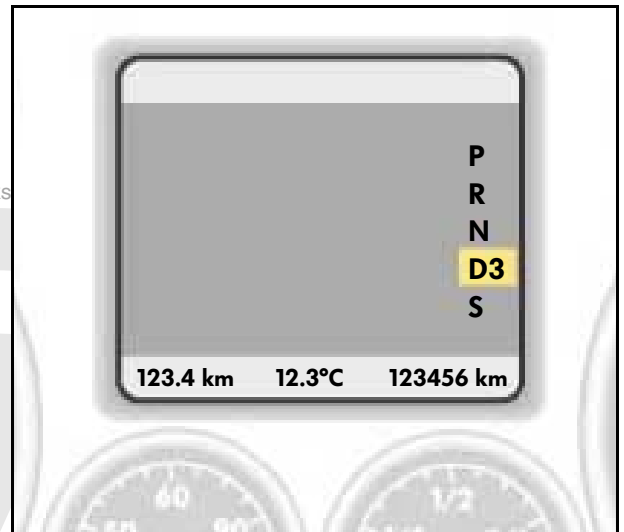

270_109

The respective gear being used is displayed in the dash panel insert if the automatic transmission is in the Tiptronic shift programme.



270_108

Tiptronic

The Phaeton's Tiptronic is available as a selector-lever Tiptronic and also comes with switches on the steering wheel for operating the Tiptronic.

Selector-lever Tiptronic

The automatic transmission is switched to Tiptronic mode by moving the selector lever from the 'D' position into the Tiptronic aisle.

Gear change now has to be effected by moving the selector lever.

Moving the gear-shift lever forward switches up a gear, moving it back moves down a gear.



270_029

Steering wheel - Tiptronic switches

These steering wheel switches, which have been tried and tested in the world of motor sport, offer an optimally ergonomic actuation for gear selection. Here you use:

- the switch on the right to move up a gear and
- the switch on the left to move down a gear.

If the selector lever is in the 'D' or 'S' positions when the steering wheel switches are pressed, the automatic transmission control moves into Tiptronic mode. Control automatically reverts to the previously selected 'D' or 'S' programme if the steering wheel switches are not pressed again.



270_096



Automatic transmission

The selector lever block

The magnet for selector lever block N 110

is located on the selector lever frame below the selector lever. It prevents the actuation of the selector lever from the positions 'P' and 'N' when the brake is not being applied.

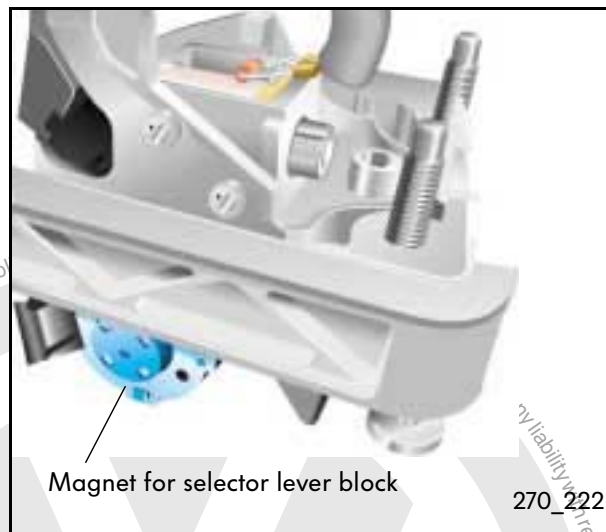

How it works

Once the ignition has been turned on, the magnet for the selector lever block is put under current by the control unit for automatic transmission, thus blocking the selector lever. If the control unit receives the signal 'brake applied', it cuts off current to the magnet and the selector lever can be moved.

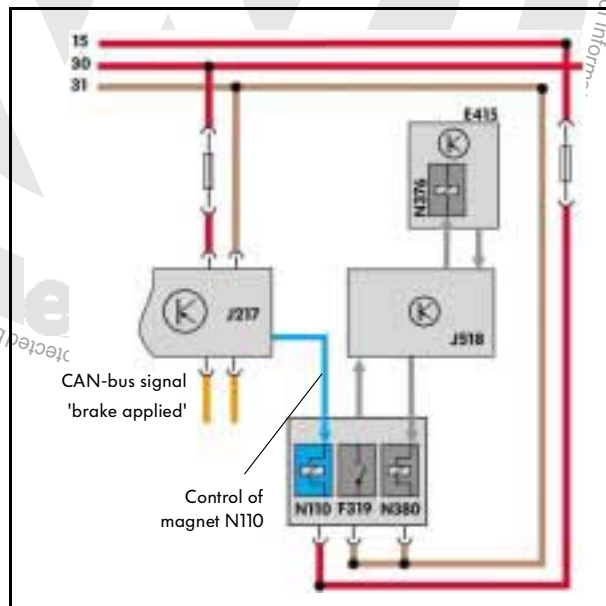

Effects of drop-out

If one of these two signals fails or if the magnet is faulty, the selector lever can be moved out of 'P' and 'N' without applying the brake — when the ignition is turned on.

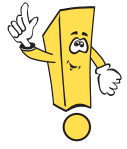

The magnet for selector lever block 'P' N380

Also located at the selector lever. It prevents the selector lever from moving out of the 'P' position when the ignition is switched off. The brake therefore has to be pressed and the ignition switched on in order to move the selector lever from the 'P' position.



It is possible to switch on the ignition via the switch for access and start authorisation and via the button E408 for access and start authorisation.

How it works

The magnet for selector lever block 'P' is without current when the ignition is switched off, thus disabling the selector lever in 'P' position. Once the ignition has been switched on, a signal flows from the switch for access and start authorisation E415 or from the button for access and start authorisation E408 to the access and start authorisation relay J 518. This then sends current to the magnets for selector lever block 'P' and the disablement is removed. The switch F319 signals to the access and start authorisation relay that the selector lever is in 'P' position.

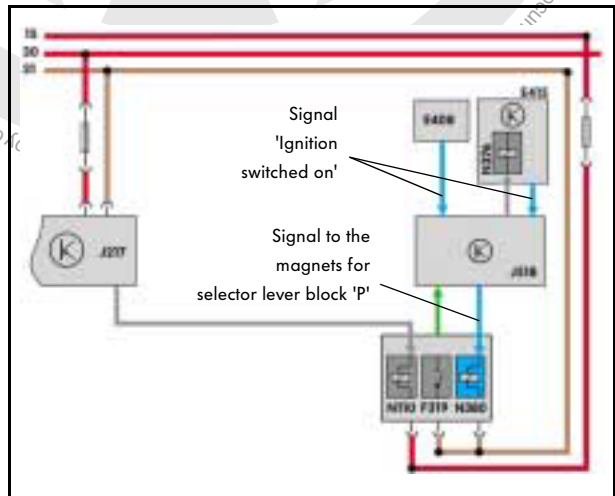

270_225

Effect of drop-out

If one of the signals fails or the magnet for selector lever block 'P' is defective, then the selector lever cannot be moved out of the 'P' position. The disablement has to be manually unlocked for towing the vehicle. For this purpose, the selector lever covering is to be removed and the magnet actuated by hand. The selector lever has to be simultaneously moved out of the 'P' position.

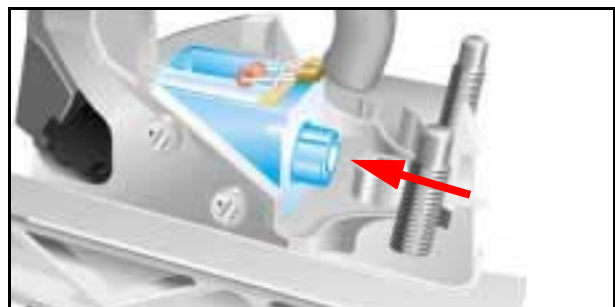

270_157



Automatic transmission

The magnet for ignition key pull-out lock N376

It is located within the switch for access and start authorisation E415 and prevents the ignition key from being removed when the selector lever is in a driving position. Compared with the previous mechanical systems (by cable control), the ignition key pull-out lock in the Phaeton operates on an electromechanical basis.

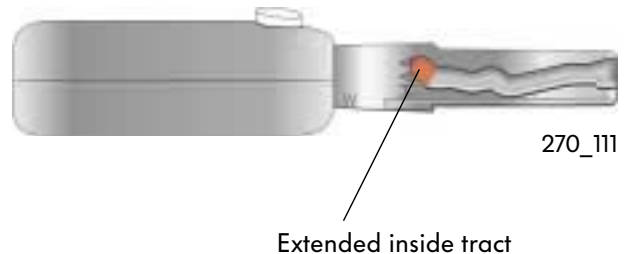

How it works

The ignition lock contains two spring-loaded locking pins which engage in the extended inside tract of the inserted ignition key. The locking pins engage in the extended inside tract of the ignition key if the selector lever is not in 'P' position. The ignition key cannot be withdrawn.

Without current

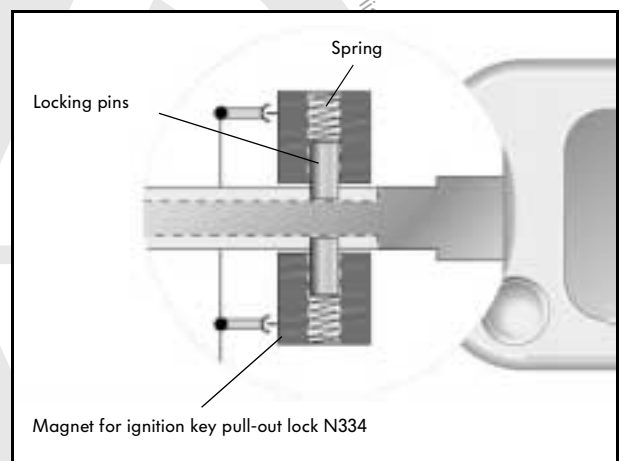

Under current

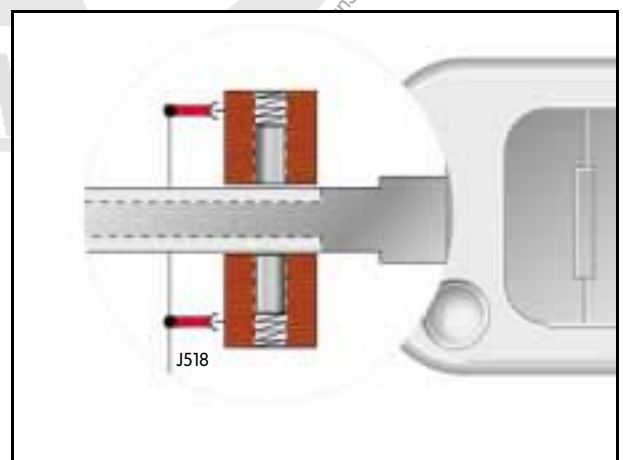

When the selector lever is in 'P' position, a signal travels from the switch for selector lever in 'P' F319 to the access and start authorisation relay J518. The control unit then sends current to the magnet for the ignition key pull-out lock. The locking pins are pulled out by the magnets and thus removed from the extended inside tract of the ignition key. The ignition key can be withdrawn.



If the vehicle is equipped with a Start/Stop button, the driver receives a visual and acoustic warning upon leaving the vehicle if the selector lever is not in the 'P' position.

Manual gearbox

The 6-speed manual gearbox FWJ

The 6-speed manual gearbox has already proven itself as the basic gearbox for the front-wheel and four-wheel drives in the engines longitudinal mounting.

In the Phaeton, it is deployed as the front-wheel drive gearbox in conjunction with the V6 engine. In order to maximise convenience of use, actuation by means of a control cable is used instead of a linkage gearshift. An appropriate support has been specially developed on the gearbox housing for the control cable mounting and for the actuation of the shifter shaft in the gearbox.

The ends of the cable are attached with locknuts to the steering levers. Mass dampers support the shifting movements and absorb vibrations.

In order to adjust the control cables, the gear-shift lever is locked in place in the left neutral position by the adjustment drift T10027 when the shift cables are loosened.

A stopping drift is located on the bearing housing of the shifter shaft end on the gearbox housing. This is turned to the right in order to secure the shifter shaft in the left neutral position. The cable ends can now be attached again.

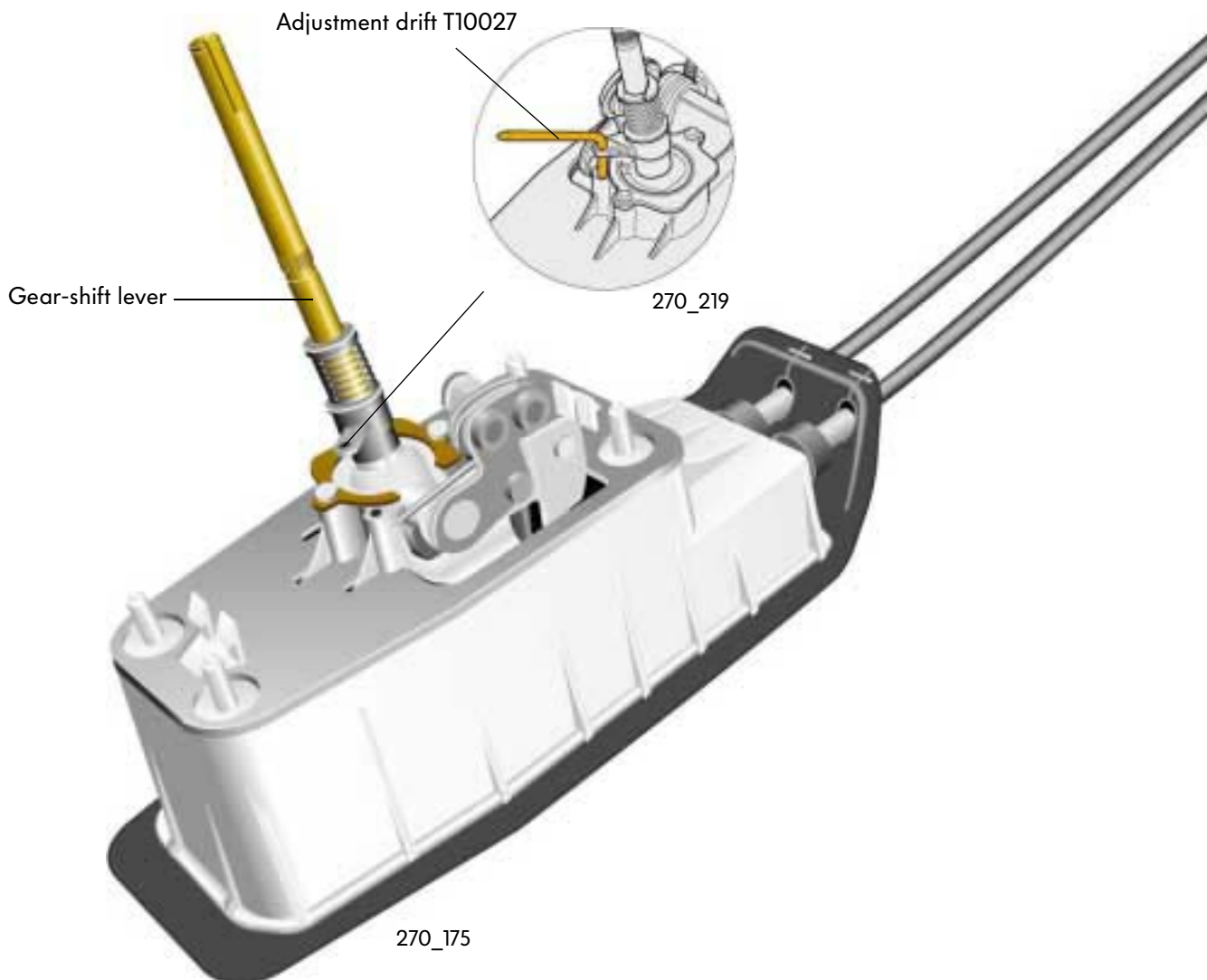

is not permitted unless authorised by Volkswagen AG. Volkswagen AG does not guarantee or accept any liability with

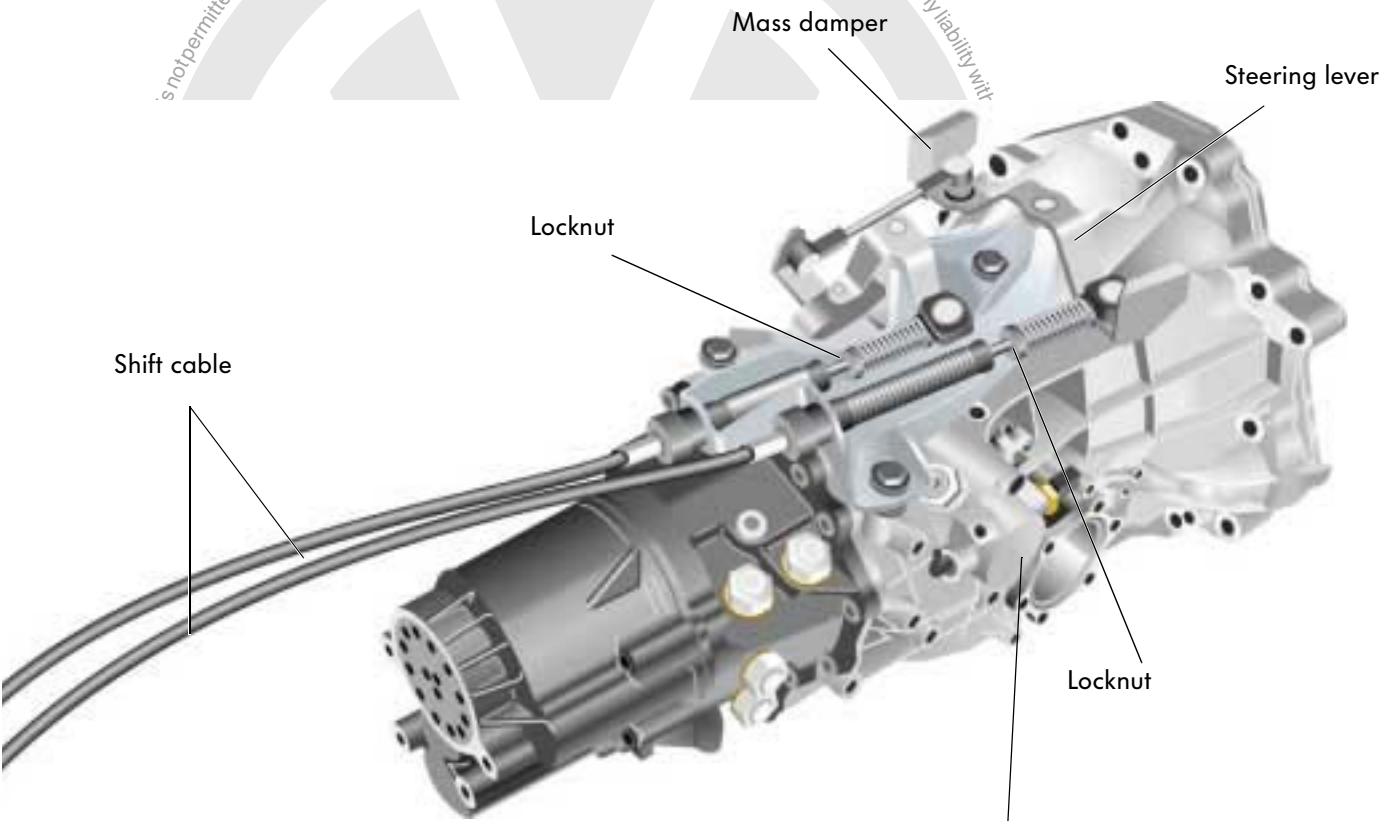

270_176

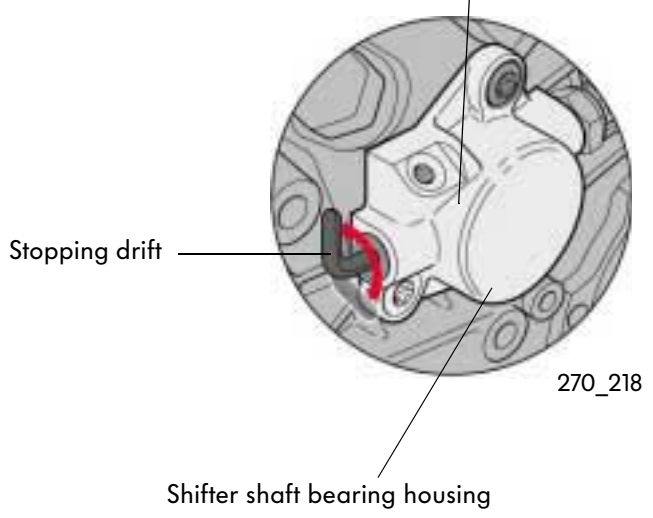

Chassis

The chassis in the Phaeton

The chassis with front-wheel and 4-motion drive is combined with a 4-corner air suspension. This facilitates an extremely sensitive activation of the suspension even on slightly uneven driving surfaces.

Electrically adjustable steering column with electrical steering column locking

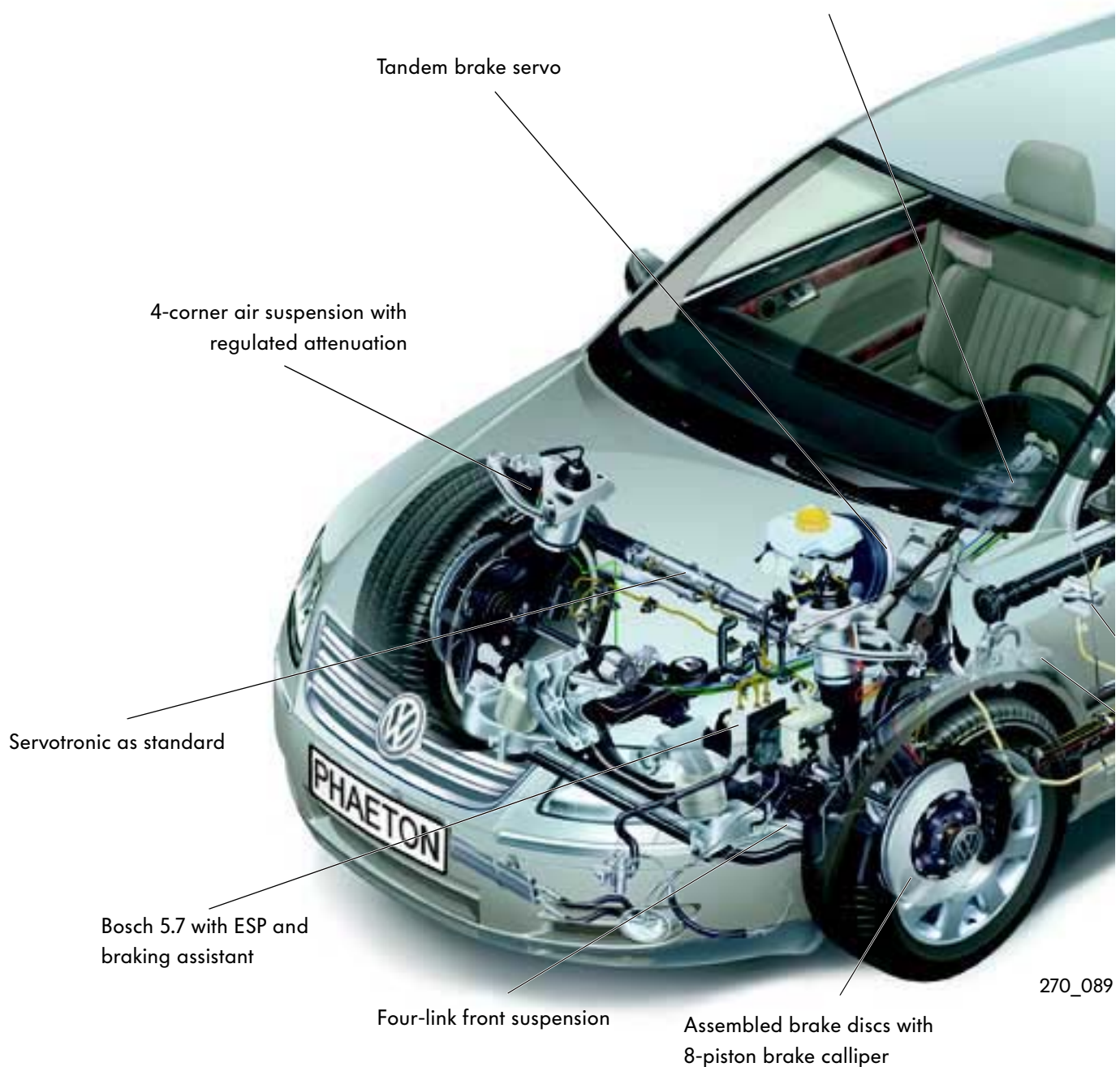

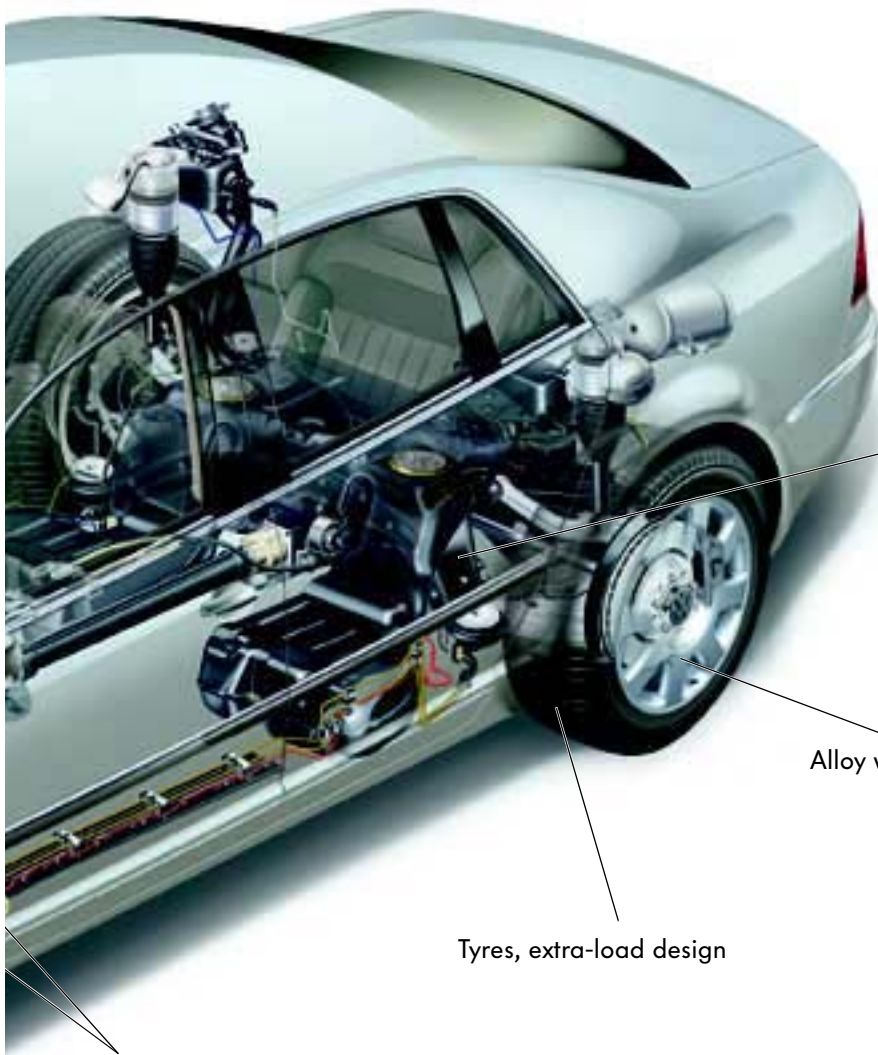

Volkswagen AG. Volkswagen AG does not guarantee or accept any



respect to the correctness of information in this document. Copyright by Volkswagen AG.

Trapezoidal wishbone rear suspension for front-wheel and four-wheel drive

Alloy wheels

Tyres, extra-load design

Foot parking brake with mechanical loosening device in the dash panel



The chassis is described in detail in SSP 277 "Phaeton - The Chassis".

270_090

Convenience electronics

The memory functions

The vehicle offers a large variety of memory functions which are saved and accessed via various operating panels. In addition to the functions controlled via the seat memory, user settings can be created using the ignition key with radio-wave remote control.

These user profiles communicate via the main information display and operating unit and the access and start authorisation relay.

Seat memory

Component	Storable components/functions
Driver's seat	Seat settings: Longitudinal adjustment, inclination adjustment, backrest inclination, height adjustment, legrest adjustment, backrest head adjustment, headrest adjustment, vertical and horizontal lumbar support, outside mirror, remote control, steering column (height and length adjustment), seatbelt height and interior mirror
Front passenger seat	Seat settings: Longitudinal adjustment, inclination adjustment, backrest inclination, height adjustment, legrest adjustment, backrest head adjustment, headrest adjustment, vertical and horizontal lumbar support, seatbelt height
Rear seats (left / right)	Seat settings: Longitudinal adjustment, inclination adjustment, vertical and horizontal lumbar support, headrest

Main information display and operating unit

Component	Storable components/functions
Air-conditioning system	Air-conditioning functions right / left, front / back, air recirculation automatic operation, solar ventilation and weekly timer for auxiliary heater
Telephone	Activating the telephone functions: caller display
Navigation	Display (map / symbol), route options, announcements (on / off), traffic jam alert
Audio - TV	Preselection of radio station, CD, TV and volume, GALA, sound settings
Settings	Units of measurement, volume, system language and settings for orientation illumination (fade-out time)
Vehicle	Tyre pressure control, spare tyre monitoring
Board PC	Choice of representation (from start, until destination, long-term)



The graphic below provides an overview of the controls and their associated memory function components. Please consult the appropriate chapters for a more precise description of the main information display and operating unit controls and for information regarding seat adjustments.

Overview of memory components

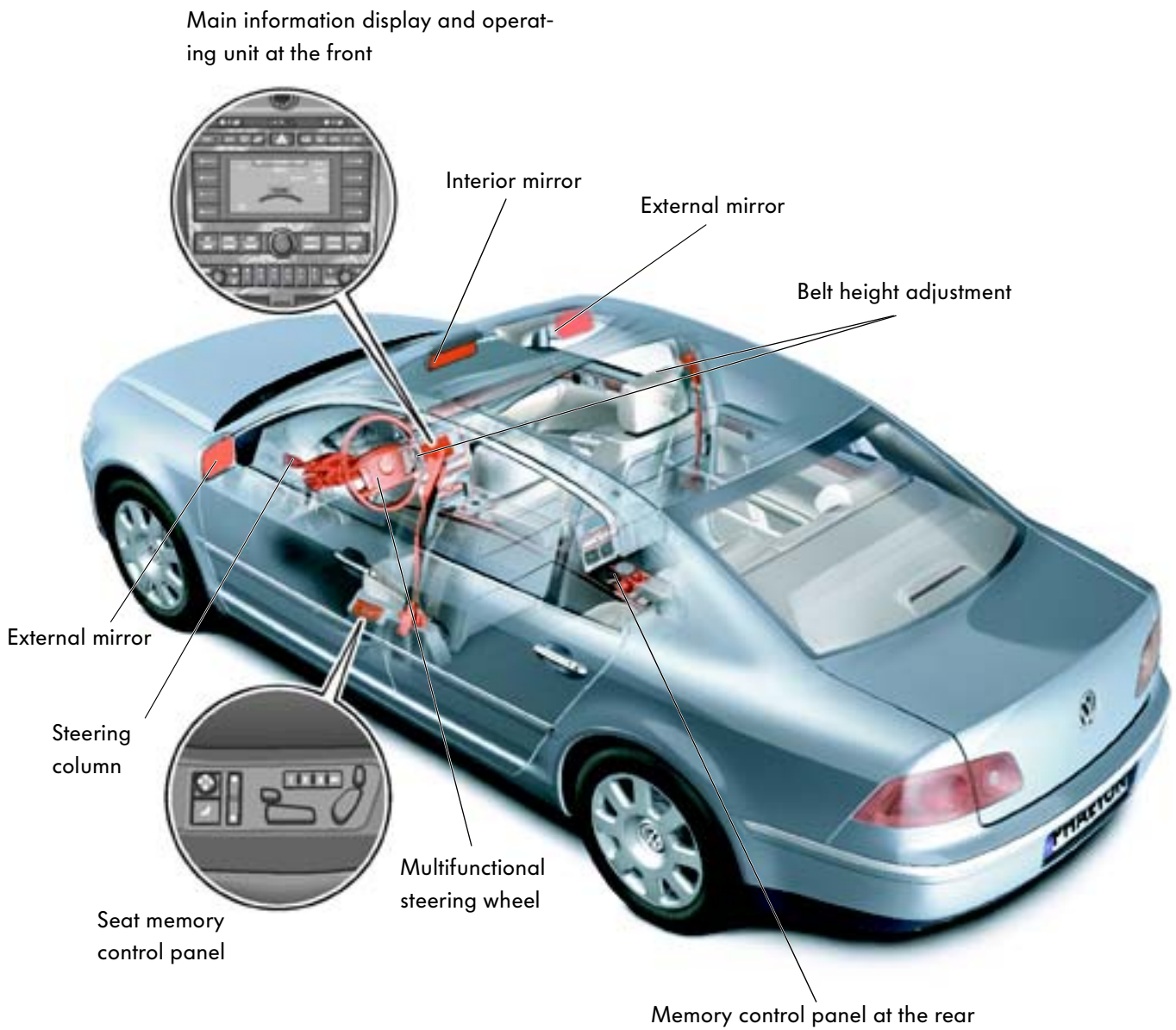

270_208

Convenience electronics

The access and start authorisation system

The vehicle can be locked or unlocked and the engine can be started or switched off, without the active deployment of the radio-wave remote control ignition key, by using the optional comfort features of the access and start authorisation system.

The components and functions listed in the table are constituent parts of the access and start authorisation system.

Ignition key with radio-wave remote control	Radio-wave remote control as before, the access and start authorisation relay analyses the radio signals; central locking functions via the central control unit for the convenience system; tailgate remote control
Electromechanical steering column locking (ELV)	Locking and unlocking of the steering column when inserting and removing the key by the access and start authorisation relay, ELV is off-circuit as long as the key is neither removed nor inserted, ignition can be activated only when the steering column is unlocked
Switch for access and start authorisation	Automatic resetting of the ignition key to the neutral position after switching on the engine, electrical pull-out lock: each key mechanically fits into the switch for access and start authorisation and can be rotated; ignition occurs only once the ignition key has been identified by the access and start authorisation relay
Immobiliser III	Immobiliser III as before, acting together with the switch for access and start authorisation, the engine control unit and the ELV
Softstart	Via the CAN data bus drive and the access and start authorisation relay; also for prolonged stops in the starting position (terminal 50 on), in the switch for access and start authorisation the starter is engaged only until the engine is running - leading to improved starter protection and less noise
Fitting positions for access and start authorisation components	Access and start authorisation relay: left footwell under the carpet Switch for access and start authorisation: on the right of the steering wheel Electromechanical steering column locking: steering column Rear antennae: bumpers Shift-shaft antenna: shift-shaft covering panel Tunnel antenna: rear tunnel on the cable channel Central armrest antenna: rear seat central armrest / ski-bag cover Hat rack antenna: modular hat rack Button for access and start authorisation: shift-shaft covering panel Electronic door handles: external door handles



Please consult self-study programme 273 “The Phaeton - Convenience and Safety Electronics” for further information on “Access and start authorisation”.

Convenience electronics



270_209



Additional functions of the comfort features for access and start authorisation

Vehicle access without active deployment of the ignition key	Opening with radio-wave remote control using antenna and sensor in the external door handle, key identification by the access and start authorisation relay, unlocking via central control unit for the convenience system and door control unit
Starting the engine without active deployment of the ignition key	Ignition key check in the vehicle interior via interior antennae, starting the engine with the button for access and start authorisation, unlocking the steering column with the access and start authorisation relay once ignition key has been positively identified
Turning off the engine without active deployment of the ignition key	Pressing the button for access and start authorisation
Vehicle locking without active deployment of the ignition key	Pressing the locking button in the external door handle

Automatic distance control (ADC)

ADC is a driver-assistance system which enhances cruise control.

By reducing motor torque and the possible application of the brake, an ADC-vehicle is kept at a convenient distance behind a slower-moving vehicle in front.

Its function is clarified by the four traffic scenarios presented below.

Steady speed

There are no vehicles driving ahead within the distance-regulator sensor's detection area. The driver's desired speed is maintained.

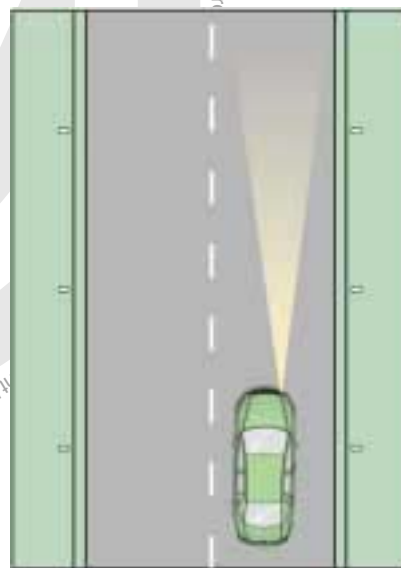

100 km/h

270_197

Delay

When the ADC-vehicle approaches a slower-moving vehicle, speed is slackened by reducing the engine torque and, if necessary, through a moderate application of the brake. The driver is prompted to take over the braking operation if the delay is insufficient.

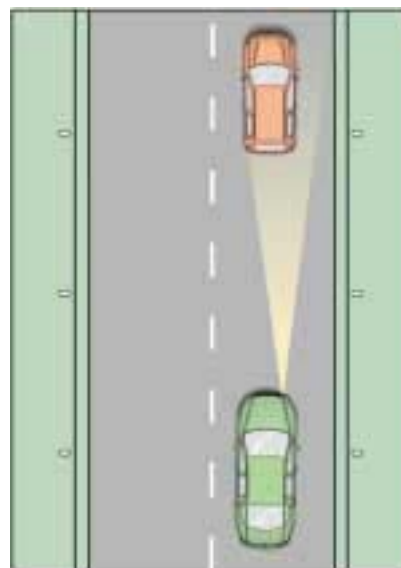

80 km/h

100 km/h
→ 80 km/h

270_198

Effects

The ADC-vehicle adapts itself to the speed of the vehicle in front.

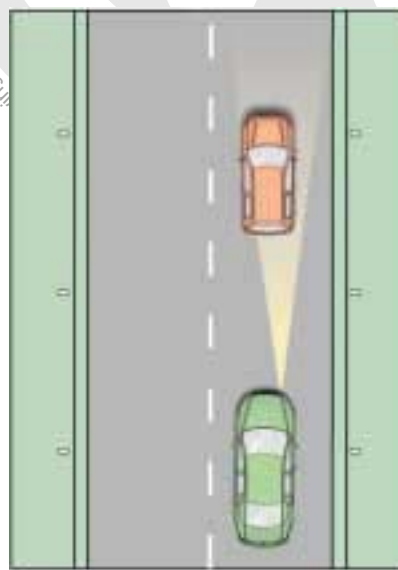

270_199

Acceleration

The ADC-vehicle accelerates to the desired speed once the vehicle in front leaves the traffic lane or the detection area.

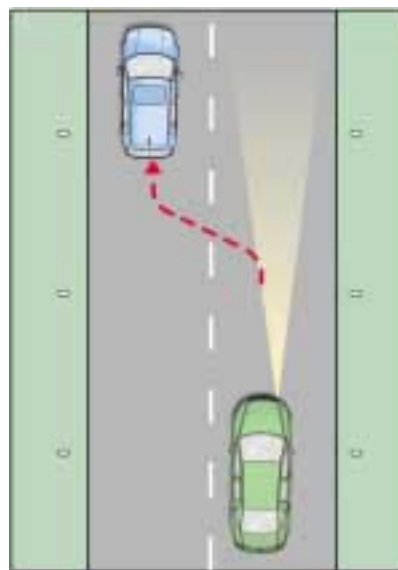

270_200



Electrics

Conditions for switching on and off the ADC

ADC system status is influenced by the left bank of buttons on the multifunctional steering wheel, the accelerator, the brake pedal, the selector lever, as well as by the engagement of the vehicle's built-in braking system.

The ADC system is always in a 'non-ready state' when the engine is started and has to be switched to stand-by by pressing the ON/OFF key.

Switching on

The ADC system can be switched on at a driving speed of between 30 and 180 km/h.

The keys have the following functions:

- The SET key adopts the current speed as the desired speed. Repeated pressing reduces the desired speed by 1 km/h each time.
- The RES key adopts the previous desired speed. Repeated pressing increases the desired speed by 1 km/h each time.
- The +GRA key or the -GRA key increases or reduces the desired speed in increments of 10 km/h.

Switching off

- ON/OFF key, desired speed is lost
- CANCEL key, desired speed is maintained
- Stepping on the brake pedal
- Excessive application of the accelerator
- Selector lever in P, R, N
- Driving speed outside of the range of 30 to 180 km/h
- Application of ESP, ASR, MSR, ABS



270_201

New components

The ADC function is made possible by the deployment of a distance sender in accordance with the radar principle and by an active electronic brake servo.

Important data regarding the distance control sender include:

Transmit frequency:	76.5 GHz
Visual range:	150 m
Horizontal viewing angle:	12 °
Vertical viewing angle:	4 °
Speed measuring range:	± 180 km/h

The electronic brake servo is a well-known tandem amplifier in which an integrated electro-magnet controls the pressure distribution in such a manner that approx. 30% of the braking force can be activated electrically.

The necessary braking convenience is ensured by a brake pressure control with a separate sender for brake pressure and a membrane position control with a separate membrane position sender.

The electronics associated with the amplifier are accommodated in the control unit for braking force amplification.

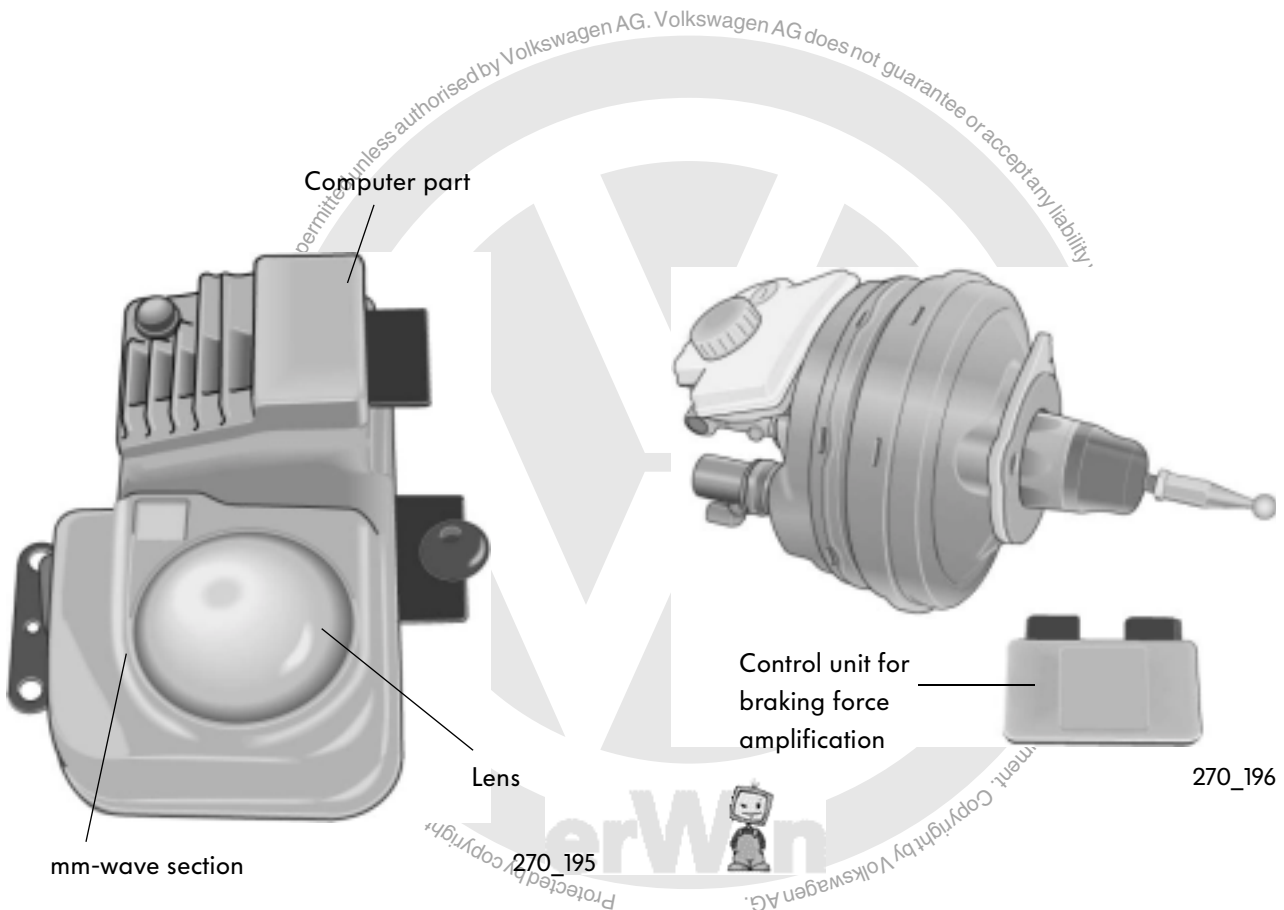

Electrics

Headlights

Various headlight designs are available. The basic equipment consists of an xenon headlight with gas discharge lamps for the dipped beam and a HB 3 lamp for the high beam.

Double xenon headlights are available as an optional extra with the V6 engine or W12 engine series. With this system the dipped beam and high beam light is generated by gas discharge lamps.

A gas discharge lamp for high beam is also turned on when switching from dipped beam to high beam light.

The indicator lights are integrated in the headlight; the H21W bulb is not visible under the covering.

This makes possible a level of homogeneity which is unique for such unusual dimensions.



270_237



The gas discharge headlights are diagnosis-capable via the VAS 5051 measuring and diagnostic system.



Fog lights

The fog lights are built into the bumper. They are based on reflection technology with a H11 lamp and a transparent cover disk.

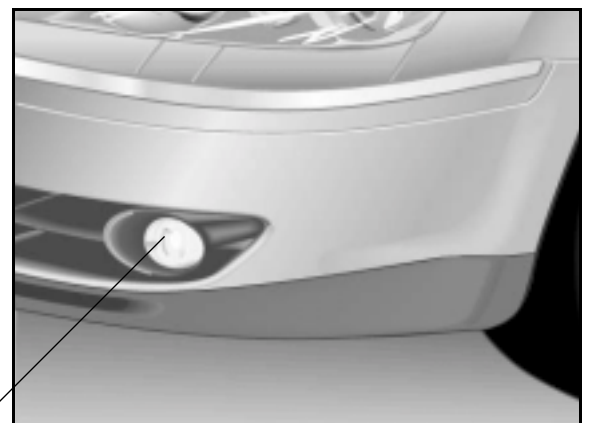

Fog lights

270_238

Rear lights

The rear lights are designed with light-emitting diodes (LED). Lower energy consumption, shorter response times and a longer service life are among the advantages.

A malfunction is detected in the event of the LEDs becoming defective. The driver receives notification of the problem in the dash panel insert.



270_236

Brake light

Red glass with rear fog lights
26 LEDs 13.5 V 5.7 W

Without rear fog lights
90 LEDs 13.5 V 13 W

Rear fog lights

Red glass
48 LEDs 13.5 V 9.7 W

Rear light

Red glass
123 LEDs 13.5 V 1.8 W
90 red LEDs 33 red/yellow LEDs

Direction indicator

Red glass
33 LEDs 13.5 V 8.9 W

Reversing lights

Clear glass
Bulb HPL 13.5 V 16 W



Electrics

Battery design

The battery has the task of guaranteeing the electrical energy for starting the engine and of feeding the electrical consumer units. One battery is not sufficient for fulfilling this requirement in all models.

In order to ensure a sufficient energy supply for the electrical consumer units and the starter, a

- one-battery on-board network and a
- two-battery on-board network are deployed.

One-battery on-board network

Vehicles with

- V 6 engines

are fitted with one battery.

The electrical consumer units are supplied by one battery in all operating conditions.



The repair instructions on the subject of battery removal and installation are to be observed in order to avoid malfunctions in some electrical components after a complete voltage failure.

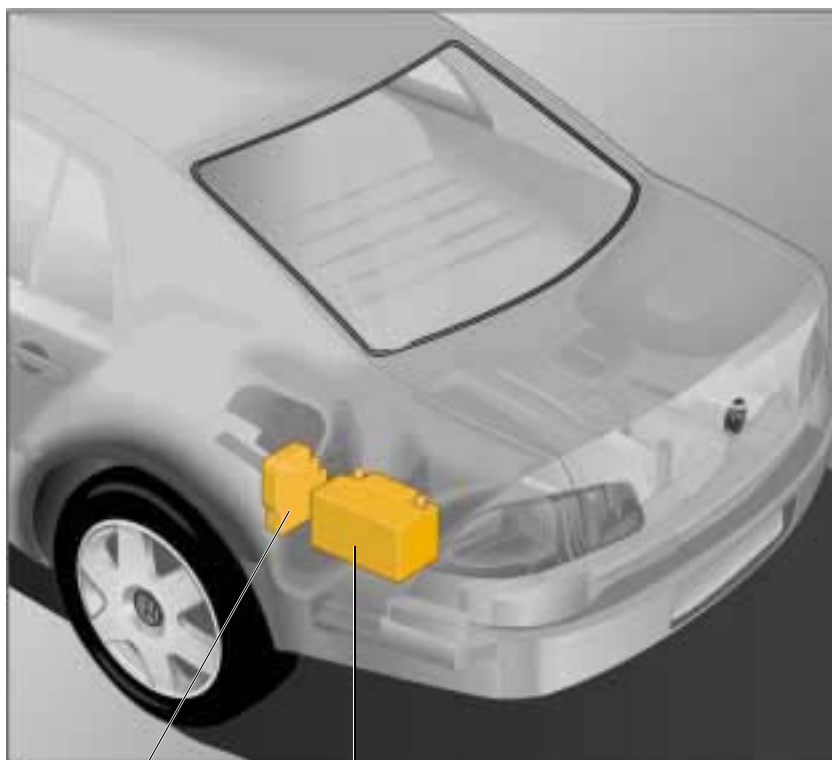

Series fuse box

Battery

270_232



Two-battery on-board network

Vehicles with

- W 12 and
- V 10 TDI engines

Additional feature for vehicles with

- V 6 engines

The two-battery on-board network consists of a starter battery, an on-board network battery, a relay for parallel wiring battery (J581) and a battery monitor control unit (J367).

The starter battery feeds the starting current circuit for starting the engine; the on-board network battery feeds the 12V on-board network.

Starting with a discharged on-board network or starter battery is possible. Control is effected via the battery monitor control unit and the relay for parallel wiring battery.

Both batteries are wired in parallel at temperatures below 0°C in order to satisfy the cold start requirements of the V10 TDI engine.

Protected by copyright. Copying for commercial purposes, in part or in whole, is not permitted unless authorised by Volkswagen AG. Volkswagen AG does not guarantee the accuracy of the information.



Starter battery

On-board network battery

Relay for parallel wiring battery

Series fuse box

270_231

Battery monitor control unit



Electrics

Jump-start

Starting with an external voltage source is possible if the battery in a one-battery on-board network is discharged or both batteries in a two-battery on-board network are discharged. The voltage source may only be attached to the starter side terminal 30a at the jump-start connection.

This method only supplies consumer units relevant to the starting procedure and protects the on-board network.



270_230



Please observe the safety instructions in the workshop and operating manuals.

Adjusting headlights

The headlights have to be locked in place in the 'basic setting' function prior to adjustment with the measuring and diagnostic system 5051. Mechanical access to the headlight adjustment is opened via the control unit for front information display and operating unit (J523).

Changing the wiper blades

To change the wiper blades, they first have to be moved into the service position via the control unit for front information display and operating unit, 'Maintenance & Service' function.

The service position can only be reached by observing particular preconditions. Please observe the instructions in the applicable workshop manuals.

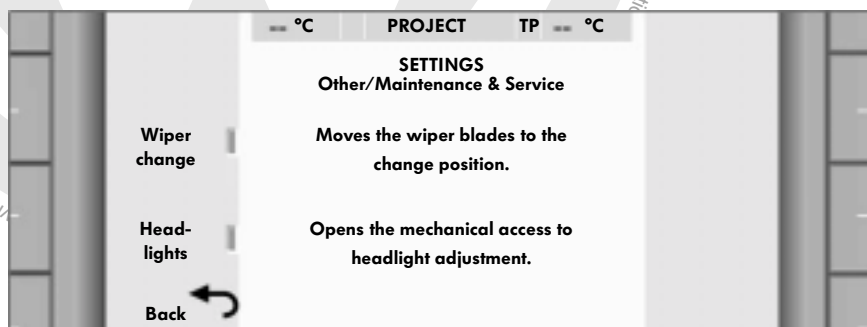

270_235

Battery

The on-board network battery is maintenance-free due to the use of non-woven fabrics containing latent sulphuric acid. The cells' fill plugs cannot be opened. The emerging gases are fed into the wheel housing via a lateral outlet and a supply pipe.

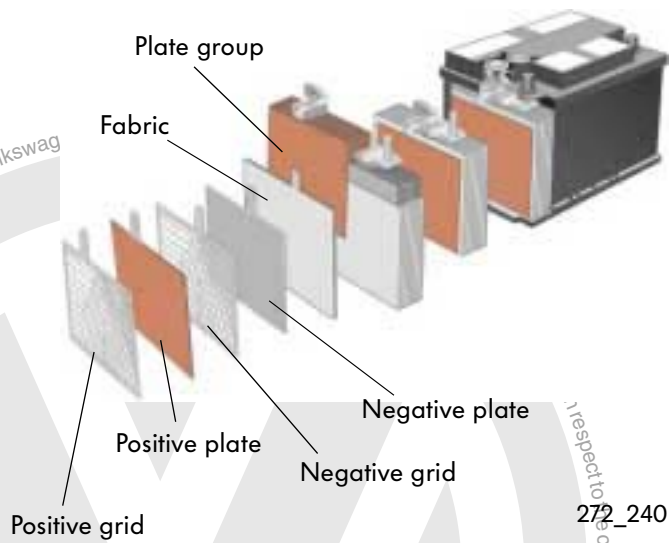

272_240

Safety battery terminal

In the event of a crash, the starter battery's battery lead is separated pyrotechnically from the battery. The trigger thresholds are dependent on the gravity of the accident and on the direction of impact and they are stored in the airbag control unit.

Non-triggered system

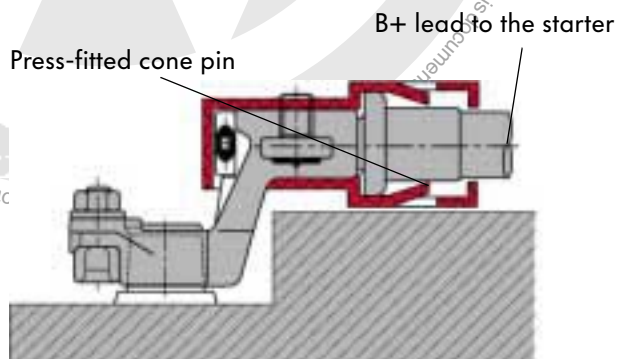

Triggered system

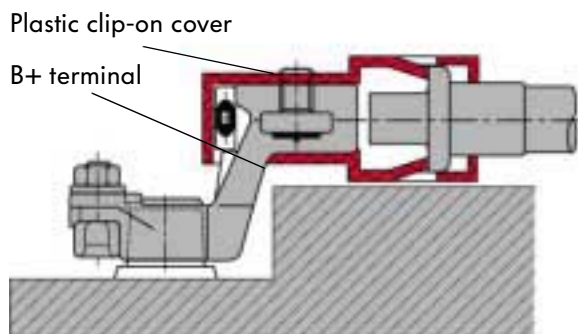

270_233



Heating/air-conditioning system

The 4C Climatronic

As a luxury-class saloon, the Phaeton has a four-zone air-conditioning system as standard. Thanks to the 4C Climatronic (4 corners), both the driver and passengers can enjoy their own desired air-conditioning settings independently of each other. The temperature range available is between 18 °C and 28 °C.

The air-conditioning system is controlled via the Infotainment with the air-conditioning row and the 'AC' main-menu button.

Pressing this button calls up the main air-conditioning menu on the Infotainment's display.

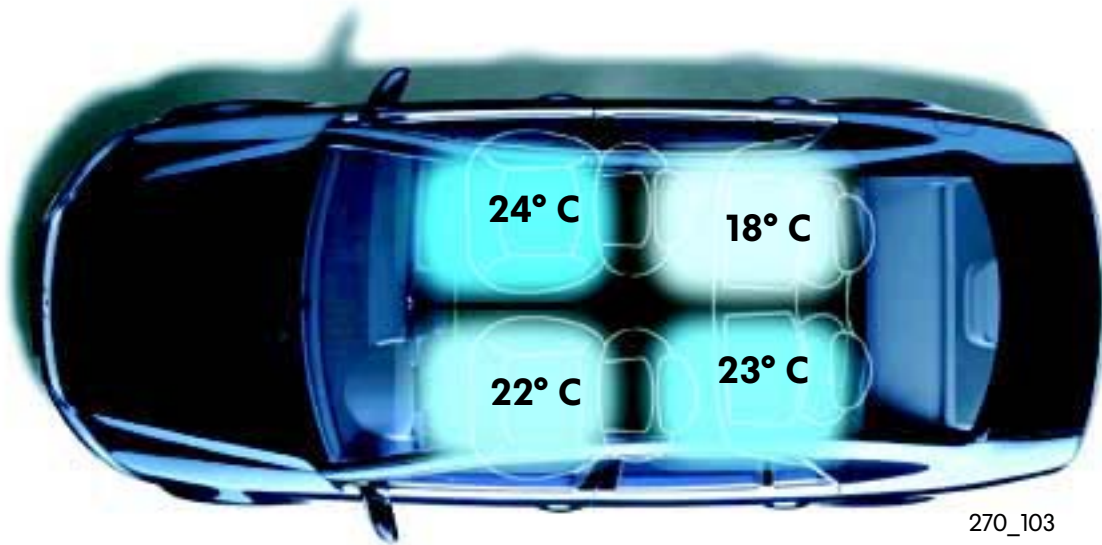
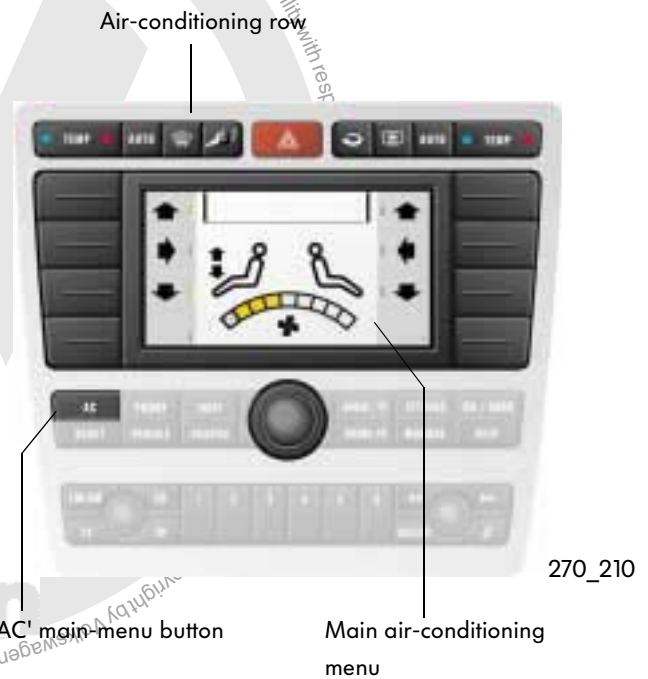

More comprehensive and detailed information on the heating and air-conditioning system can be found in self-study programme 271.

Special functions

- Automatic and manual air-conditioning control for each air-conditioner zone
- Air-conditioner synchronisation: all air-conditioner zones will be tuned to the settings of the driver's seat
- ECON function
- Automatic and manual recirculating air function with air-quality monitoring
- Automatic and manual defrost function with window-mist recognition
- Provision for direct sunlight during climatic regulation



If the Phaeton is equipped with the optional extra of an electrical windscreen heating, this will also be switched on or off via the button for manual defrost.

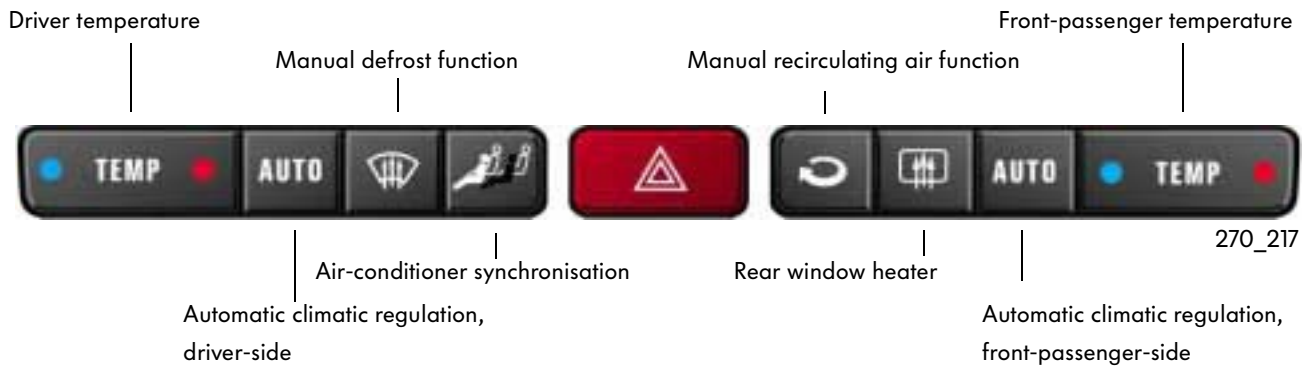

Heating/air-conditioning system

Air distribution in the vehicle

The blower sucks in fresh air through the dust and pollen filter and conducts it to the vaporiser. The airflow in the air-conditioning device is separated for the first time behind the vaporiser: the main part flows through the heat exchangers and a smaller part bypasses the heat exchangers and is fed to the air flaps in the air-conditioning device.

Its structural design with two adjacent heat exchangers results in a right-left distribution for the ventilation of the vehicle's interior.

The temperature of both of these airflows for the left and right-half of the vehicle is to a great extent determined by the temperature settings for the front seats.

The subsequent division of the air behind the heat exchangers to the individual air outlets is effected by electro-mechanical flaps on the air-conditioning device and in the dash panel.

In doing so, the air for the outlets in the B-pillars and for the rear footwell air outlets can be heated further with additional heating elements.

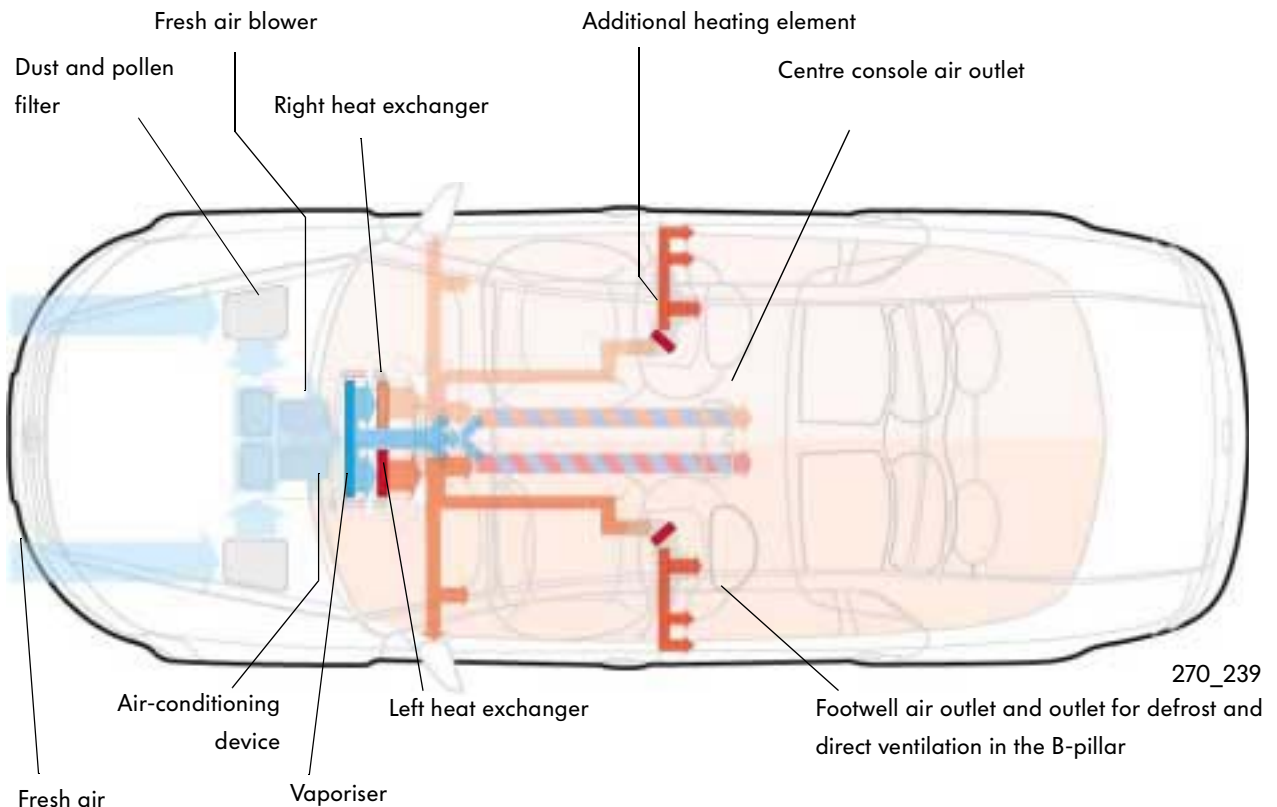

The structural features

The heating/air-conditioning system can be subdivided into the following categories:

- Cooling circuit with the sender for coolant pressure and temperature G395 and the temperature sensor vaporiser G308,
- Heating circuit with pump valve unit, two independent heat exchangers regulated on the water-side, as well as the two temperature sensor heat exchangers G306 left and G307 right,
- Sub-assemblies for air distribution with an air-conditioning device for realising the four air-conditioner zones,
- Display and operating units at front and back,
- Climatronic control unit.

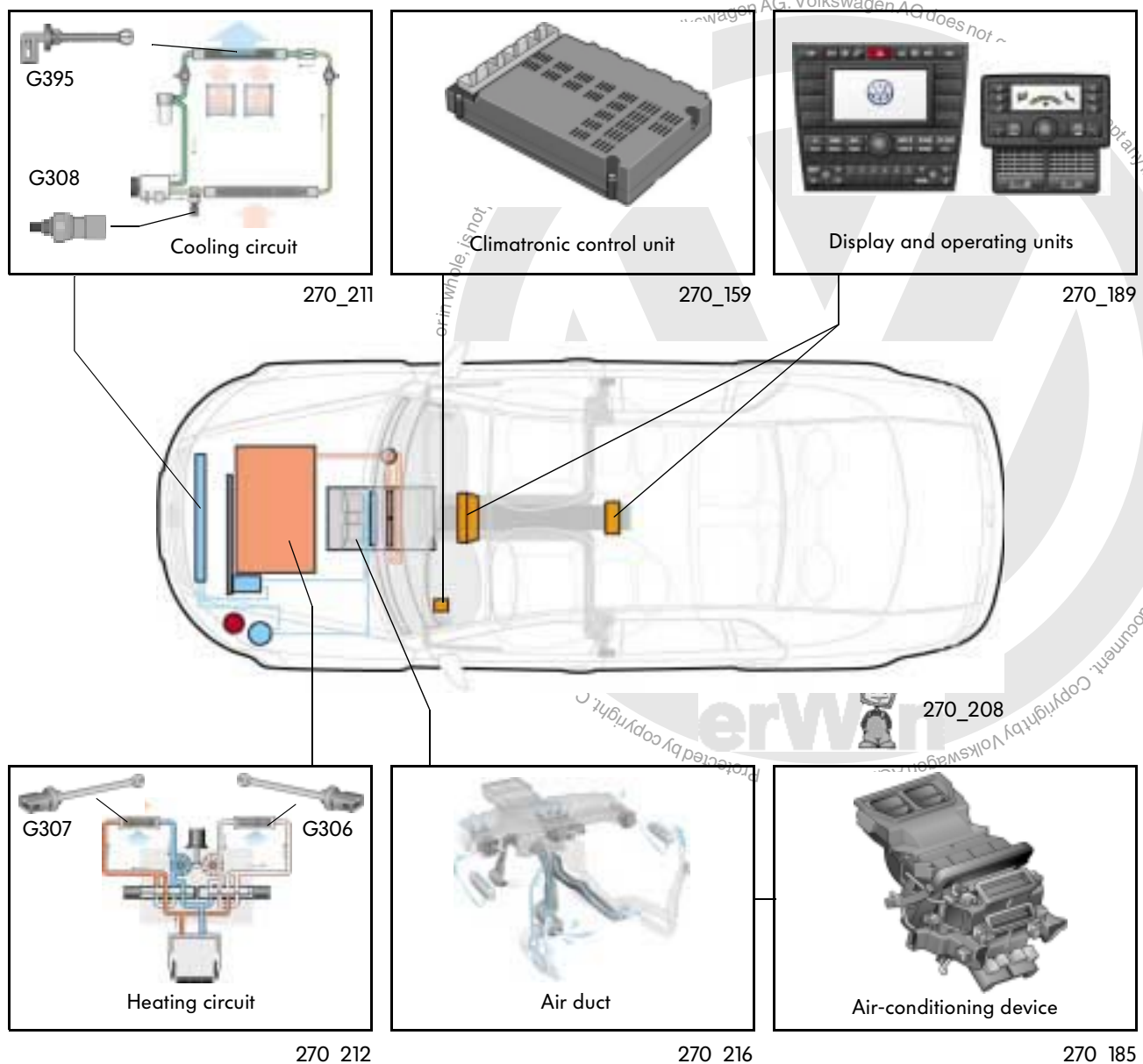

Infotainment



The Infotainment system

The Phaeton Infotainment system supervises a range of functions which can be controlled via the operating units in the dash panel and on the steering wheel and by a Climatronic display and operating unit at the back. Please consult SSP 274 for more detailed information on the Phaeton Infotainment.

Infotainment functions are:

- Audio (**AUDIO/TV**)
(Radio, CD player, Television),
- Telephone (**PHONE**)
(Mobile phone, Address-book management),
- Navigation (**NAVI**)
(Destination guiding, Destination information),
- Telemetry (**TRAFFIC**)
(Traffic jam alert, Alternative routes),
- Travel data (**BOARD-PC**)
(Distance data, Consumption, Fuel stop),
- Air conditioner (**AC**)
(Regulating heating/air-conditioning system, Solar roof function, Auxiliary heater),
- Setting variations (**SETTINGS**)
(Wiper blade change, Headlight setting, Voice control, Service functions)
- Tyre pressure control (**VEHICLE**) and
- Chassis settings
(Level and shock absorber control).

Infotainment cockpit operating unit



270_086



In addition to the operating units in the cockpit, steering wheel and at the back, the Infotainment system is essentially composed of:

- the display in the dash panel insert,
- the navigational processor with CD-ROM and CD player in the glove compartment,
- the antennae in the rear window and
- the microphone for voice control and telephoning.

The microphone is built into a front console in the roof lining.

These main elements are interlinked in the CAN data bus Infotainment.

This data bus network is one of a total of three CAN data bus networks in the Phaeton:

- CAN data bus drive
- CAN data bus convenience and
- CAN data bus Infotainment.

All three networks exchange information with one another. Infotainment can therefore access a wide range of sensors and actuators.

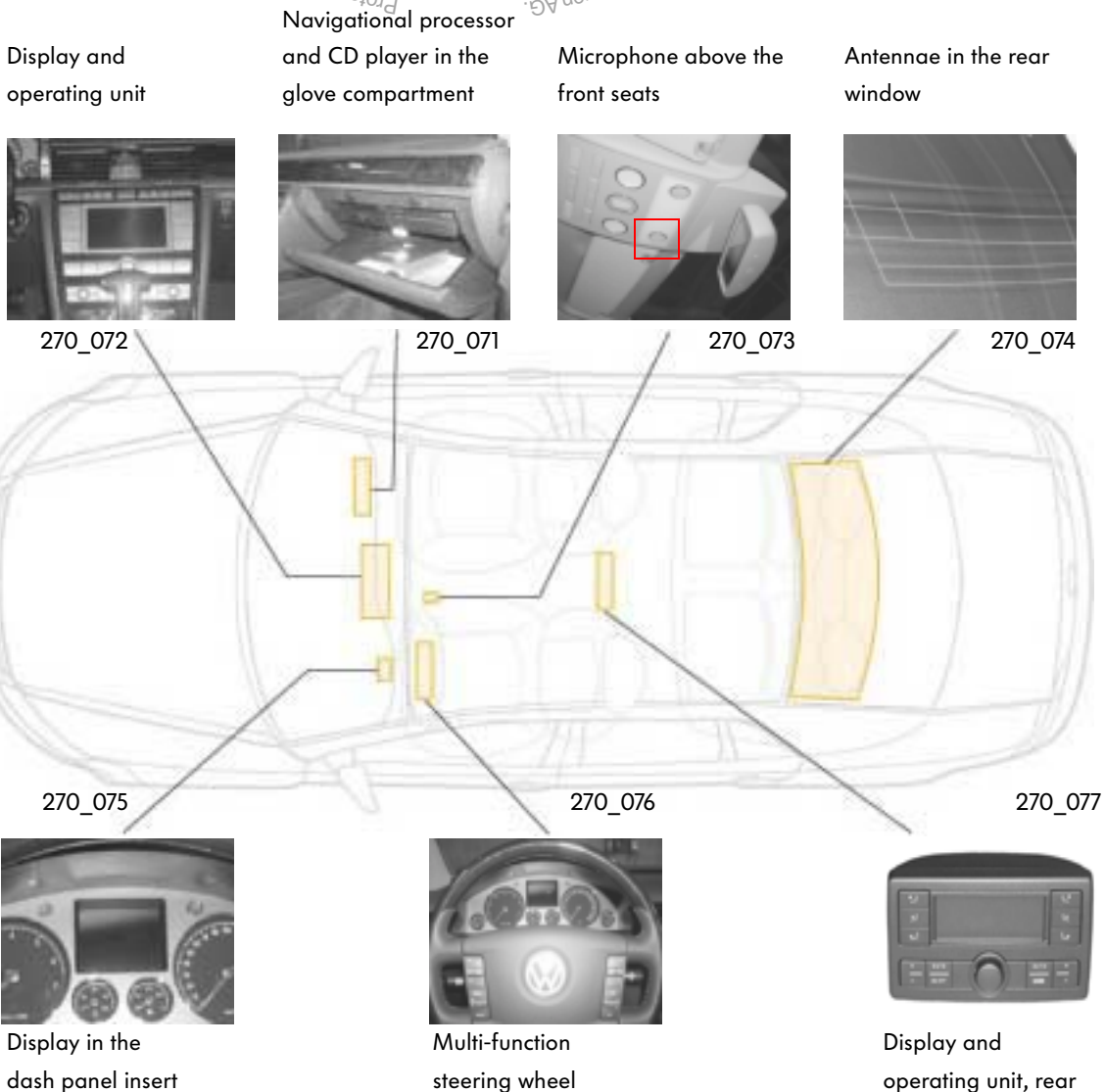

Infotainment

Display and operating unit, front



270_068

The display and operating unit is integrated into the centre console and is subdivided into various sections:

Air-conditioning row

Its keys have set functions for controlling the heating/air-conditioning system.

Function buttons with display

The various menus and information are shown on the display. The function of the buttons is menu-dependent and it is shown on the display as a lateral inscription.

Main menu row with knob / button

The selection of the main menu is made with this row's buttons. Menu items, e.g. from the address list, are selected using the knob / button and the selection is confirmed by pressing the button.

Audio row

Here you can change between radio, CD player and television. The selection of transmitting stations or volume, for example, is made using the appropriate buttons.

Steering wheel control

In addition to the horn, the inside of the multifunctional steering wheel accommodates two keypads for actuating the following functions:

- Cruise control system (GRA),
- Automatic distance control system (ADC),
- Infotainment subfunctions,
- Menu selection for the display in the dash panel insert, as well as
- Voice input activation.



270_067

The dash panel insert display

Some versions are also equipped with a 3" monochrome display or a 5" colour display. They can display 7 different menus for the various Infotainment functions.

In doing so, the displayed function from a menu list can be selected. A menu is selected via the multifunctional steering wheel. The display in the display and operating unit at the front is not affected by this selection.



270_069

Controls for the display control at the steering wheel



270_070



Inspection service innovations

- Inspections after every 60,000 km or after four years for the petrol engines
- Oil change in versions with the flexible service interval display after approx. 30,000 km or after 15,000 km in versions with a non-flexible display
- New VW oil standard 503 01 for W12
- Replace ATF oil after 30,000 km in the W12
- Replace gearbox top mounting in the W12 (with automatic transmission and towbar) after 150,000 km
- To replace the window wiper blades, move them into the service position via a menu item in the main display and operating unit.
- To adjust the headlights, move the headlight washer jets into a service position via a menu item in the main display and operating unit.

New special tools for Phaeton expertise centres

- Engine hoist VS 6100
- Engine and gearbox bracket VAS 6095
- Bracket for seat repair VAS 6136
- Upholsterer tool set VAS 6137
- Scissor lifting table VAS 6131
- Adapter for V.A.G. 1342
- Exhaust gas analyser probe VAS 1787/7A
- Exhaust gas analyser probe VAS 1788/13A
- Adapter for remote control V.A.G. 1348/3-3
- Cooling system filling device VAS 6096
- Fill plug set VAS 6122
- Upgrade set for PAX tyres VAS 6134/1
- Attachment set VAS 6130
- Portal calibre supplement VAS 5007/14
- Mudguard protector / front covering VAS 6133
- Masking film for dash panel VAS 1474/18
- ADC adjustment appliance VAS 6041
- Compression tool for buckle assembly T10150







Only for internal use © VOLKSWAGEN AG, Wolfsburg

All rights reserved

140.2810.89.20 Issued 03/02

 No chlorine was used to bleach this paper during manufacture.