

Service.



Self-Study Programme 265

Vehicle electrics in Polo Model Year 2002

For private or commercial purposes, in whole or in part, is not permitted unless authorised by Volkswagen AG. Volkswagen AG does not guarantee or accept any liability with respect to the correctness of information in this document.

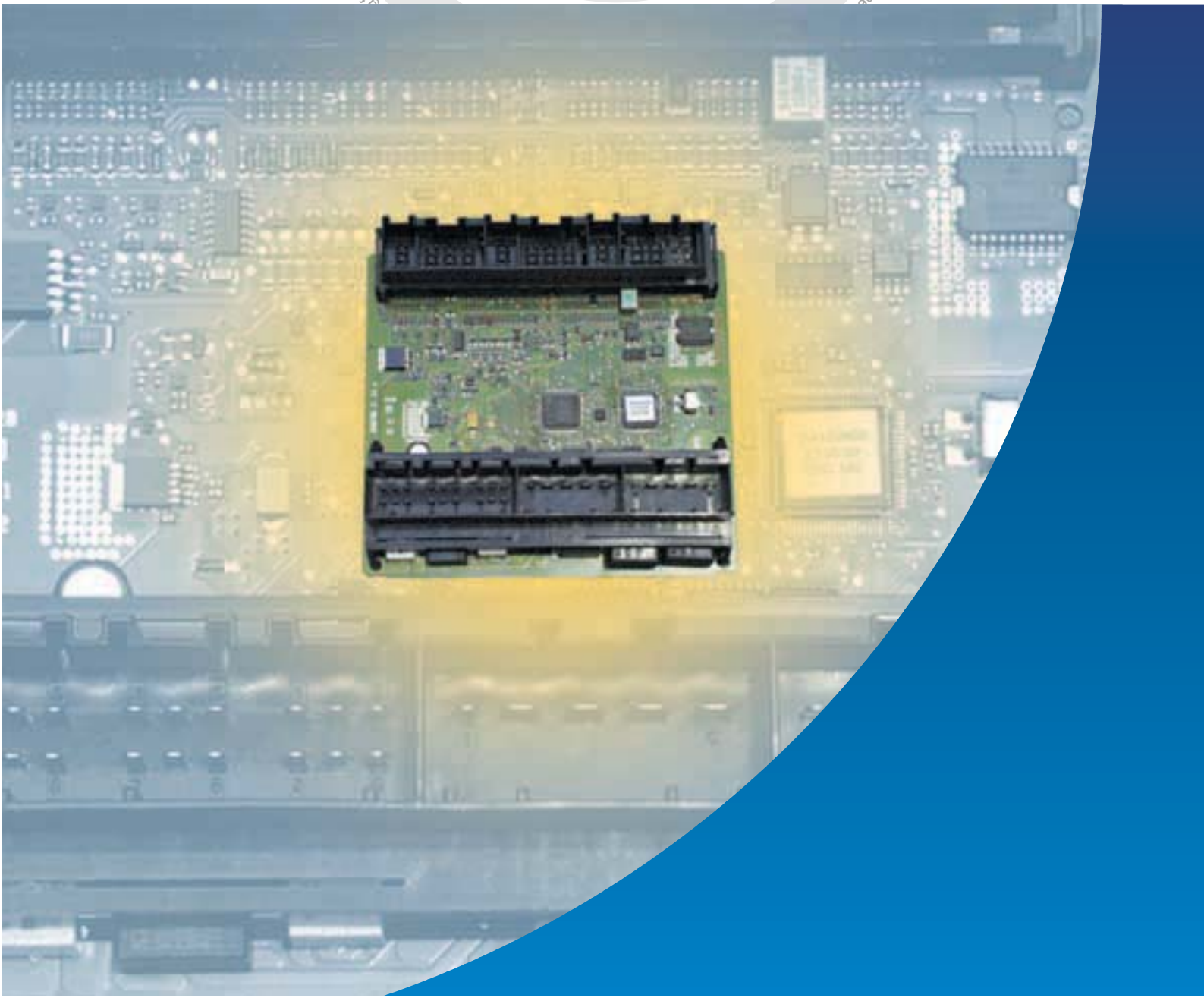

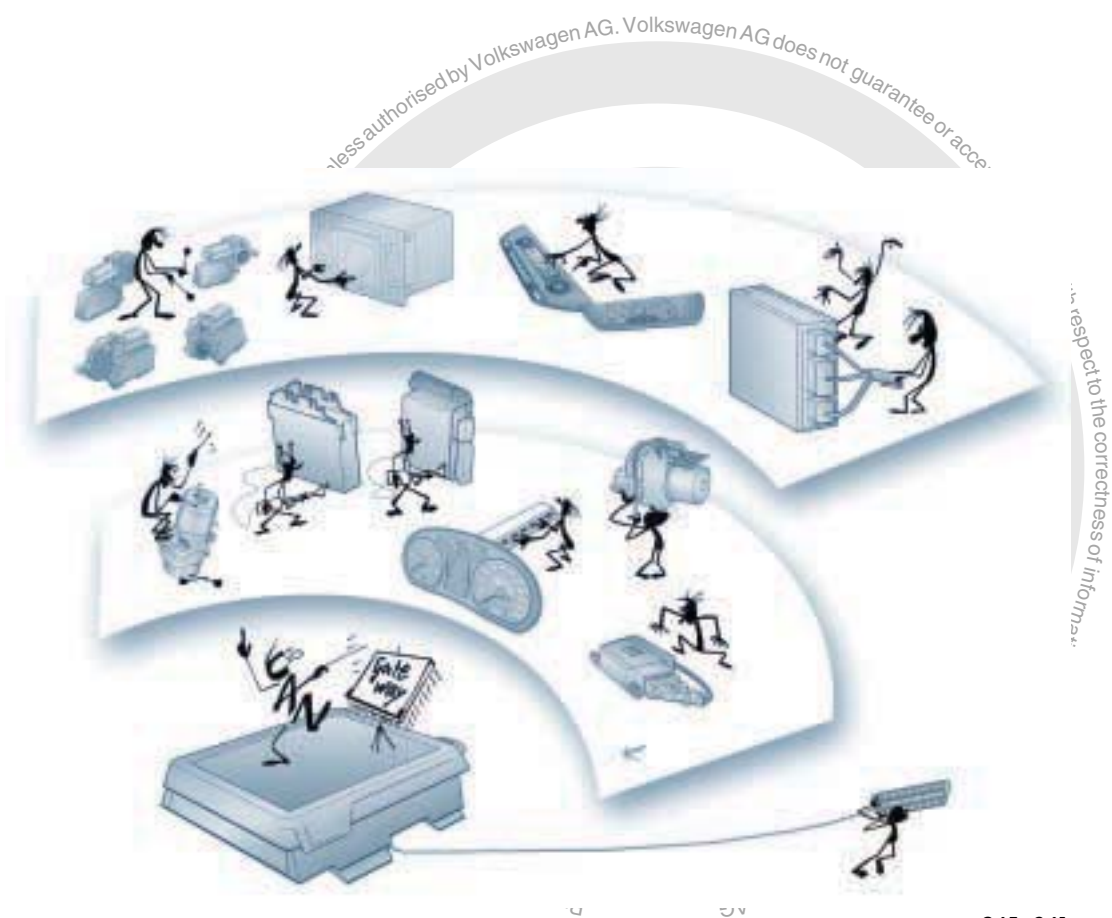

265_061

The range of electrical systems in new vehicles is expanding increasingly as a result of the ever more effective safety systems and enhanced convenience systems. The vehicle electrics in the Polo Model Year 2002 have been reorganised with the aim of retaining a clear arrangement within the comprehensive onboard power supply.

A major role in this connection is played by a onboard power supply control unit. It monitors the capacity utilisation of the onboard power supply and performs functions which, until now, were executed by separate relays and control units. Moreover, the databus diagnostic interface, which permits data transfer between different CAN databus systems, is also integrated in the onboard power supply control unit.

NEW



Important Note



The Self-Study Programme describes the design and function of new developments! The contents are not updated.

Please always refer to the relevant service literature for up-to-date inspection, adjustment and repair instructions.



Introduction	4
Onboard power supply	6
Onboard power supply control unit	13
Function diagram	22
CAN databus	24
Databus diagnostic interface	26
Special functions	30
Convenience and safety electronics	32
Sliding/tilting roof	37
Dash panel insert	38
Lighting	42
Self-diagnosis	44
Test your knowledge	46

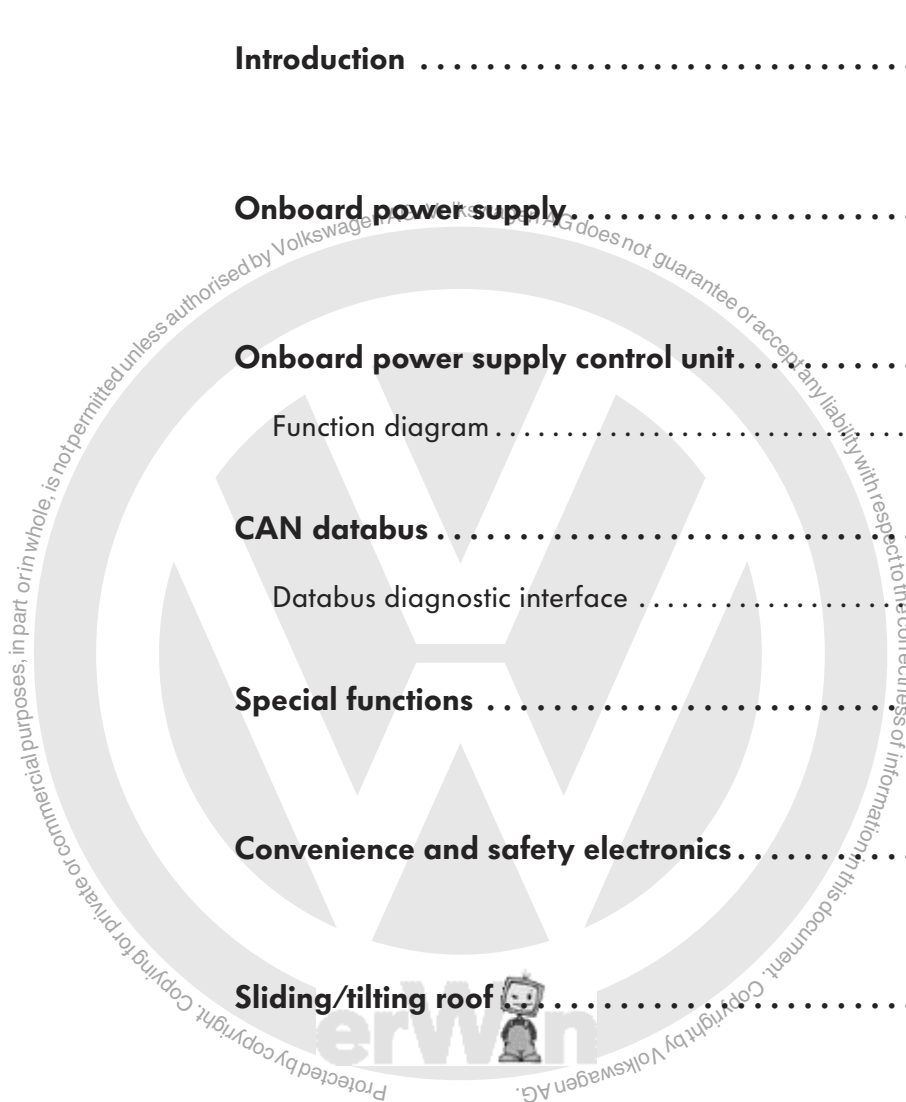

Introduction



The vehicle electrics of the Polo Model Year 2002 have been redesigned in terms of its concept and its structure.

The onboard power supply control unit plays a central role in this connection. It performs a wide range of new check, monitoring and relay functions.

The other control units are located decentralized within the vehicle.

In the pages which follow you will be able to familiarize yourself with the following subjects of the electrical system of the Polo Model Year 2002:

- Design of onboard power supply
- Tasks and functions of onboard power supply control unit
- Design of CAN databus system
- Tasks of databus diagnostic interface
- Presentation of convenience and safety electronics
- Design and functions of the dash panel insert
- Lighting concept

Overview of control units in the Polo

Radio or
Radio-navigation system

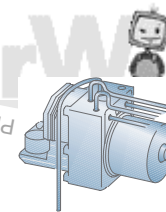
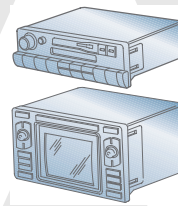

ABS control unit



Climatic/CLIMAtronic
control unit

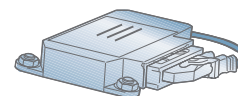

Airbag control unit

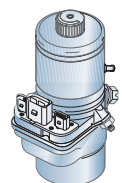

Power steering
control unit



Door control unit passenger side

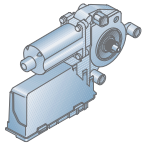

Sliding roof adjustment control unit

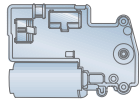

Rear right door control unit

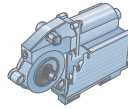

Control unit with display unit in dash panel insert

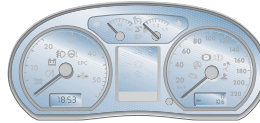

Rear left door control unit

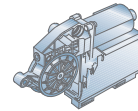

Door control unit driver side

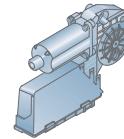

Onboard power supply control unit with gateway

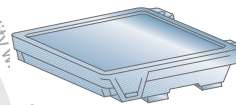

Engine control unit

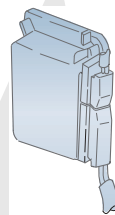

Automatic gearbox control unit

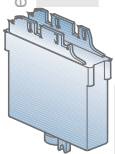

Convenience system central control unit

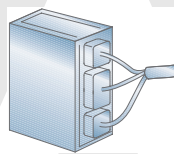

265_013

es. in part or in whole, is r

st availability w

spect to the correctness of information in this document. Copyright by Volkswagen AG.



Onboard power supply

Onboard power supply

The onboard power supply is a decentralized design. The most important stations are:

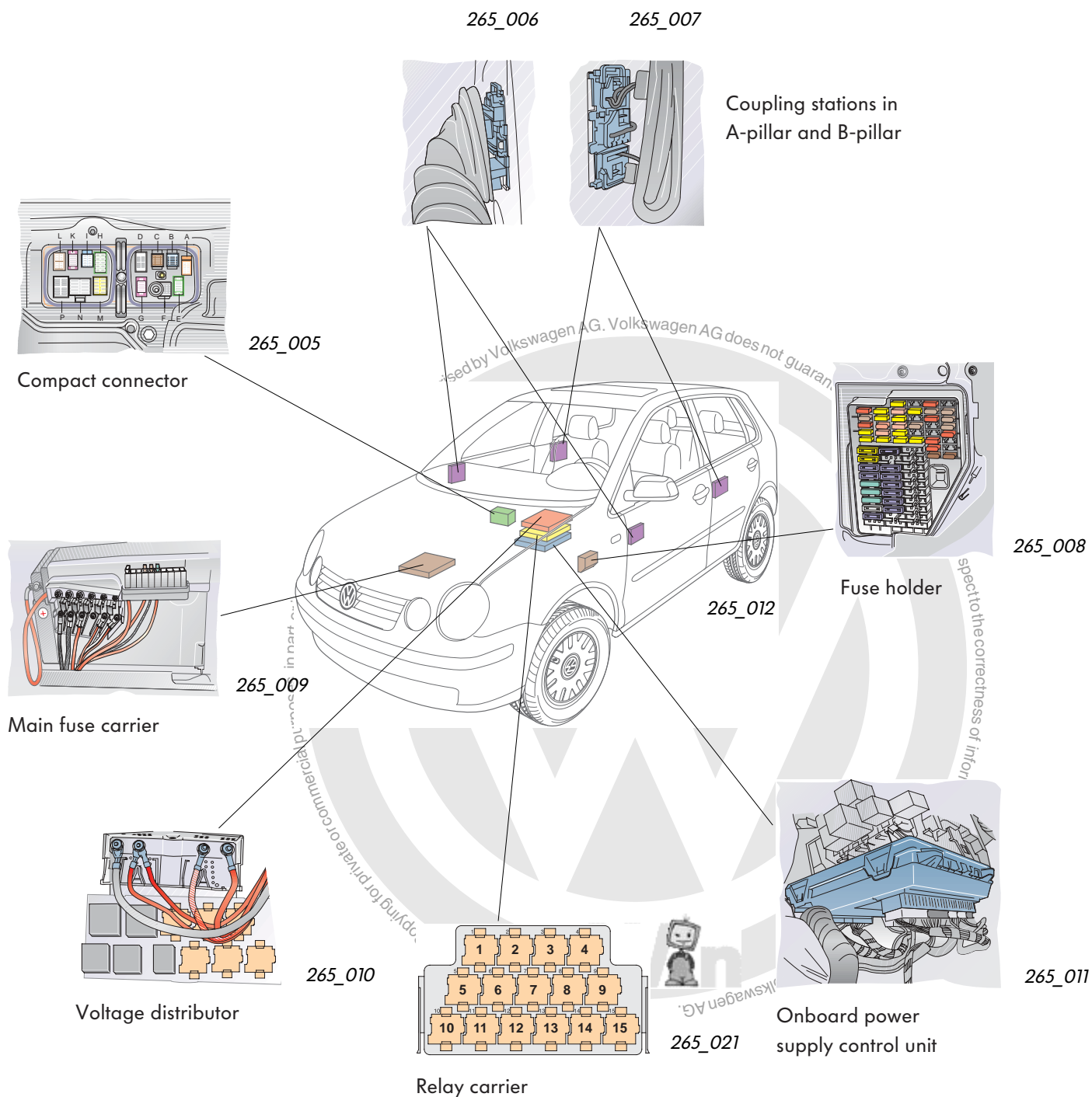

Main fuse carrier

The main fuse carrier is located on battery cover.

The number of fuses always depends on the equipment fitted to the particular model.

The main fuse carrier houses up to 6 strip fuses and 10 plug-in fuses.

A voltage cable provides the connection to the battery (positive). The fuses protect the individual power circuits immediately downstream of the battery from overloads.

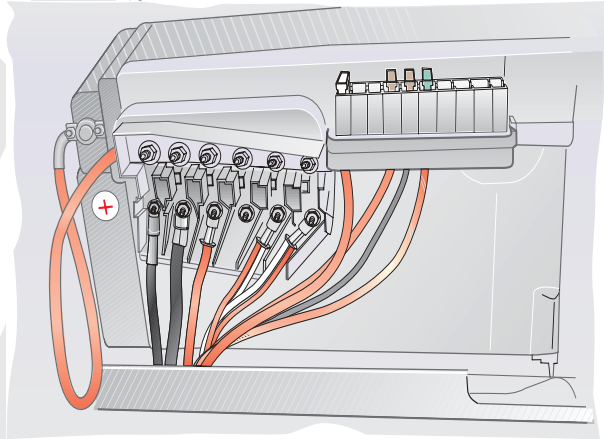

265_009

Voltage distributor

The voltage distributor is located on the driver side behind the dash panel cover.

The voltage distributor is responsible for distributing the current of terminal +30 from the main fuse carrier on the battery to the individual electrical components.

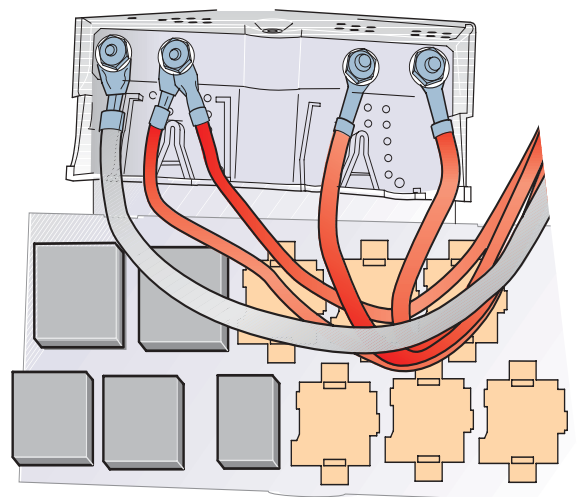

265_010

Onboard power supply

Fuse holder

The fuse holder is located behind the cover in the left side of the dash panel.

There are two types of fuses for protecting the power circuits:

- Mini-fuses up to 15 A
- Little fuses more than 15 A

This combination offers the following advantages:

- greater number of fuses within the same space
- greater number of individually protected circuits

These fuses are identified in the current flow diagram with the abbreviated designation „SB“.

Relay carrier

The relay carrier is located on the driver side behind the dash panel cover.

Compared to the design consisting of mini electrical centre and additional relay carrier, the relay carrier of the Polo is a single component with standardized design for accommodating the relays.

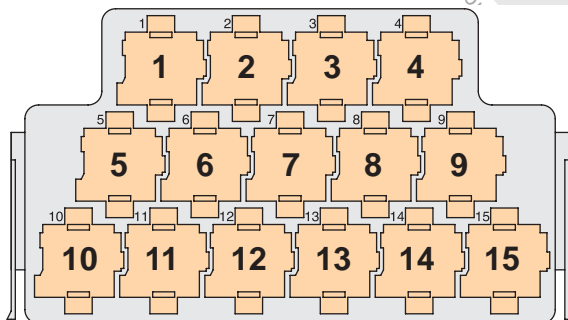

265_021

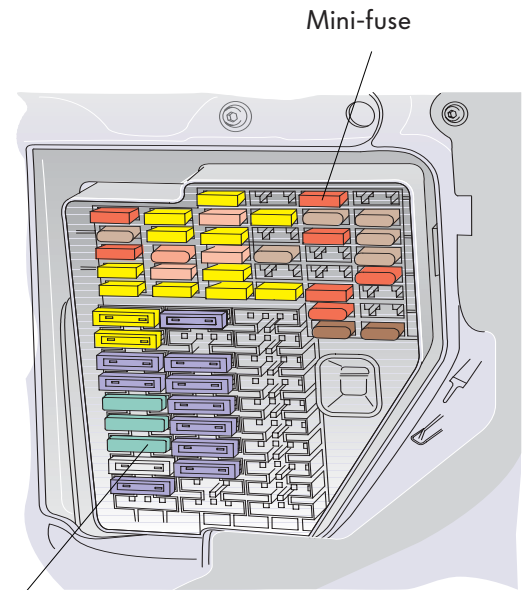

265_008

Position	Relay
1	Not assigned
2	Motronic power supply relay
3	Glow plug relay
4	Fuel pump relay (diesel engines)
5	Entry warning light relay
6	Headlight washer system relay
7	Starter lockout relay
8	Low heating capacity relay
9	High heating capacity relay
10	Simos control unit power supply relay
11	Relief relay for X ¹ contact
12	Fuel supply relay
13	Fuel pump relay (petrol engines)
14	Fuse carrier for electric auxiliary heater
15	Diesel direct injection system relay

Coupling stations

The purpose of the coupling stations is to link the electrical components in the doors to the rest of the onboard power supply.

The coupling stations permit:

- easy access
- separation of the wiring looms to the doors
- simplified fault finding

A-pillar coupling station:

It is located close to the top door hinge at the A-pillar.

This coupling station combines the plug connections to the following electrical components in the doors:

- loudspeaker
- exterior mirror
- lock unit
- warning light

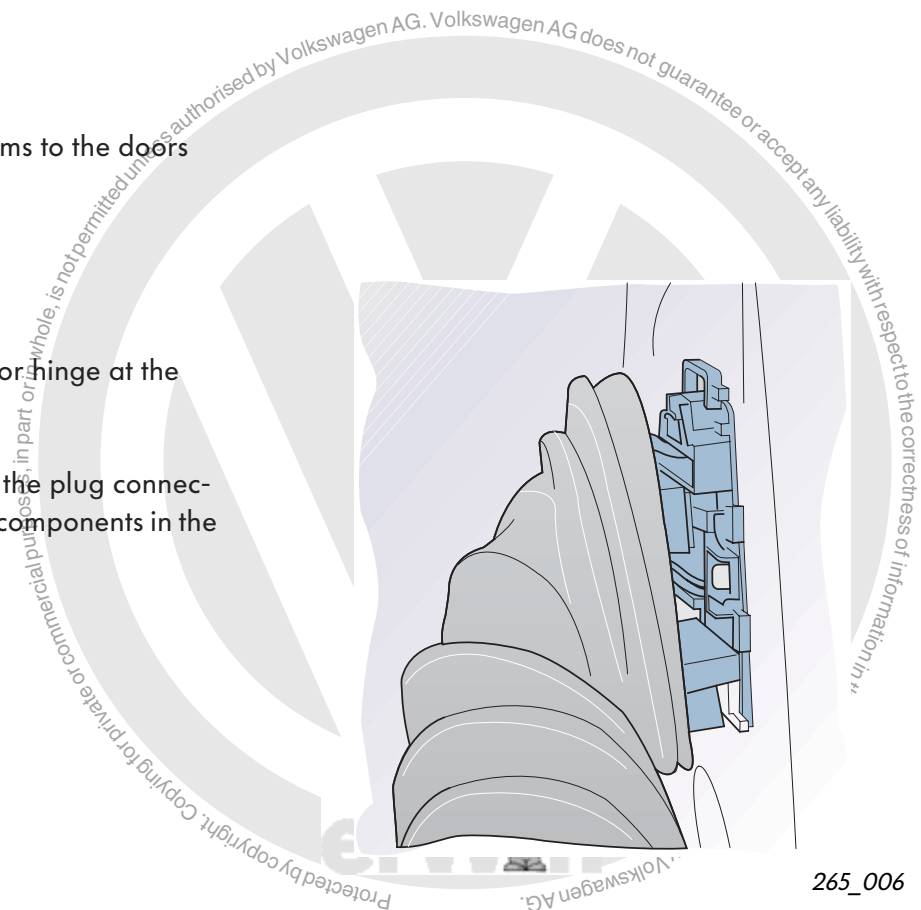

B-pillar coupling station:

It is located close to the top door hinge of the rear door at the B-pillar.

This coupling station combines the plug connections to the following electrical components in the doors:

- loudspeaker
- lock unit

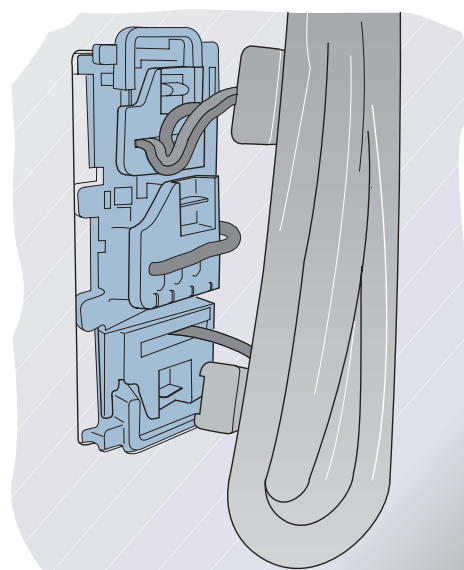

Onboard power supply

Compact connector

The compact connector links the part of the onboard power supply in the engine compartment to the part of the onboard power supply in the interior.

The onboard power supply is designed in such a way that all the cables of the components or the two wiring looms (engine compartment, interior) merge in their individual connectors of the modules on the relevant side of the compact connector.

The connection is created by means of the individual connectors of the modules, irrespective of the equipment or version variants.

The connector provides a straightforward means of separating the onboard power supply at this point. This greatly facilitates test operations as well as removal and installation work.

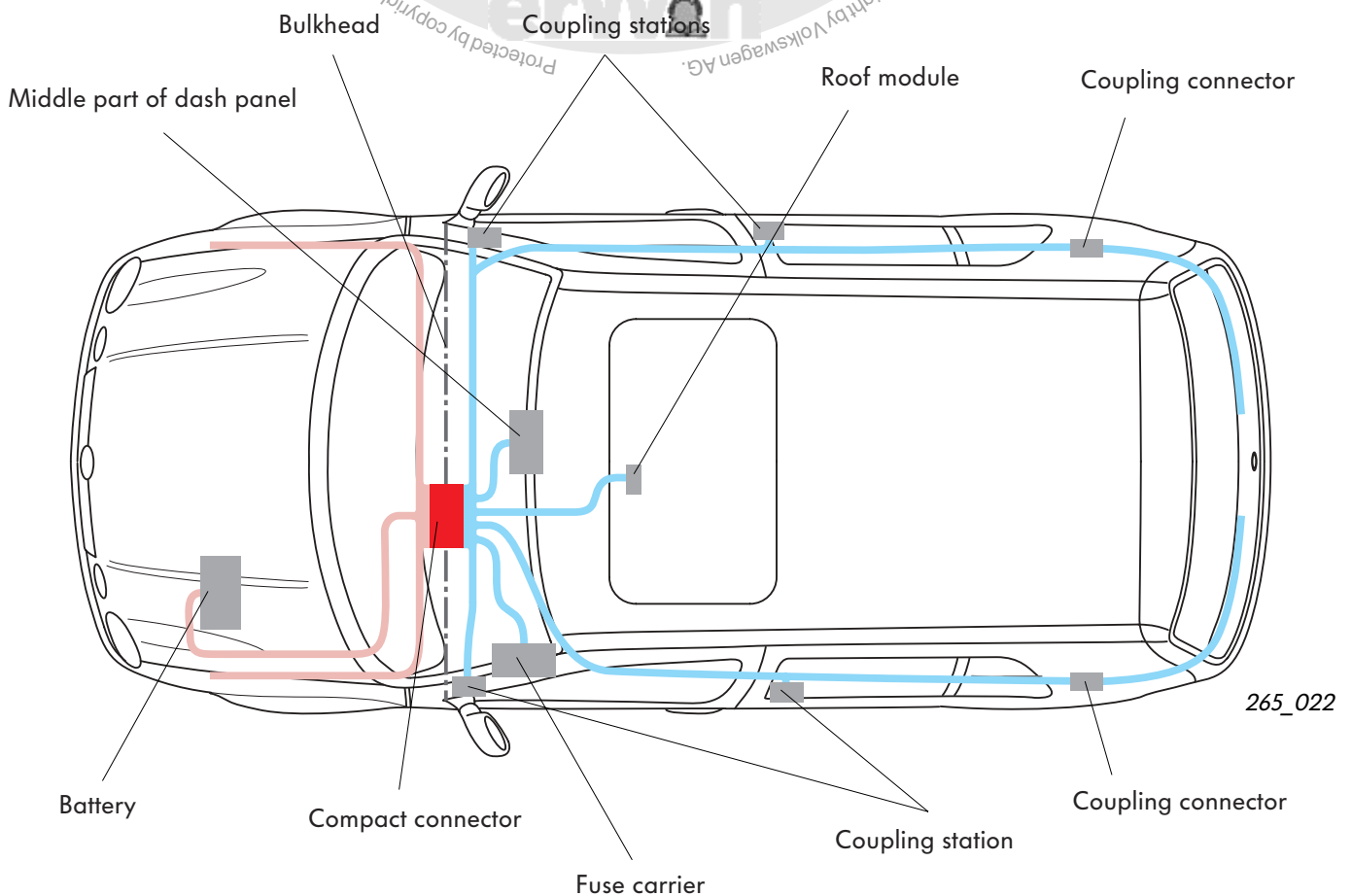

Design of the compact connector

The compact connector is located in the left of the bulkhead, behind the wiper linkage. It is accessible from the engine compartment as well as from the interior.



View from engine compartment

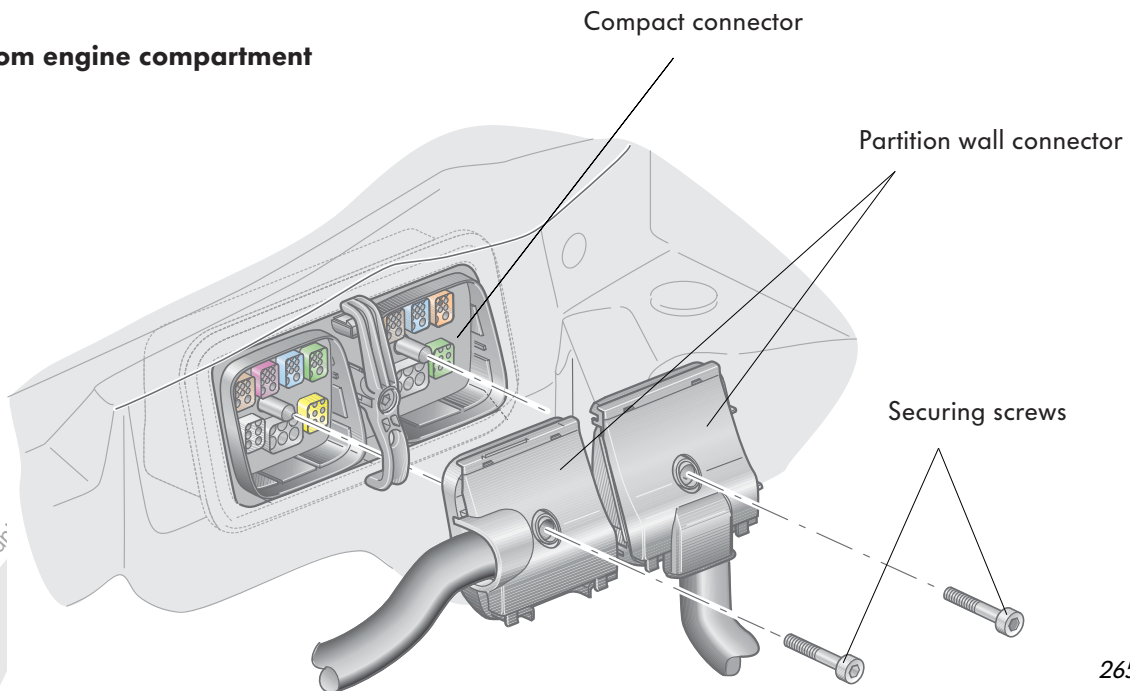

View from interior

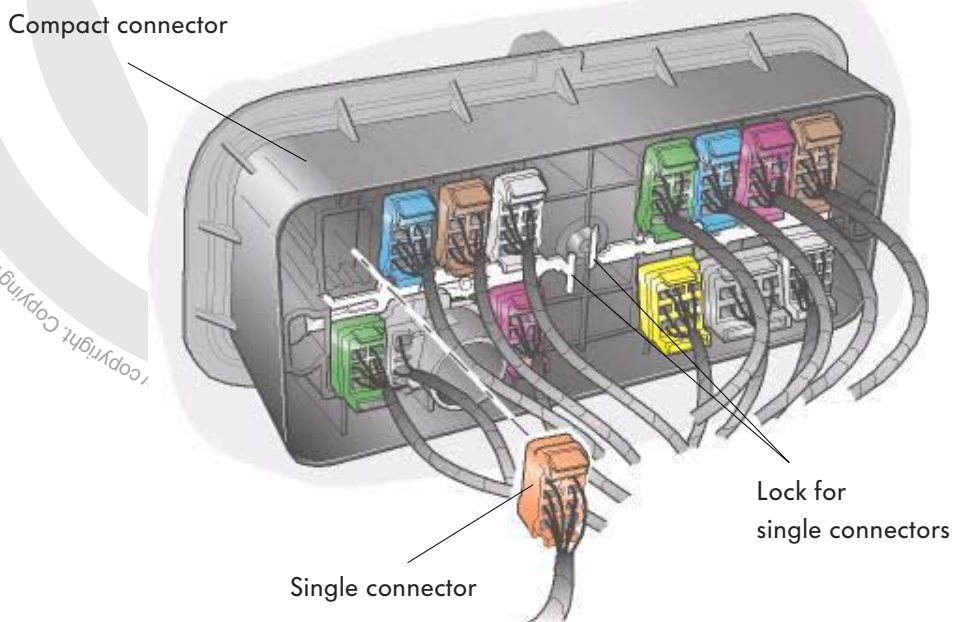

Copyright. Copying for private or commercial purposes, in part or in whole, is not permitted.

Onboard power supply

The compact connector is subdivided into various modules. The connections are created by means of mechanically coded connectors of different colours for the individual modules.



Compact connector
View from engine
compartment

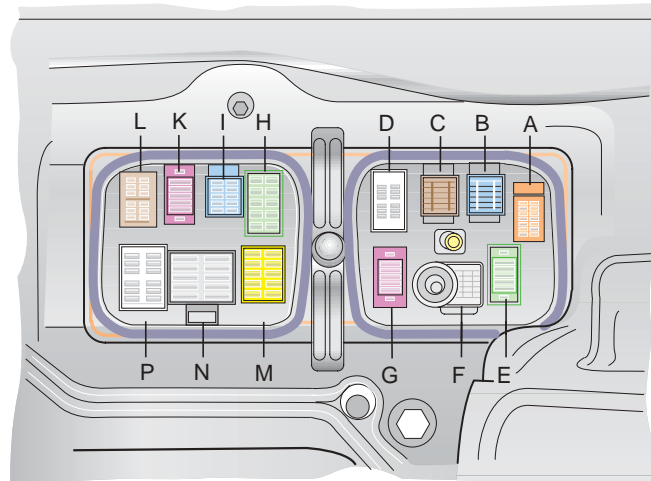

265_005

Connector assignment			
Module	Responsible for	Module	Responsible for
A	ABS, ESP	H	Not assigned
B	Gearbox, engine, K wire, clutch pedal switch	I	Additional heater, accelerator pedal position sender, brake pedal switch
C	Engine power supply	K	Engine, dash panel insert
D	Light, cruise control system, drivetrain CAN databus	L	AC, radiator fan control
E	Anti-theft alarm system	M	ABS, ESP
F	Battery +30	N	Diesel glow plug system
G	Dash panel insert	P	Windscreen wash and wipe system

Onboard power supply control unit

Onboard power supply control unit J519

Within the vehicle onboard power supply, the control unit plays a central role. It has functions which were previously performed by separate relays and control units.

The onboard power supply control unit performs the following functions:

- Load management
- Interior light control
- Fuel pump feed control
- Windscreen wash and wipe control, intermittent and rain sensor mode
- Exterior mirror and rear window heater
- Rear seat backrest monitoring
- Turn signal and hazard warning light control
- Horn control
- Cruise control system (supplying signals over drivetrain CAN databus)
- Remote release of boot lid/tailgate
- Instrument and switch lighting
- Maintaining operation of sliding roof and power windows

Additional functions on models fitted with automatic gearbox:

- Actuation of selector lever lock solenoid
- Starter lockout
- Actuation of reversing lights

Fitting location

The onboard power supply control unit is positioned on the driver side behind the dash panel cover.



Depending on the level of equipment, functions of differing extent are integrated in the control unit. Consequently, there are also variations in the positioning of the connector mounts.

Implementation of the onboard power supply control unit has made it possible to cut vehicle weight by reducing the extent of wiring and plug connections as well as a number of relays and control units.

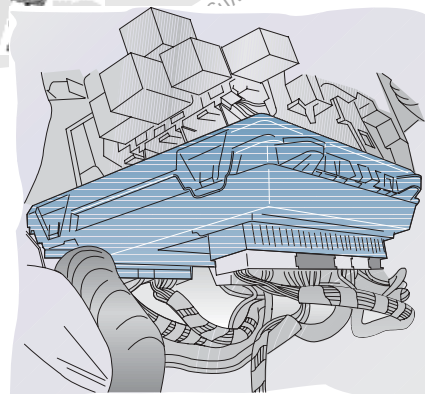

Onboard power supply control unit

Load management

The wide range of convenience functions and electrically heated components such as seat heater, rear window heater, exterior mirror heaters and electric auxiliary heater (heating element for auxiliary heater Z35) can result in an overload of the alternator when driving and thus in a drain on the battery.

This is particularly the case when driving extremely short distances and in winter as well as stop- and go journeys and vehicles with a high level of equipment.

The load management of the onboard power supply control unit regularly monitors the battery voltage, while taking into account the power demand of short-term consumers.

If it detects a voltage deficit in the onboard power supply, the control unit initiates measures to maintain vehicle operation and to ensure that the vehicle can be restarted.

Electrical circuit

- A Battery
- C Alternator
- J... Engine control unit
- J131 Heated driver seat control unit
- J132 Heated passenger seat control unit
- J255 CLIMATronic control unit
- J301 AC control unit
- J519 Onboard power supply control unit
- J533 Databus diagnostic interface
- Z1 Heated rear window
- Z4 Heated exterior mirror, driver side
- Z5 Heated exterior mirror, passenger side
- Z6 Heated driver seat
- Z7 Heated driver backrest
- Z8 Heated passenger seat
- Z9 Heated passenger backrest

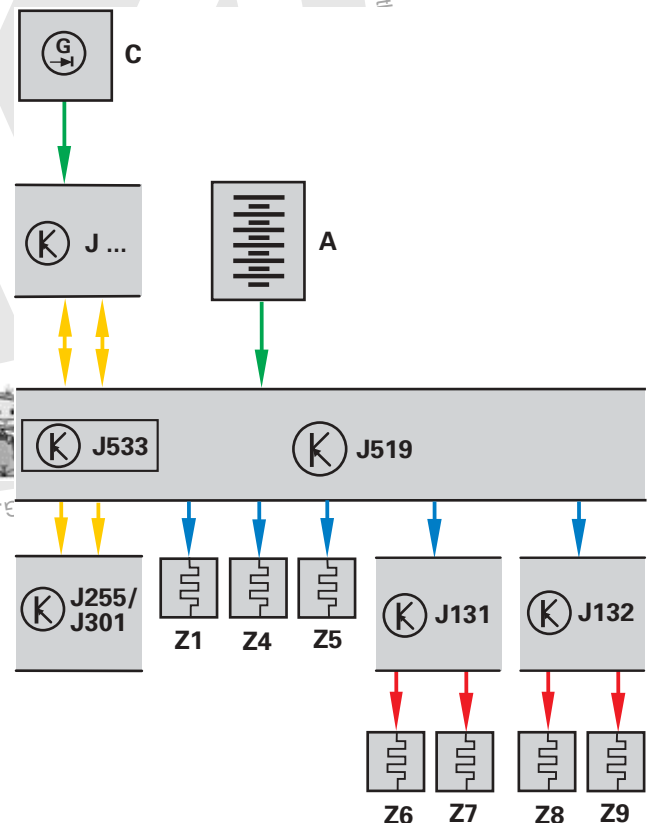

265_046

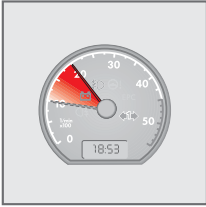
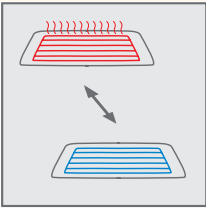
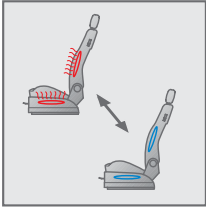
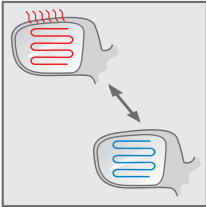
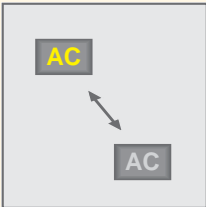

<p>Idling speed is increased if onboard power supply voltage drops below 12.7 V. If voltage drops below 12.2 V, onboard power supply control unit additionally switches off the following components:</p>		<p>If specified voltage is again reached, onboard power supply control unit takes the following measures:</p>
<p>1 ↓ Increases idling speed</p>		<p>Reduces idling speed ↑ 5</p>
<p>2 ↓ Switches off rear window heater</p>		<p>Switches on rear window heater ↑ 4</p>
<p>3 ↓ Switches off seat heaters</p>		<p>Switches on seat heaters ↑ 3</p>
<p>4 ↓ Switches off exterior mirror heaters</p>		<p>Switches on exterior mirror heaters ↑ 2</p>
<p>5 ↓ Reduces AC compressor capacity</p>		<p>Increases AC compressor capacity ↑ 1</p>

Onboard power supply control unit

Interior light control

If the switches of the front and rear interior lights are in the door contact position, the onboard power supply control unit J519 ensures that

- the interior lights are switched off after 10 minutes when the car is parked with the doors opened, to thus avoid any unnecessary drain on the battery.
- the interior lights are switched on for 30 seconds when the car is unlocked or the ignition key withdrawn. The interior lights are switched off immediately when the car is locked or the ignition is switched on.
- the interior lights are switched on in the event of a crash.

A further task of the interior light control is to switch off any lights which have been switched on manually (front and rear interior lights and reading lights, luggage compartment light, glove box light and vanity mirror lights) about 30 minutes after the ignition is switched off.

This function is likewise a protection for the battery capacity.

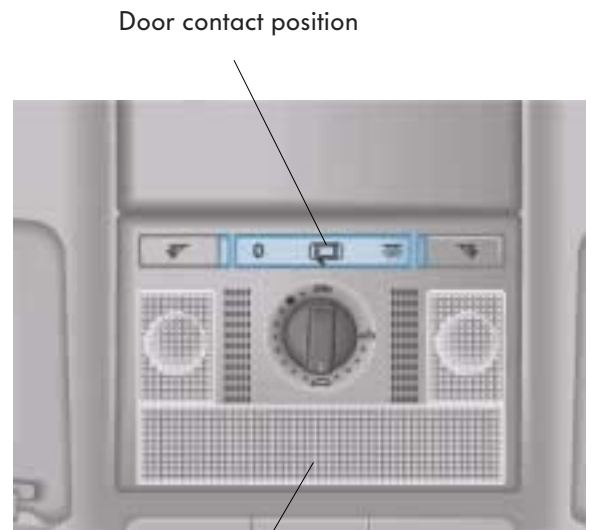

Front interior light

265_062

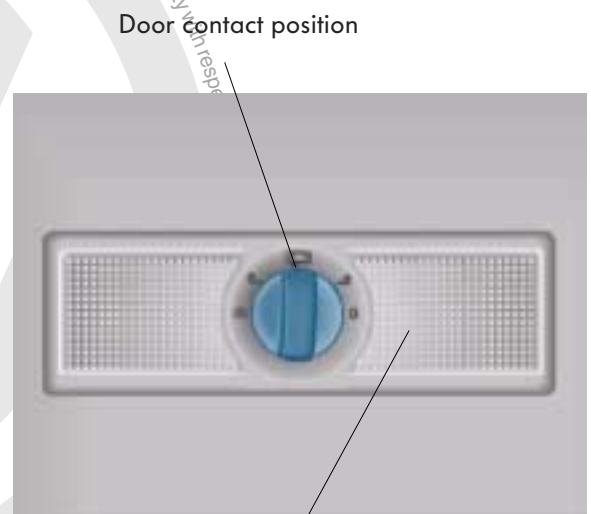

Rear interior light

265_063



If the switches of the interior lights are not in the door contact position, the interior lights are not switched on in the event of a crash.

for private or commercial purposes, in part or in whole, is not permitted.

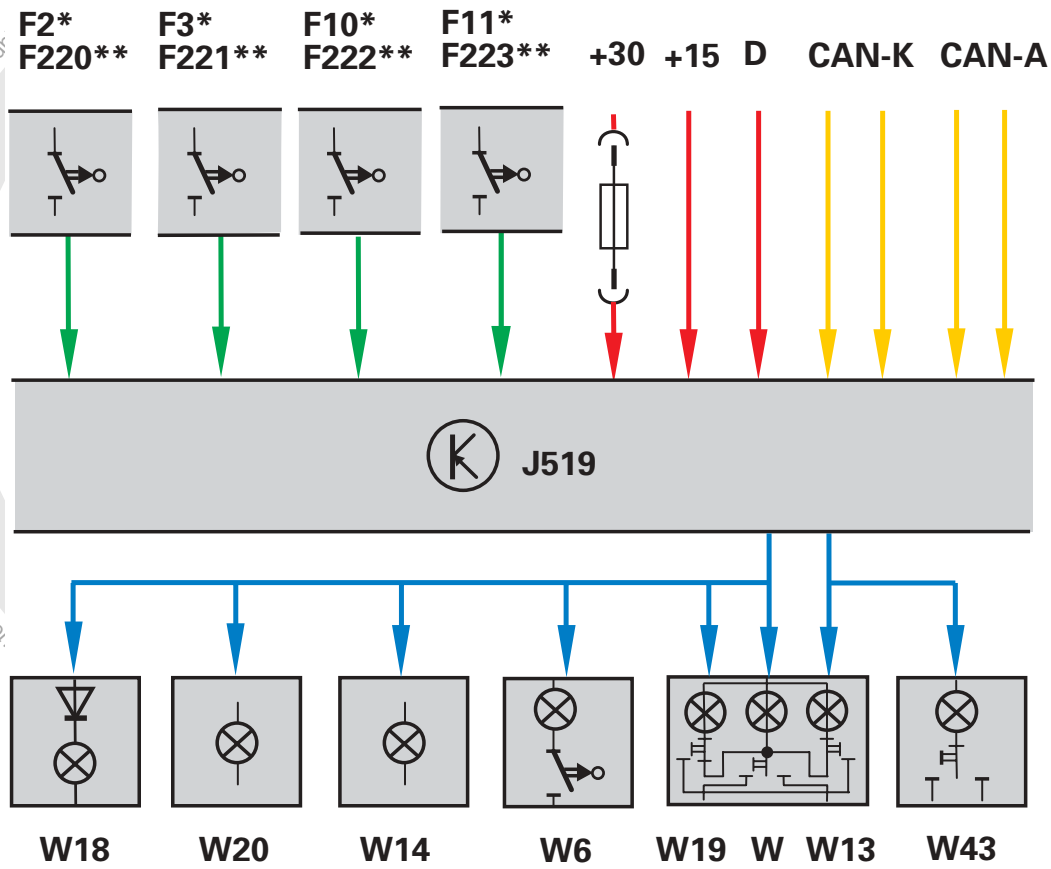

265_059

Electrical circuit

CAN-A	Drivetrain CAN databus	J519	Onboard power supply control unit
CAN-K	Convenience CAN databus	W	Front interior light
D	Ignition/start switch	W6	Glove box light
F2	Door contact switch, driver side	W13	Reading light passenger side
F3	Door contact switch, passenger side	W14	Illuminated vanity mirror (passenger side)
F10	Left rear door contact switch	W18	Left luggage compartment light
F11	Right rear door contact switch	W19	Reading light driver side
F220	Central locking lock unit, driver side	W20	Illuminated vanity mirror (driver side)
F221	Central locking lock unit, passenger side	W43	Rear interior light
F222	Central locking lock unit, rear left		
F223	Central locking lock unit, rear right		

* on models not fitted with central locking
 ** on models fitted with central locking

Onboard power supply control unit

Fuel pump supply control

The petrol engines in the Polo Model Year 2002 feature a new fuel pump supply control.

Two parallel relays - the fuel pump relay J17 and the fuel supply relay J643 - take the place of the individual fuel pump relays with integrated crash fuel shutoff.

Both relays are located on the relay carrier above the onboard power supply control unit J519.

Operating principle

When the driver door is opened, a signal is transmitted by the door contact switch F2 (or by the central locking lock unit F220) to the onboard power supply control unit. This in turn actuates the fuel supply relay J643 and the fuel pump G6 runs for about two seconds.

A time switch in the onboard power supply control unit prevents

- the fuel pump constantly running if the driver door is opened at short intervals.
- the fuel pump again being operated if the driver door remains open for more than 30 minutes.

When the ignition is switched on or the engine started, the fuel pump G6 is operated through the fuel pump relay J17 by the engine control unit.

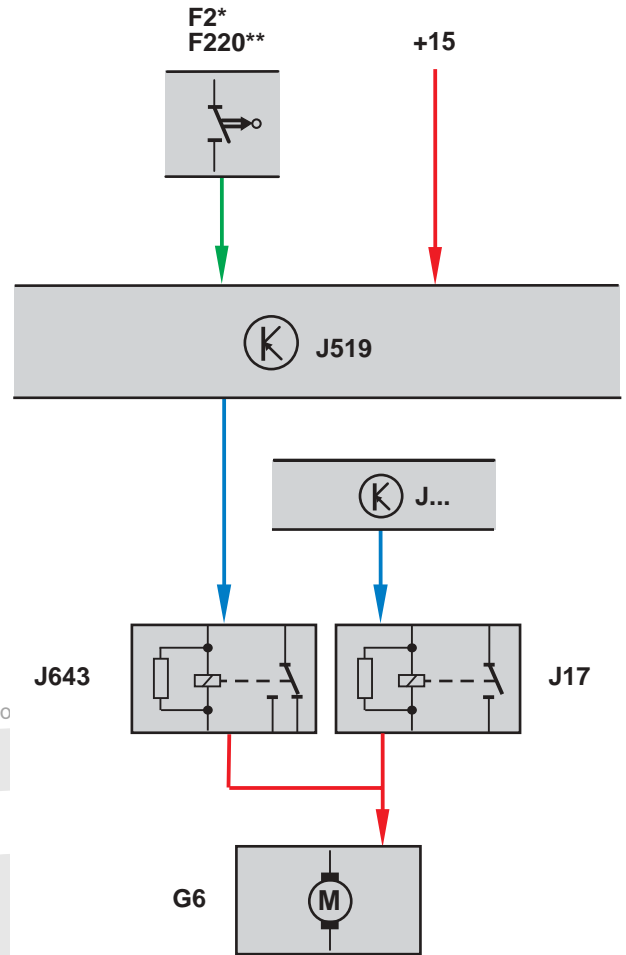

Electrical circuit

F2	Door contact switch driver side
F220	Central locking lock unit, driver side
G6	Fuel pump
J...	Engine control unit
J17	Fuel pump relay
J519	Onboard power supply control unit
J643	Fuel supply relay

* on models not fitted with central locking
 ** on models fitted with central locking

265_045

Activating rear screen wiper

When reverse gear is engaged, the rear screen wiper automatically makes a single sweep. The following conditions must be met for this purpose:

- windscreen wiper switched on with stage 1 or 2 or
- intermittent wipe (speed-responsive intermittent mode or rain sensor mode) switched on

Electrical circuit

- E22 Intermittent wiper switch
 F4 Reversing light switch
 J519 Onboard power supply control unit
 V Windscreen wiper motor
 V12 Rear screen wiper motor

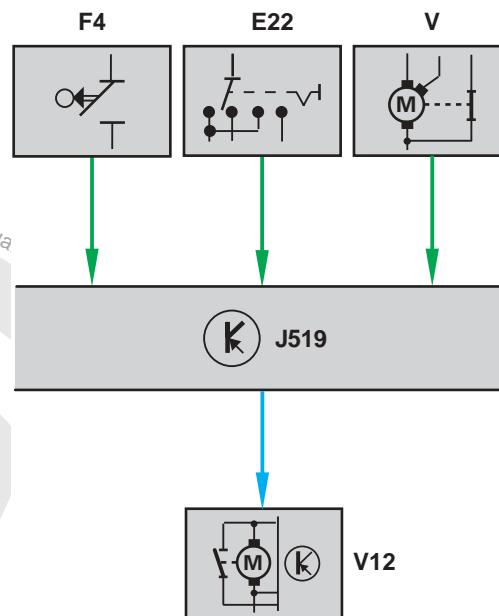

265_038

Blocking windscreen wipers

If the windscreen wipers are operating in the intermittent wipe mode (speed-responsive intermittent mode or rain sensor mode) and at the same time the bonnet is opened, a signal is transmitted by the bonnet contact switch F266 to the onboard power supply control unit.

The control unit blocks the movement of the windscreen wipers until the bonnet is again closed.

This function is intended as a safety measure when carrying out work on the car.

Electrical circuit

- E22 Intermittent wiper switch
 F266 Bonnet contact switch
 J519 Onboard power supply control unit
 V Windscreen wiper motor

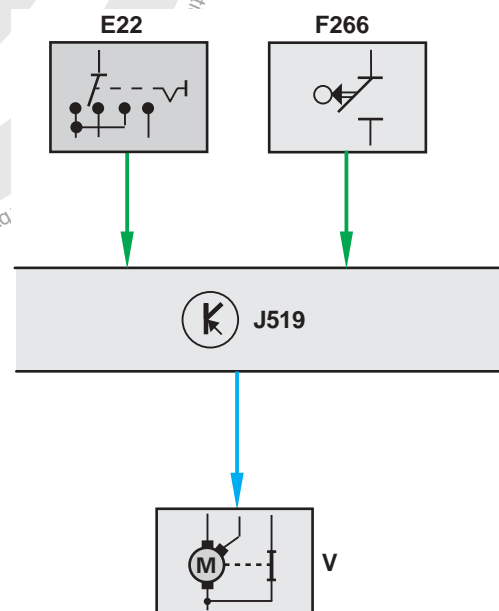

265_037



Onboard power supply control unit

Exterior mirror and rear window heaters

As a protection for the battery capacity, it is only possible to switch on the exterior mirror and the rear screen heaters when the engine is running. The heaters are switched off automatically again after about 20 minutes.

Electrical circuit

C	Alternator
E230	Heated rear window push button
E231	Exterior mirror heater push button
J519	Onboard power supply control unit
Z1	Heated rear window
Z4	Heated exterior mirror, driver side
Z5	Heated exterior mirror, passenger side

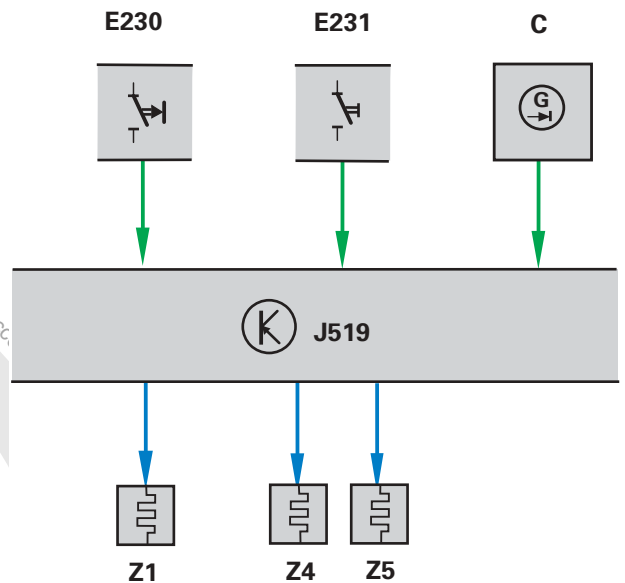

265_056

Monitoring rear seat backrest

Cars fitted with a three-point inertia reel seat belt for the middle seat of the rear seat bench feature a rear seat backrest monitoring function. If the backrest part for the middle seat of the rear seat bench is not correctly locked, a warning light in the dash panel insert comes on for about 20 seconds after the ignition is switched on.

Electrical circuit

CAN-K	Convenience CAN databus
F316	Right backrest contact switch
J285	Control unit with display unit in dash panel insert
J519	Onboard power supply control unit
K	Dash panel insert
K193	Backrest lock warning lamp, rear seat

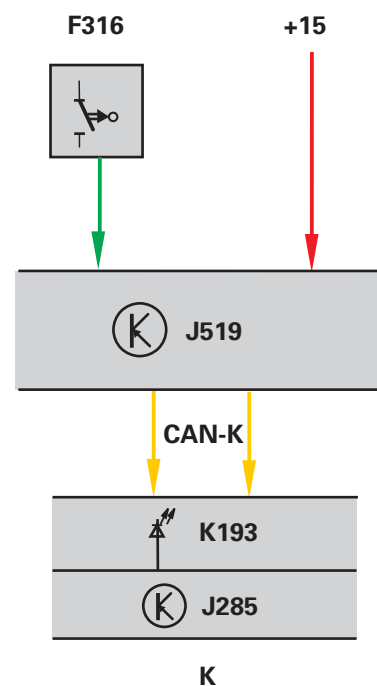

265_057

Turn signal and hazard warning light control

The following functions are performed by the onboard power supply control unit J519:

- Left, right turn signals
- Hazard warning lights (switched on manually or in the event of crash)
- Anti-theft alarm - flashing lights
- Central locking - flashing lights when car unlocked/locked
- Left, right trailer turn signal lights

Electrical circuit

CAN-A	Drivetrain CAN databus
CAN-K	Convenience CAN databus
E2	Turn signal light switch
E229	Warning light push button
J519	Onboard power supply control unit
M5	Bulb for left front turn signal light
M6	Bulb for left rear turn signal light
M7	Bulb for right front turn signal light
M8	Bulb for right rear turn signal light
M18	Bulb for left side turn signal light
M19	Bulb for right side turn signal light

Coding

The extent of the equipment and the national version of the vehicle determine the coding of the onboard power supply control unit.

This coding is factory-set.

If any modifications are made to the extent of the equipment in the service sector or when carrying out repairs, for example installing heated seats or attaching trailer coupling, or replacing control unit, it is then necessary to re-code the control unit.

This new code number should be entered using the „Guided fault finding“ mode with the Vehicle Diagnostic, Testing and Information System VAS 5051.

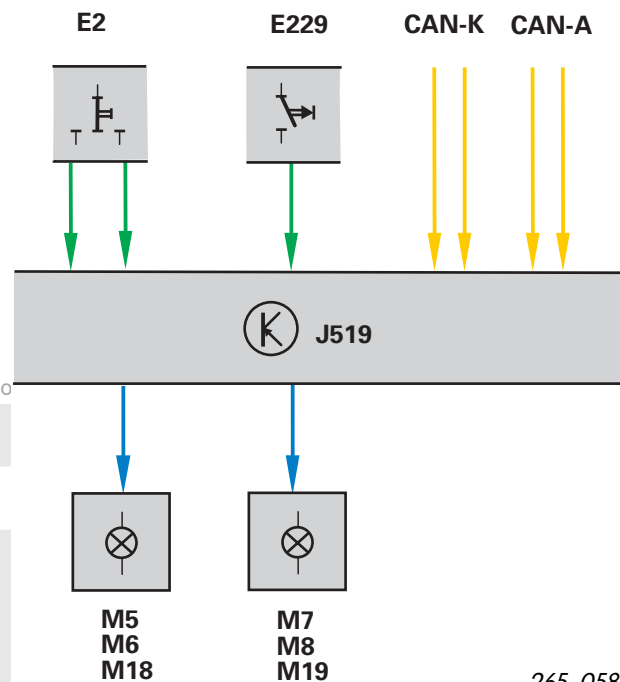

265_058

Equipment which has to be coded:

Fuel pump supply control
Rear window wiper with convenience setting
Remote release of boot lid/tailgate
Rain sensor
Headlight washer system
Heated exterior mirrors
Heated windscreen
Heated seats
4-door version
Interior light control
Electric load management active
Towing device



Onboard power supply control unit

Function diagram

Legend

A	Battery	J17	Fuel pump relay
B	Starter	J39	Headlight/washer system relay
C/L	Alternator/terminal L	J39	Headlight/washer system relay
CAN+/H	Driver/can CAN/High	J39	Headlight/washer system relay
CAN-/H	Driver/can CAN/High	J39	Headlight/washer system relay
CAN+/L	Convenience CAN/Low	J207	Wiper mirror relay
CAN-/L	Convenience CAN/Low	J207	Wiper mirror relay
D/50	Ignition/starter switch/terminal 50	J285	Control unit with display in dash panel inset
D/75	Ignition/starter switch/terminal 75	J393	Convenience system central control unit
D/86s	Ignition/starter switch/terminal 86s	J533	Onboard power supply control unit
E2/L/R	Turn signal signal	J643	Databus diagnostic interface
E22	Intermittent wiper switch	K10	Fuel supply relay
E34	Rear wiper switch	K142	Heated rear window warning lamp
E38	Intermittent wiper control	L44	Selector lever position P/N warning lamp
E45	CCS switch	L76	Seat heating switch light bulb
E94	Heated driver seat adjuster	L76	Seat heating switch light bulb
E95	Heated driver seat adjuster	M5	Selector lever display illumination
E227	CCS button (self)	M7	Front left turn signal light bulb
E230	Heating/rear window button	M8	Front left turn signal light bulb
E231	Exterior mirror heating button	M6	Front right turn signal light bulb
E234	Tailgate/boot lid handle release button	M6	Front right turn signal light bulb
F2	Door contact switch - driver side	M7	Rear right turn signal light bulb
F4	Door contact switch - front passenger side	M7	Rear right turn signal light bulb
F5	Rear left door contact switch	M8	Rear right turn signal light bulb
F10	Rear right door contact switch	M8	Rear right turn signal light bulb
F11	Contact switch in lock cylinder for tailgate/boot lid	M8	Rear right turn signal light bulb
F124	lock cylinder for tailgate/boot lid	M8	Rear right turn signal light bulb
F125/P-N	locking system	M8	Rear right turn signal light bulb
F17	Multifunction switch/terminal P-N	M8	Rear right turn signal light bulb
F18	Vanity mirror contact switch, driver side	M8	Rear right turn signal light bulb
F148	Vanity mirror contact switch, front passenger side	M8	Rear right turn signal light bulb
F218	Tailgate/boot lid central locking switch	M8	Rear right turn signal light bulb
F220	Central locking lock unit, driver side	M8	Rear right turn signal light bulb
F221	Central locking lock unit, front passenger side	M8	Rear right turn signal light bulb
F222	Central locking lock unit, rear left	M8	Rear right turn signal light bulb
F223	Central locking lock unit, rear right	M8	Rear right turn signal light bulb
F246	Right backrest contact switch	M8	Rear right turn signal light bulb
F36	Right backrest contact switch	M8	Rear right turn signal light bulb
G59	Driver seat temperature sensor	M8	Rear right turn signal light bulb
G60	Front passenger seat temperature sensor	M8	Rear right turn signal light bulb
G213	Rain sensor	M8	Rear right turn signal light bulb
H	Horn plate	M8	Rear right turn signal light bulb
H1	Horn	M8	Rear right turn signal light bulb
J...	Engine control unit	M8	Rear right turn signal light bulb

On models fitted with automatic gearbox
 On models fitted with automatic gearbox
 On models fitted with central locking
 On models not fitted with central locking



Legend:
 = Input signal (green line)
 = Output signal (blue line)
 = Positive (red line)



...or comment that the whole is not per...

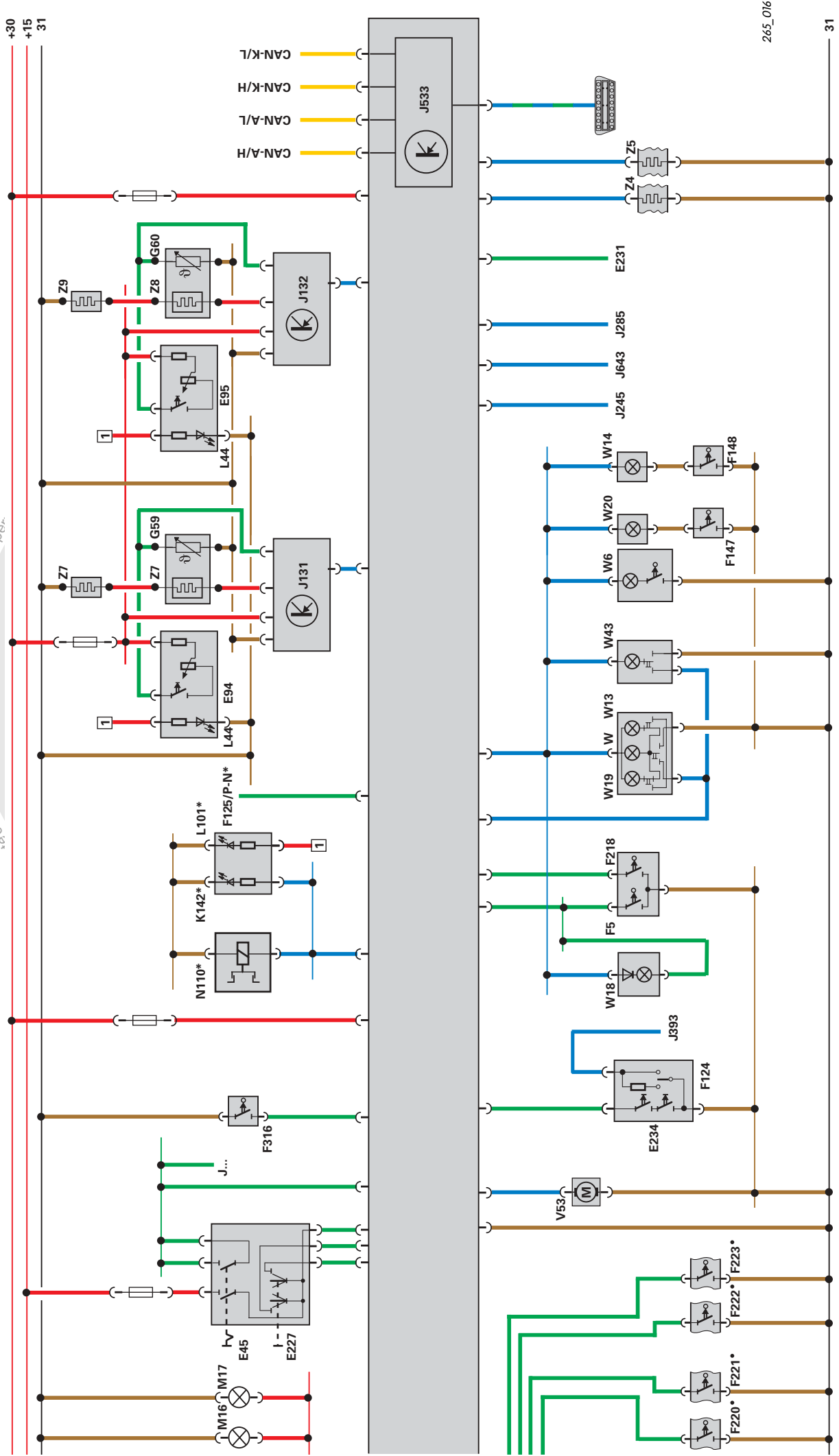

265_016

- = Earth
- = Bidirectional wire
- = CAN databus
- = Diagnosis connection

CAN databus

Drivetrain CAN databus

The Polo features a CAN databus system, consisting of the drivetrain CAN databus and the convenience CAN databus. They differ in terms of their transmission rate and their data content.

The drivetrain CAN databus operates with a transmission rate of 500 kBit/s in order to achieve rapid data transfer within the safety-relevant systems.



Onboard power supply control unit J519 with databus diagnostic interface J533 (gateway)

Steering angle sender G85



Control unit with display unit in dash panel insert J285



ABS control unit J104



Automatic gearbox control unit J217



Diagnostic connection

Engine control unit J...

Airbag control unit J234

Power steering control unit J500

265_023

Convenience CAN databus

The convenience CAN databus operates with a transmission rate of 100 kBit/s.

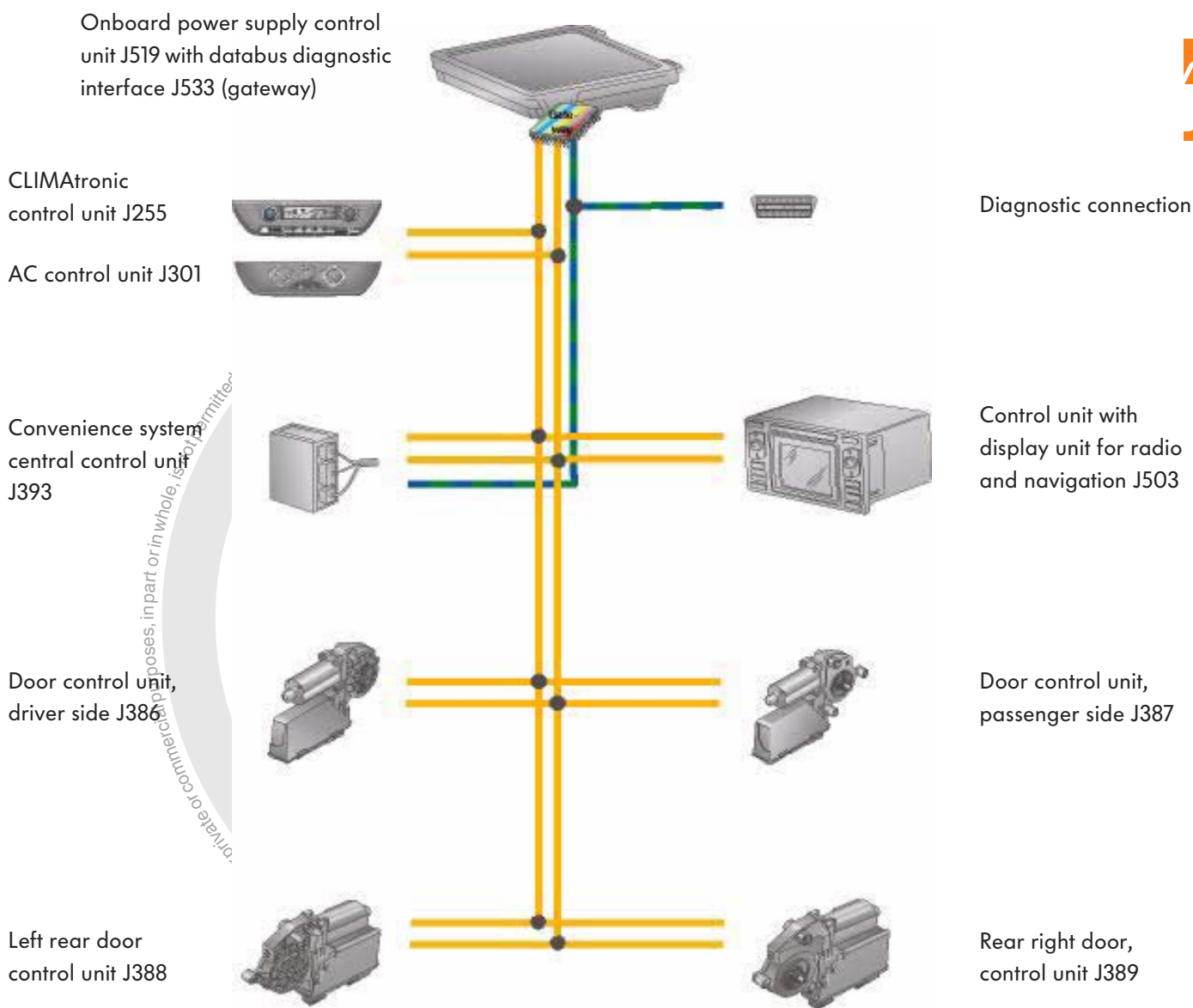

265_024

CAN databus

Databus diagnostic interface J533

The databus diagnostic interface J533 (gateway) is integrated in the onboard power supply control unit J519.

The databus diagnostic interface J533 performs 2 tasks:

1st task

It is responsible for the data transfer between the two CAN databus systems

- drivetrain CAN databus and
- convenience CAN databus.

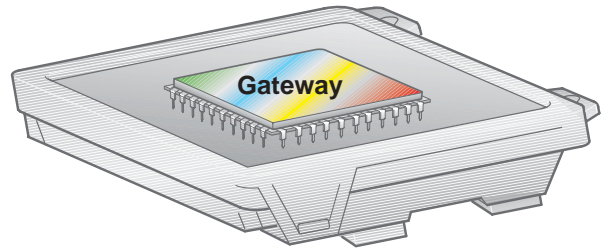

265_065

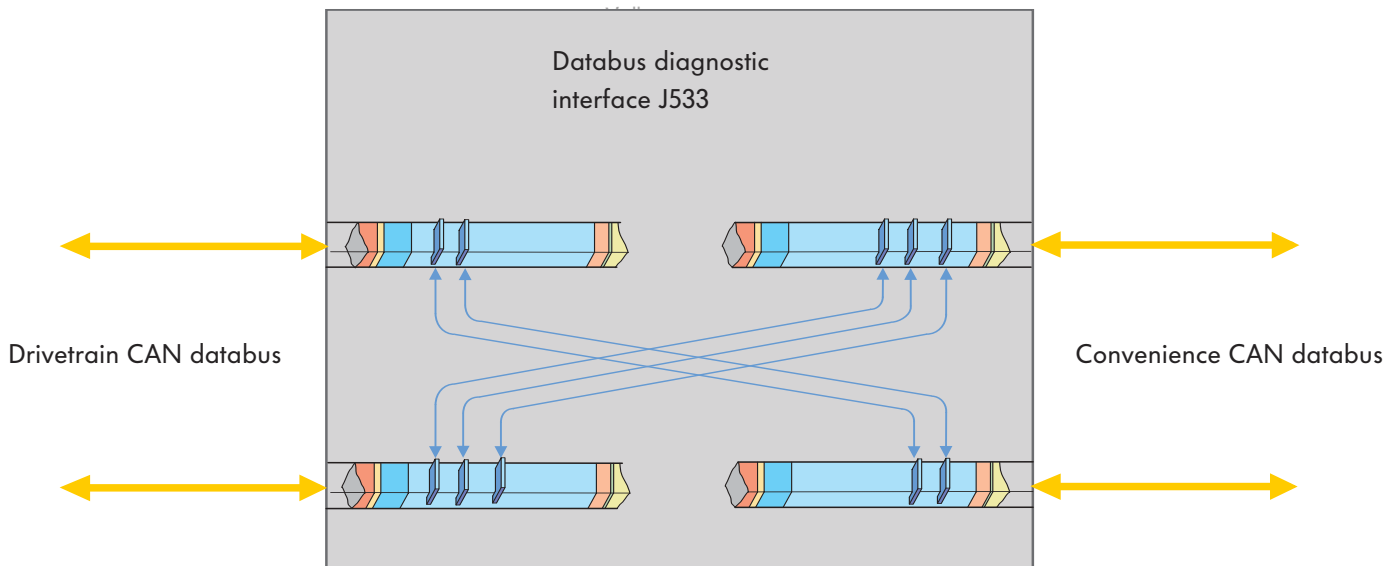

265_018

Direct communication between the systems is not possible because of the different transmission rates.

A link is required for exchanging information between the systems.

This link is achieved by means of the databus diagnostic interface J533.

The gateway receives the data arriving from a BUS system and relays the data to each other BUS system.

Example of data transfer between the CAN databus systems

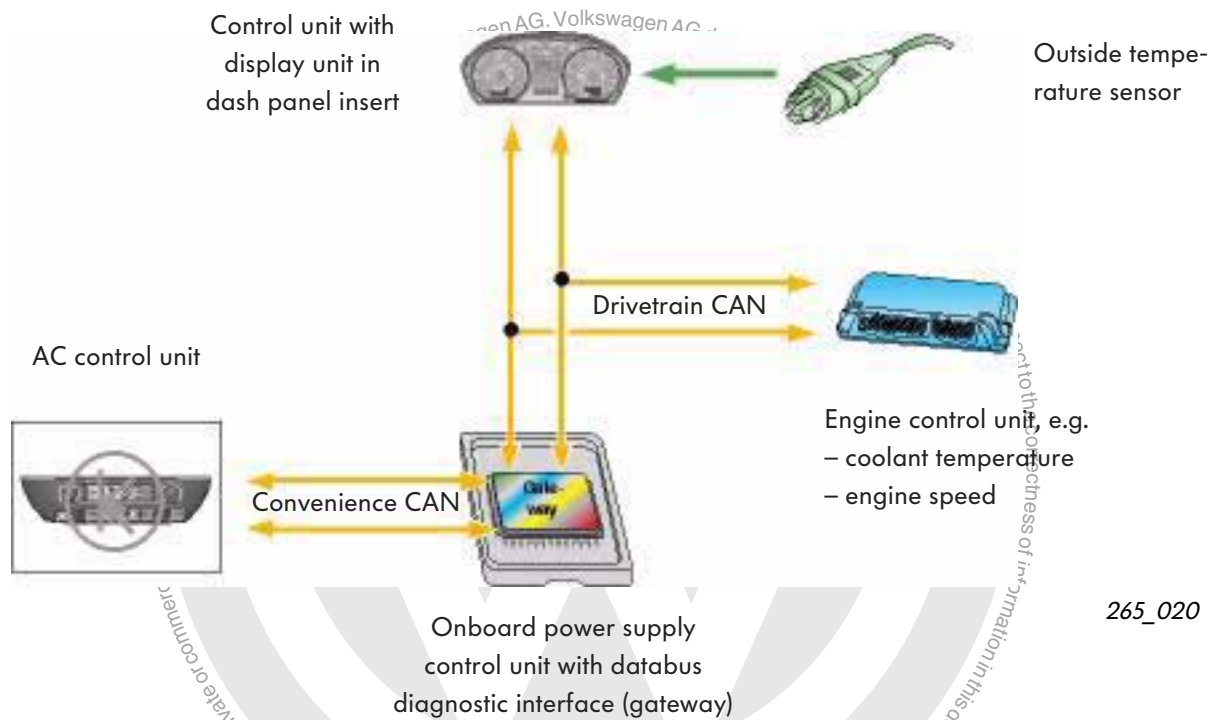

Multiple use of information of different systems over the CAN is a feature of modern vehicle electrics.

For example, data messages from the drivetrain CAN are used in the convenience CAN for controlling the automatic air conditioning (Climatic). The AC control unit is connected to the convenience CAN.

The following example shows the information flow from the drivetrain CAN to the convenience CAN.

- The outside temperature is detected by the temperature sensor in the bumper and relayed to the control unit with display unit in the dash panel insert. This is connected to the drivetrain CAN.

- Specific engine characteristic data, e.g. coolant temperature, engine speed, are detected by the engine control unit and made available to the drivetrain CAN.

The messages from the drivetrain CAN are relayed over the convenience CAN in the databus diagnostic interface (gateway).

The AC control unit is now in a position to read these messages and to use them for controlling the air conditioning system.



CAN databus

2nd task

The databus diagnostic interface J533 receives diagnostic data from the drivetrain CAN databus and from the convenience CAN databus and relays it over the K wire, and vice versa.

This makes it possible to use data from the Vehicle Diagnostic, Testing and Information System VAS 5051 for self-diagnosis.

The engine control unit, the automatic gearbox control unit and the convenience system central control unit have a separate K wire.

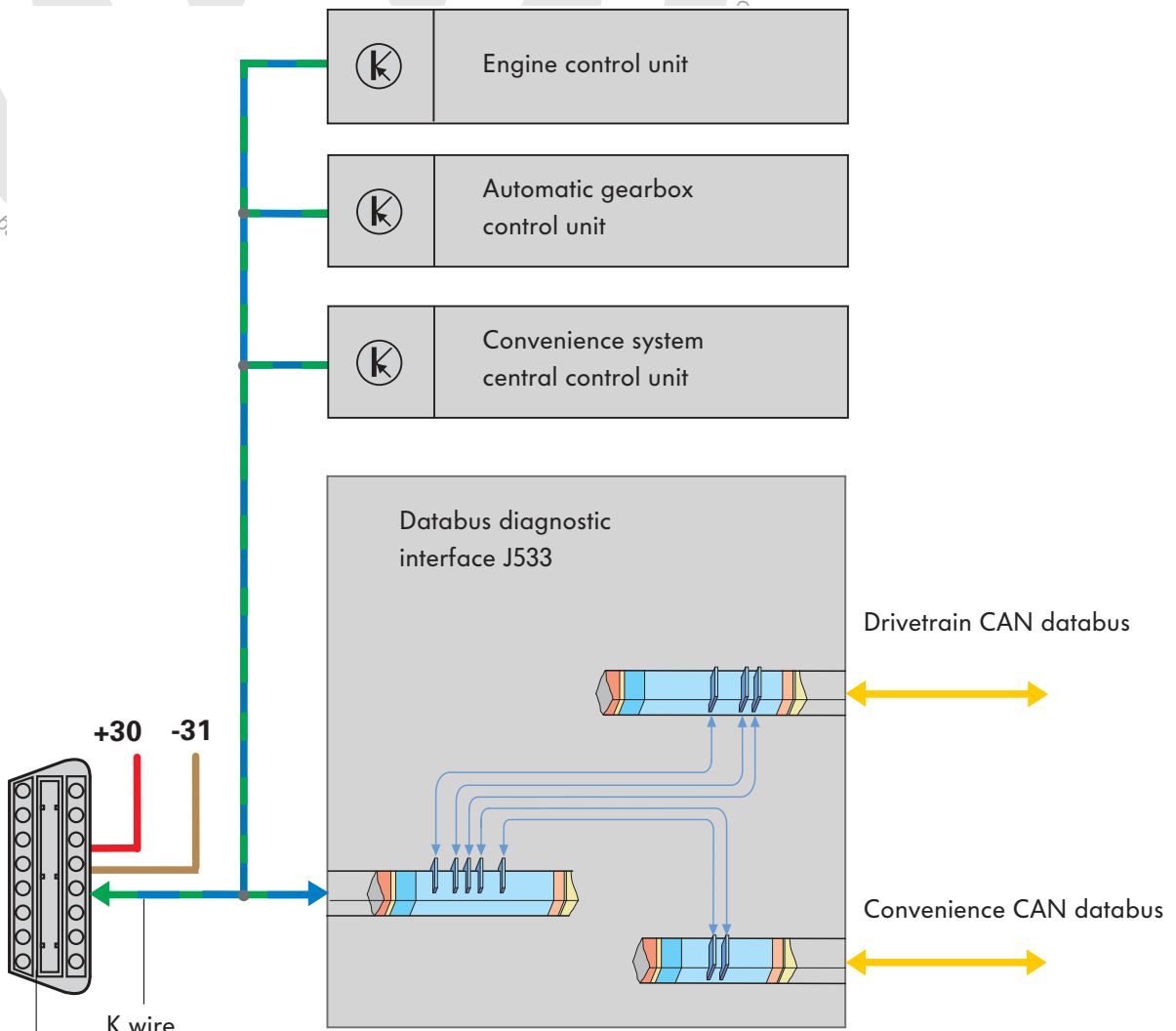

Diagnostic connection

265_019

Example for data exchange for diagnosis

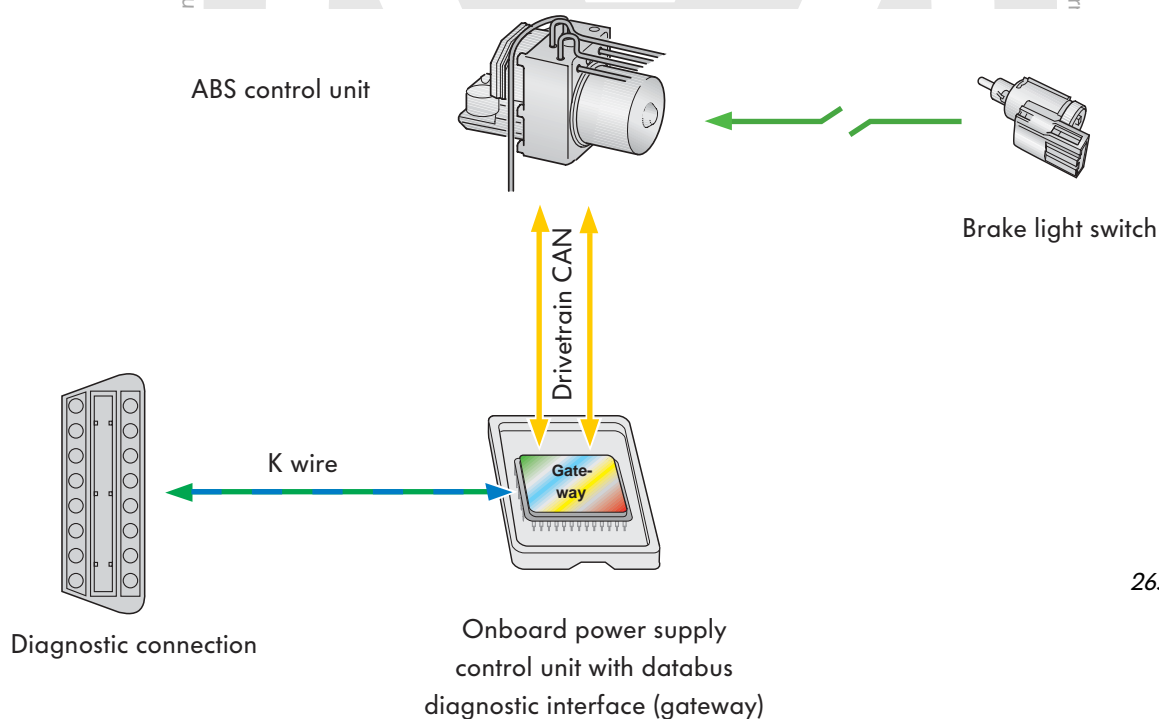

265_077

The following example shows the flow of information from the drivetrain CAN over the K wire.

- Because of a fault in the cable connection, the brake light switch does not supply any information to the ABS control unit.
- The ABS control unit is connected to the drivetrain CAN and thereupon sets a fault in its fault memory.

To enable the Vehicle Diagnostic, Testing and Information System VAS 5051 to process such diagnosis data, the databus diagnostic interface in the onboard power supply control unit relays the diagnostic information from the drivetrain CAN databus over the K wire. The data are not changed as a result of this; in other words, the information content transmitted over the K wire and the CAN databus is the same.

Special functions

Special functions in the event of a crash

The safety system of the Polo features automatic circuits which, in the event of a crash, contribute to minimizing the severity of an emergency situation.

The following actions are set in motion:

- central locking system is unlocked
- interior lights are switched on
- hazard warning lights system is switched on
- fuel supply is interrupted

Onboard power supply control unit with integrated databus diagnostic interface (gateway)

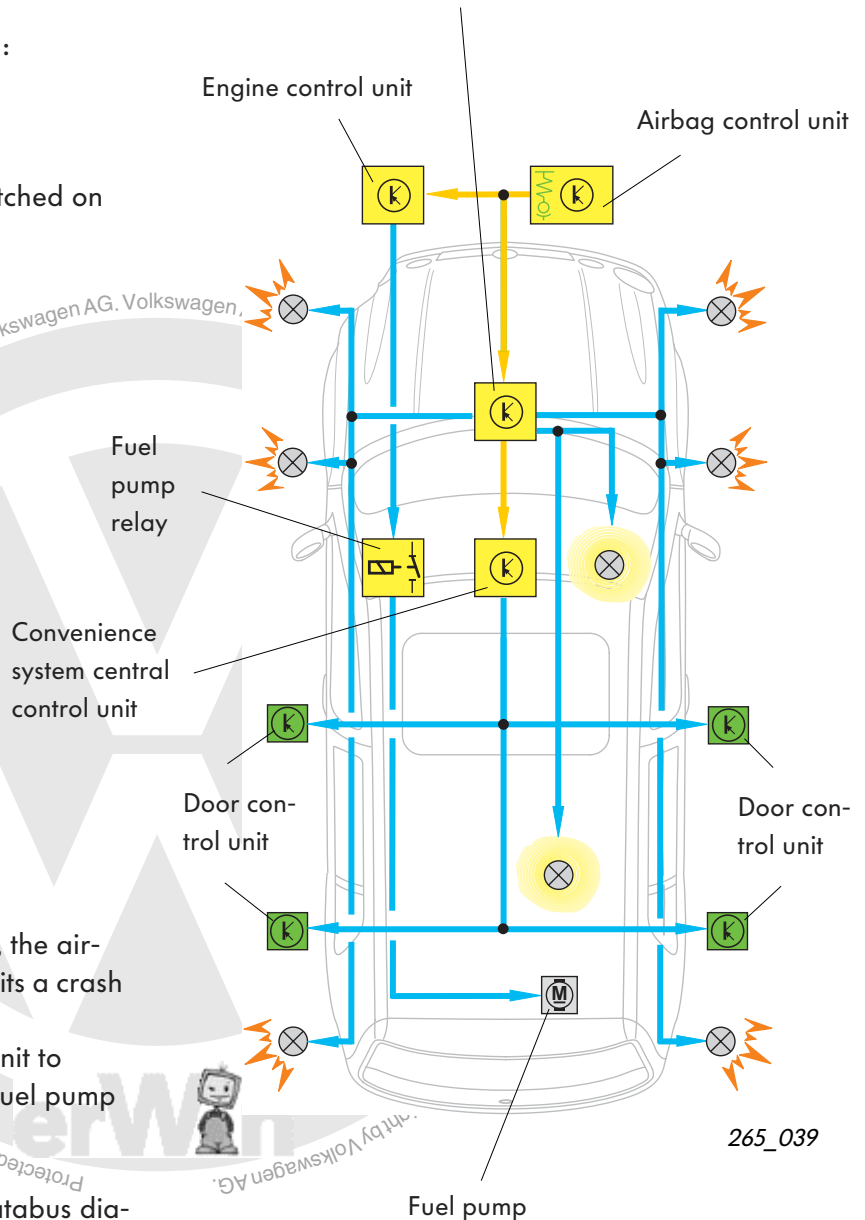

Operating principle

If the airbags are deployed in a crash, the airbag control unit simultaneously transmits a crash signal over the drivetrain CAN. This signal causes the engine control unit to switch off the fuel supply through the fuel pump relay.

The crash signal is relayed over the databus diagnostic interface (gateway) to the convenience CAN and the convenience system central control unit thereupon unlocks all the doors. In addition, the onboard power supply control unit switches on the interior lights (if the switches are in the door contact position) and also the hazard warning lights.



Energy saving functions

Sleep mode

To minimize current consumption when the ignition is switched off, the control units which are connected to the CAN databus are switched into a sleep mode.

In the case of the drivetrain CAN databus, this is the normal situation after the ignition is switched off as data only require to be transmitted in the drivetrain CAN databus if the ignition is on. In the case of the convenience CAN databus, the sleep mode is activated after the ignition is switched off and provided the following conditions exist:

- hazard warning light system off
- function retention elapsed
- no transfer of diagnostic data
- exterior lights off

Wake-up mode

In the event that the control unit detects a wake-up command resulting from one of the actions listed below, it relays this to the other control units so that these control units are also activated.

In the case of the drivetrain CAN databus, the wake-up command is always relayed after the ignition is switched on.

In the case of the convenience CAN databus, the wake-up command is transmitted after the following actions:

- ignition switched on
- hazard warning light system active
- change in status of doors, tailgate, bonnet and ignition lock
- exterior lights on



Exception:

The control unit with display unit in the dash panel insert, which is connected to the drivetrain CAN databus, also requires data from the convenience CAN databus even when no supply voltage is present (ignition off). For this reason, either a direct convenience CAN connection or a cable connection (wake-up cable) to the onboard power supply control unit is required. This depends on the equipment version of the dash panel insert.

Electrical circuit

- J285 Control unit with display unit in dash panel insert
- J519 Onboard power supply control unit
- J533 Databus diagnostic interface

= CAN databus

= Wake-up cable

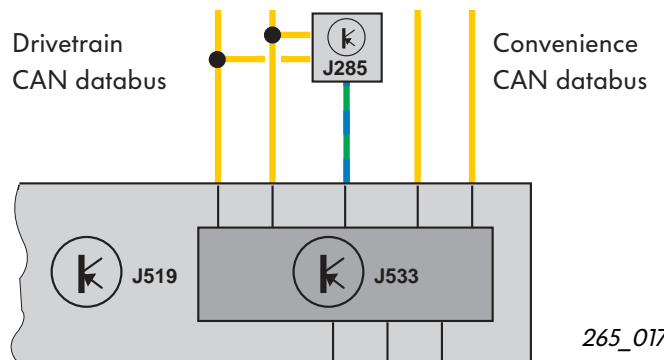

265_017

Convenience and safety electronics

The convenience system

is a decentralized design.
It consists of a central control unit and at least 2 door control units.



You can obtain further information on the interactions of the convenience system in Self-Study Programme 193. Only supplementary details are presented here.

Functions of the central control unit

- Central locking of rear lock
- Convenience closing functions (power windows, sliding roof)
- Single door opening of driver door
- Central locking of doors
- Unlocking and locking of complete vehicle with interior push button (Lock-Unlock)
- Anti-theft alarm system which can be deactivated only with remote control
- Ultrasound interior monitoring with deactivate function
- Self-diagnosis
- Actuation of central locking warning lamp -SAFE-

Functions of the door control units

- Electrically adjustable exterior mirrors with fold-in function
- Power windows with excess force limiter and with gentle opening/closing to minimize noise

**Overview of convenience system
(schematic diagram)**

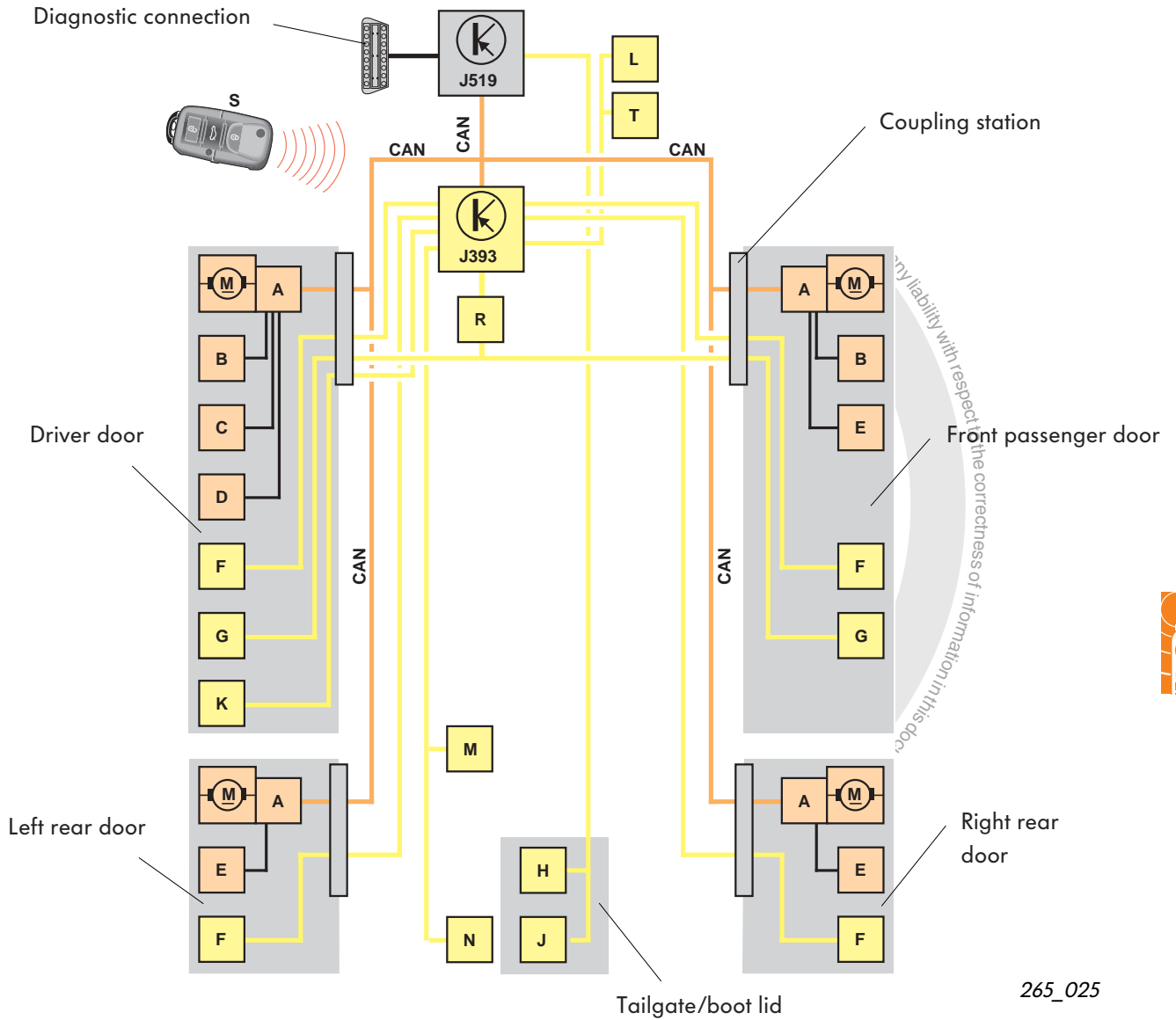

265_025

- | | | | |
|------|--|---|--------------------------------------|
| J393 | Convenience system central control unit | J | Tailgate push button |
| J519 | Onboard power supply control unit | K | Central locking warning lamp -SAFE- |
| A | Door control unit | L | Interior monitor sensor unit |
| B | Electrically adjustable rear-view mirror | M | Interior monitor push button |
| C | Mirror and heater adjustment switch | N | Alarm horn |
| D | Driver door operating panel | R | Relay for warning lights, doors |
| E | Power window switch | S | Remote control |
| F | Central locking door lock | T | Sliding roof adjustment control unit |
| G | Entry warning lamp | | |
| H | Tailgate/boot lid rotary tumbler switch | | |

Convenience and safety electronics

Remote control

Remote release of tailgate/boot lid

Models fitted with a remote control feature an additional push button for separate remote release of the tailgate/boot lid.

If the remote release push button is pressed, only the tailgate/boot lid is unlocked. If the tailgate/boot lid is not opened within two minutes, it is automatically relocked.

This function is coded in the onboard power supply control unit (refer also to Onboard power supply control unit page 21).



Remote release button for tailgate/boot lid

265_052

Single door opening of driver door

This function is intended for personal safety. If the remote control Unlock button is pressed briefly only once, only the driver door is unlocked. This is indicated by all the turn signal lights flashing briefly.

If the Unlock button is pressed a second time, all the locks of the car are unlocked.

If the car has been completely unlocked and no door or boot lid/tailgate is opened within 30 seconds, the car is locked again. This prevents the car being left unlocked unintentionally for a lengthy period.

This option is coded in the convenience system central control unit in the delivery state of the vehicle in conformity with the vehicle equipment.



Unlock button

265_066

Anti-theft alarm with interior monitoring

The anti-theft alarm

monitors the following areas

- doors,
- bonnet,
- boot lid/tailgate and
- ignition

for unauthorized opening or operation.

Interior monitoring

operates as an ultrasound monitoring system and is used only in combination with the anti-theft alarm.

This system additionally monitors the interior of the car for any unauthorized attempt to enter the car.

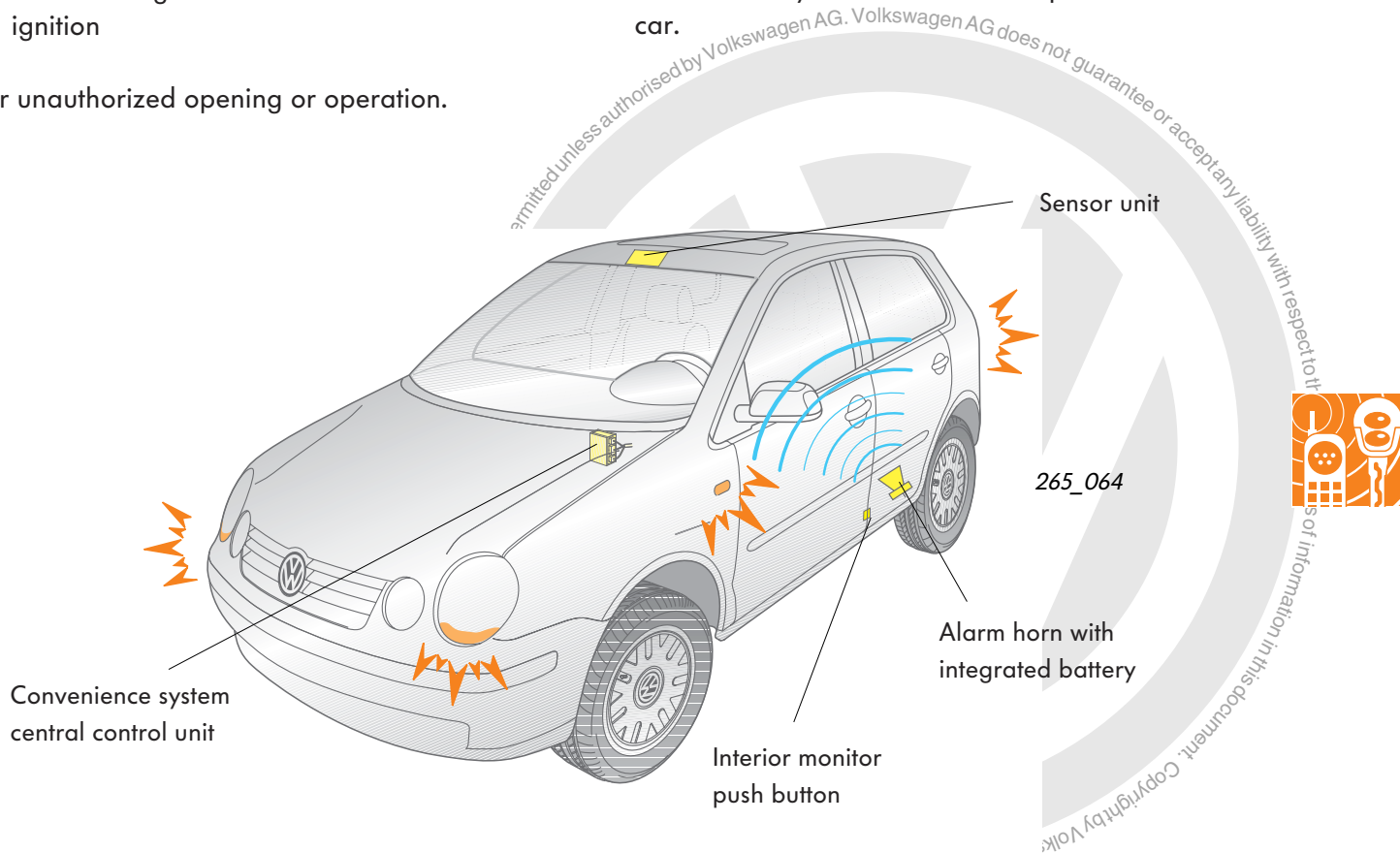

An audible alarm is provided by the alarm horn of the anti-theft system and a visual alarm by the turn signal lights.

The system is safe against false alarm resulting from:

- knocking on the car roof or against the windows,
- movements of air caused by wind or vehicles passing, temperature changes such as interior of car heating up as a result of extreme sunlight penetration and
- noises of any type (e.g. horns, sirens and bells).

Convenience and safety electronics

Operating principle of interior monitor

The interior monitor is switched on automatically at the same time as the anti-theft alarm system is activated. The anti-theft alarm is activated and deactivated with the remote control after the car has been locked and unlocked.

The sensor unit consists of a transmitter module, a receiver module and the analysis electronics. The monitoring unit is positioned behind the front interior light in the headlining.

In the armed state, the transmitter module transmits ultrasound waves and receives their echo a short time later with the aid of the receiver module.

These ultrasound waves are not perceptible to the human ear.

The analysis electronics detect any irregularities in this ultrasound field and triggers the alarm through the convenience system central control unit.

The push button for the interior monitor is located in the bottom half of the left B-pillar. If the button is pressed (button lights up yellow) and the car is locked, the interior monitor is deactivated.

The interior monitor is activated again automatically when the car is next closed.

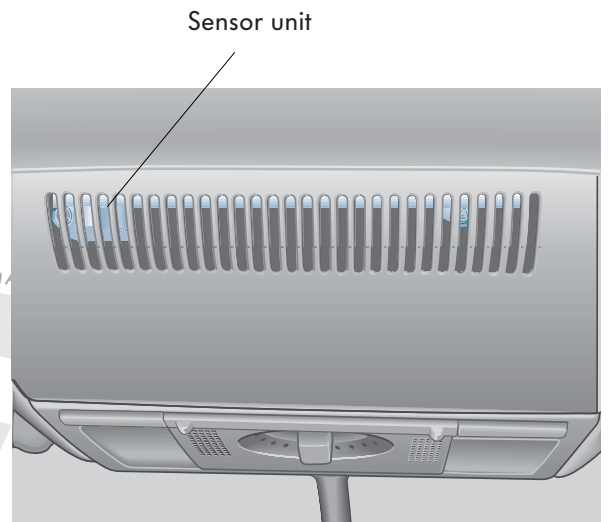

265_051

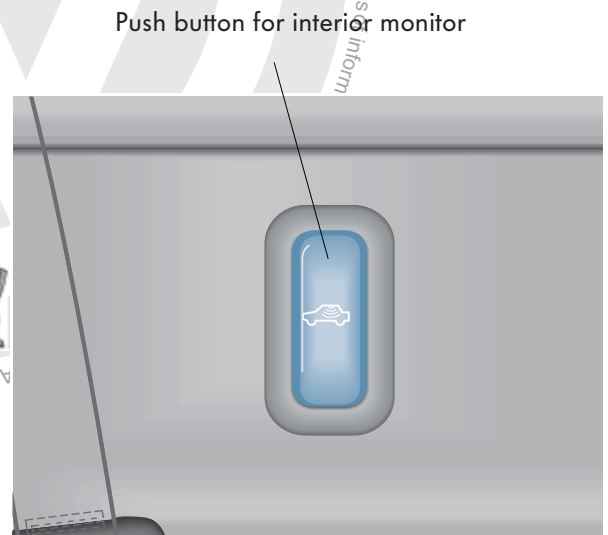

265_055

Sliding/tilting roof

Comfort position

The sliding roof features a comfort position. If the sliding roof adjustment switch in the front interior light is turned into this position, the sliding roof is not opened fully. Consequently, there is scarcely any wind noise inside the car when travelling at higher speeds with the roof set in this position.



The sliding roof adjustment switch cannot be replaced separately in the event of a repair. It is then necessary to replace the complete interior light.



Comfort position

265_079

The sliding/tilting roof offers the following additional functions:

- Closing the sliding/tilting roof as part of the convenience closing function by operating the central locking system
- Function maintained for 10 minutes after ignition is switched off provided none of the front doors is opened
- Force limit if the sliding/tilting roof is obstructed because of difficult operation or because of an obstacle during the closing operation

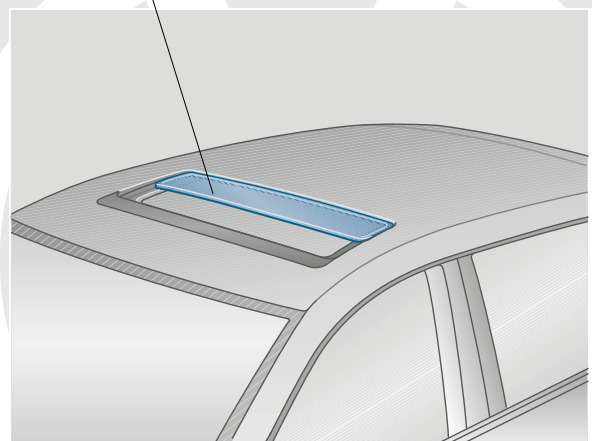

Comfort position

265_080



Protected by copyright. Copying for private or commercial purposes in any form is not permitted unless authorised by Volkswagen AG. Volkswagen AG does not guarantee or accept any liability for the correctness of information in this document. Copyright by Volkswagen AG.

Dash panel insert

The dash panel insert

The following are integrated in the dash panel insert:

- Control unit with display unit in dash panel insert J285
- Immobiliser control unit J362
- Speedometer
- Rev counter
- Fuel gauge
- Coolant temperature display
- Warning lamps
- Multi-function display

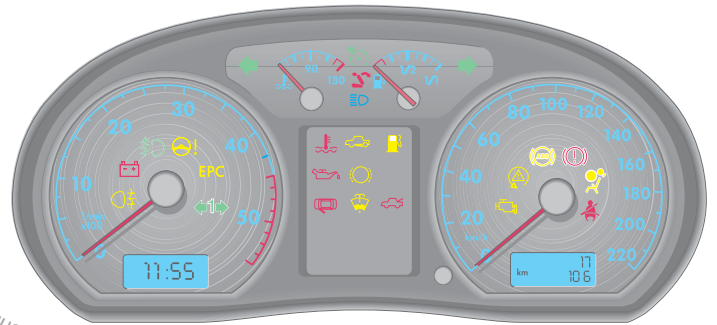

265_026

All the warning lamps feature LEDs. No provision is made for repairs. If necessary, the complete dash panel insert must be replaced.

All the information relating to the monitoring functions is processed in control unit J285 and transmitted to the warning lamps which causes them to light up, flash or show a steady light. Certain visual information is acoustically reinforced by a warning buzzer.



If the dash panel insert is replaced, it has to be adapted to the other systems of the car. Refer to the instructions for this in the Workshop Manual.

The connectors of the dash panel insert

8-pin connector
Link to voltage supply

32-pin connector
Link to onboard power supply

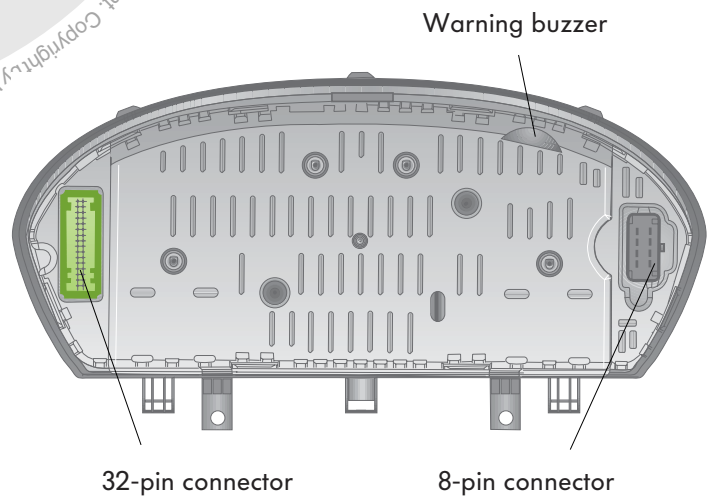

32-pin connector

8-pin connector

265_027

Display symbols

The number and the location of the warning lamps depend on the model and engine version. Warning lamps which are fitted only to certain models are marked with (*).

The symbols are only visible when the corresponding LEDs behind them are illuminated. The ignition must be switched on for this purpose. The table presents new warning lamps which have been added in the Polo Model Year 2002.

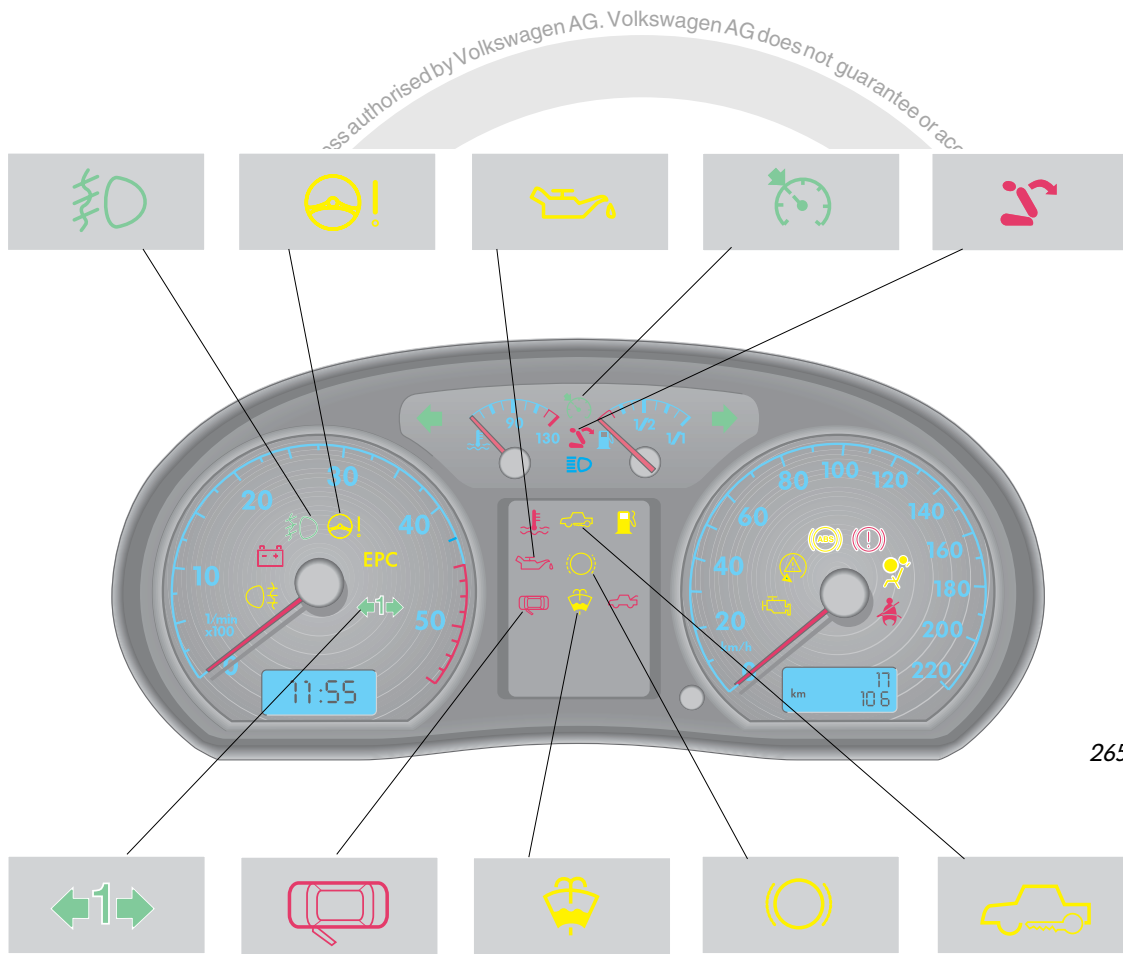







265_028







Display symbol	Designation	Type and meaning of indication
	Fog lights	come on when fog lights operating; switched on by pulling out light switch as far as first detent into side light or low beam position

Dash panel insert

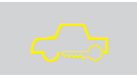
Display symbol	Designation	Type and meaning of indication
	Electrically powered hydraulic steering	lights up for a short time after ignition switched on and goes out after engine started, lights up continuously if fault in steering system; car should be driven to nearest workshop *
	Engine oil level (too low)	lights up yellow if engine oil level is too low; check oil level and replenish if necessary; if bonnet remains open for more than 30 seconds, oil level warning is reset; if no oil has been replenished, warning is displayed again after about 100 km *
	Engine oil level (engine oil level sensor faulty)	flashes yellow, i.e. engine oil level sensor is faulty; audible signal sounds in addition; drive car to nearest workshop *
	Engine oil pressure	flashes red, i.e. engine oil pressure is too low; in addition an audible signal sounds 3 times at engine speeds of more than 1500 rpm; stop; switch engine off! Check oil level and replenish if necessary; if warning lamp continues flashing although oil is at correct level - do not drive car any further!
	Cruise control system	lights up if cruise control system operating *
	Rear seat backrest lock	lights up for about 20 seconds when ignition switched on if backrest of rear seat is not correctly locked; lights up and remains on if backrest is unlocked when driving *

* Models fitted with optional equipment

Display symbol	Designation	Type and meaning of indication
	Electronic immobiliser	lights up for about 3 seconds when ignition switched on; automatic scanning of data of car key performed during this time; if authorized key is detected, car can be started; an alarm activated by the anti-theft system is switched off; if a non-authorized key is detected, car cannot be started and the warning lamp switches to „continuous flashing mode“
	Brake pad wear indicator	lights up if minimum permissible brake pad thickness is reached; car must be driven to nearest workshop to have brake pads inspected or replaced
	Washer fluid level	lights up if insufficient fluid in windscreen washer reservoir; replenish windscreen washer fluid
	Door open	lights up if not all the doors are closed
	Trailer turn signal system	lights up if turn signal system switched on when towing a trailer. If a turn signal light at trailer or car is not operating, warning lamp does not flash.

* Models fitted with optional equipment



Lighting

Headlights

The new headlights are designed as a twin unit and feature clear plastic lenses for the light beams.

The headlight unit has two reflectors. The reflector for main beam and side light is a single chamber, while the reflector for low beam and turn signal light is split into two chambers.

The bulb for the turn signal light is coloured yellow. The light beam is produced by the respective shape of the reflector chamber.

The fog lights are integrated not in the headlight unit but in the bumper.

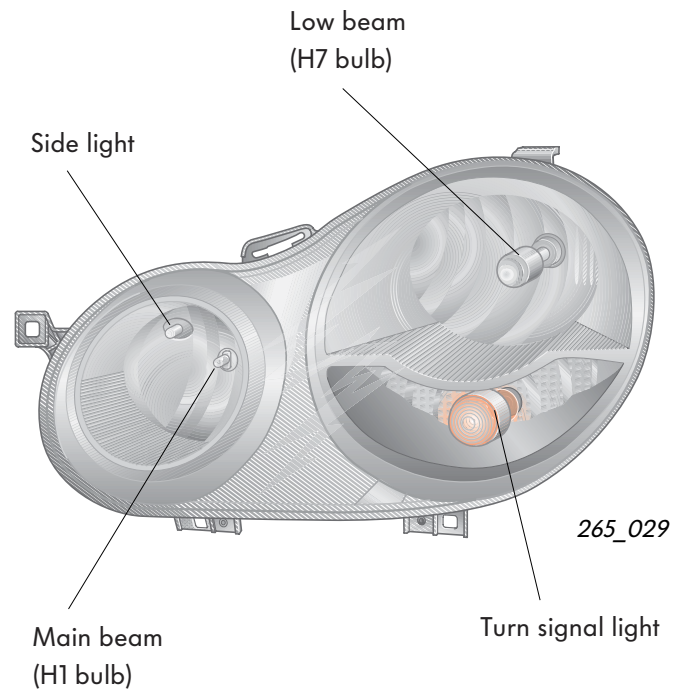

Rear light units

The reflector is a single unit and is divided into four main chambers; the chamber for the tail light/rear fog light is once again divided internally.

The upper half of the chamber includes a bulb for the tail light. The bottom half of the chamber includes a twin-filament bulb for the tail light/rear fog light.

When the lights are switched on, one filament of this twin-filament bulb is illuminated as a tail light together with the tail light in the top half of the chamber.

This provides enhanced safety in the event of one of the tail lights not operating.

When the rear fog light is switched on, the second filament of the twin-filament bulb is also illuminated.

Reflectors are integrated in the full area of the lens of the tail light cluster.



Entry warning lamp

The front doors are equipped with entry warning lamps.

The entry warning lamps offer a clear benefit in terms of safety when using the car in flowing traffic.

The entry warning lamp is switched on through the door contact switch in the lock unit in the door lock.

The convenience system central control unit J393 ensures that the entry warning lamp remains on only for 10 minutes when the car is parked with the doors open. This avoids the battery being discharged.

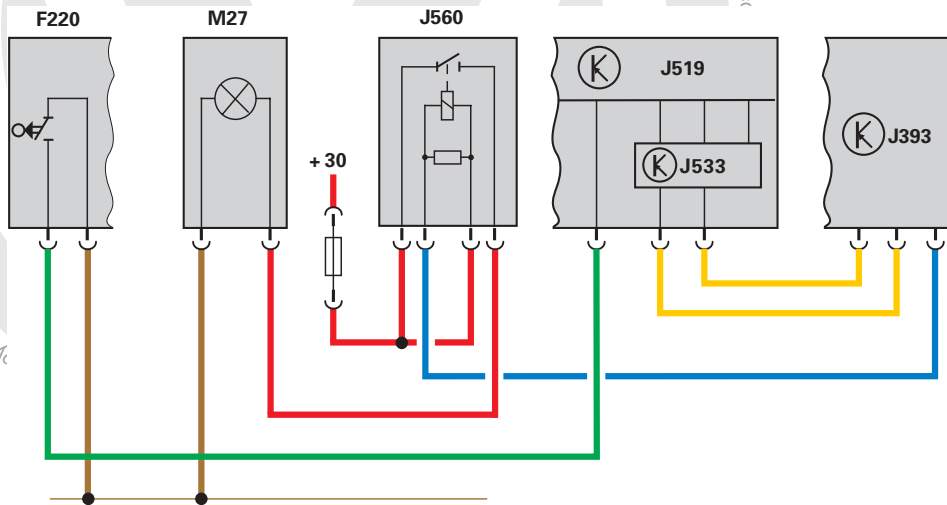
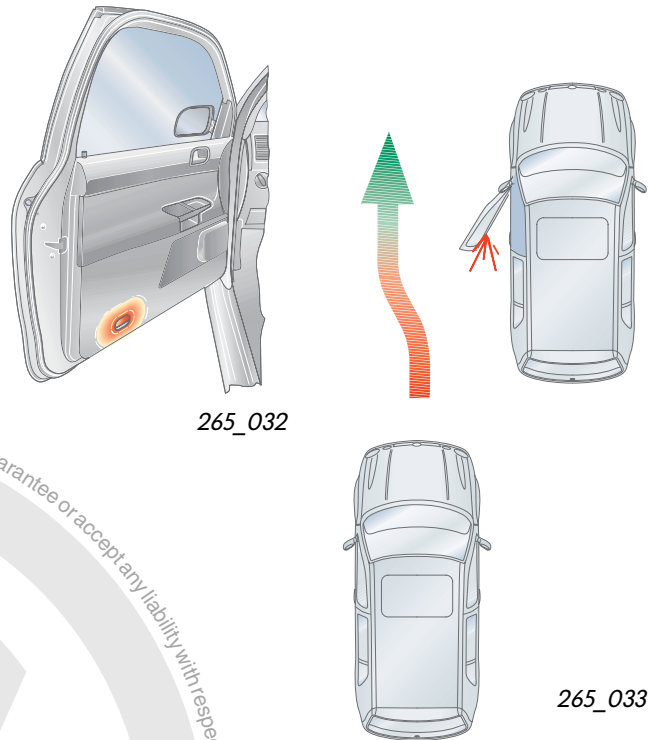

265_034

Electrical circuit (example of driver door)

- F220 Central locking lock unit, driver side
- J393 Convenience system central control unit
- J519 Onboard power supply control unit
- J533 Databus diagnostic interface
- J560 Relay for warning lamps, doors
- M27 Entry warning lamp - left door

Colour coding/Legend

- █ = Input signal
- █ = Output signal
- █ = Positive
- █ = Earth
- █ = CAN databus



Self-diagnosis

Control units in the Polo with self-diagnosis capability

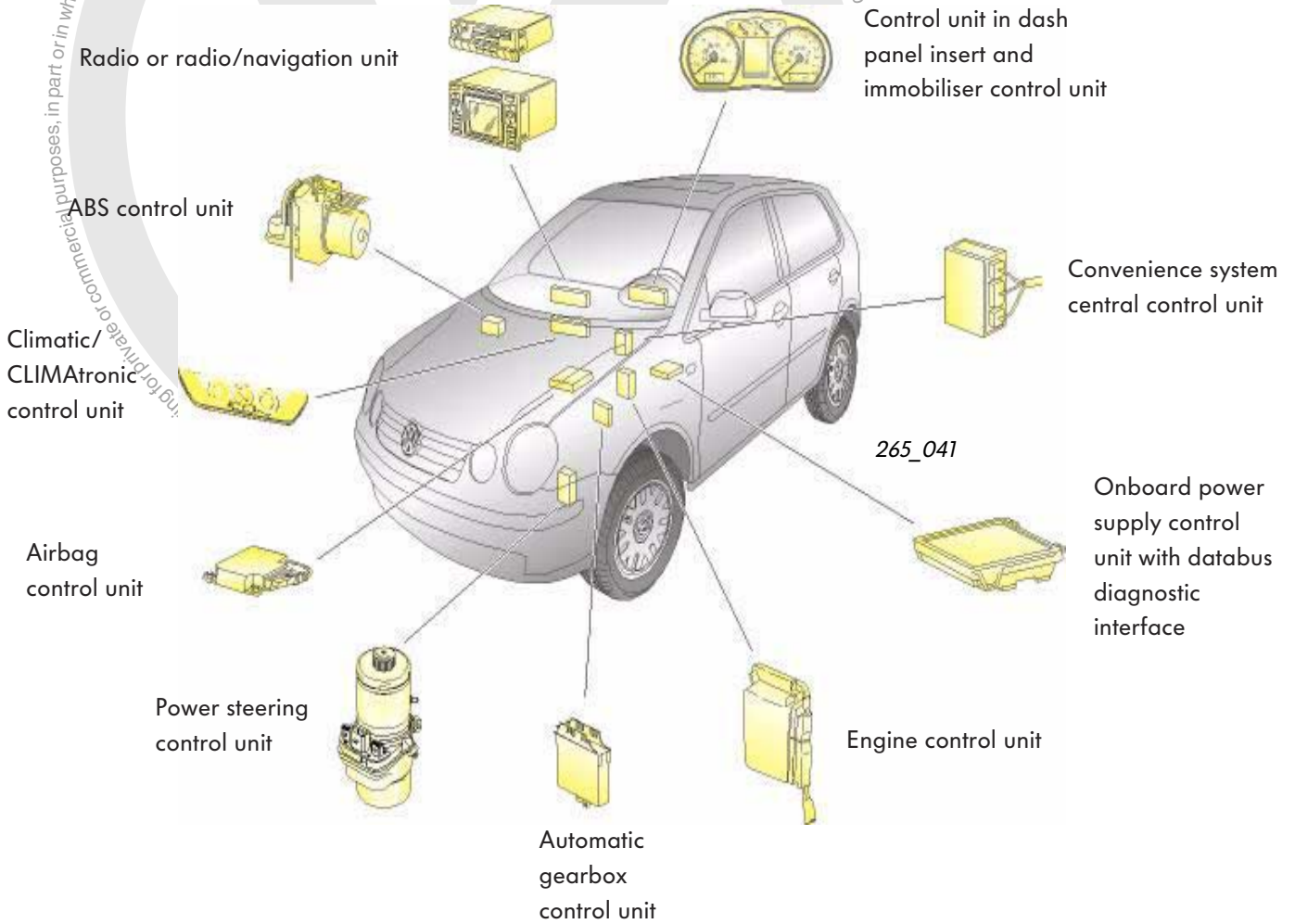

For diagnosis please use the up-to-date workshop literature and the Vehicle Diagnostic, Testing and Information System VAS 5051 or the Vehicle Diagnostic and Service Information System VAS 5052.



265_054

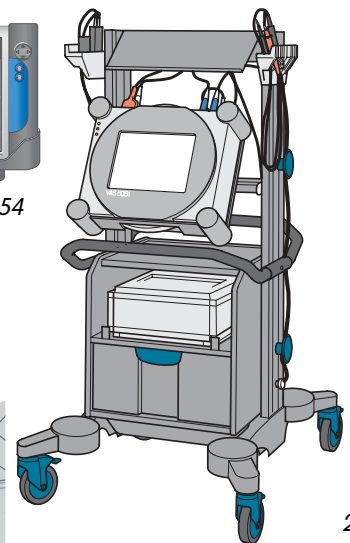

265_042



The connection for the diagnostic units is located between the storage compartment in the dash panel cover on the driver side.

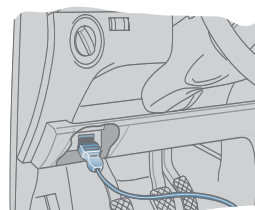

265_043



Test your knowledge

Which answers are correct?

Sometimes only one.

But perhaps also more than one – or all of them!

1. The onboard power supply control unit ...
 - A. replaces the convenience system central control unit.
 - B. is the central monitoring and control unit of the onboard power supply.
 - C. controls the power demand of the onboard power supply.

2. The databus diagnostic interface ...
 - A. transmits the diagnostic data of the K wire over the CAN and vice versa.
 - B. monitors the function of the onboard power supply control unit.
 - C. is the connection point of the CAN databus systems.

3. There are two CAN databus systems in the onboard power supply operating ...
 - A. each on their own.
 - B. together through the connections of the compact connectors.
 - C. together through the gateway in the onboard power supply control unit.

4. The tasks of the compact connector in the bulkhead consist of ...
 - A. connecting the „engine compartment“ and „interior“ sections of the wiring looms.
 - B. facilitating service work.
 - C. creating installation space.

5. The code numbers are ...
 - A. secret numbers for the operation of the immobiliser.
 - B. count numbers transmitted to the control units.
 - C. values for coding control units in accordance with the vehicle equipment.



6. The drivetrain CAN databus operates with...
- A. a transmission rate of 500 kBit/s.
 - B. a transmission rate of 100 kBit/s.
 - C. a transmission rate of 50 kBit/s.
7. The wake-up function is designed to ...
- A. wake up the driver out of the „sleep state“.
 - B. wake up the control units connected to the CAN databus systems out of the „sleep state“.
 - C. control the fuel pump supply.
8. The entry warning lamp is switched off automatically at a certain time if a door is open ...
- A. by the onboard power supply control unit.
 - B. by the databus diagnostic interface.
 - C. by the convenience system central control unit.
9. The following conditions must be met in order to create the „sleep state“ ...
- A. ignition „Off“.
 - B. warning light system „Off“.
 - C. exterior light „Off“.
10. The interior monitoring system includes ...
- A. alarm horn.
 - B. signal horn control.
 - C. sensor unit.

Answers: 1. B.; 2. A., C.; 3. A., C.; 4. A., B., C.; 5. C.; 6. A.; 7. B.; 8. C.; 9. A., B., C.; 10. A., C.

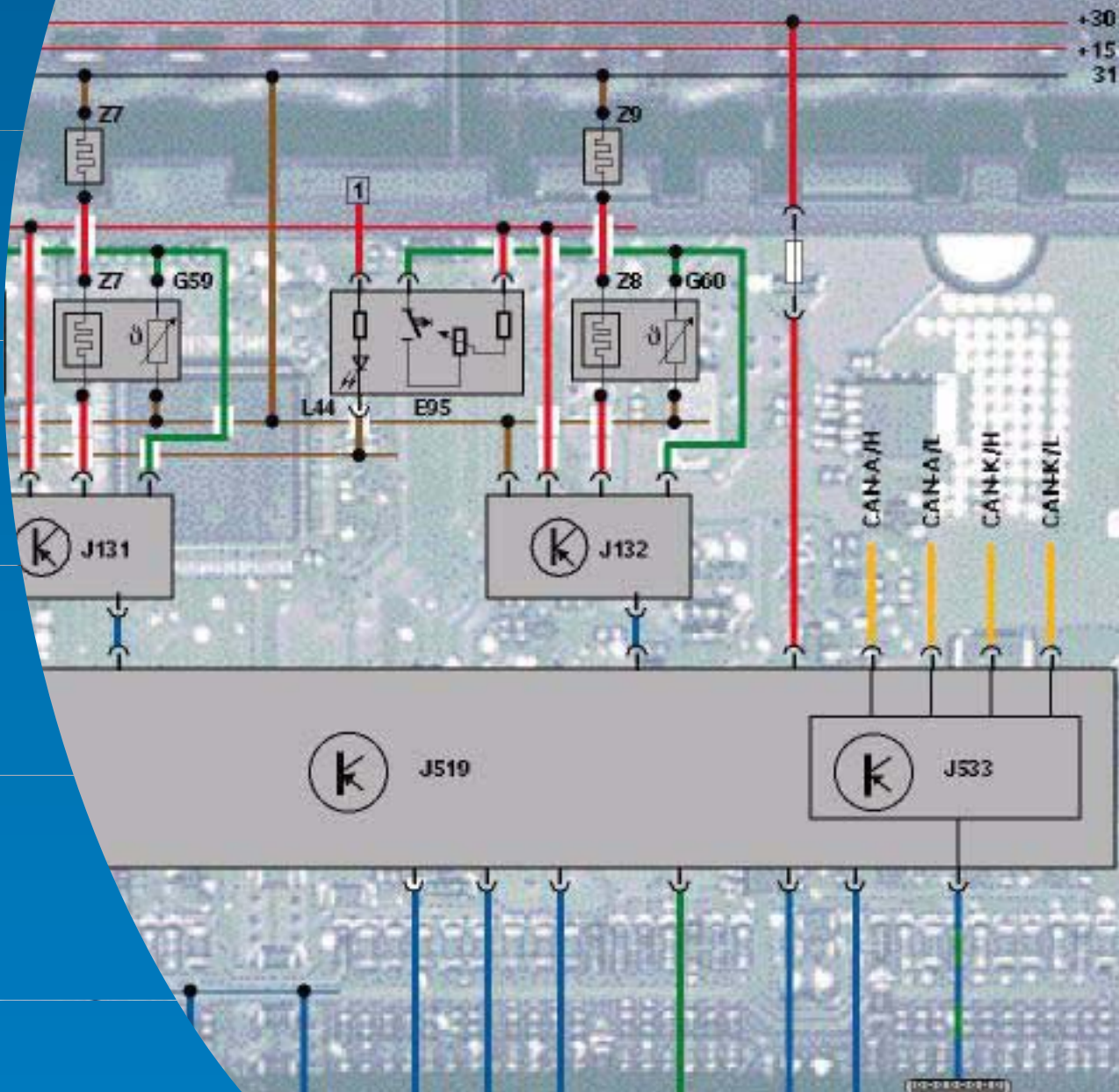

For internal use only © VOLKSWAGEN AG, Wolfsburg

All rights reserved. Technical data subject to change without notice

140.2810.84.20 Corresponds to technical state 10/01

♻️ This paper was produced from chlorine-free chemical pulp.