

Service.



Self-Study Programme 261

The Passat W8



The Passat W8



S261_002

This Self-Study Programme presents the Passat W8. We will only explain the design and function where the items are totally new. All the changes described refer to the Passat model year 2001.

The subject of the W8 engine is described in two separate Self-Study Programmes:

- Self-Study Programme No. 248
"The W Engine Concept"
- Self-Study Programme No. 249
"The W8 Engine Management"

NEW

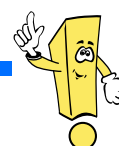

**Caution
Important**



**This Self-Study Programme explains the design and function of new developments.
The contents of this book will not be updated.**

Please always refer to the relevant Service literature for up-to-date inspection, adjustment and repair instructions.

At a glance



In a nutshell4



Body10



Occupant protection12



Drive units 15



Power transmission22



Running gear24



Vehicle electrical system 30



Convenience and safety electronics33



Heating and air conditioning system44

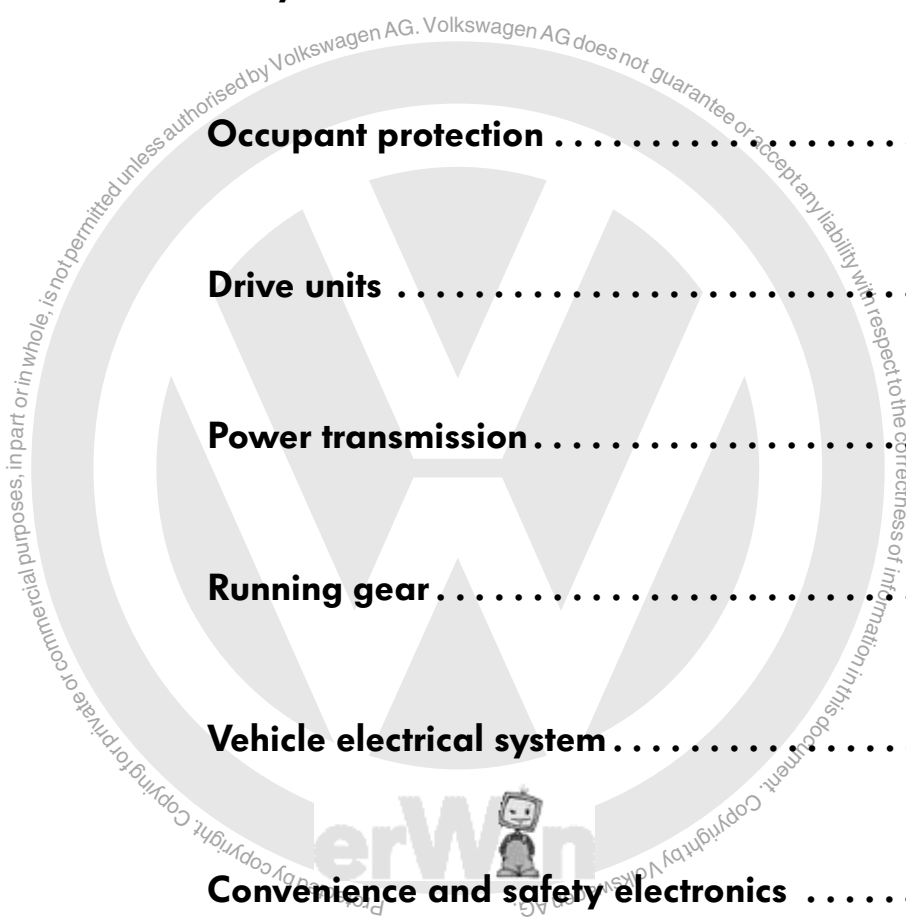

In a nutshell



The Passat W8

The top model of the Passat range is the first car from Volkswagen equipped with an 8-cylinder engine. The Passat W8 offers luxury class refinement in performance, comfort, safety, quality and equipment. It will be offered in saloon and estate versions.

Innovations in the Passat W8

- 6-speed manual gearbox or 5-speed automatic with Tiptronic
- Special crash and acoustic measures
- W8 engine 4.0 l/202 kW (275 bhp) 4 valve per cylinder
- Fuel tank 80 l
- Climatronic
- Bi-xenon headlights
- Four-wheel drive 4 Motion
- Exhaust system with 2 chrome tailpipes
- 7.5 J17" alloy wheels with 225R/45 tyres

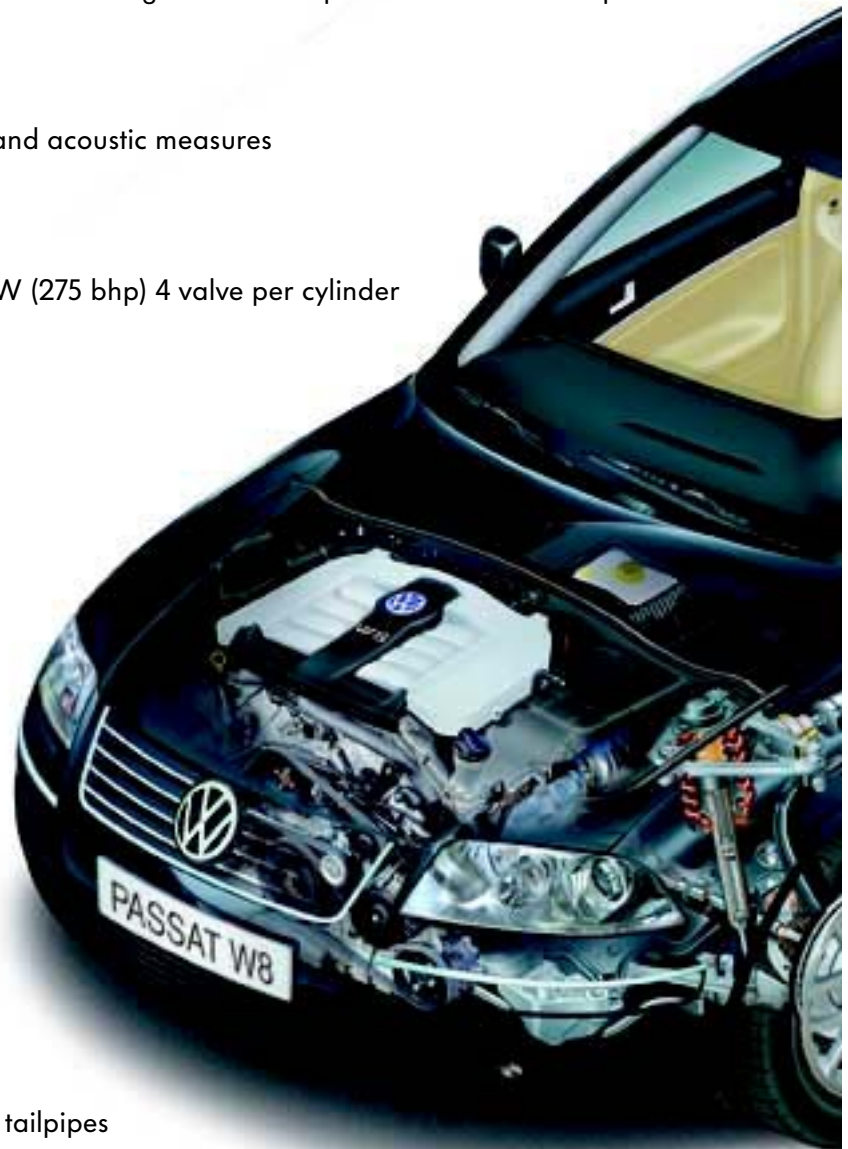

whole, is not permitted unless authorised by Volkswagen AG. Volkswagen AG does not guarantee or accept any liability with respect to the content of this document.



This high-quality car is based on the Passat launched in model year 2001.

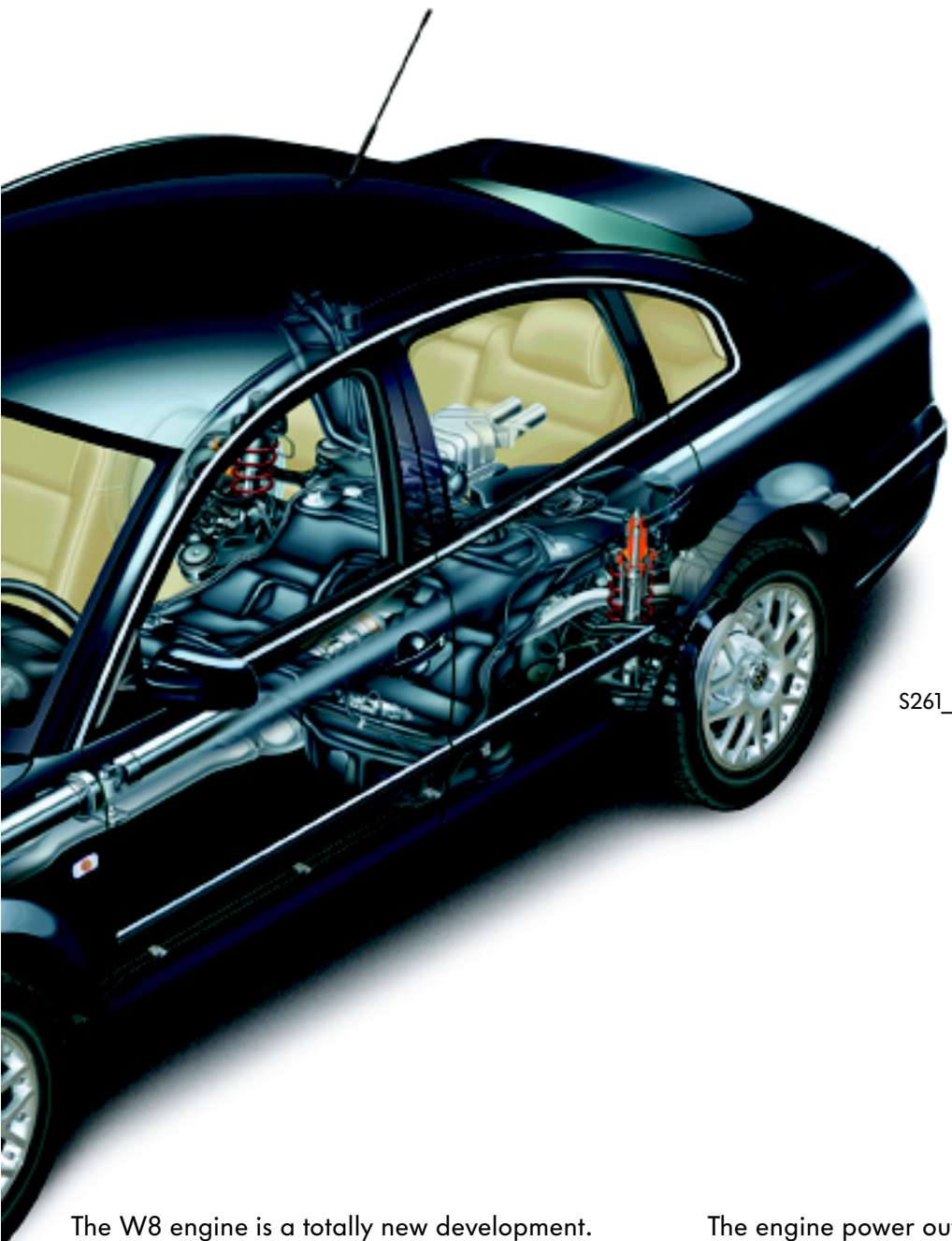

S261_003

The W8 engine is a totally new development. One of the technical features is its compact size.

The engine power output is transferred to the road via a 6-speed manual gearbox with four-wheel drive (4Motion). Optionally there is a five-speed automatic gearbox with Tiptronic and 4Motion.

In a nutshell



The Estate

All the innovations in the Passat W8 saloon are also in the estate. The bodies of both the estate and the saloon have been strengthened to improve the acoustics and increase crash safety.

But whether it is the estate or the saloon, the new Passat W8 is recognisable from the outside by its two chrome twin exhausts, the bi-xenon headlights, additional chrome trims and the 17 inch alloy wheels.

permitted unless authorised by Volkswagen AG. Volkswagen AG does not guarantee or accept any liability





Inside, the standard equipment includes head airbags front and rear, high-class pillar and headliner trims, chrome and real wood trims, exclusive upholstery, an on-board computer and automatic air conditioning.

In the extensive list of the Passat W8's optional extras we have included new luxury leather seats, new sports seats, a dynamic navigation system with audio, TV unit and Internet access, a digital sound pack and dark tinted rear windows.

art or in whole, is not permitted. Volkswagen does not guarantee or accept any liability with respect to the contract.



S261_004

In a nutshell



The Saloon

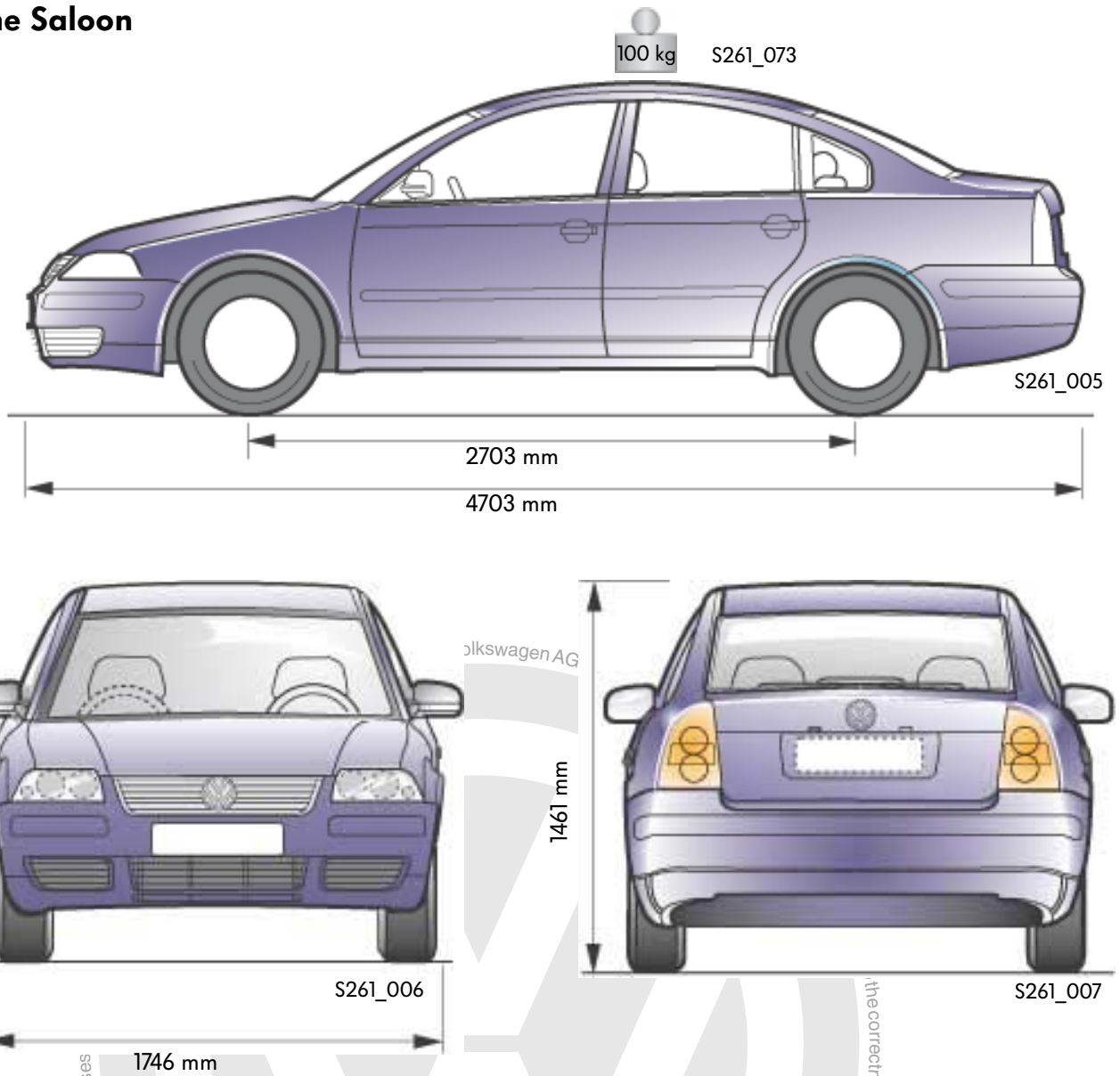

Size and weight

Length	4703 mm
Width	1746 mm
Height	1461 mm
Wheelbase	2703 mm
Turning circle	11.5 m
Tank capacity	80 l

Front track width	1511 mm
Rear track width	1510 mm
Perm. gross vehicle weight	2220 kg
Kerb weight	1665 kg
Permitted roof load	100 kg
Drag coefficient	0.27 c_d

The Estate

100 kg

S261_073

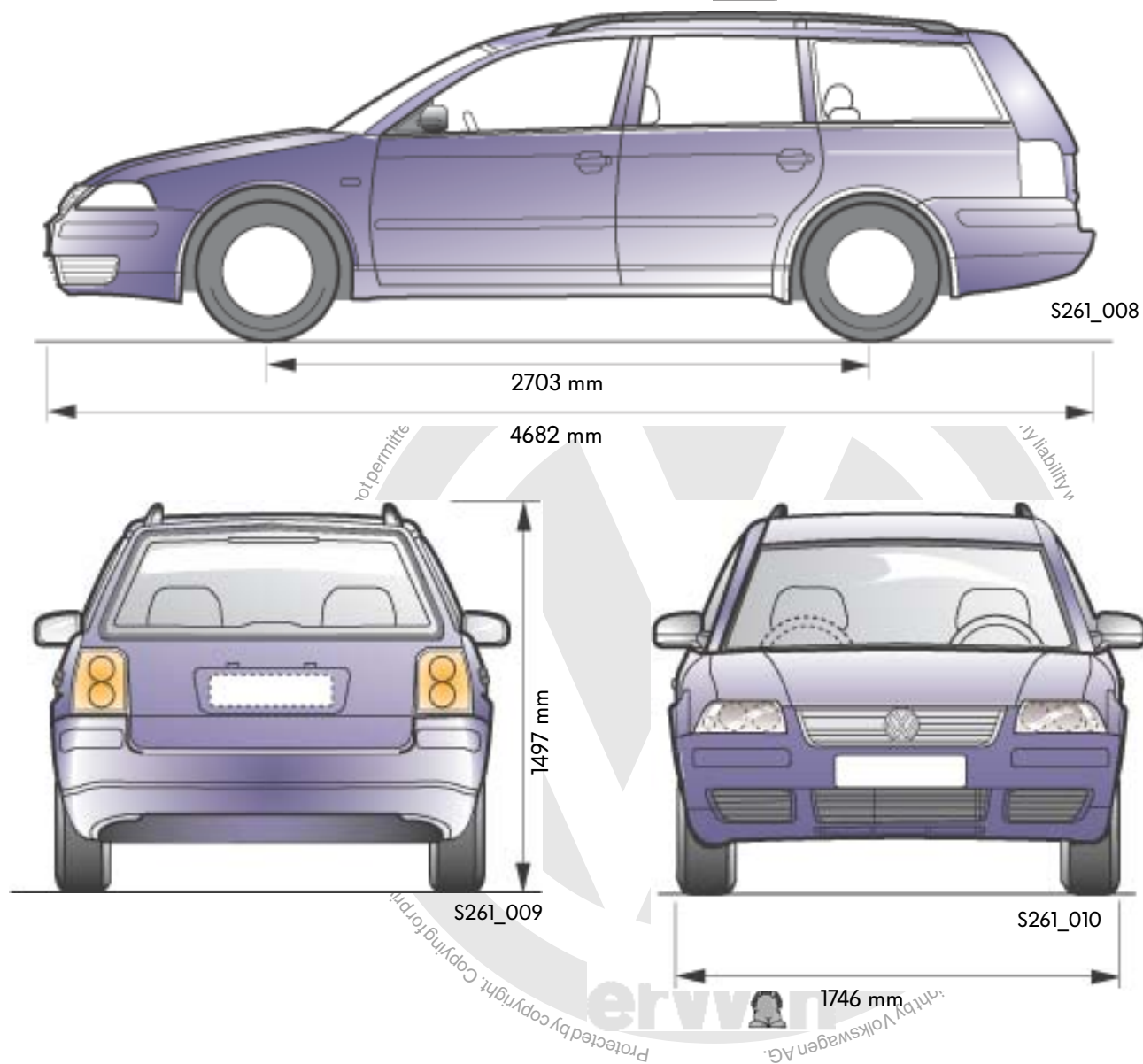

Size and weight

Length	4682 mm
Width	1746 mm
Height	1497 mm
Wheelbase	2703 mm
Turning circle	11.5 m
Tank capacity	80 l

Front track width	1515 mm
Rear track width	1510 mm
Perm. gross vehicle weight	2290 kg
Kerb weight	1725 kg
Permitted roof load	100 kg
Drag coefficient	0.27 c_d

Body

Body modifications

To fulfill the claims of greater luxury and safety, the body of the Passat W8 has been strengthened. By strengthening, we make a distinction between reinforcement to improve the acoustics and reinforcement to increase crash safety.

We have modified the spare wheel well to attach the auxiliary fuel tank. On the saloon, the rear bulkhead is welded to the rear backrest. The backrest of the rear seat bench is therefore not foldable.

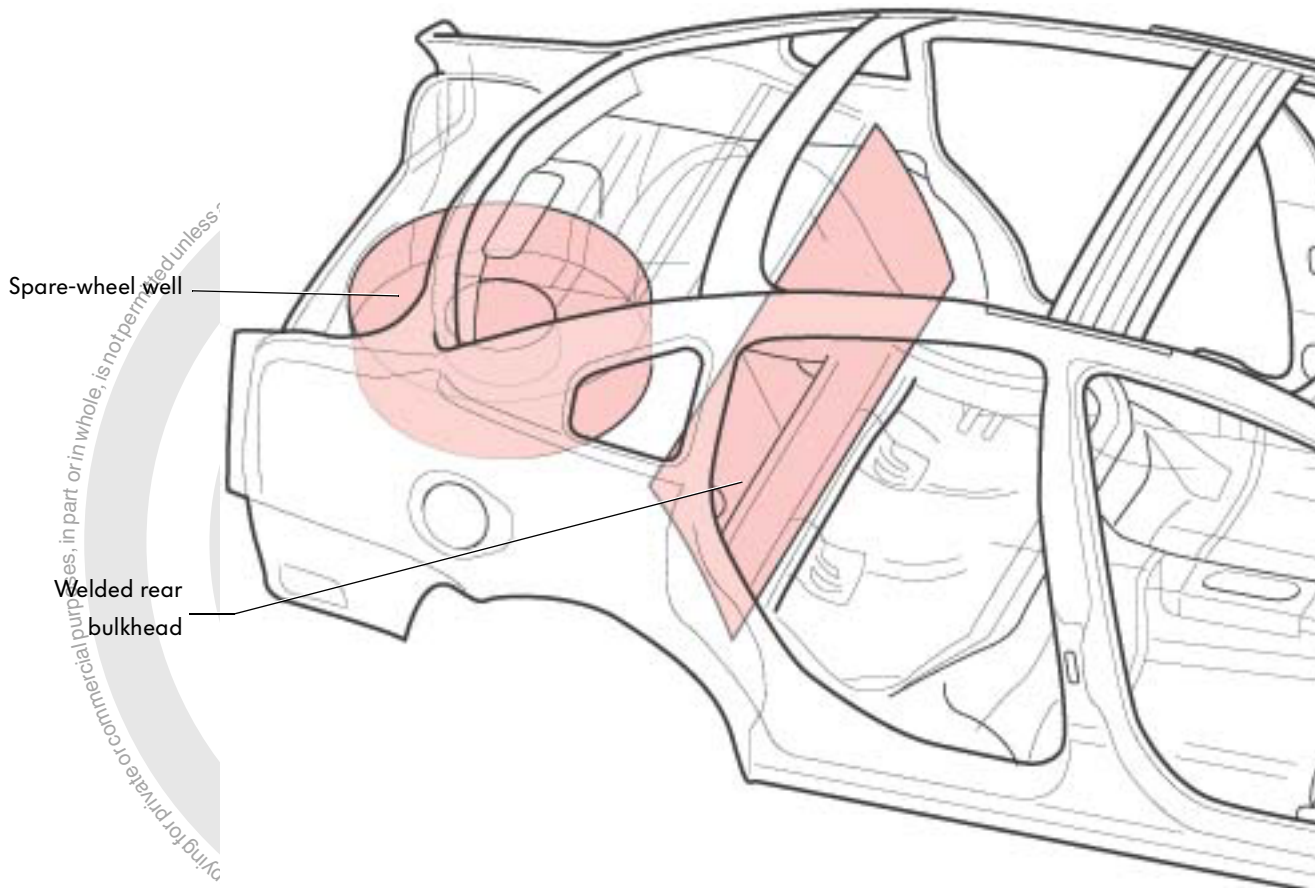

The cross strut between the front wheel housings is also enclosed on cars fitted with a V6 engine (petrol and diesel models).

Acoustic measures:

A cross strut is bolted between the front wheel housings. It is fixed to new supports welded to the wheel housings. An additional strut is welded to the front bulkhead near the front side member.

Crash reinforcements:

The front footwell is reinforced by an additional cross-member.

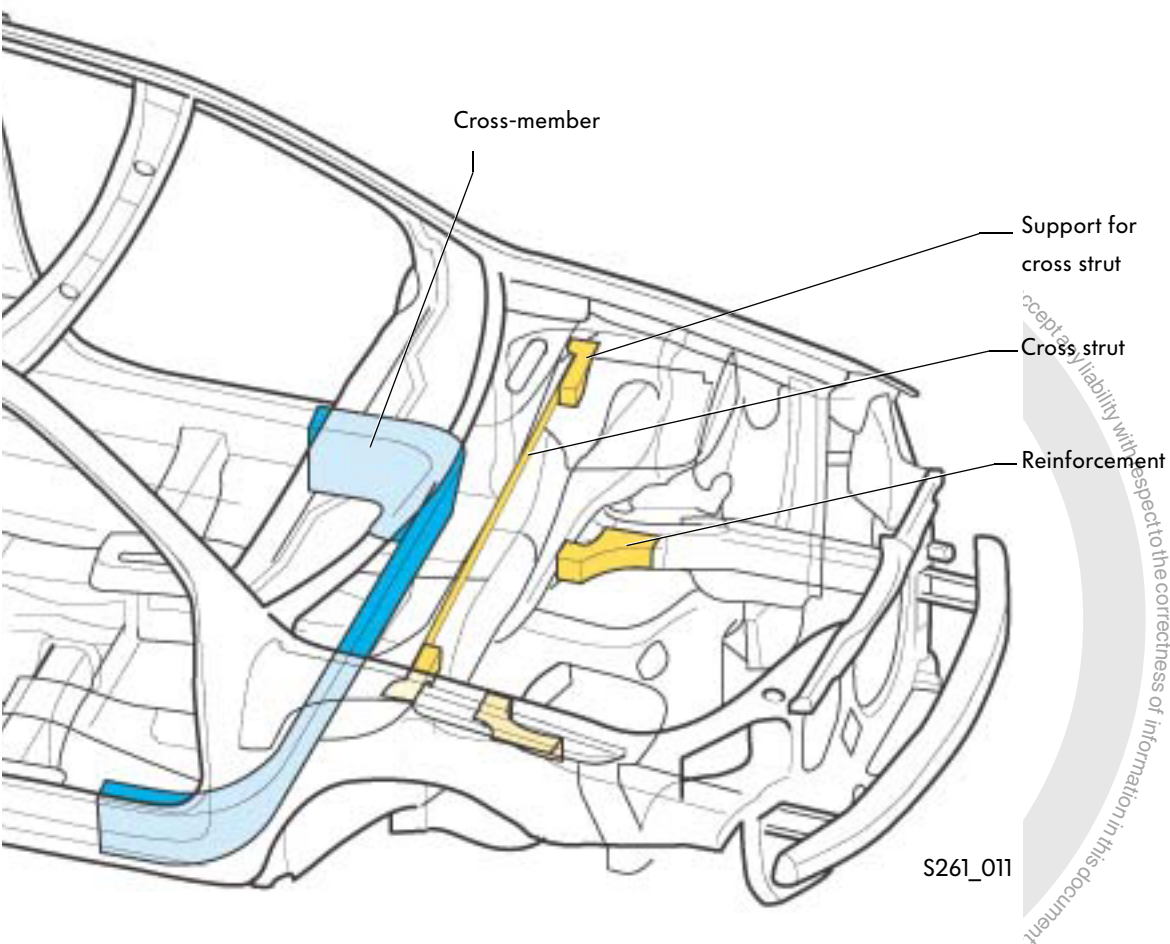

-  Body modifications
-  Crash reinforcements:
-  Acoustic measures

Occupant protection

Occupant protection

Occupant protection is ensured by the airbag system with two front airbags, sidebags and head airbags, belts and belt tensioners as well as the child safety restraint system.

The Passat W8 has two full size front airbags on the driver's and front passenger's sides. They have a filling volume of 64 and 120 litres. The central airbag control unit is located behind the central console on the tunnel.



This information is for informational purposes only. Volkswagen AG does not guarantee or accept any liability for the use of this information for legal or commercial purposes, in part or in whole, is not permitted unless authorised by Volkswagen AG.

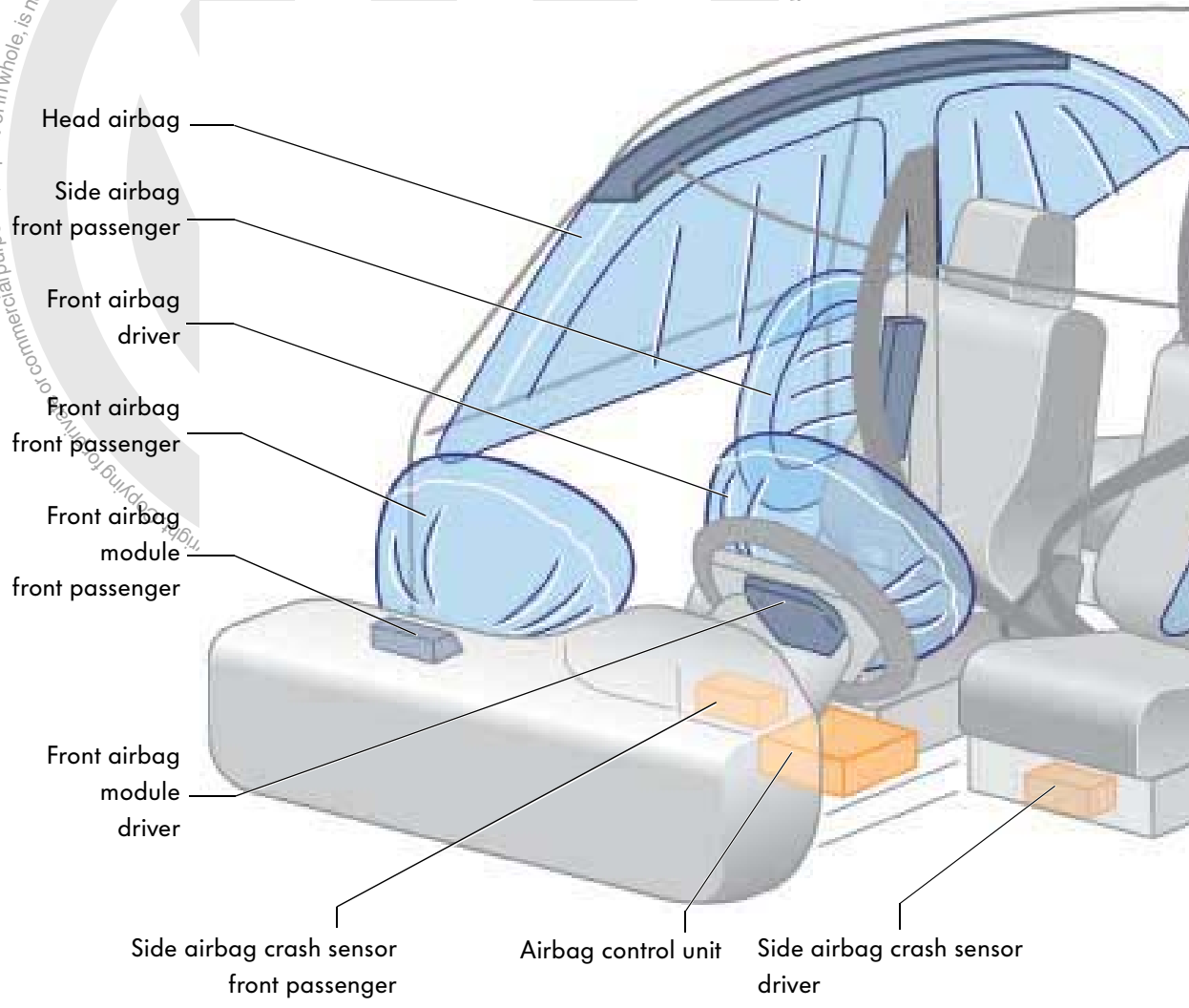

The two side airbags are located in the front seats and have a filling volume of 12 litres. The head airbags each have a filling volume of 26 litres and are mounted in the vehicle headlining above the doors.

The system has 2 lateral acceleration sensors which are located below the front seats as on the previous model.

The conventional inertia-reel seat belts are used on the front and outer rear seats. Ball-type tensioners are fitted to the front seats.

The rear seats are fitted with Wankel belt tensioners. The two types of belt tensioner are triggered by mechanical/pyrotechnical capsules.

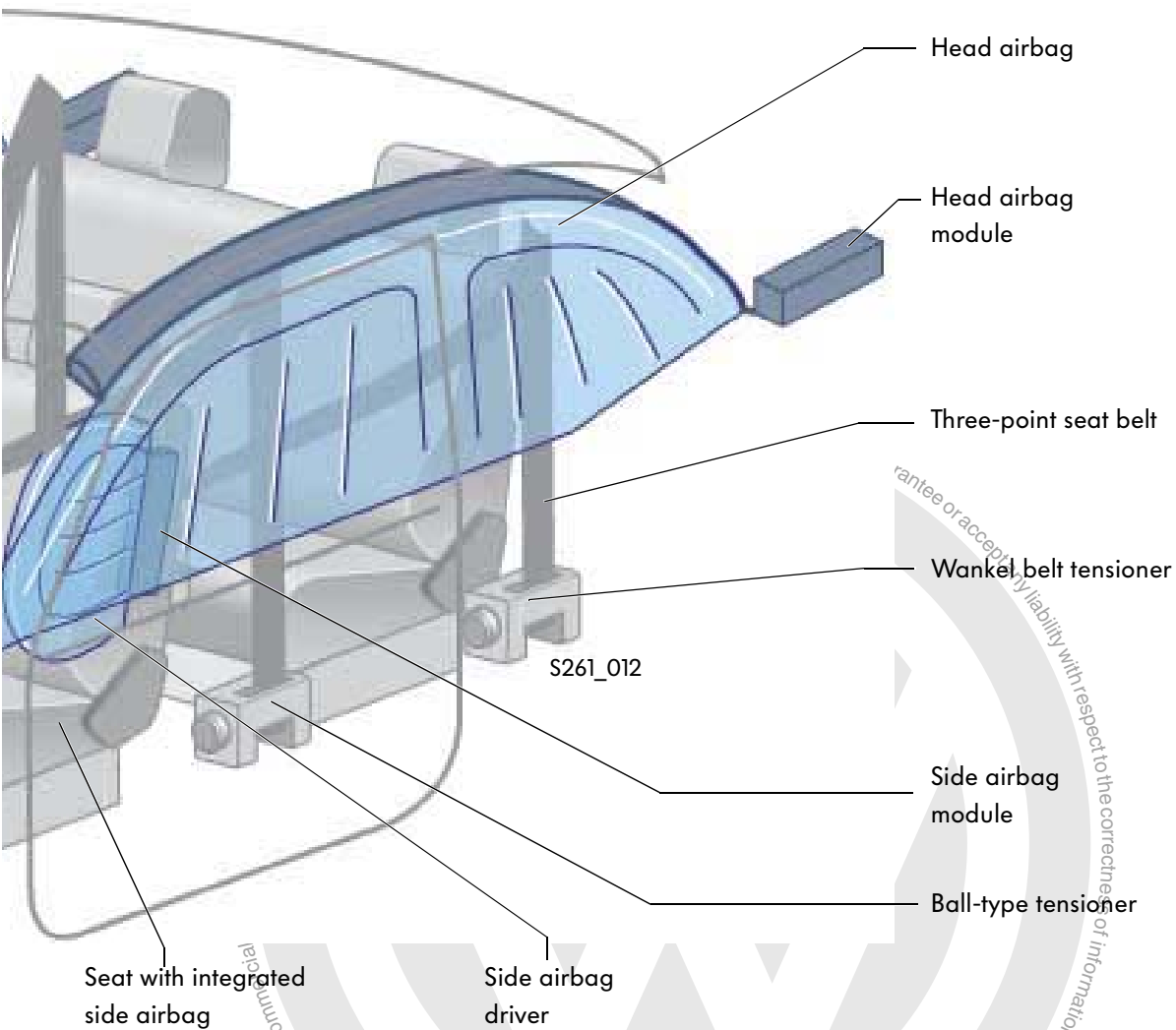

The top part of the seat belts on the new Passat is flexible. The bottom part is bolted rigidly to the brackets.

Occupant protection

Child safety restraint system

Both the integrated child safety seats and the Isofix system are available on the Passat W8.

Integrated child safety seats

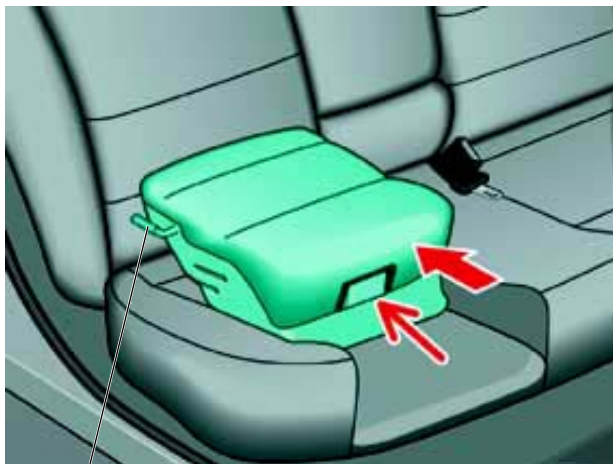

Belt guide hook

S261_013

To use the integrated child safety seat, the swab elements must be raised and engaged. The correct belt run is corrected by an additional shoulder belt guide for children measuring 1.3 m to 1.5 m tall. A belt guide hook on the raised swab ensures that the belt runs safely across the child's lap.

The Isofix System



S261_014

The new Passat W8 is fitted both with a standard preparation for receiving the ISOFIX system retaining eyes as well as integrated child safety seats in the rear seats as an optional extra.

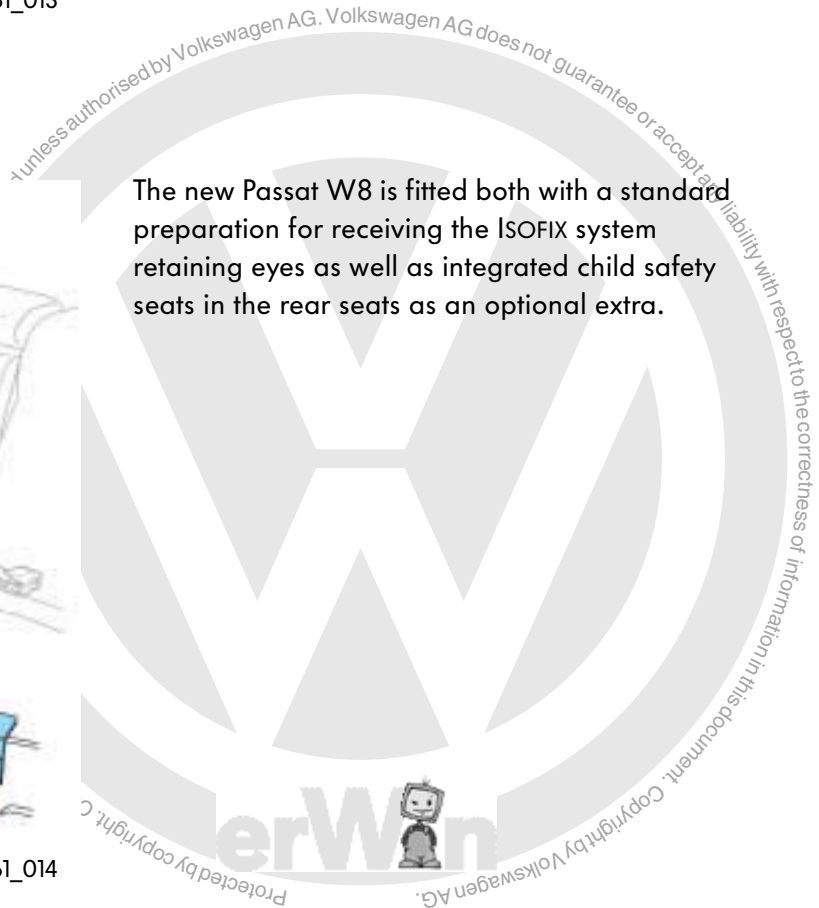

The W8 engine in general

The Passat W8 is fitted with one engine, the new W engine generation, the W8. The W layout is obtained by joining two V engines at an angle of 72°. This layout achieves a very compact 8-cylinder engine with very small dimensions.

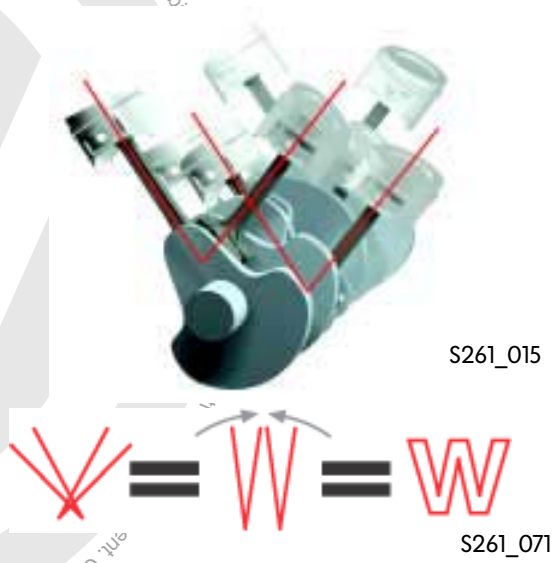

Compared with other 8-cylinder engines, the W8 is very lightweight due to the short size and through the use of aluminium, slim conrods and short pistons.

Four valves per cylinder, low-friction roller rocker fingers, chain drive for the four overhead camshafts with camshaft timing adjuster are some of the noticeable features of this modern engine.



For more details, refer to Self-Study Programme No. 248.

Drive units

Specifications

Engine code	BDN
Displacement	3,999 cm ³
Type	W engine
Valves per cylinder	4
Compression ratio	10.75±0.25:1
Bore	84.0 mm
Stroke	90.2 mm
Max. output	202 kW / 275 bhp 6000 rpm
Max. torque	370 Nm 2750 rpm
Engine management system	Motronic M7.11
Fuel	RON 98 (reduced output with RON 95)
Exhaust gas aftertreatment	Three-way catalytic converter with Lambda control

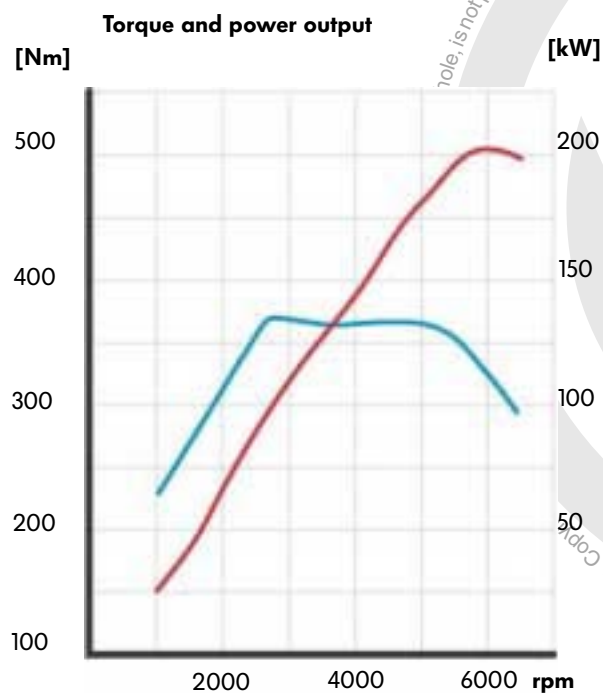

The power output of the W8 engine is 202 kW or 275 bhp at 6000 rpm. Referred to the displacement, it has a power output per litre of 50.5 kW or 68.7 bhp.

The 4.0 l W8 engine develops a maximum torque of 370 Nm at an engine speed of 2750 rpm. Referred to a displacement of 3999 cm³ this results in a special maximum torque of 92.5 Nm/l.

- Torque curve
- Output curve

S261_017

The fuel delivery system

The fuel delivery system of the Passat W8 has tank capacity of 80 litres. It consists of a 60 litre fuel tank as fitted to the Passat 2001 4Motion and an additional tank containing 20 litres.

The two fuel tanks are connected by a connecting tube. The additional fuel tank is located under the spare-wheel well which is reduced in size for this reason. If the car has a puncture, there is an emergency wheel available in the reduced spare-wheel well.

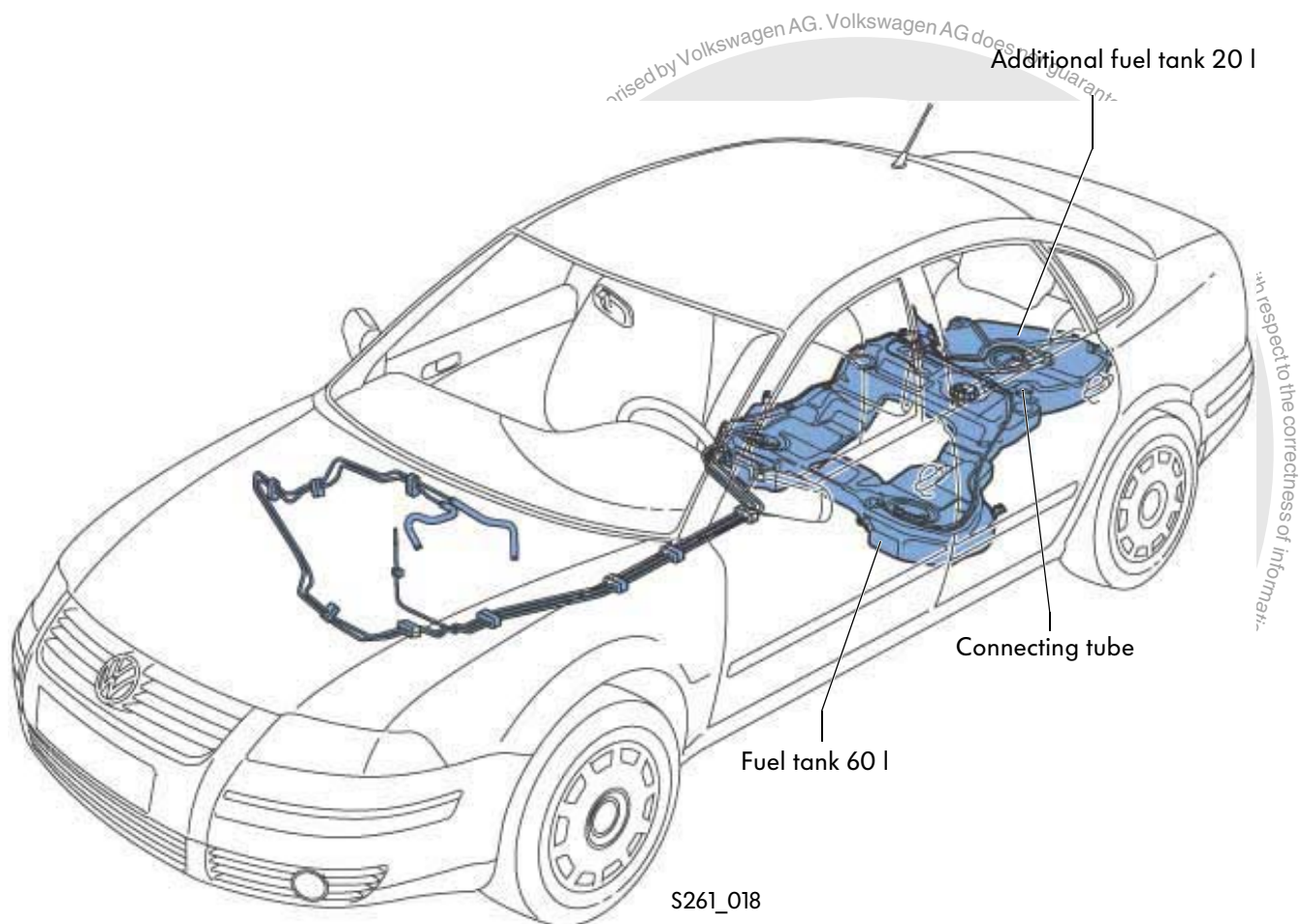

Drive units

The fuel pumps

The 60-litre fuel tank contains an electrical fuel pump and a suction jet pump (entrainment pump). There is another electrical fuel pump in the 20-litre additional fuel tank. The different heights of the main tank and the additional tank require a controlled evacuation of the two tanks. The engine is always supplied with fuel by the pump in the 60 l tank.

When the tank is full, fuel is first pumped from the 60 l tank. When the fuel level in the main tank drops to 40 litres, the fuel pump in the additional fuel tank cuts in and pumps fuel from the additional tank to the main tank. When the additional fuel tank is empty, the remaining fuel is pumped from the main tank. The suction jet pump (entrainment pump) delivers fuel from the left chamber in the main tank to the fuel pump.

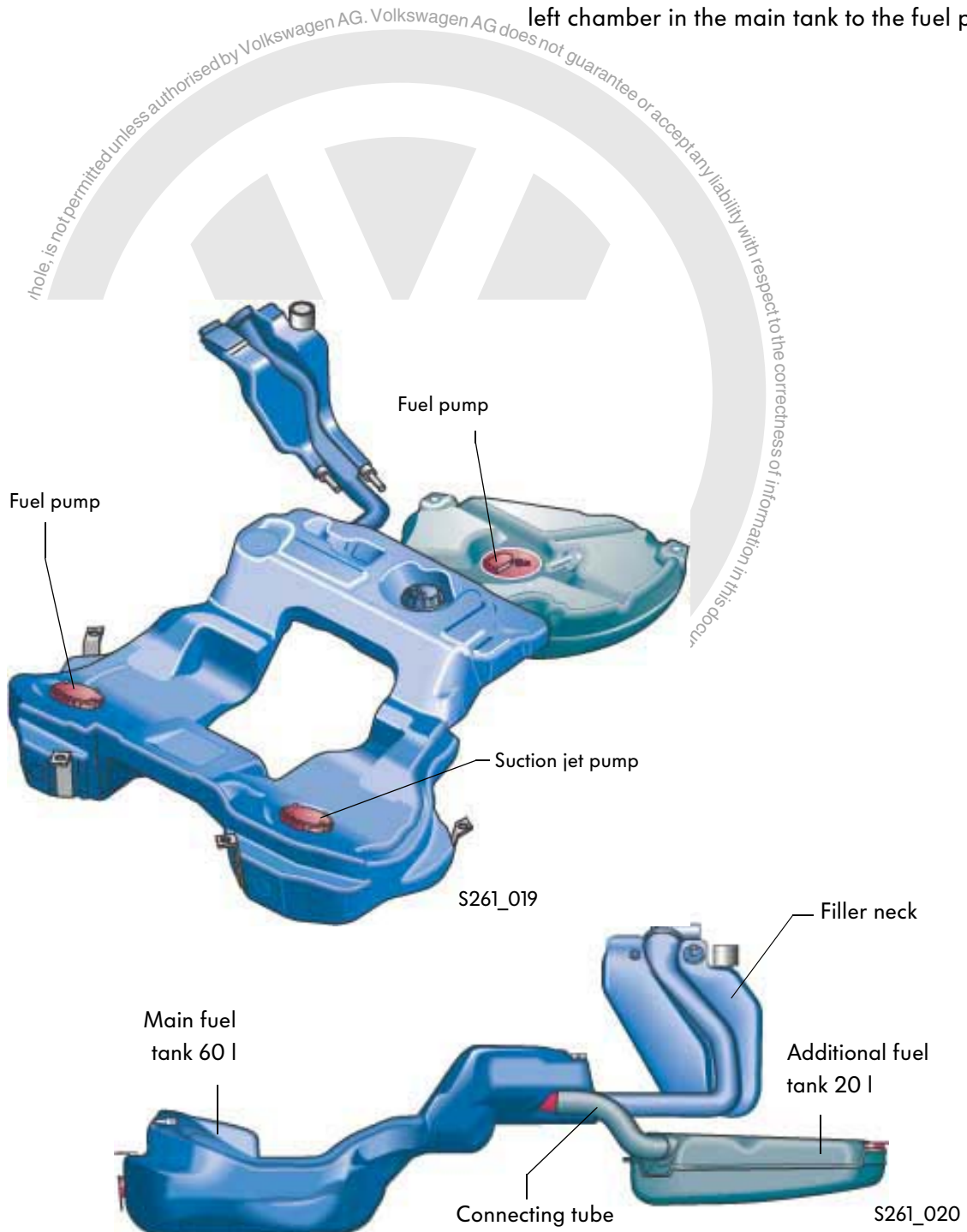

Fuel pump control

The fuel pump in the main fuel tank is controlled by the engine control unit. The fuel pump in the additional fuel tank is switched on by the fuel pump control unit. For this reason there are four fuel level senders in the entire tank and one sender G293 with a Reed contact. The signals from all the senders are sent to the fuel pump control unit.

When the sender in the main fuel tank signals a fuel level of 40 litres, the control unit switches the pump in the additional fuel tank on. It pumps fuel from the additional fuel tank to the main fuel tank until the sender G293 signals "Additional fuel tank empty". Then the control unit switches the pump in the additional fuel tank off. This prevents the pump from running in an empty tank as well as noise and additional power consumption.

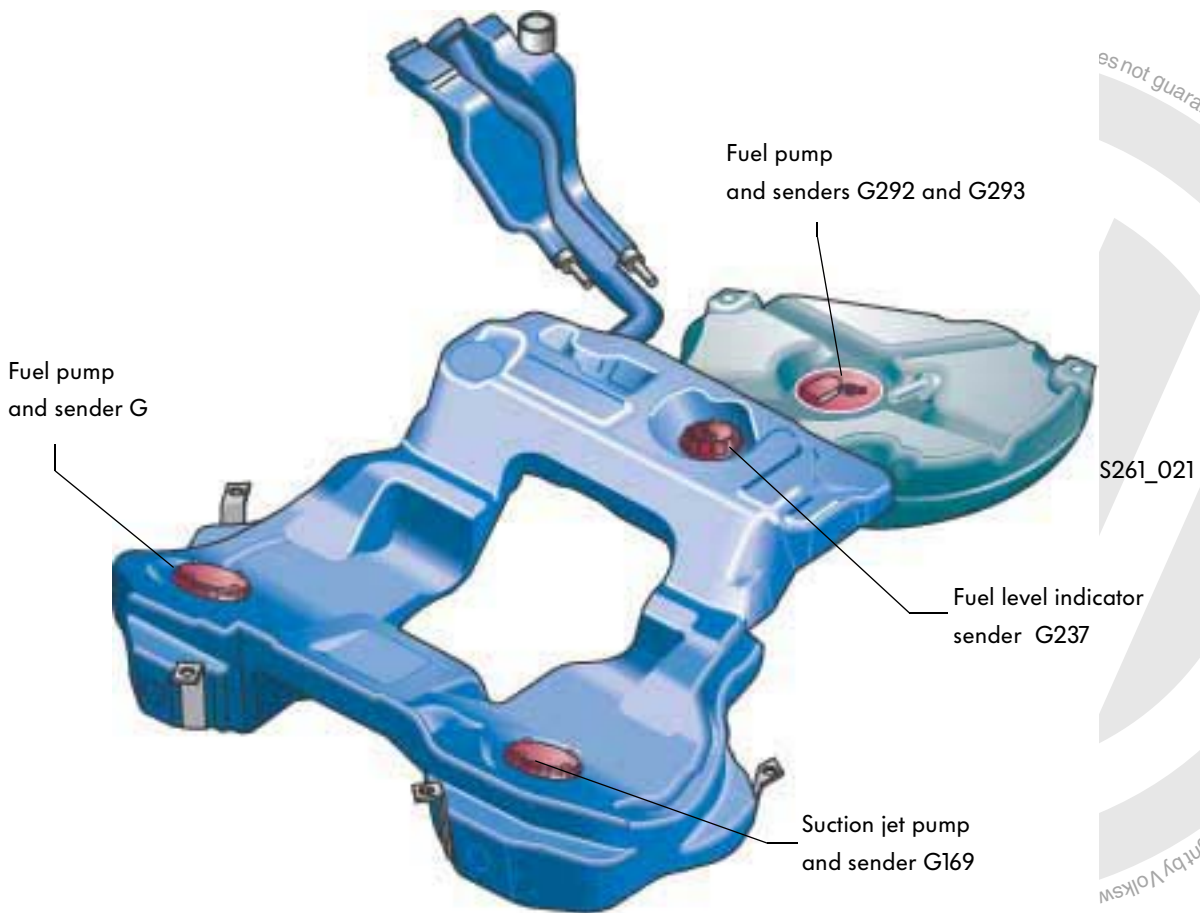

es not guarantee or accept any liability with respect to the correctness of information in this document. Copyright by Volkswagen

Drive units

Function diagram of fuel delivery system

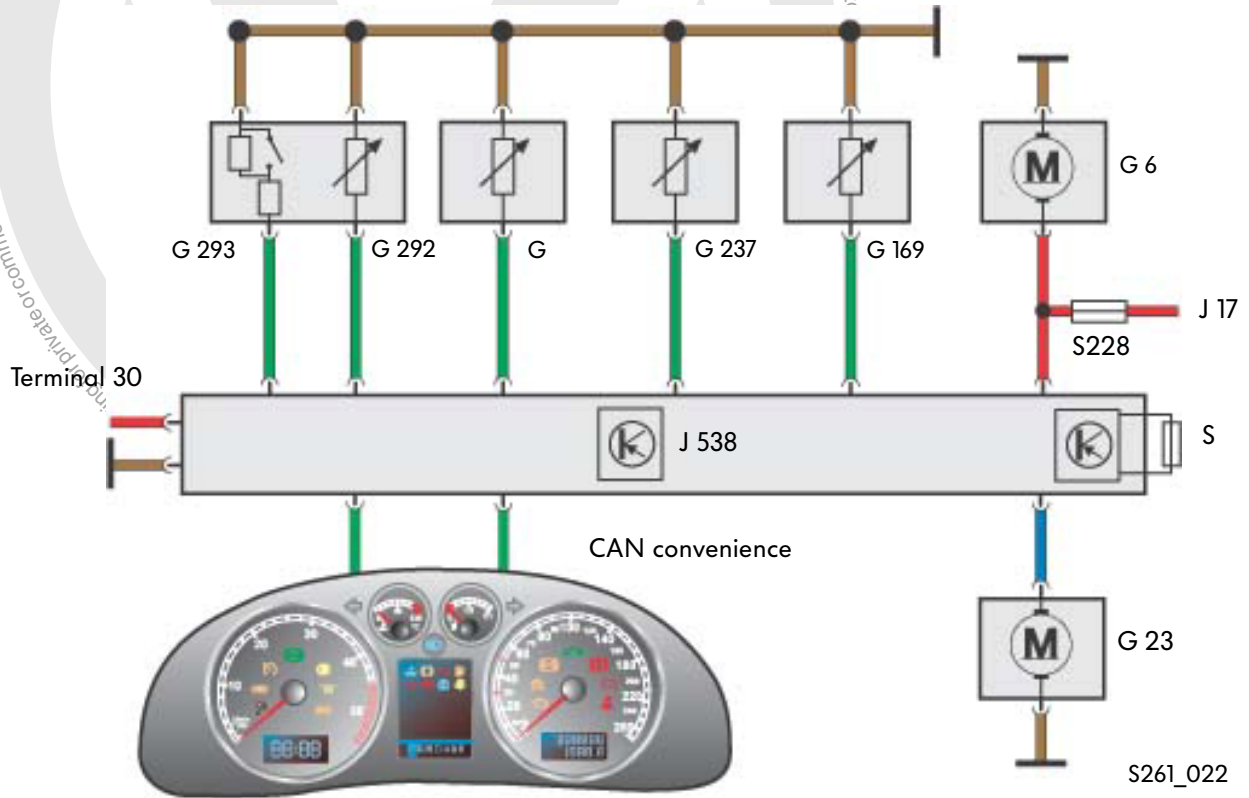

- G 293 - Fuel level sender, additional fuel tank empty
- G 292 - fuel level sender, additional fuel tank
- G - sender for fuel level indicator
- G 237 - sender 3 for fuel level indicator
- G 169 - sender 2 for fuel level indicator

- G 6 - fuel pump (pre-supply pump)
- J 17 - fuel pump relay
- G 23 - fuel pump
- J538 - control unit for fuel pumps
- S228 - fuse in the fuse box
- S - fuse in the control unit

The fuel level indicator

Due to the different heights of the fuel tanks, four fuel level senders are required to calculate the remaining fuel amount correctly. The signals from all the senders are evaluated in the fuel pump control unit. The resulting signal runs via the CAN convenience bus to the dash panel insert and is used to control the fuel level indicator. The fuel pump control unit is self-diagnosable by address word 58.

Control unit for fuel pump J538

The fuel pump control unit is located in the spare-wheel well embedded in plastic. It is connected to the CAN convenience bus. The control unit is therefore connected to the dash panel insert. It has the following tasks:

- Evaluating signals from the four fuel level senders
- Controlling the fuel level indicators
- Controlling the fuel pump G 23 in the additional fuel tank
- Controlling the tank warning lamp

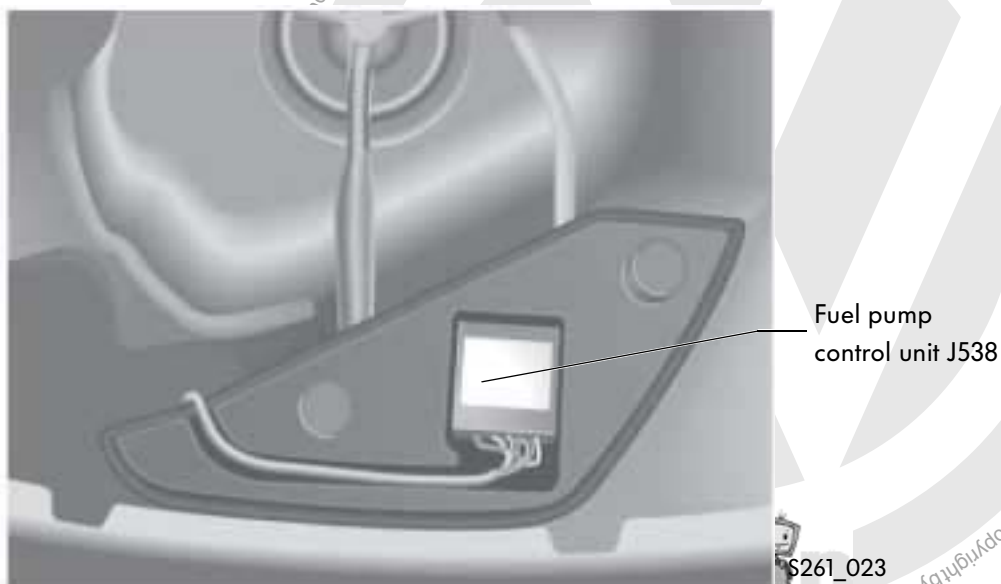

Power transmission

Gearbox

The 6-speed manual gearbox 01E, four-wheel drive

The 6-speed manual gearbox 01E from the Passat 2001 is also fitted to the Passat W8. As the Passat W8 is supplied with 4Motion four-wheel drive as standard, a Torsen differential is integrated in the gearbox to distribute the engine torque to all four wheels. The gearbox casing is adapted to fit the W8 engine.



S261_024

The 5-speed automatic gearbox 01V

The gearbox was adapted to fit the W8 engine, i.e. the casing and gear ratios, as well as the clutches and brakes.

A Torsen differential is also integrated in the automatic gearbox to distribute the engine torque to all four wheels.

The five-speed automatic gearbox 01V has:

- a dynamic shift programme (DSP)
- Tiptronic
- a torque converter with torque converter lockup clutch



S261_025

The four-wheel drive 4Motion

The main function of the four-wheel drive is to compensate the drive forces between the front and rear axles as a factor of positive engagement.

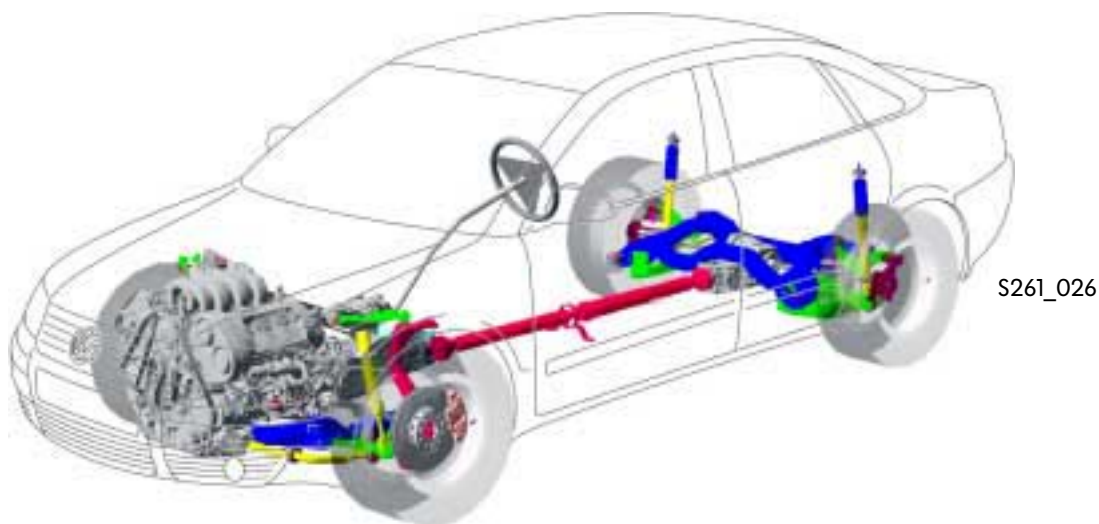

S261_026



The Torsen differential detects wheel slip in one axle and distributes the drive power to the wheels of an axle with better wheel grip.

The Torsen differential permits limited differences in speed between the front and rear axles and therefore allows ABS control processes. It operates automatically and reacts independent of the driver.

The Torsen differential (Torsen = torque sensing)

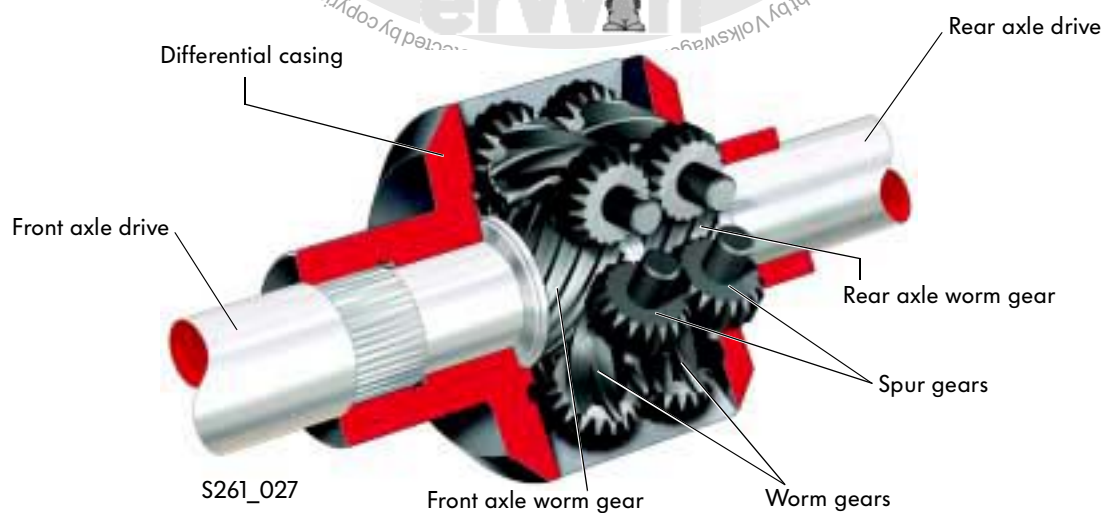

S261_027

Running gear

The four-link front suspension

The design of the front axle on the Passat W8 is identical to the Passat model year 2001. The following components have been modified to cope with the higher weight and the resulting axle loads:

- the wheel bearing housing
- the wheel bearings
- the wheel hub, and
- the tubular subframe

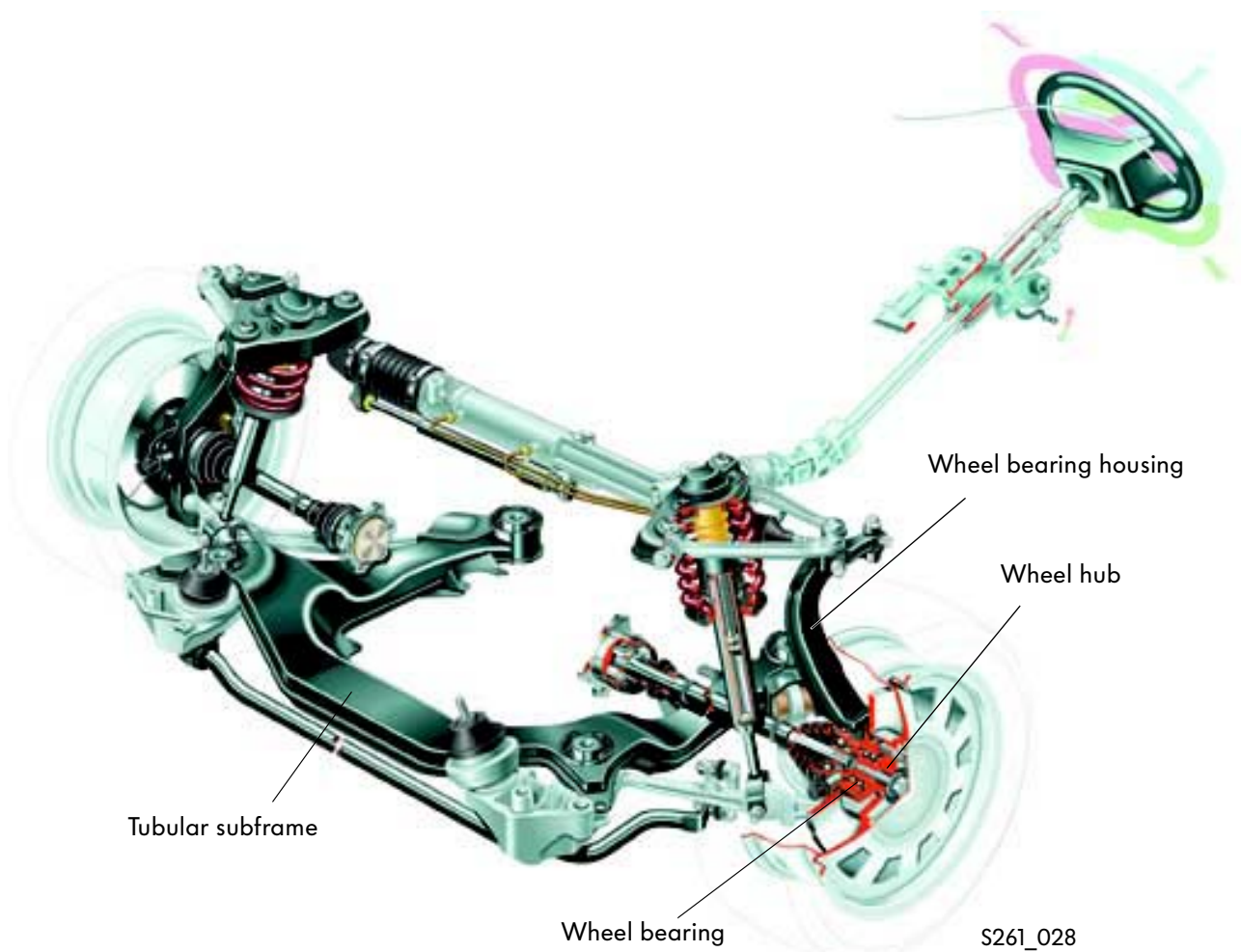

Steering

The steering remains unchanged compared with the Passat 2001:

- steering column adjustable in height and reach
- hydraulic power steering gear

The double wishbone rear suspension

The proven double wishbone rear suspension with closed tubular subframe is fitted to the Passat W8.

What is new are the wheel bearing housings with a modified attachment to the track rods.

Information is not permitted unless authorised by Volkswagen AG. Volkswagen AG does not guarantee or accept any liability with respect to the correctness of information.

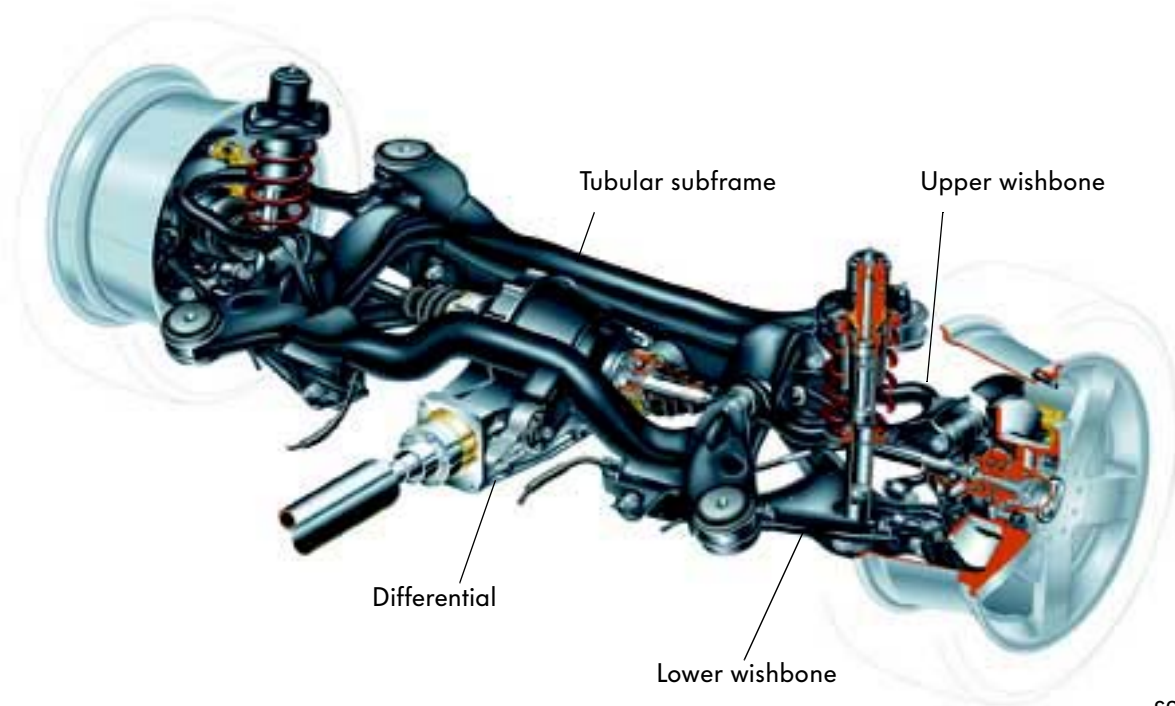

S261_029

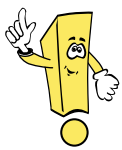

New wheel bearing housing:

- Wheel bearing housing made of aluminium
- Track rods guided at both ends
- Larger track width

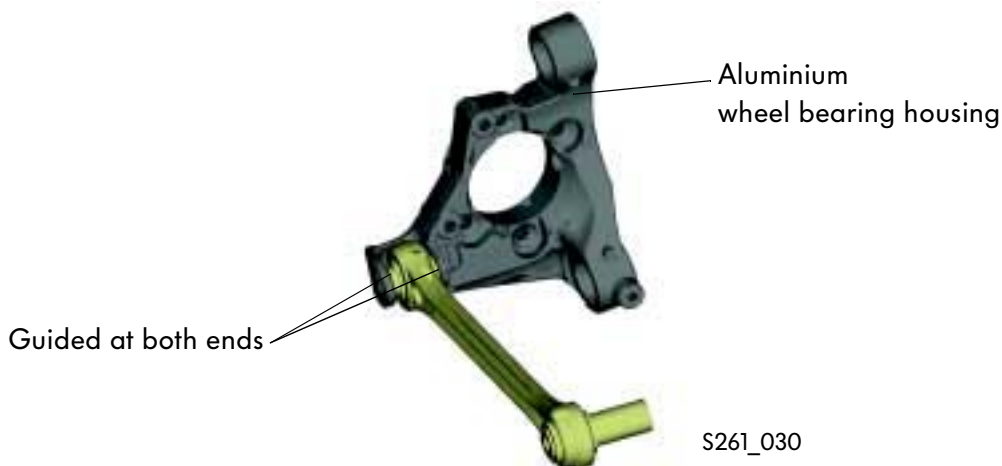

S261_030

Running gear

The brake system

The Passat W8 currently has the most powerful brake system of all Volkswagen car models.

Despite high engine performance, it achieves excellent deceleration rates.

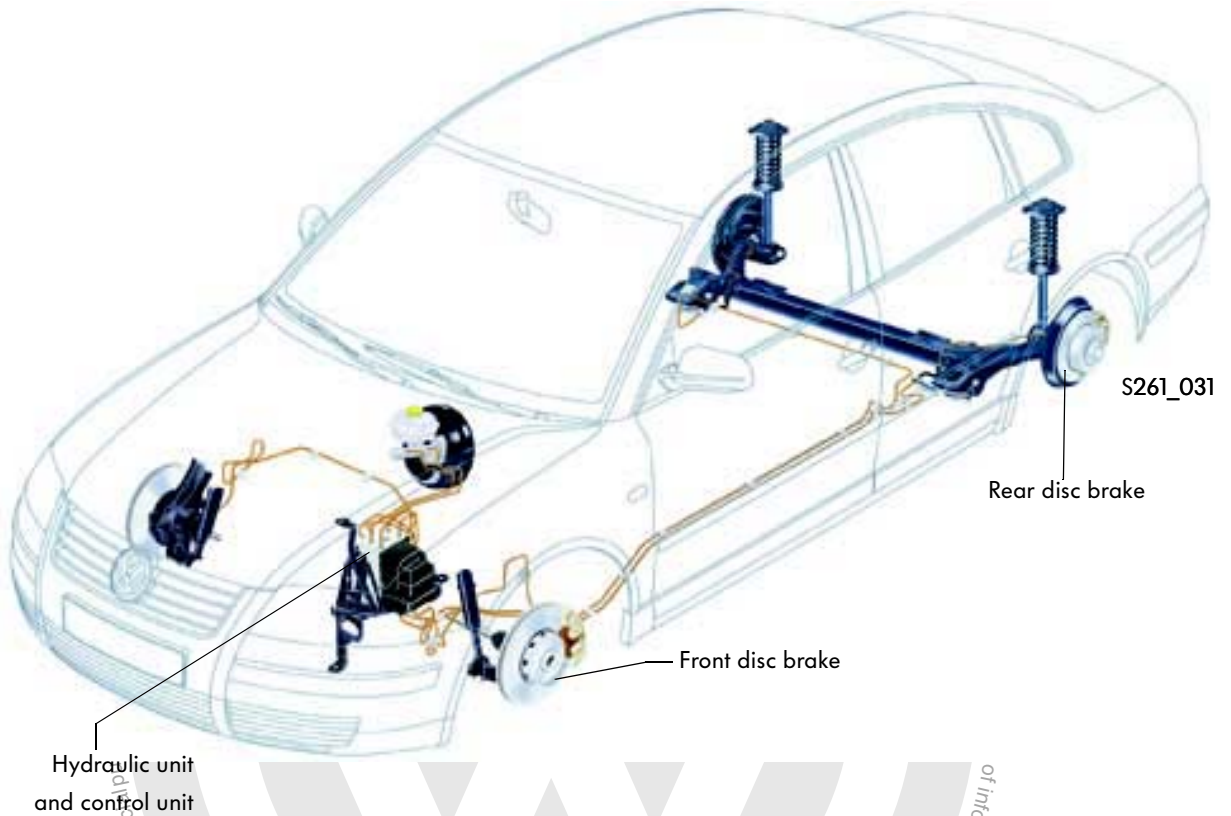

Front disc brake

Disc diameter x thickness

- 334 mm x 32 mm
- 321 mm x 30 mm

Rear disc brake

Disc diameter x thickness

- 269 mm x 22 mm



The hydraulic unit and ABS control unit

The Passat W8 receives the Bosch 5.7 ABS system with ESP (Electronic Stability Programme) and the hydraulic brake assistant system (BAS). Special features of the Bosch 5.7 ABS system are:

- The hydraulic unit and the control unit form a single unit
- The ABS two-stage recirculating pump V39 replaces the hydraulic pump for electronic dynamics control V156.
- The pressure sensor G294 is contained in the hydraulic unit.

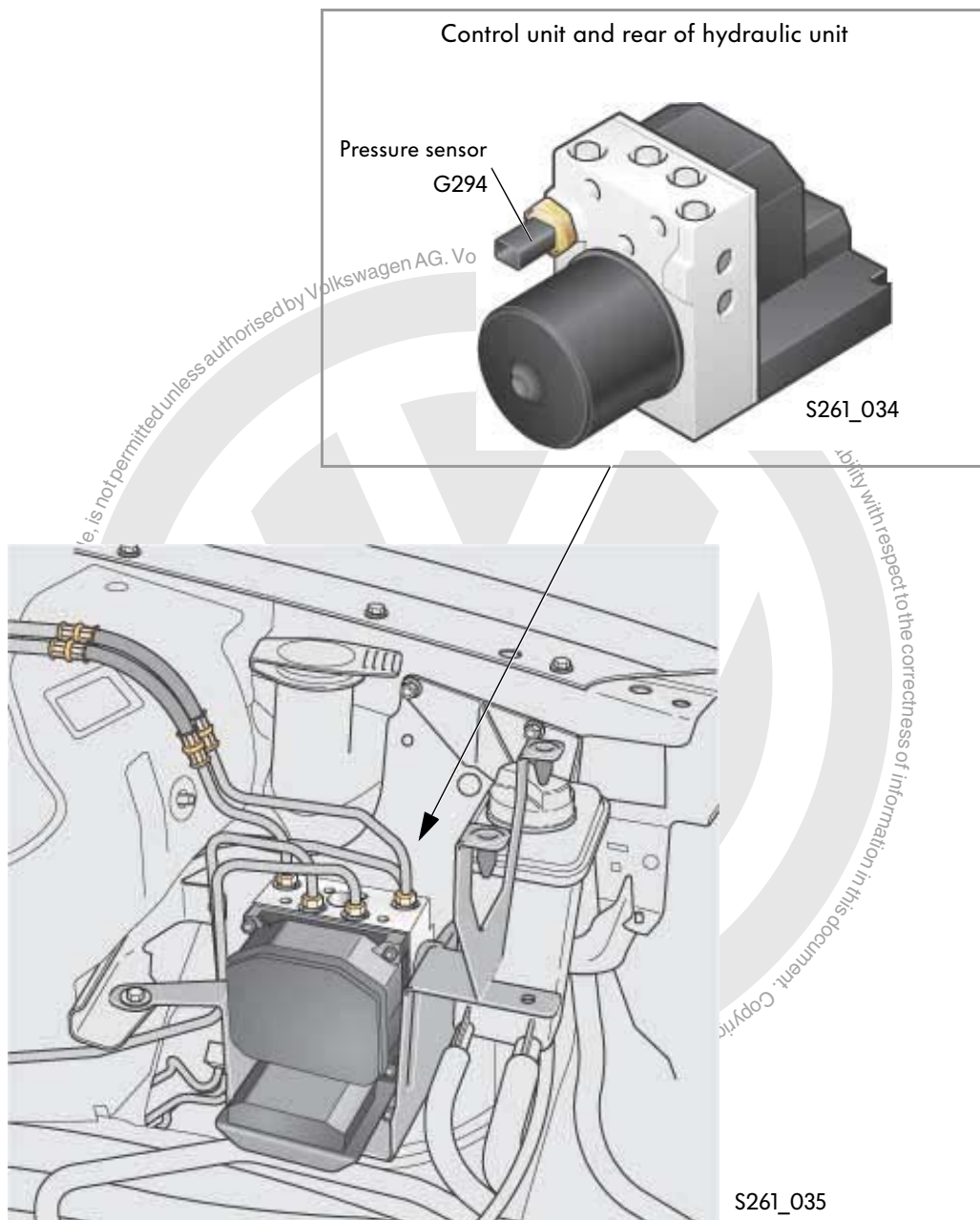

Running gear

The ABS two-stage recirculating pump V39

is integrated in the Bosch 5.7 ABS system. When the ESP intervenes, it supplies the required preliminary pressure in the brake lines. The pistons of the two-stage recirculating pump operate at both sides.

While pressure is building up in working chamber 1, the piston in working chamber 2 sucks brake fluid in. This creates a suction process with every piston stroke.

Suction process in working chamber 2

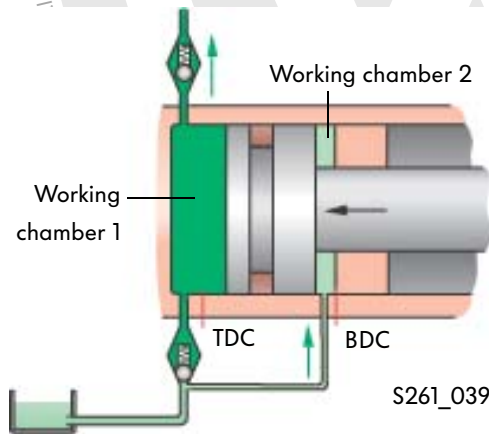

Suction process in working chamber 1

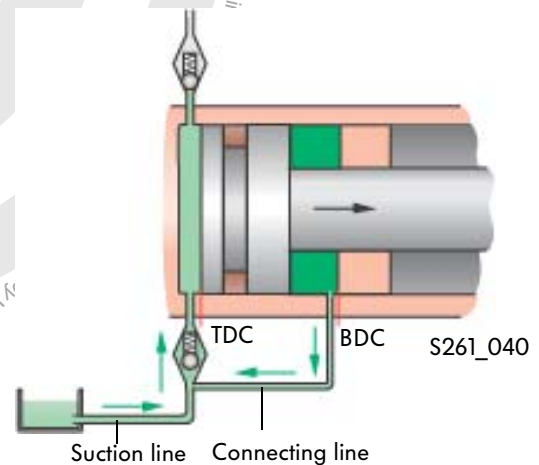

A suction process takes place with every piston stroke.

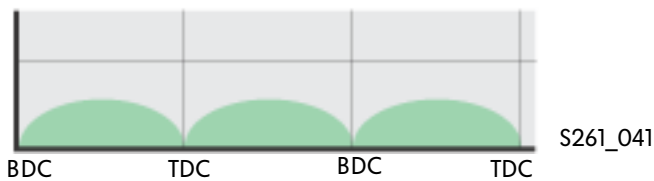

As the full suction volume is pumped almost continuously, the maximum suction flow is much smaller than on single-stage recirculating pumps.

This reduces the pressure in the suction line and prevents cavitation. It ensures rapid pressure build-up, even at extremely low temperatures.



Cavitation is the formation of vapour bubbles in flowing liquids. The associated pressure surges could cause material damage.

The hydraulic brake assistant system (BAS)

is integrated in the ABS control unit. Accident research studies have shown that the majority of drivers do not press hard enough on the brakes in critical situations. This means that pressure build-up is insufficient to reach maximum vehicle deceleration.

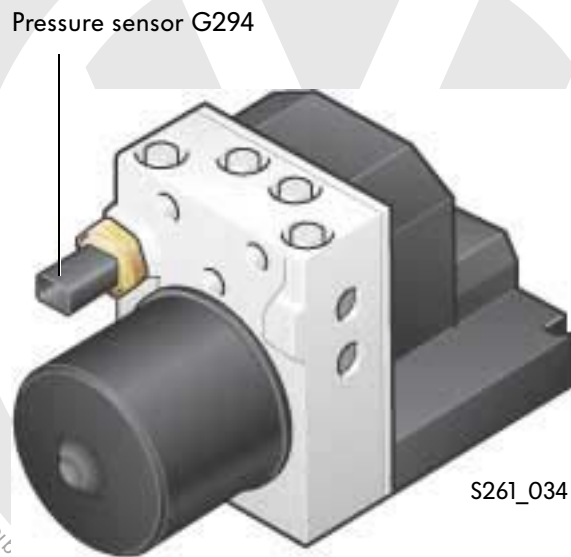

Pressure rise in brake system

The pressure sensor G294 detects the pressure rise in the brake system. The control unit recognises an emergency braking action by the rapid rise in brake pressure within a specific period of time. After it detects the emergency situation, it increases the brake pressure within the ABS control range. This shortens the stopping distance and the car comes to a standstill faster.

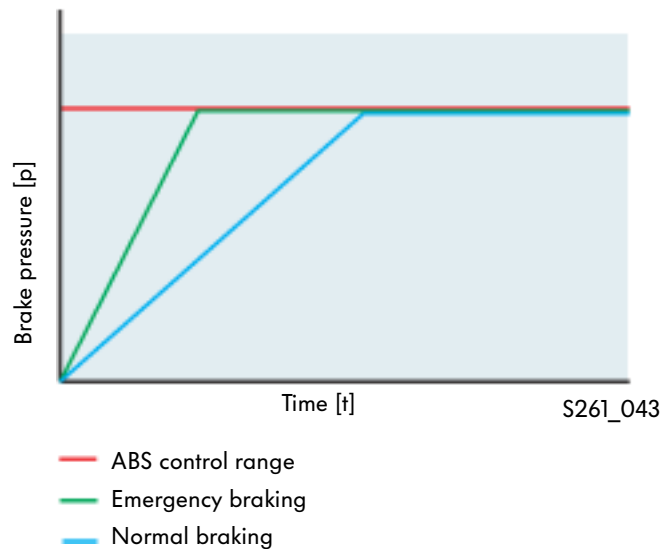

You will find explanations on the design and function of the hydraulic brake assistant system (BAS) in Self-Study Programme No. 264.

Vehicle electrical system

The vehicle electrical system

The electrical system on the Passat W8 has a similar design as on the Passat model year 2001. The following pages will describe modifications to components and functions compares with the Passat model year 2001. All components not described here are identical with the Passat 2001.

Airbag control unit
(gearbox tunnel)



Connector station
A-pillar, right



Radio with dynamic
navigation RNS-D



Automatic gearbox
control unit
(right footwell)



Electronics box in
plenum chamber

- Engine control unit
- Relay station
- Connector station
- Fuses

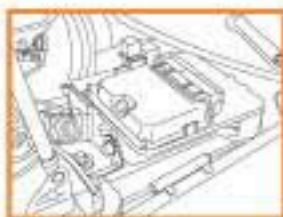

Connector front end



Central electrics

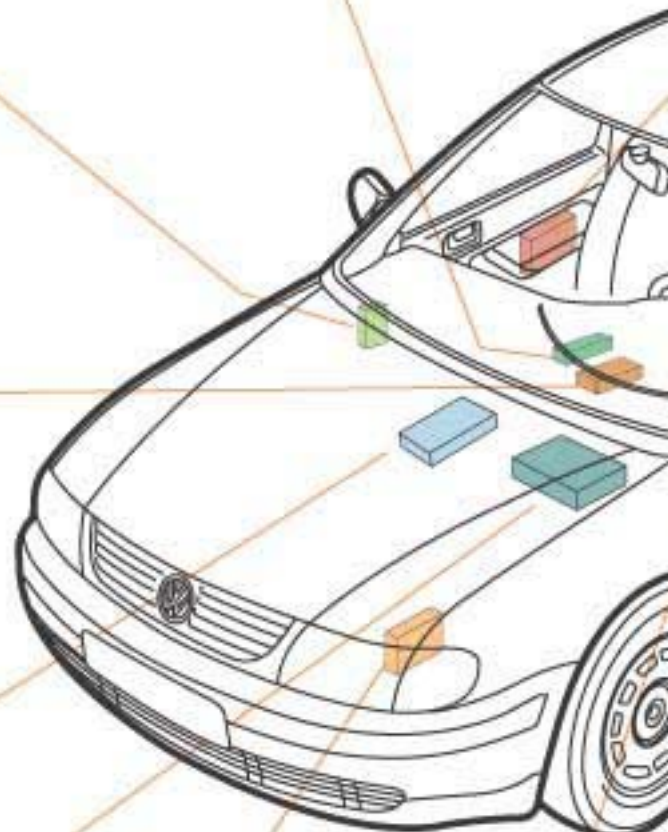

For private or commercial purposes, in part or whole, is not permitted.

Window lifter motor with integrated door control unit

Control unit for parking aid (luggage compartment, right)

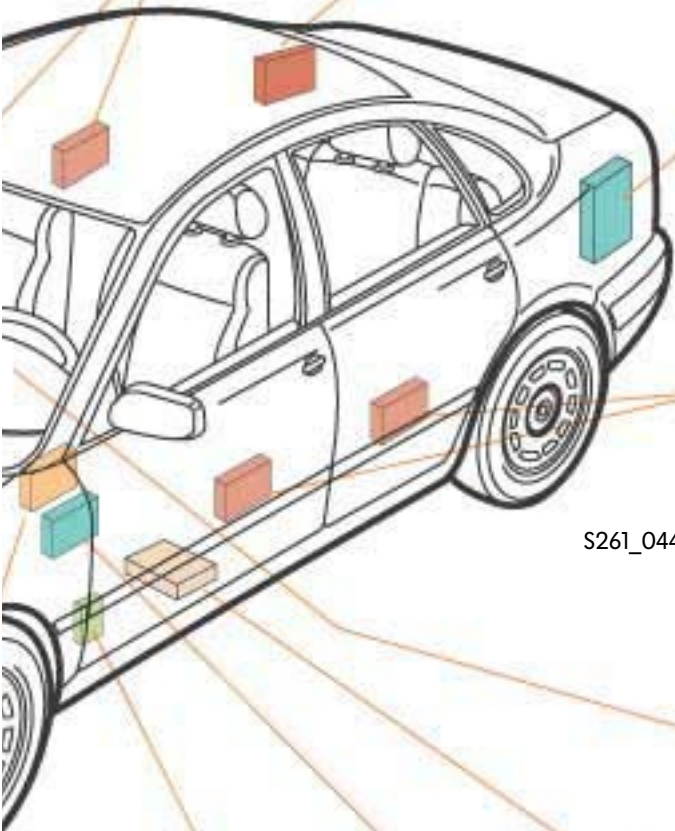

TV tuner
CD changer
DSP



Window lifter motor with integrated door control unit

S261_044

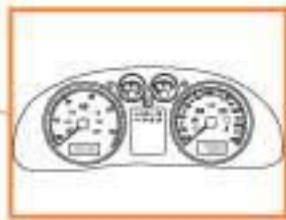

Dash panel insert with immobiliser control unit and diagnostic interface gateway



Connector station A-pillar, left



Fuse box, dash panel, left

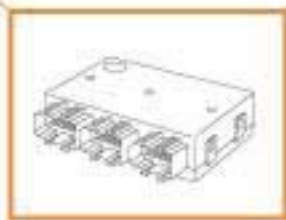

Convenience control unit in footwell, left

respect to the correctness of Informa



Vehicle electrical system

The gas discharge headlight (GDH) with bi-xenon light

The Passat W8 is only fitted with the bi-xenon headlight system. The improved light output of the system increases active driving safety as the driver can detect danger earlier.

The bi-xenon headlight module produces the dipped beam and the main beam from a single gas discharge lamp.

The main beam is intensified by a H7 lamp. This lamp also bridges the time until the gas discharge lamp reaches its full light intensity. The H7 lamp is also used for the headlight flasher function.

Due to the gas discharge headlights, all bi-xenon cars are equipped with automatic and dynamic headlight range control (refer to SSP 251).



H7 lamp
(additional main beam)

Indicator lights

Gas discharge lamp
(dipped and main beams)

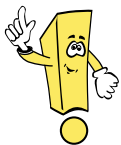

When driving in LHD countries, the two headlights can be changed over from asymmetric to symmetric dipped beam.

Please refer to the information in the Workshop Manual.



The design of a bi-xenon headlight module is described in Self-Study Programme No. 251.

Convenience and safety electronics

Passat W8 with Internet access

Networking a vehicle is no longer limited to the car's immediate surroundings but goes far beyond this. The in-car communications equipment now provides access to the world-wide data network, the Internet.

The Internet interface is a device which is linked to the radio navigation system via the CAN bus. Communication with the Internet (outside world) is by means of a mobile radio aerial (GSM antenna) which complies with the present-day standard.

Internet interface with GSM antenna and connected laptop



S261_046



Internet access allows retrieval of specially processed driver-orientated information over the radio navigation monitor, e.g. traffic information, trip/route planning, logistics support for hire cars and breakdown or emergency call systems etc.

If a laptop is connected, the user can surf freely on the Internet and send e-mails.

Convenience and safety electronics

The convenience system

Interior monitor and anti-theft alarm system

The Passat W8 anti-theft alarm system is equipped with a new function and a new alarm horn. The new alarm horn, designated the H12, is mounted in the plenum chamber. It has a separate power supply.

Two lithium batteries integrated in the horn ensure that the horn operates independent of the car battery. The batteries have a life of approx. 5 to 7 years. If the batteries are discharged or defective, the horn must be replaced.

Fitting location

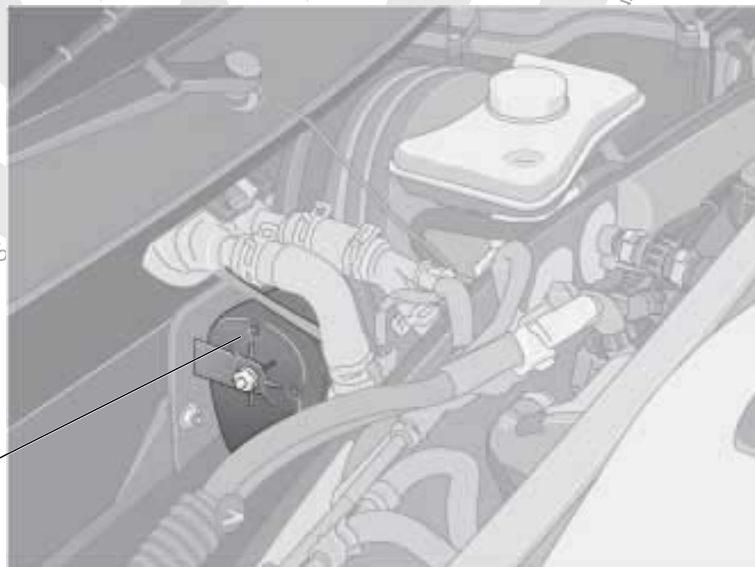

Alarm horn H12

S261_047

Function

The horn communicates bidirectionally with the convenience system control unit J393. After the car is locked, the horn is armed via the control unit. This means the vehicle power supply and the horn signalling line are monitored in addition to the other functions of the anti-theft alarm system.

When the car is unlocked by the radio-wave remote control key, the anti-theft alarm system is deactivated. If the car is opened mechanically via the lock cylinder of the door, the ignition must be turned on within 15 seconds. If this does not happen, the anti-theft alarm system is activated.

Function diagram of signal horn for anti-theft alarm system

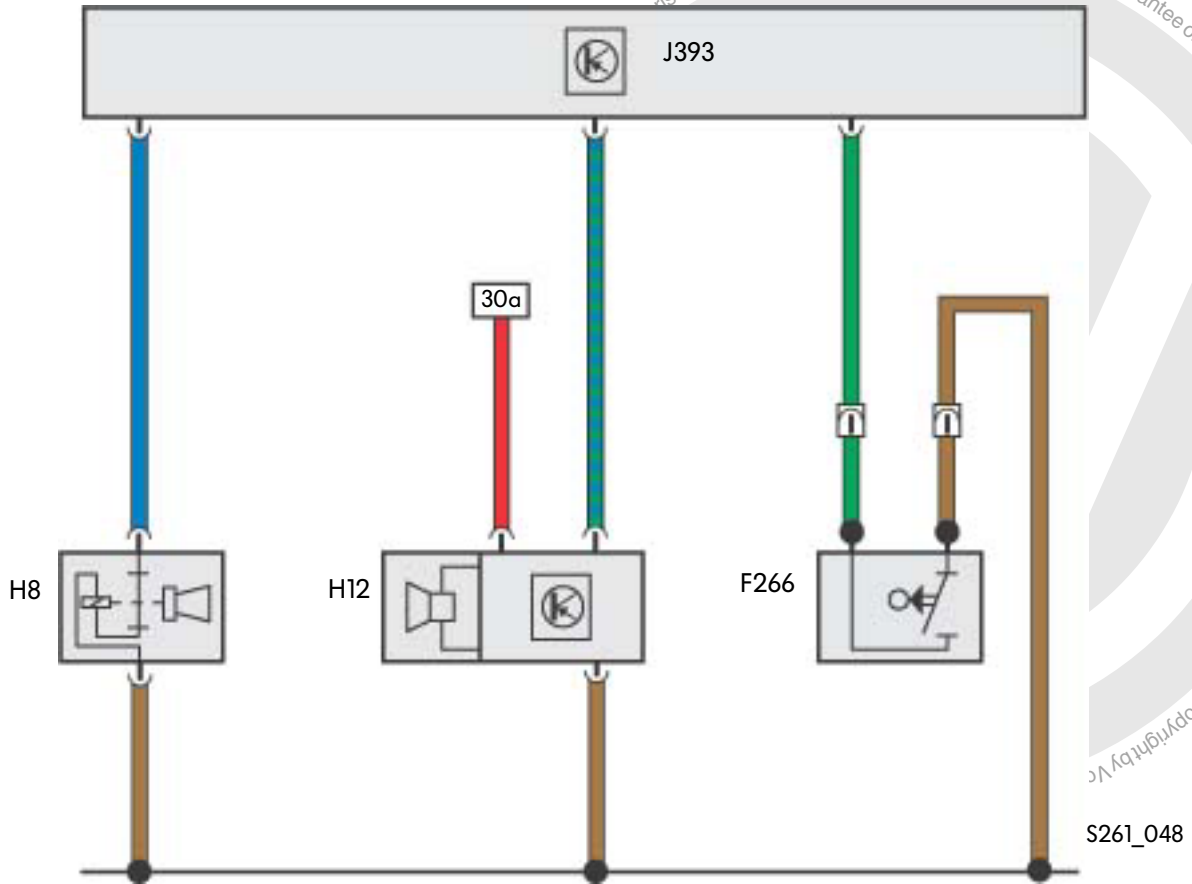

- F266 -contact switch for bonnet, in lock part
- H8 -signal horn for anti-theft alarm system
- H12 -alarm horn
- J393 -central control unit for convenience system
- 30a -positive terminal



The anti-theft alarm system has self-diagnostic capability. You will find the self-diagnosis in the vehicle diagnostic testing and information system (VAS 5051) in the guided fault-finding under Body - Body Repairs and the address word Convenience System. Please always use the latest version of the Workshop Manual in the electronic Service Information System (ELSA) when fault-finding.

Convenience and safety electronics

The "Delta" radio system

supplements the current radio generation. At first glance the differences to the other units are its larger size and a redesigned user interface.

Other new features compared to the current radio systems are:

- integrated CD player
- two FM/AM tuners
- improved TIM function (Traffic Information Memory)
- aerial sockets for aerial selection
- compact connectors with central locking
- CAN bus convenience networking

The important new button names and functions are summarised below.

The user interface



Audio CD entry

TIM function

There are two separate adjustable 2 hour timers to program the time for starting to record radio traffic information.

Example: The starting time for the trip to work and back in the evening can be saved separately for 2 hours.



S261_049

MIX button

In CD mode, tracks are played in random sequence.

Rotary/push button for SCAN/TUNE

SCAN

Press in radio mode to search for a station or in CD mode to briefly play the start of the track.

TUNE

Rotate to tune the FM/AM station manually or to select the previous/next track in CD mode.

SEEK/TRACK button

SEEK

In radio mode, hit to start station search (SEEK) in AM band. In FM or TP band, browse through storage list.

TRACK

Hit briefly to skip forward or backward through CD tracks. Press longer to start audible fast forward or fast reverse of a track.

DSP button

Selects the menu for basic tone settings using **Digital Sound Processor (DSP)**



Convenience and safety electronics

Radio rear panel

The rear panel of the radio contains the aerial sockets and the central connector.

The aerial sockets

Aerial input for FM/AM signal from control unit for aerial selection

Output to control unit for aerial selection



The aerial sockets

To avoid plugging the aerial connectors in the wrong socket the connector housings have a plug coding and different colours. This means that a connector will only fit in its associated aerial socket. The connector engages when it is plugged into the socket. To release the connector, operate the unlocking mechanism on the socket.

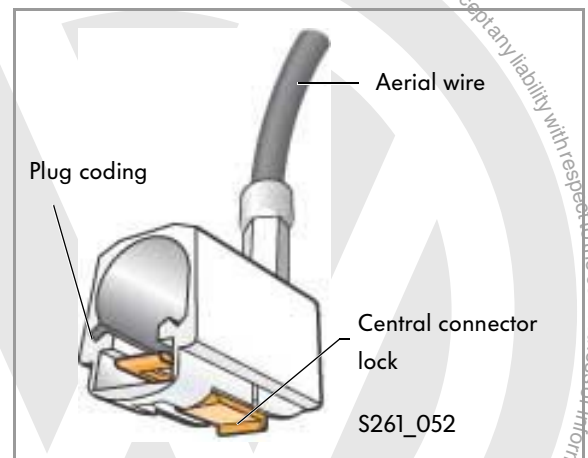

Central connector with central locking

The central modular connector groups all the individual connectors, such as connectors for the CD changer or loudspeakers. The individual connectors can be plugged separately in the central connector housing. Locking and unlocking is by means of a central locking mechanism.



Tuner

The radio has two integrated FM/AM tuners.

One of the tuners is only adjusted for receiving frequencies from FM/AM stations. The other tuner is used for setting the frequencies to receive TP/FM traffic radio stations. This allows selection of traffic radio messages from a TP station irrespective of the FM station setting.

Example:

You are listening to an FM station, e.g. NDR 2, which broadcasts supraregional traffic radio messages. To receive current regional traffic radio messages, select a TP station e.g. ANTENNE by pressing the TP button. When the selected TP station broadcasts traffic radio messages, they will cut into the current programme of the FM station the driver is listening to. This also applies when the driver is listening to an AM/MW station or the radio is in CD mode.



If the "TP tuner" is not being used to receive TP stations, e.g. TP button OFF, it supports the "FM tuner". It checks the alternative frequencies of an FM station setting to find a better reception frequency.

This makes checking the alternative frequencies faster and avoids short-term mute pauses caused by checking.



Convenience and safety electronics

CAN bus networking

To control functions and processes, the radio control unit and the dash panel insert exchange the following information over the CAN bus.



- NO contact
- Terminal 15
- Road speed signal (GALA)
- Display lighting
- Self-diagnosis processing
- Radio convenience coding
- Control signals from the multifunction steering wheel
- Vehicle identification number

S261_055



For further Information on the subject of the radio system, refer to the following Self-Study Programmes:

- SSP 147 Radio Systems '94
- SSP 199 The Radio Navigation System
- SSP 201 The Lupo

For more details on how to operate the radio system, please refer to the related operating manual.



The radio aerial system

FM/AM reception of the radio system on the Passat W8 has been considerably improved. This was achieved by fitting four independent FM/AM aerials (see SSP 147).

If reception is poor, the aerial control unit switches to another aerial with a stronger signal. The aerials are in different locations on the saloon and on the estate.

Location of aerials on the saloon

On the saloon, the AM medium wave aerial is above the rear window heater. The four FM aerials are integrated in the rear window heater.

Suppressors in the supply wires of the rear window heater prevent the radio signals received from flowing via the positive and negative terminals of the rear window heater.

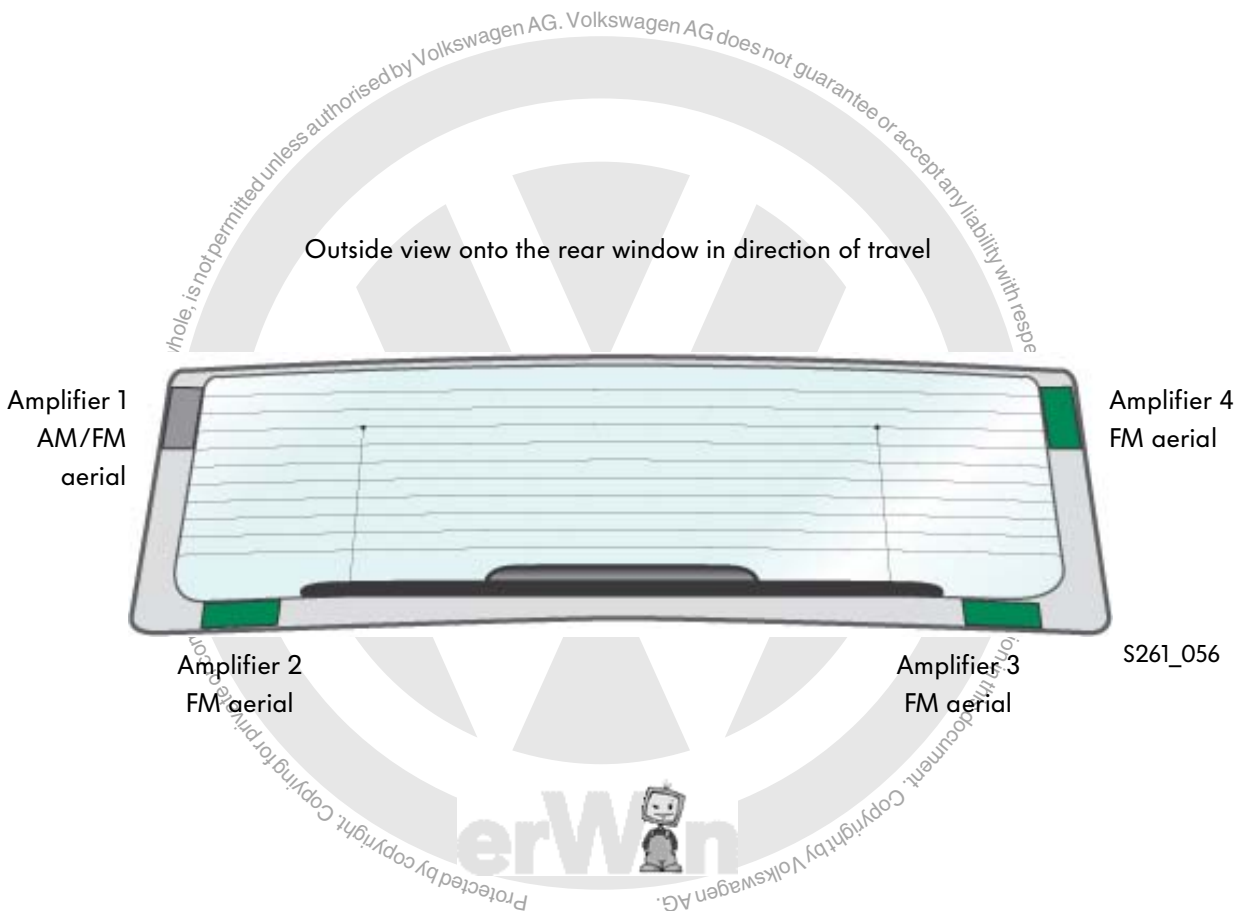

Convenience and safety electronics

Location of aerials on the estate

On the estate, the aerials are located in the rear side windows. Viewed in the direction of travel there is a combined AM/FM aerial on the left-hand side and two FM aerials on the right-hand side.

As on the saloon, each FM aerial is allocated to an aerial amplifier. Even on the estate, the amplifiers should not be wrongly allocated. As the aerials on the estate do not use the rear window heater, no suppressors are required.

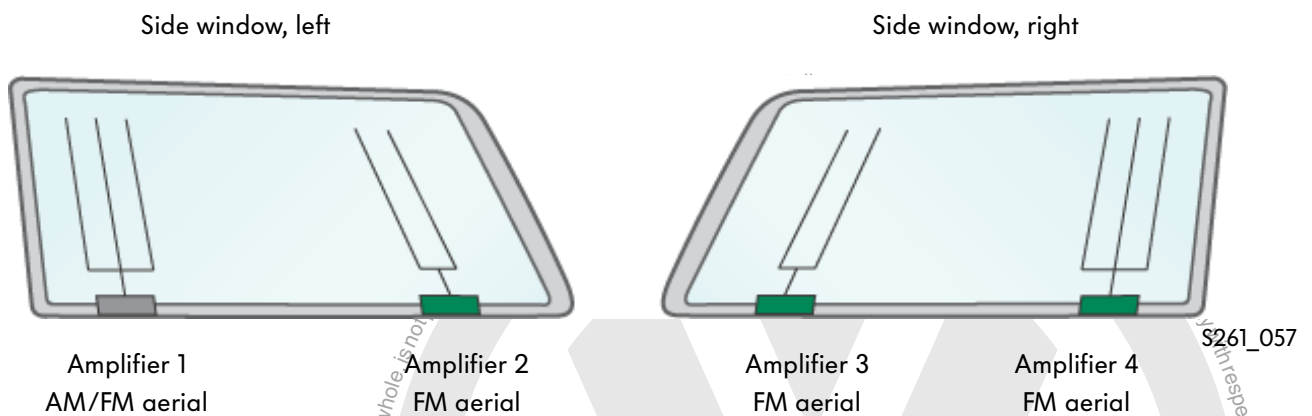

The aerial amplifiers

Each FM aerial is allocated to an aerial amplifier. They are precisely matched to their fitting location and must not be allocated wrongly. Depending on country-specific radio frequencies, a number of antenna amplifier variants can be fitted.



Function

The radio signal received from one of the four aerials runs via an aerial switch circuit inside the aerial selector control unit to the tuner. In the tuner, the signal quality is checked and the result is fed back to the control unit via an aerial output line.

If the selected signal is too weak for tuner reception, the aerial switch switches automatically to the next of the four aerials. This process is repeated until an aerial is found with good reception. Switchover is so fast that the car occupants do not notice it.

Function diagram for aerial system (example: Passat estate)

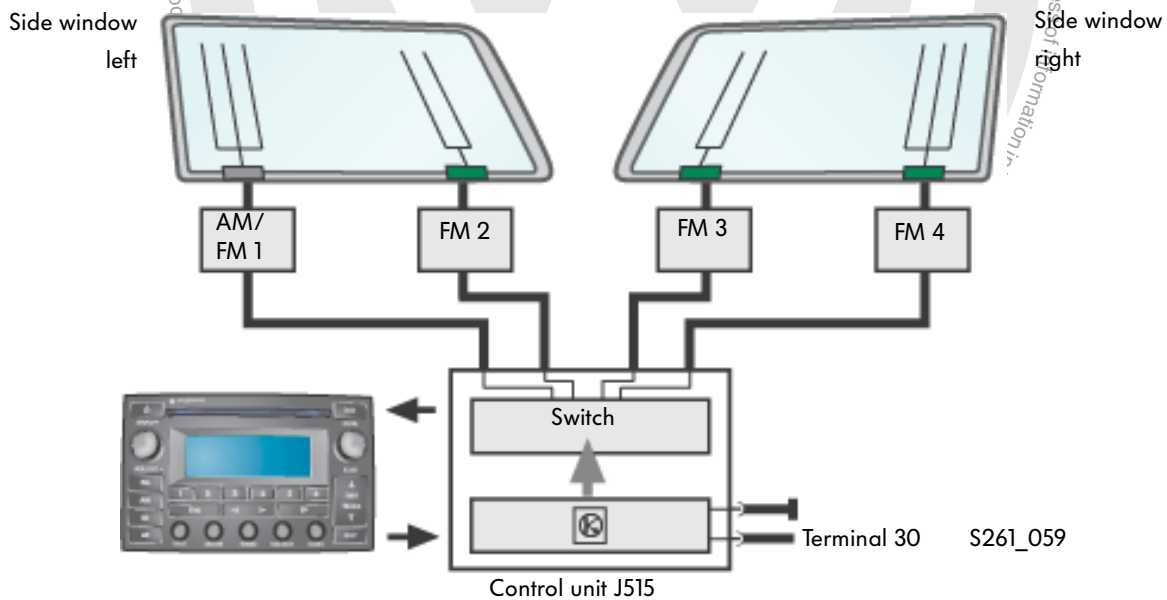

The control unit for aerial selection J 515

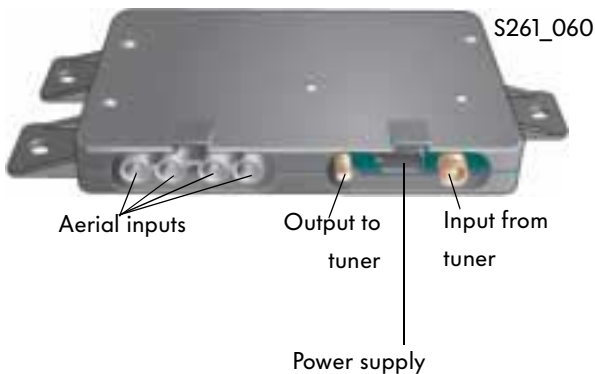

is located under the rear shelf on the saloon or on the rear left wheel housing in the luggage compartment of the estate. Its function is to switch over to the aerial with the best reception.



This aerial system is currently offered with the "Delta" radio system.



Heating, air conditioning system

Heating and air conditioning system

The CLIMAtronic with fully automatic control is offered on the Passat W8.

A combination of the following components forms the main difference with the previous fully automatic air conditioning system fitted to the Passat:

- Sender for evaporator outlet temperature G263
- Externally regulated compressor with regulating valve N280 and integrated overload protection,

The interaction between these two components in conjunction with the entire CLIMAtronic results in a needs-orientated temperature control.

It permits a reduction in power consumption and helps to save fuel consumption.

Distribution box and housing for evaporator

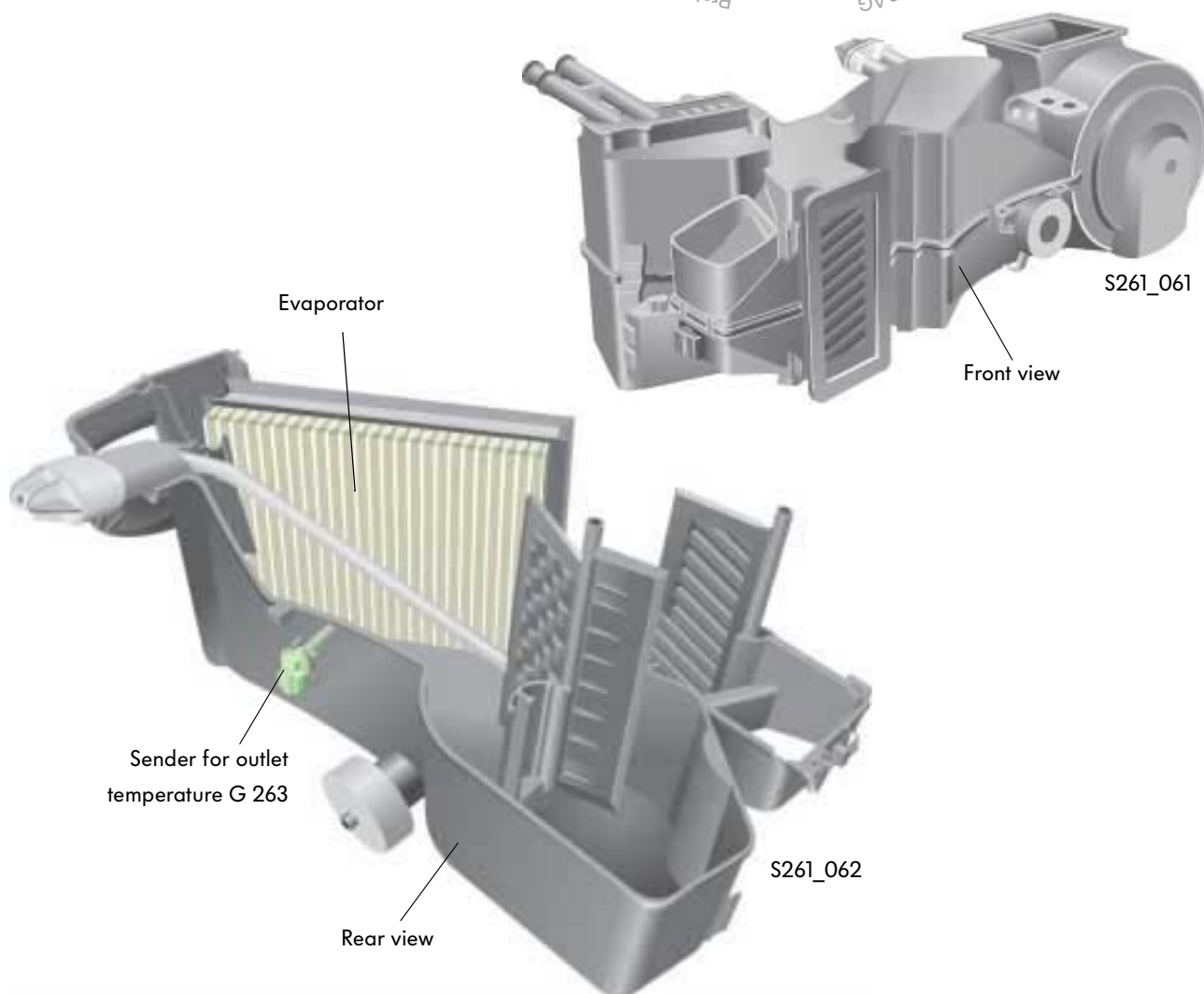

The externally regulated compressor

The compressor basically works on the principle of the swash plate. The technical features of the externally regulated compressor are:

- One-sided swash plate compressor with 7 lifting pistons
- Variable lifting volume to match the refrigerating capacity demand
- Hollow pistons
- Belt pulley drive with no magnetic clutch and integrated overload protection
- External regulating valve N280 to regulate the pressure conditions in the compressor

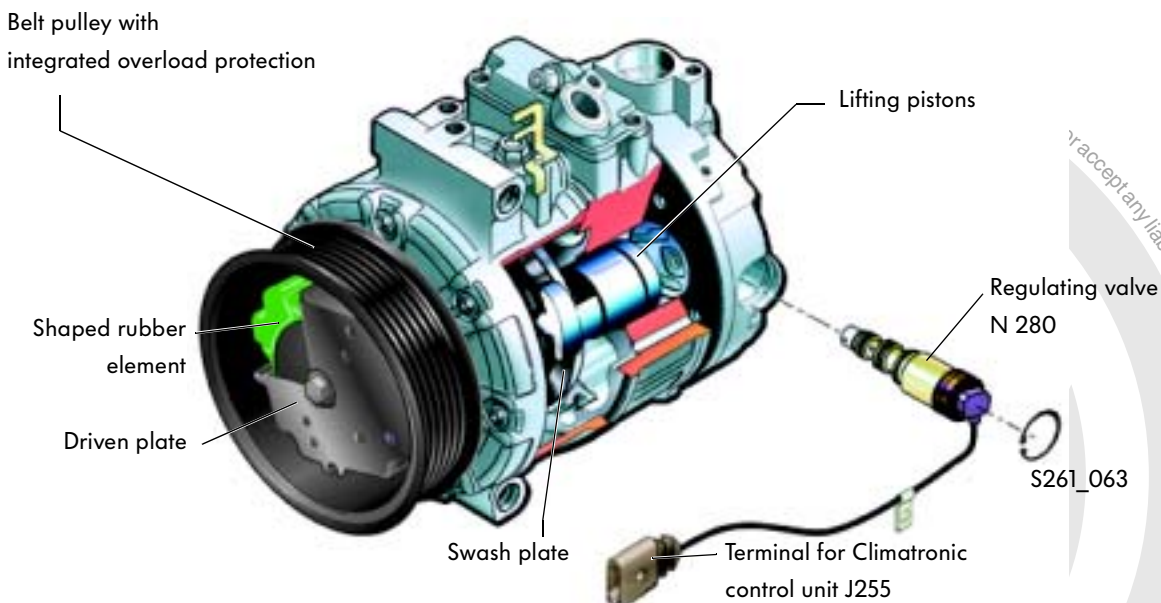

Function

The CLIMAtronic control unit J255 variably controls the regulating valve on the compressor N 280. Depending on the parameters, input desired temperature, ambient and interior temperature, evaporator temperature and refrigerant pressure in refrigerant circuit, the pressure conditions on the intake pressure side is changed by a control voltage.

The inclined position of the swash plate changes. This determines the stroke volume and therefore the refrigeration performance generated.

The compressor continues to run via the ribbed V-belt drive even when the air conditioning system is off. The delivery volume of the refrigerant is regulated to under 2%.



Heating, air conditioning system

The overload protection

The V-belt pulley and the driven plate are positively joined by a shaped rubber element.

When the compressor is operational, the two plates rotate in the same ratio to each other.

Compressor in function

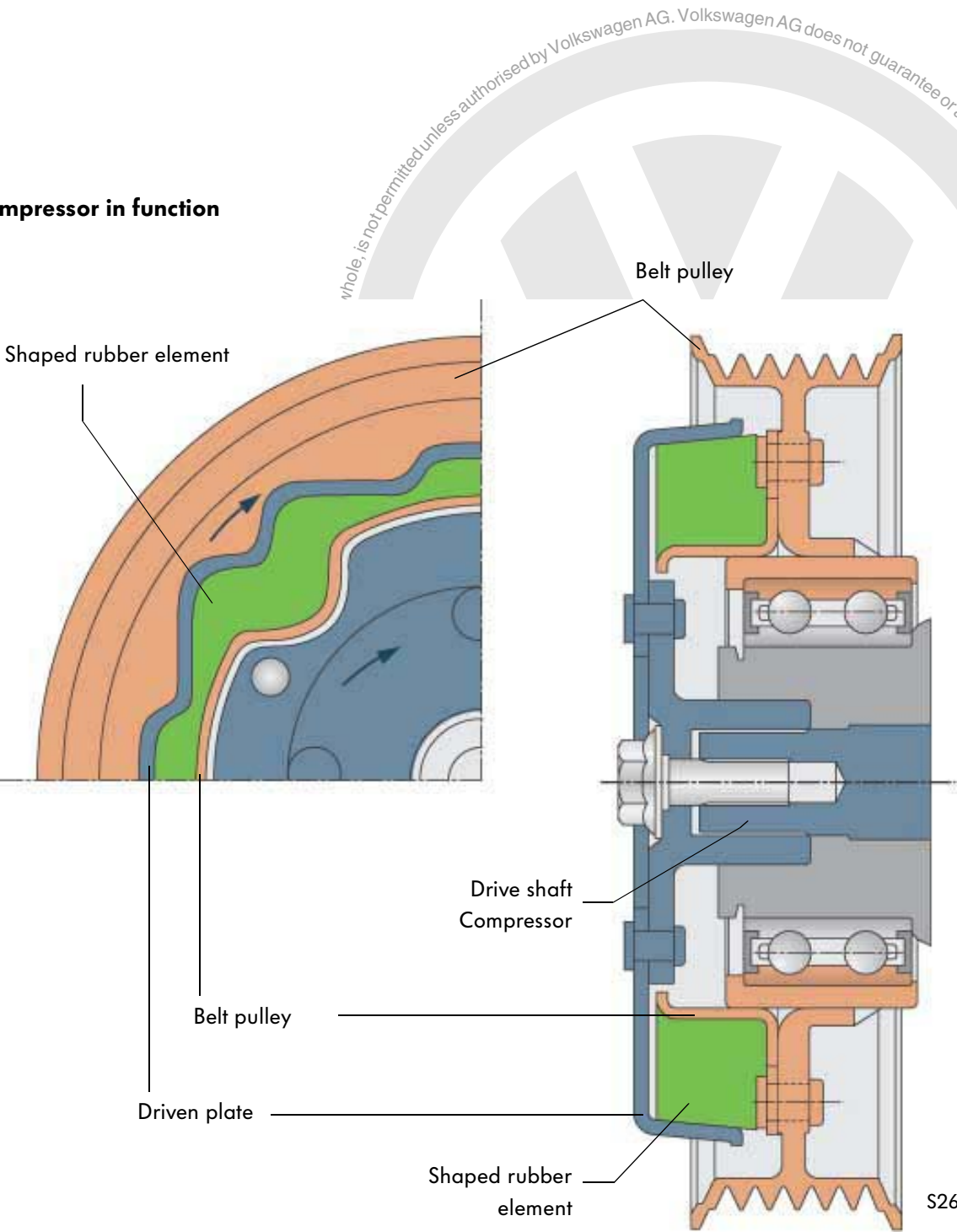

If the compressor is damaged internally, it may cause the drive shaft to block. The driven plate will also stop.

This drastically increases the transfer forces between the belt pulley and the driven plate. The shaped rubber element is pressed by the belt pulley in the direction of rotation onto the blocked driven plate.

The projecting shapes on the rubber element shear off and the joint between the belt pulley and the driven plate is separated. The belt pulley continues to rotate unhindered. This prevents any damage to the ribbed V-belt and excludes engine damage.

Compressor blocked

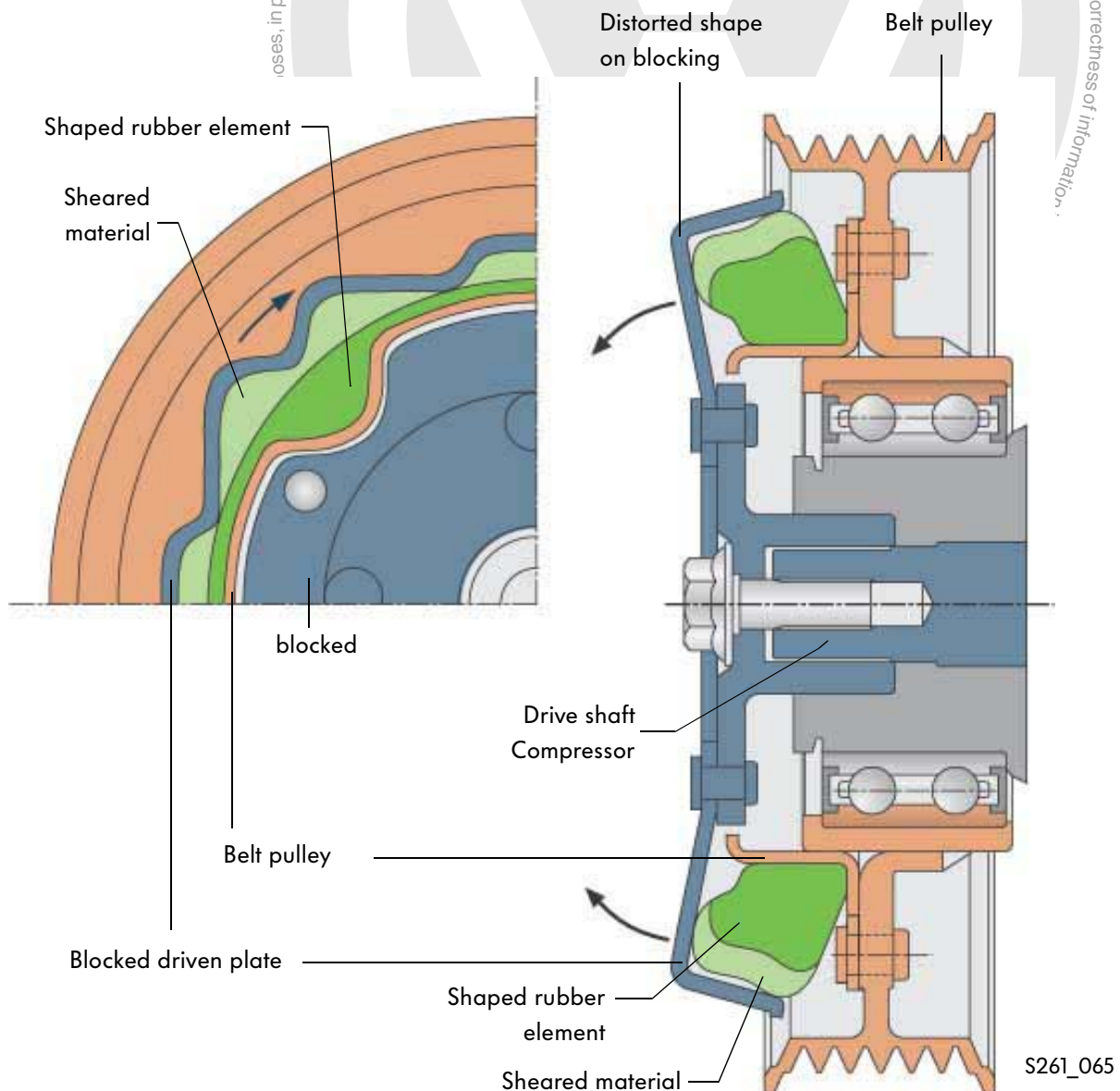

Heating, air conditioning system

The evaporator control circuit

When the CLIMATronic is ON and the driver enters the desired temperature, the refrigerant demand is determined and changed by a number of different influences.

The components described below form a control circuit for regulating the desired temperature.

The compressor regulating valve N280

The external regulating valve forms an interface between the suction and high pressure sides of the compressor. It balances out the pressures applied.

For example, if the cooling output is increased, the regulating valve is controlled by the CLIMATronic control unit J255.

When the control voltage is applied to the electromagnet control valve, a plunger in the control valve moves. The period of the control voltage applied determines the amount of travel. The adjustment changes the cross-section of the opening between the suction and the high pressure sides in the valve. High pressure rises as the suction pressure drops. This causes the piston stroke to reposition the swash plate at a greater angle.

CLIMATronic control unit J255

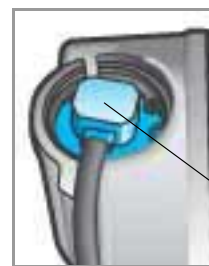

Compressor regulating valve N280



Influencing parameters:

- Input of desired temperature
- Ambient temperature
- Interior temperature
- Temperatures downstream of evaporator and air outlets
- Pressure level in refrigerant circuit

Outlet temperature sender G263

The outlet temperature sender G263 is located in the air duct behind the evaporator. It detects the vent temperature downstream of the evaporator.

It fulfills two important tasks:

- it ensures that the air conditioning system is switched off at 0°C downstream of the evaporator.
- together with the externally regulated compressor, the outlet temperature downstream of the evaporator can now be regulated between 0°C and approx. 10°C.

Advantage:

It is no longer for the heat exchanger to "reheat" cold air when the outlet temperatures are between 0°C and 10°C.

This reduces power consumption and saves fuel.

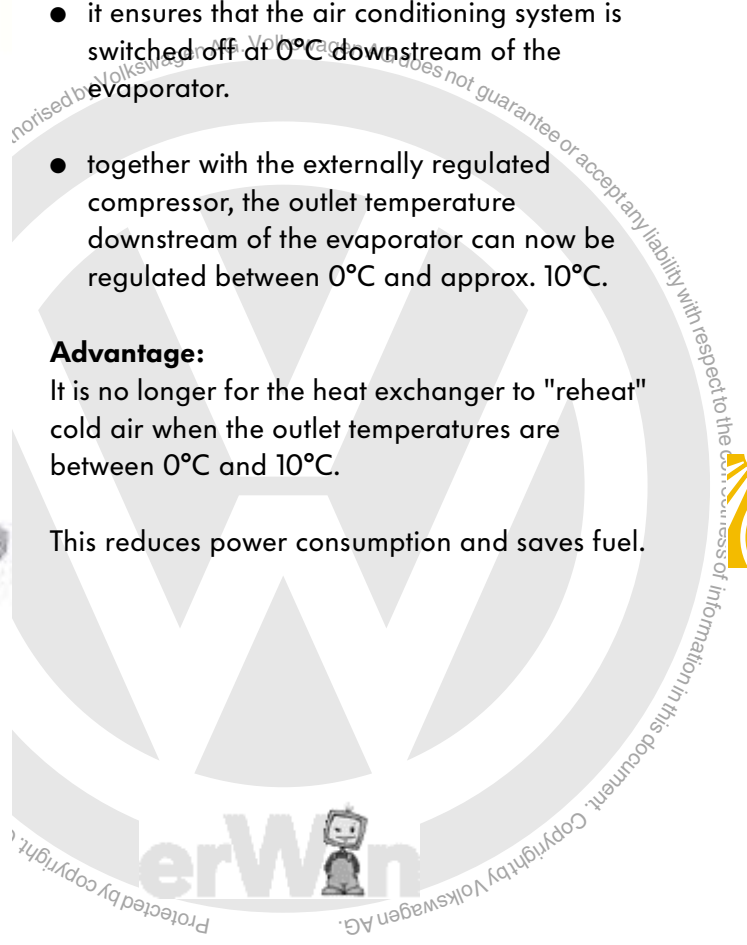
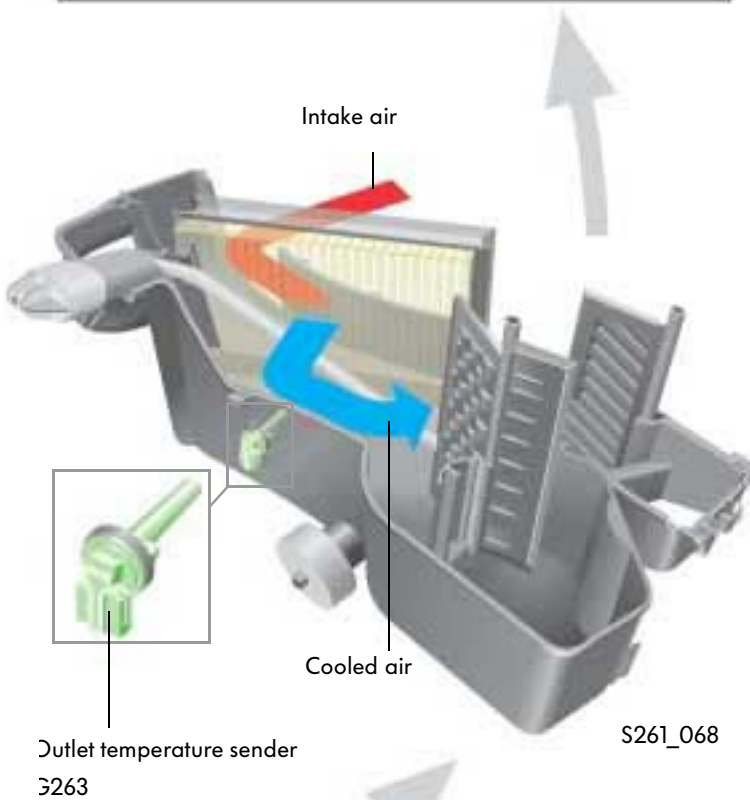

Notes

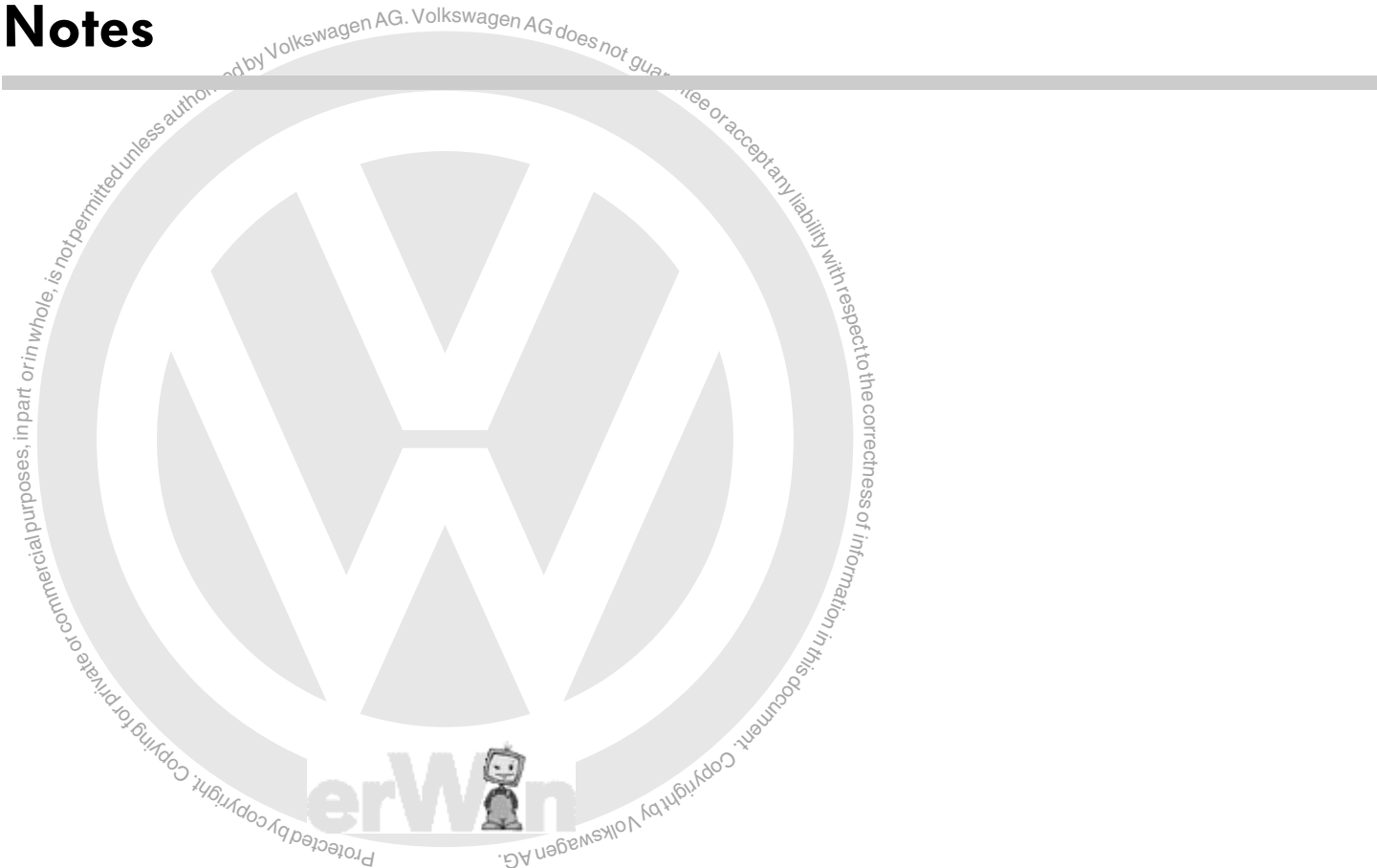





whole, is m

Protected by copyright. Volkswagen AG.

For internal use only © VOLKSWAGEN AG, Wolfsburg

All rights reserved. Technical specifications subject to change without notice.

140.2810.80.20 Technical status: 08/01

 This paper is produced from non-chlorine-bleached pulp.