

Service.



Self-Study Programme 252

1.4 l 77 kW Engine with Petrol Direct Injection System in the Lupo FSI

Design and Function



Volkswagen is fitting a direct-injection petrol engine for the first time in the Lupo FSI. The engine in question is a 1.4-litre unit developing 77kW (105 bhp).

The abbreviation **FSI** stands for **Fuel Stratified Injection**. This describes the type of injection used in the fuel-saving operating mode.

By virtue of the petrol-direct injection system in particular, fuel consumption is reduced by as much as 15% compared with a similar engine equipped with an intake manifold injection system.

However, the engine mechanicals were also modified in order to reduce fuel consumption even further.

For more detailed information on the petrol-direct injection system, please refer to Self-Study Programme 253 which describes the engine management system of the 1.4-litre 77kW engine.



252_110

New



Important
Note



This Self-Study Programme explains the design and function of new developments. The contents are not updated.

Please always refer to the relevant Service Literature for current inspection, adjustment and repair instructions.

Table of contents



Introduction	4
Specifications	5
Engine mechanicals	6
Toothed belt drive	6
Intake manifold with intake manifold-lower section ..	7
Cylinder head	8
Camshafts.....	9
Camshaft timing control	10
Cylinder block	14
Crankcase breather	16
Piston.....	17
Engine management	18
System overview	18
Engine control unit	20
Operating modes	21
Intake system	26
Fuel system.....	34
Exhaust system.....	39
Cooling system.....	49
Function diagram	50
Test your knowledge	52
Service	54
Special tools	54



Protected by copyright. Copying for private or commercial purposes, in part or in whole, is not permitted unless authorised by Volkswagen AG. Volkswagen AG does not guarantee or accept any liability with respect to the correctness of information in this document. Copyright by Volkswagen AG.

Introduction



The 1.4-litre 77kW engine with petrol-direct injection is a further development of the 1.4-litre 74kW engine used in the model year 2000 for the Polo.



252_077

The parts of the engine mechanicals adopted from the 1.4-litre 74kW engine used in the Polo are shown below. For a more detailed description, please refer to Self-Study Programme No. 196.

Valve gear



252_004

The valve gear comprises the valves, the roller rocker arms and the support elements.

Sealing flange with integrated sender wheel



252_047

A sealing flange with integrated sender wheel for engine speed sender G28 is used on the clutch side.

Crankshaft

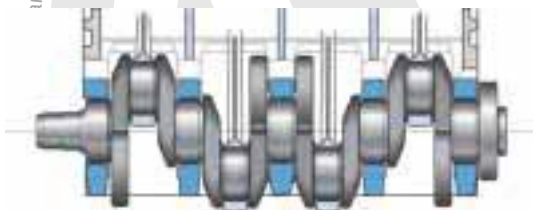

252_010

The crankshaft runs in five bearings. The bearing covers must not be detached.

Conrod

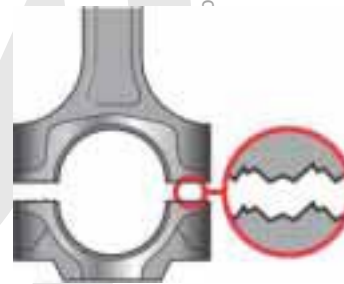

252_009

Cracked conrods are used.

Oil pump



252_045

A Duo-Centric oil pump is used.

Oil cooler



252_011

Adopted from the 1.6-litre 92 kW engine, the oil cooler is integrated in the cooling system on account of the increased amount of heat dissipation to the engine oil.

The 1.4-litre 77kW engine

Maximum power output is 77kW at 6200 rpm.
Maximum torque is 130 Nm at an engine speed of 4500 rpm.

The Lupo FSI, like the Lupo 3L, has an ECO mode. In this mode, average fuel consumption is 4.9 l per 100 km in accordance with the MVEG standard.

Engine speed is limited to 4000 rpm and full throttle injection quantity is reduced. Maximum power output is 51 kW and maximum torque is 125 Nm at 4000 rpm.

The power output and torque figures at engine speeds up to 4000 rpm are approximately 3 % below those shown in the adjacent diagram.

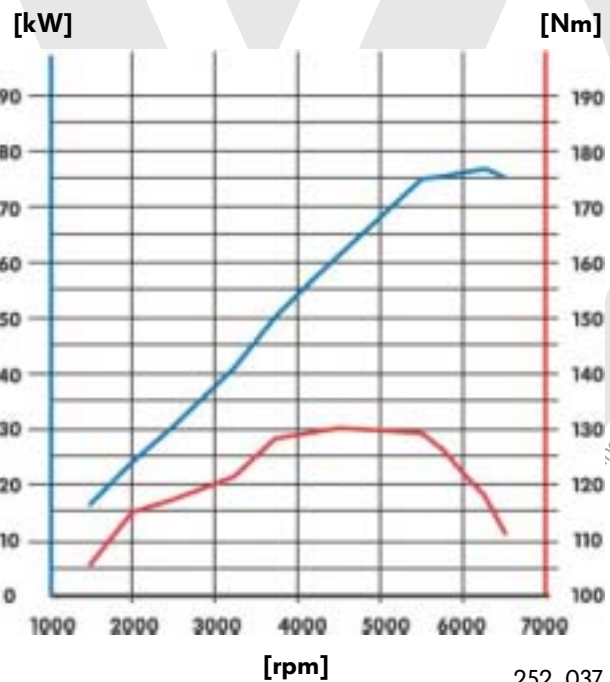

Differences compared with the Lupo 3L

- The Lupo FSI does not have a stop/start function. During stationary phases, therefore, the engine continues to run. This prevents the catalytic converters cooling down to below their working temperature.
- In overrun phases, the clutch is not disengaged. Consequently, overrun shut-off remains active for as long as possible.

Engine code	ARR
Type	4-cylinder inline engine
Valves per cylinder	4
Displacement in cm ³	1390
Bore / stroke in mm	76.5 / 75.6
Compression ratio	11.5 : 1
Engine management	Bosch Motronic MED 7.5.10
Fuel	Premium unleaded with RON 98
Exhaust gas aftertreatment	Lambda control, three-way catalytic converter, NOx storage catalytic converter
Exhaust emission standard	EU 4



In the event of a loss of power and torque as well as increased fuel consumption, the engine runs on premium unleaded RON 95. The increased fuel consumption is the result of the higher sulphur content in the fuel, which is detrimental to petrol-direct injection engines in particular.

Engine mechanicals

Toothed belt drive

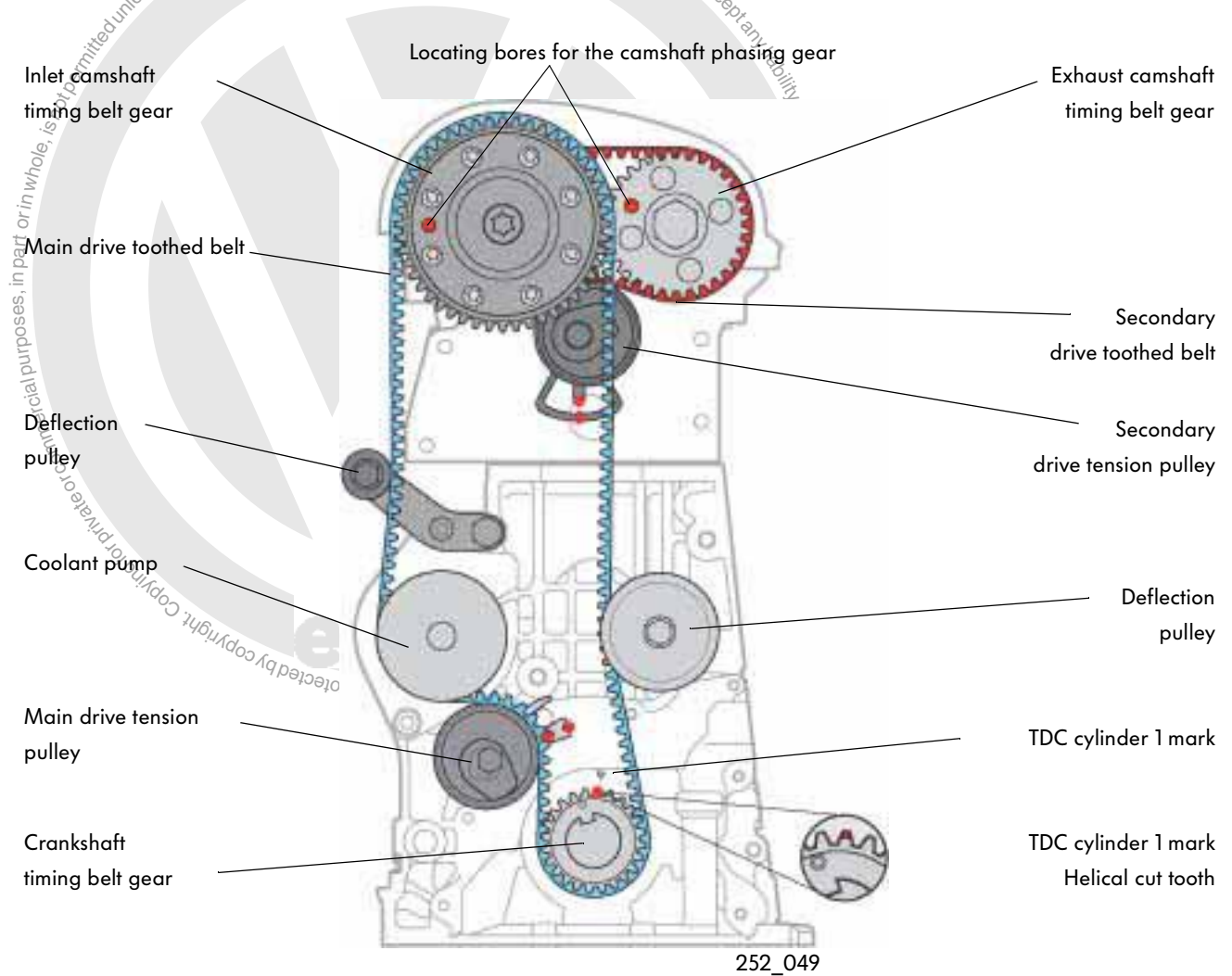

The toothed belt drive was adopted from the 1.6-litre 92kW engine of the Polo GTI.

In the main drive, the coolant pump and the inlet camshaft are driven by the crankshaft. A semiautomatic tension pulley and two deflection pulleys stabilise the motion of the toothed belt.

In the secondary drive, the inlet camshaft drives the exhaust camshaft by means of a second toothed belt. The toothed belt is tensioned by a semiautomatic tension pulley.

The intake manifold

The intake manifold is made of die cast aluminium.

A chamber serving as the vacuum box is cast into the intake manifold. The vacuum box ensures that the vacuum required to control the intake manifold flap is present in the intake manifold lower section.

For further information on the intake manifold flap changeover mechanism, refer to page 28.

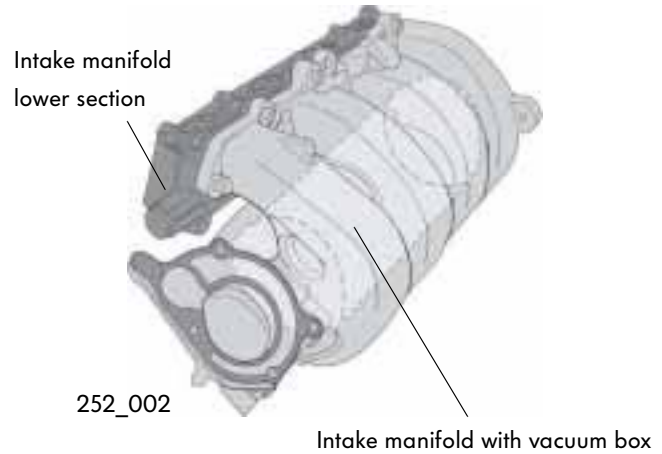

Intake manifold lower section

The intake manifold lower section is made of die cast aluminium and bolted onto the cylinder head.

The components of the intake manifold lower section are as follows:

- four intake manifold flaps which control air flow in the cylinder head
- an integrated fuel manifold
- fuel pressure regulating valve
- fuel pressure sender
- intake manifold flap potentiometer
- vacuum actuator

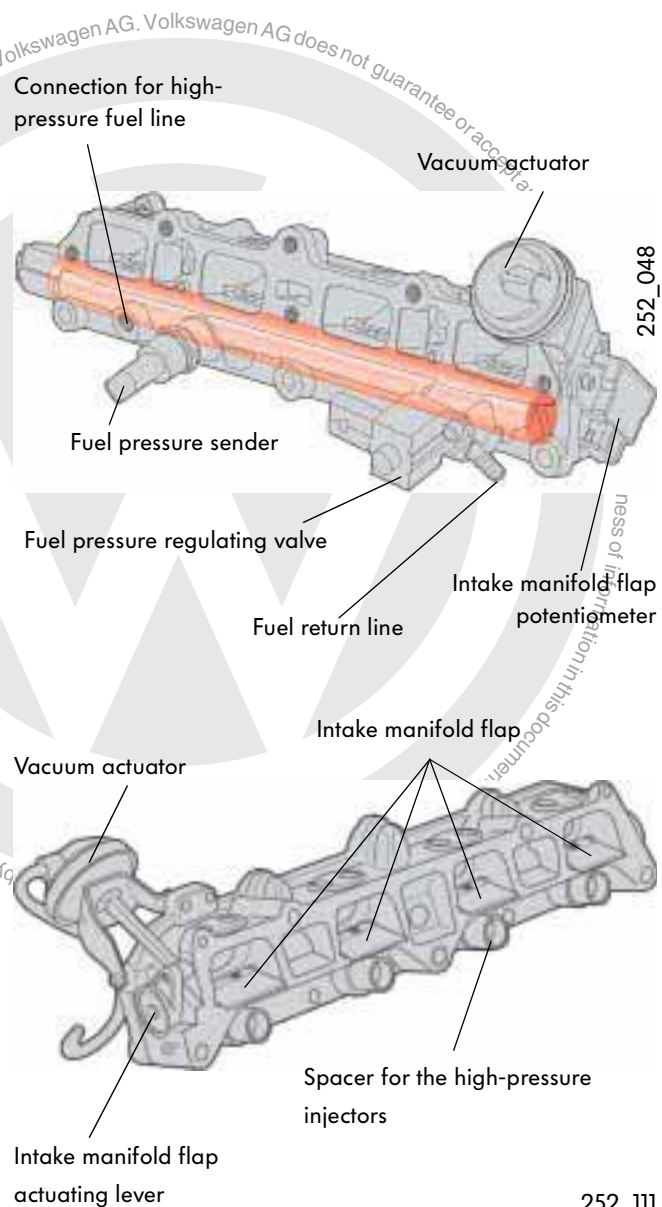

When attaching the intake manifold lower section to the cylinder head, it is necessary to slightly actuate the intake manifold flaps. The intake manifold flaps must not be retained between the cylinder head and the intake manifold lower section or have contact with the press-fitted panels in the intake duct of the cylinder head.

Engine mechanicals

Cylinder head

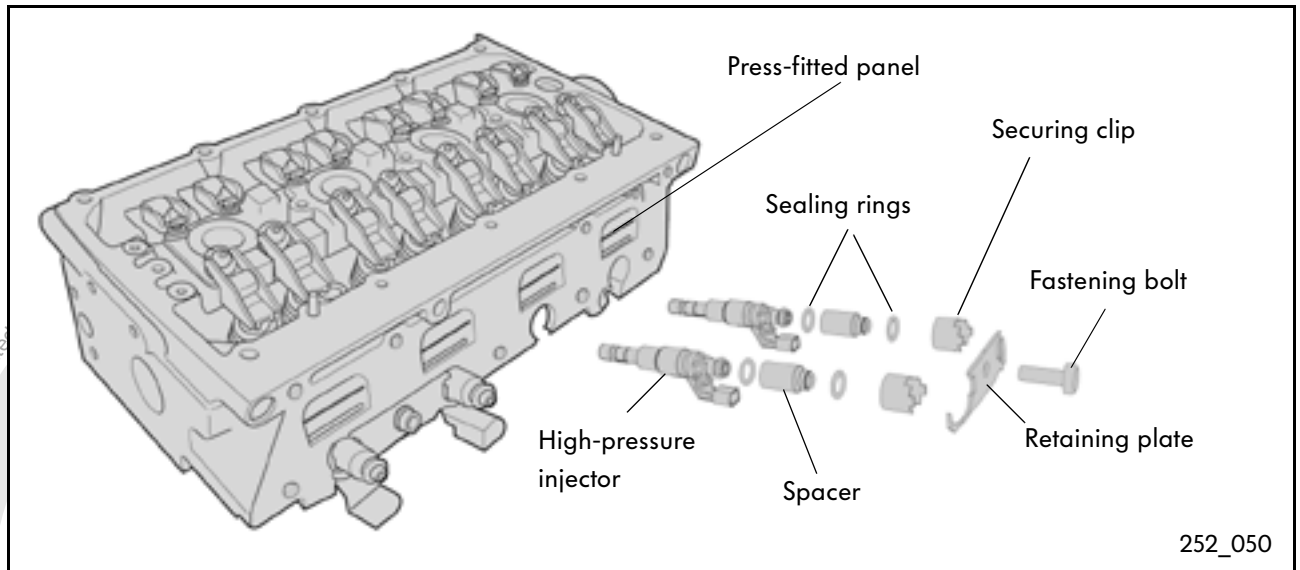

The cylinder head, which has 4 valves per cylinder and a roller rocker arm, was adapted to the petrol-direct injection system.

- The high-pressure injectors and the valve gear are integrated in the cylinder head.
- The intake manifold with the intake manifold lower section and the camshaft housing are attached by bolts.
- The intake duct is divided by a press-fitted panel into a lower duct and an upper duct.

The special features of the cylinder head

The intake duct is divided into a lower duct and an upper duct by a press-fitted panel. If the lower duct is closed by the intake manifold flaps, the air flows into the cylinder along the upper duct. If the lower duct is open, the maximum air mass can flow along both ducts into the cylinder.

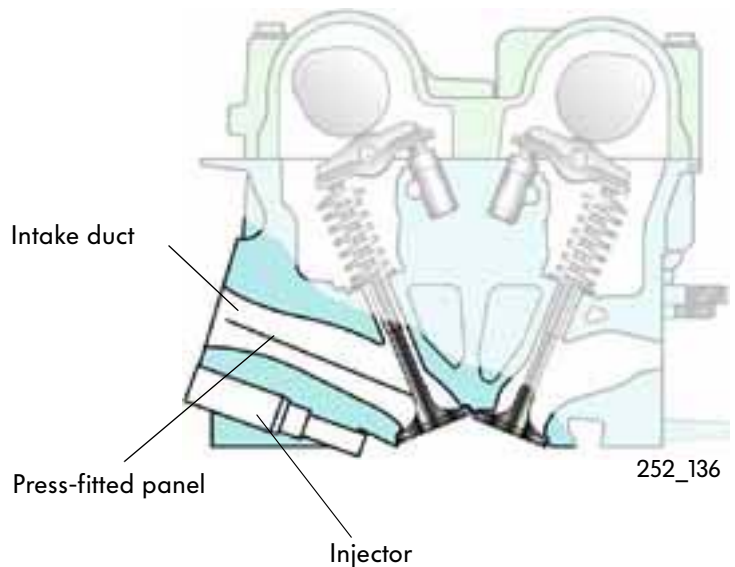

Camshafts



252_001

Built-up camshafts are used. The cams are slipped onto a hollow shaft and fixed in place so that they fit exactly. The hollow shaft is then widened hydraulically and the cams are securely located.

The advantages of the two built-up camshafts over cast iron shafts are as follows:

- weight saving of 1.4 kg
- twice the flexural rigidity

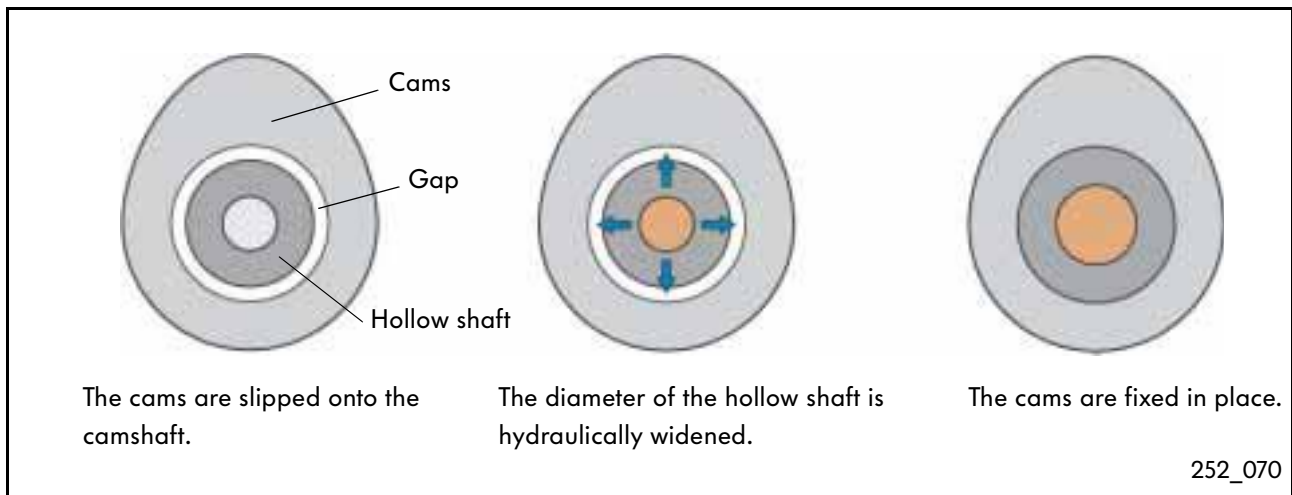

The camshaft housing

In the camshaft housing, the two camshafts are mounted on 3 bearings.

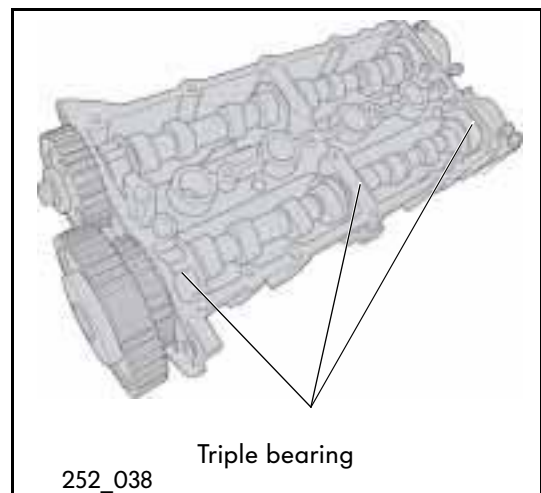

Engine mechanicals

Camshaft timing control

The 1.4-litre 77kW engine features a variable intake port camshaft timing control. The camshaft timing control is identical to that used in the 1.6-litre 92kW engine of the Polo GTI.

The advantages are:

- improved torque profile
- reduced emission and lower fuel consumption thanks to optimised inner exhaust gas recirculation.

The camshaft is adjusted at speeds above 1000 rpm depending on engine load and speed. The max. camshaft adjustment is 40° crankshaft angle from the home position in the "advance" direction .

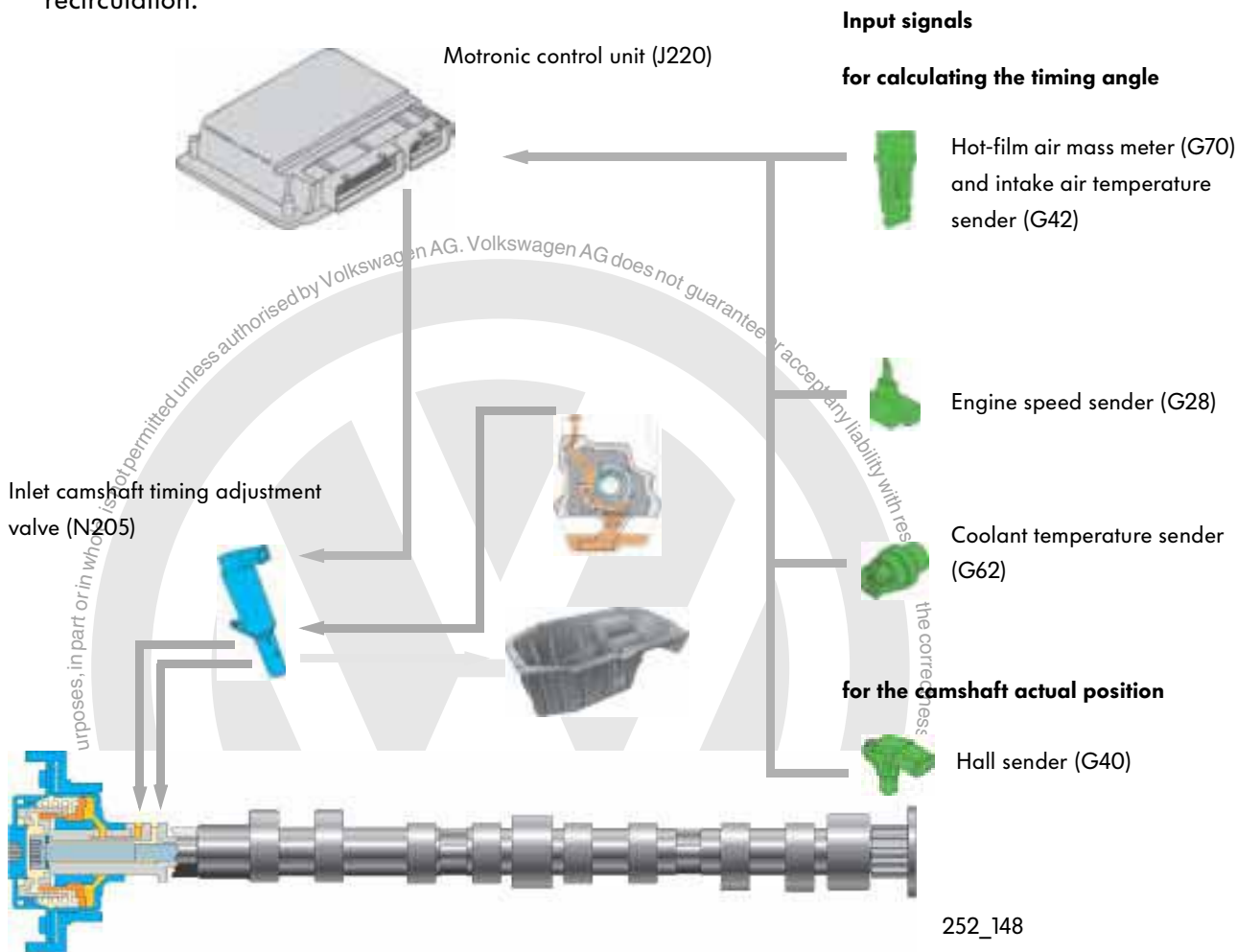

The camshaft is adjusted depending on characteristic maps based on the "engine load" and "engine speed" input signals. The coolant temperature serves as additional information. The engine control unit uses this

information to activate the camshaft timing control and enable advance adjustment or retard adjustment. The Hall sender (G40) recognises the position of the camshaft.

The mechanical construction of the camshaft adjustment unit

The camshaft adjustment unit and the inlet camshaft gear form a unit, and therefore require very little space.

The camshaft adjustment unit is attached to the inlet camshaft by bolts and integrated in the engine's oil circuit.

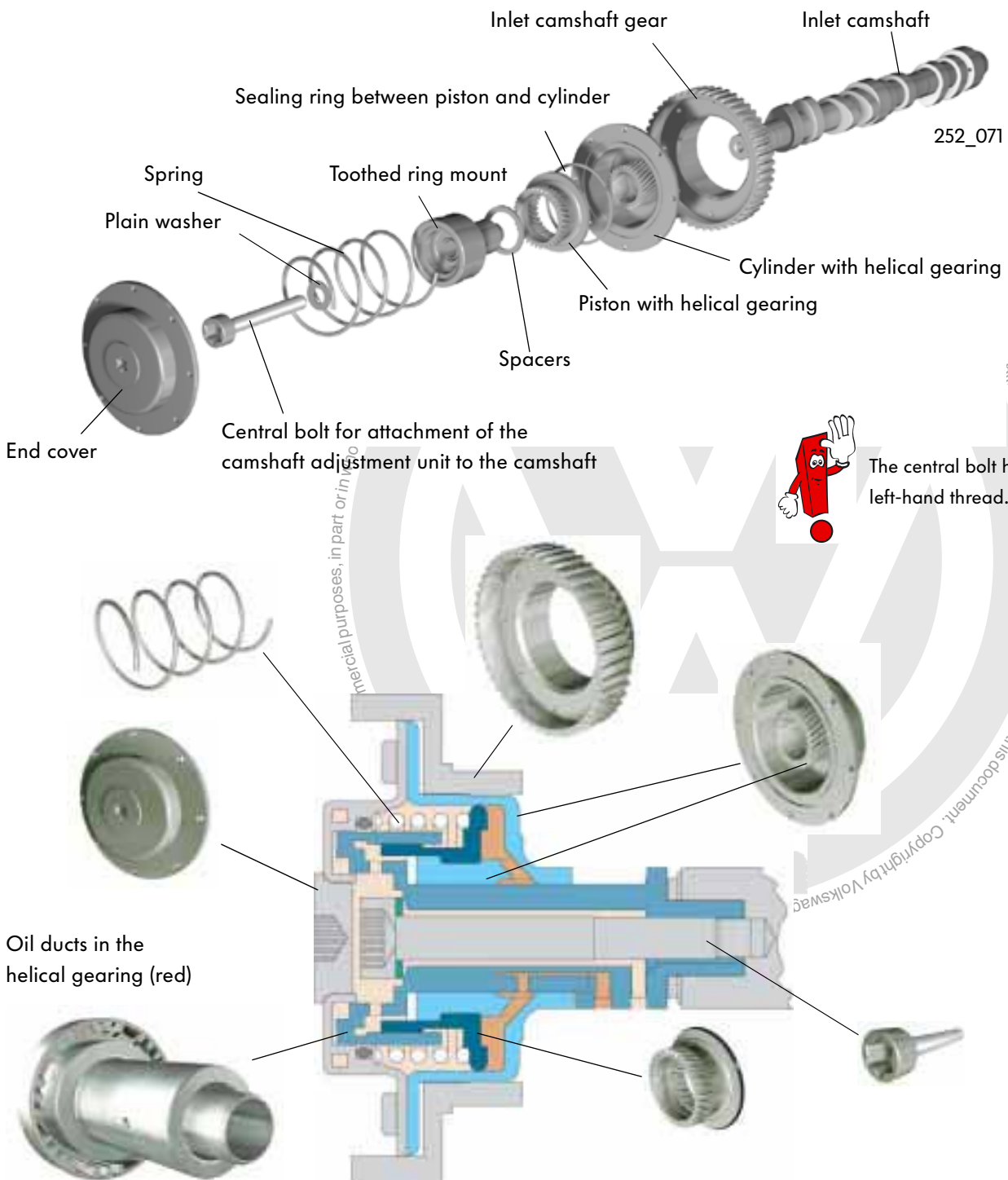

252_121-128

Engine mechanicals

Function

The camshaft adjustment unit is attached to the inlet camshaft by bolts. The inlet camshaft is adjusted according to the helical gearing principle.

The means:

The piston in the adjustment unit can be moved in the longitudinal direction by applying oil pressure.

The piston is rotated simultaneously because it is mounted on a helical-cut gear.

The toothed ring mount, which the inlet camshaft is bolted to, rotates together with the piston. The position of the camshaft is thus adjusted (see Fig. 252_161).

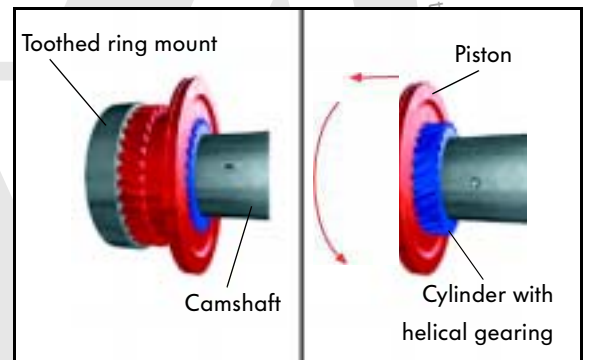
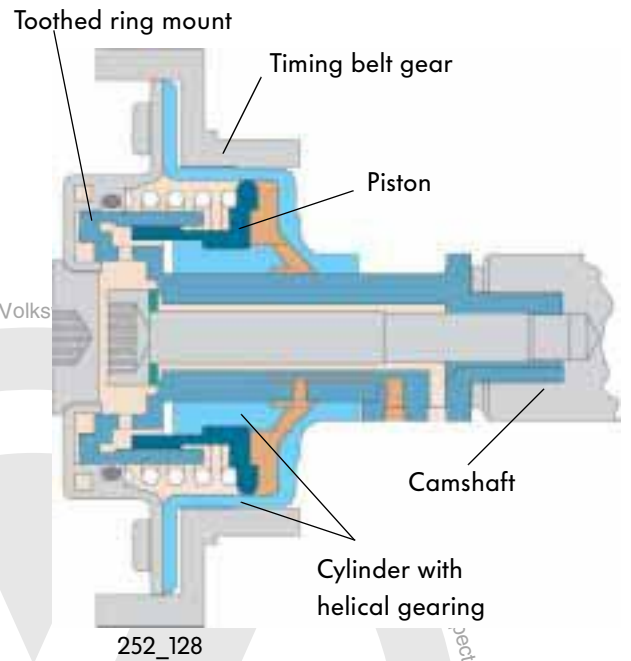

The inlet camshaft timing adjustment valve (N205)

is located on the camshaft housing and integrated in the oil circuit of the engine.

Depending on activation of the camshaft timing control valve, the oil is channelled into various ducts. The ducts are connected to the chambers on both sides of the piston.

"Ignition advance" and "retard adjustment" take place via duct B and duct A respectively.

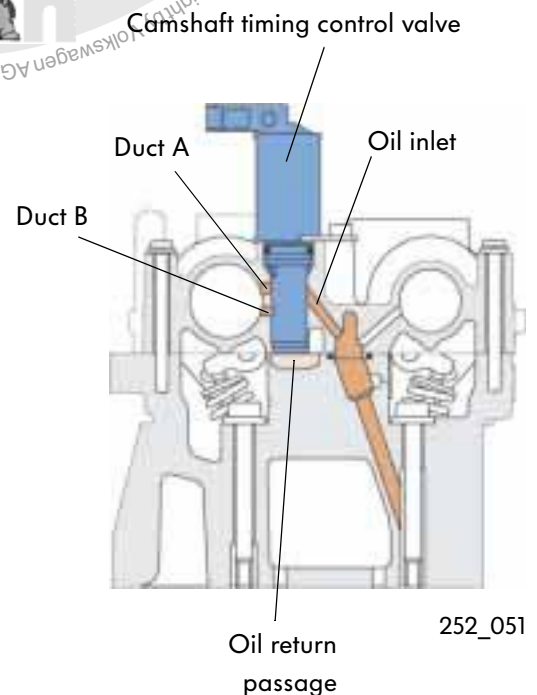

Activation of the camshaft timing control valve

Configured as a 4/3 way valve, the camshaft timing control valve is activated by the engine control unit. This means that it has four connections and three valve positions are possible.

"Retard adjustment"

For retard adjustment, the oil flows along duct A and into the adjustment unit. The piston is pushed towards the retard stop until the intake port-camshaft has reached the calculated nominal position. The oil on the other side of the piston flows along the other duct and back to the cylinder head.

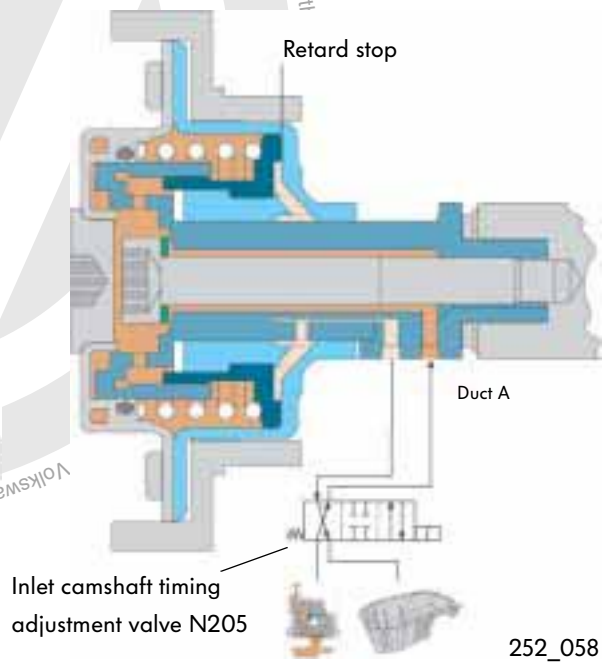

"Ignition advance"

For ignition advance, the oil is channelled into duct B. The piston is pushed in the direction of the advance stop until the inlet camshaft has reached the calculated nominal position.

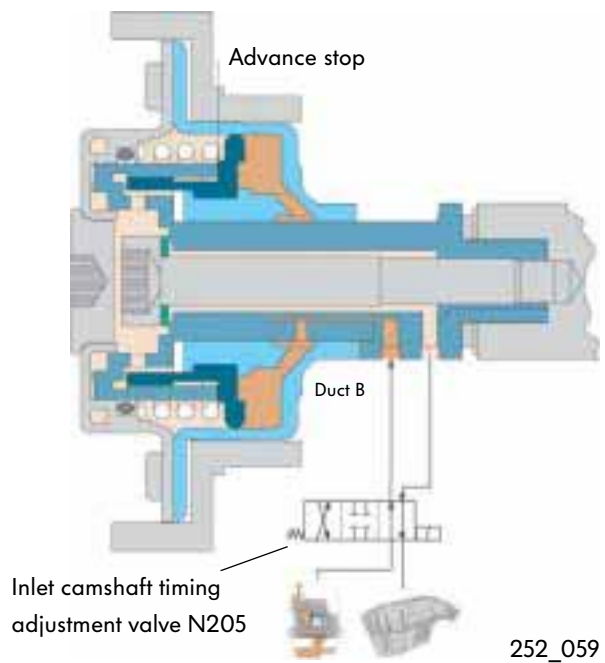

The stop position

In this position, the valve closes the two ducts (middle position) leading to the camshaft adjustment unit. Oil can neither flow in nor out. Because the piston remains in this position, the camshaft timing is not adjusted towards "advance" or "retard".



In the starting position, the piston is pushed towards the retard stop by the spring when the engine is started. This eliminates noise.



Engine mechanicals

Cylinder block

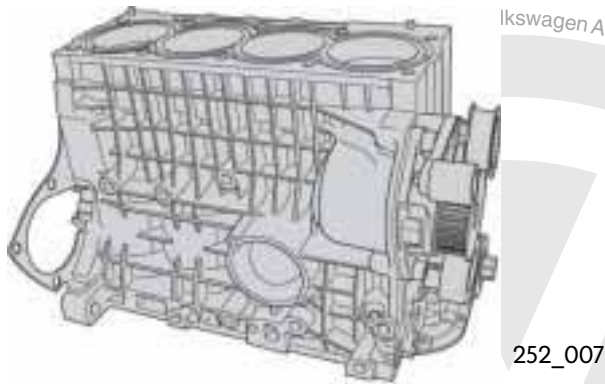

The engine mechanicals are made of a die cast aluminium alloy. For the first time, plasma-coated cylinder liners are used in an engine.

The advantages of this coating are:

- The low layer thickness of 0.085 mm reduces the weight compared to a cylinder block with press-fitted cast iron cylinder bush by approx. 1 kg.
- A plasma-coated cylinder liner reduces both friction and wear.

The principle of plasma coating

The plasma gas flows through the nozzle outlet and is ignited by an electric arc. In the process, it is heated to a temperature of approx. 11,700°C and enters the plasma state. The gas is accelerated to a max. velocity of 600 m/s.

The coating powder is sprayed into this plasma jet and thus melted. It is heated to a temperature of approx. 2,500°C and accelerated up to 150 m/s.

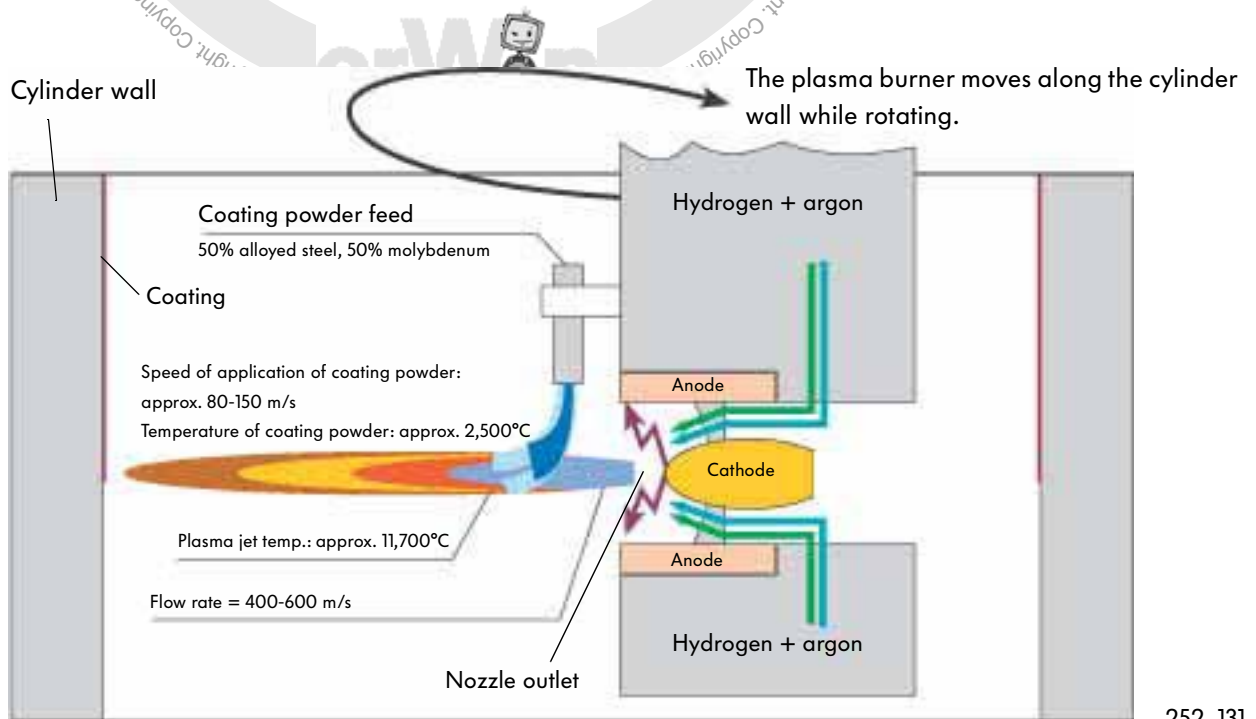

252_131

The particles penetrate surface unevenness in the cylinder wall when they impinge on the wall in a liquid state. The kinetic energy is converted into plastic deformation. Solidification of the particles creates a positive bond between the coating and the

cylinder wall. In addition, shrinkage stresses build up within the coating and produce a positive bonding between the coating and the cylinder wall.

Cylinder liners

Finally, the cylinder liners are finished by honing.

Communicative system

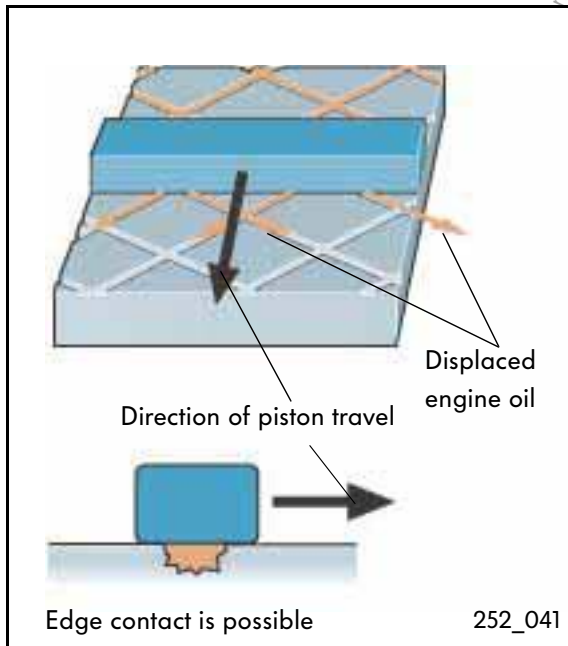

Honing of the cast iron-cylinder liners:

Honing of the cast iron-cylinder liners produces typical interconnected grooves (communicative system).

The oil is retained in these grooves and thus sufficient lubrication is assured.

The disadvantage, however, is that the piston rings push the oil ahead of them within the grooves. This can result in contact between the piston rings and the cylinder liner.

The process is known as "mixed friction" and results in increased friction and wear.

Microchamber system

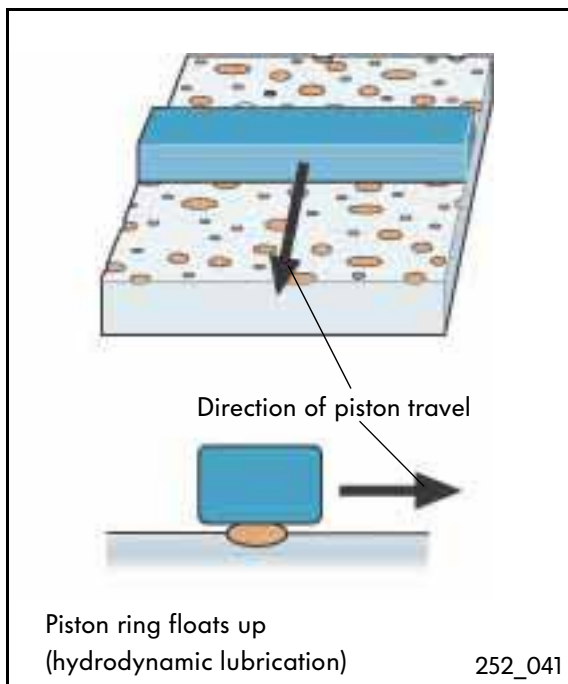

Honing of the plasma-coated cylinder liners:

The honing grooves in plasma-coated cylinder liners are shallower. Honing produces level surfaces with small recesses (microchamber systems) which retain the oil. These surfaces in the plasma layer require no additional machining and are fully integrated.

When the piston ring passes through a microchamber, pressure is produced within the chamber and acts against the piston ring. This backpressure causes the piston ring to float up on an oil pocket, ensuring hydrodynamic lubrication. Friction and the wear are thus reduced.

The crankcase breather

The crankcase breather comprises an oil separator on the cylinder block and a low-pressure valve on the intake manifold. It prevents oil and unburned hydrocarbons from entering the atmosphere.

The gases are drawn in from the crankcase through the vacuum present in the intake manifold.

The gases initially flow through the oil separator, where the oil is collected and recirculated within the crankcase. The remaining vapours are channelled into the intake manifold via a low-pressure valve and from here into the combustion chamber.

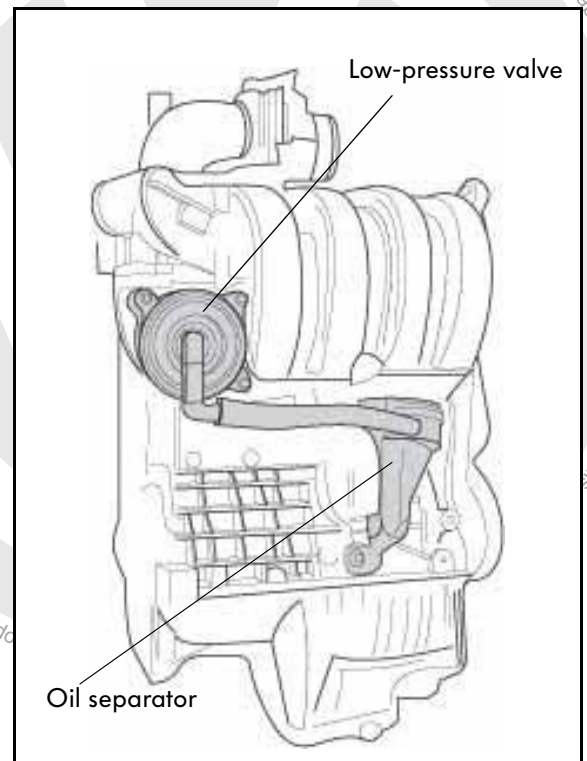

252_135

The low-pressure valve

This valve maintains a constant vacuum and ensures good crankcase ventilation. The condensate and the fuel entrained in the oil are thus extracted and the quality of the oil is improved.

The vacuum must not be too high, because otherwise the sealing rings will open inwards allowing dirt to enter the crankcase.

Function

The low-pressure valve is divided into two chambers by a membrane. One chamber leads into the open and the other chamber leads into the intake manifold and the oil separator.

With increasing vacuum inside the intake manifold, the vacuum inside the crankcase would also increase. To prevent this, the cross-section leading into the intake manifold is adjusted as a function of pressure. A constant gas flow is thus maintained.

The pressure differential between the two chambers is

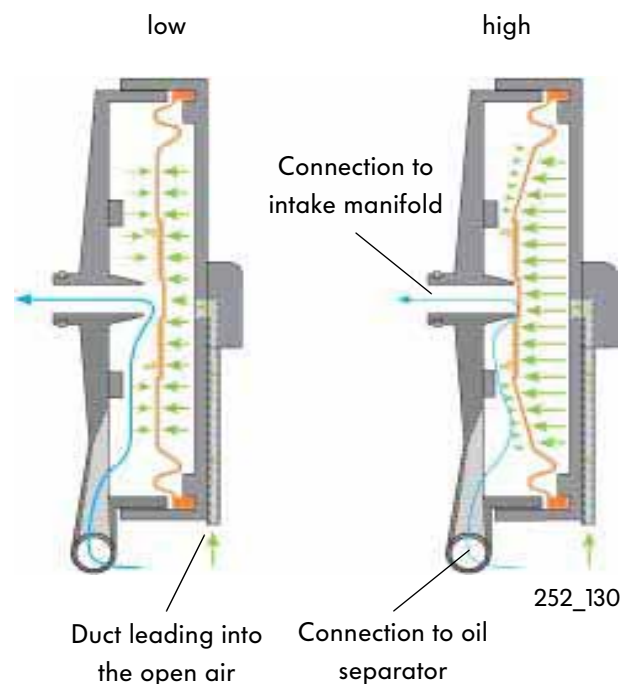

252_130



252_008

The piston base

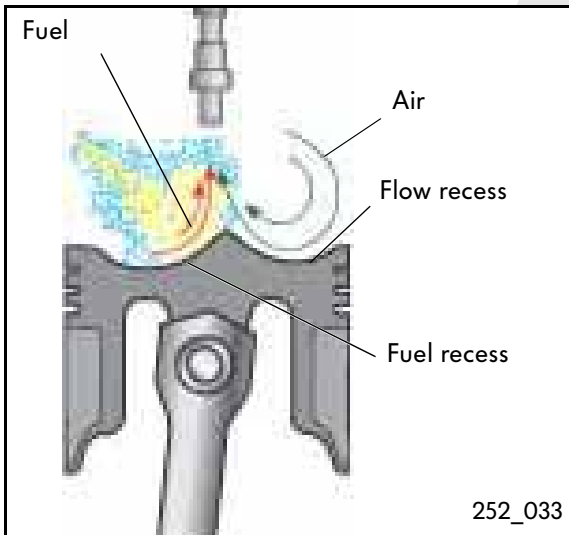

252_033

Piston

The piston is made of a die cast aluminium alloy. A fuel recess and a flow recess are machined in the piston base.

In certain engine load and RPM ranges, fuel is injected shortly before the ignition cycle commences. The fuel is directly injected onto the fuel recess and channelled towards the spark plug.

The intake air is also channelled to the spark plug through the flow recess and mixes with the fuel in the process.

An ignitable mixture forms in the area of the spark plug.



For further information on mixture preparation, refer to "Operating modes" on page 21.

The compression rings

are adapted to the plasma-coated cylinder liners. Thanks to the good lubrication properties of a plasma-coated cylinder liner, it is possible to use less preload compared to conventional piston rings. Frictional behaviour is thus improved.

The oil taper ring

The oil taper ring comprises three component parts.



252_034



is not perm. ... unless authorised by Volkswagen AG. Volkswagen AG does not guarantee or accept any liability with respect to the correctness of information in this document. Copyright by Volkswagen AG.

Engine management system

System overview

Air-mass flow meter **G70**,

Intake air temperature sender **G42**

Intake manifold pressure sender **G71**

Engine speed sender **G28**

Hall sender **G40**

Throttle valve control unit **J338**,
angle sender + 2 **G187, G188**

Accelerator pedal position sender **G79**,

Accelerator pedal position sender -2- **G185**

Brake light switch **F**,

Cruise cont. sys. brake pedal switch **F47**

Fuel pressure sender **G247**

Intake manifold flap potentiometer **G336**

Knock sensor **G61**

Coolant temperature sender **G62**

Coolant temperature sender - radiator outlet **G83**

Rotary knob temperature selection potentiometer **G267**

Exhaust gas recirculation potentiometer **G212**

Lambda probe **G39, Z19**

Exhaust gas temperature sender **G235**

NOx sender **G295**,

NOx sensor control unit **J583**

Brake servo pressure sensor **G294**

Auxiliary input signals

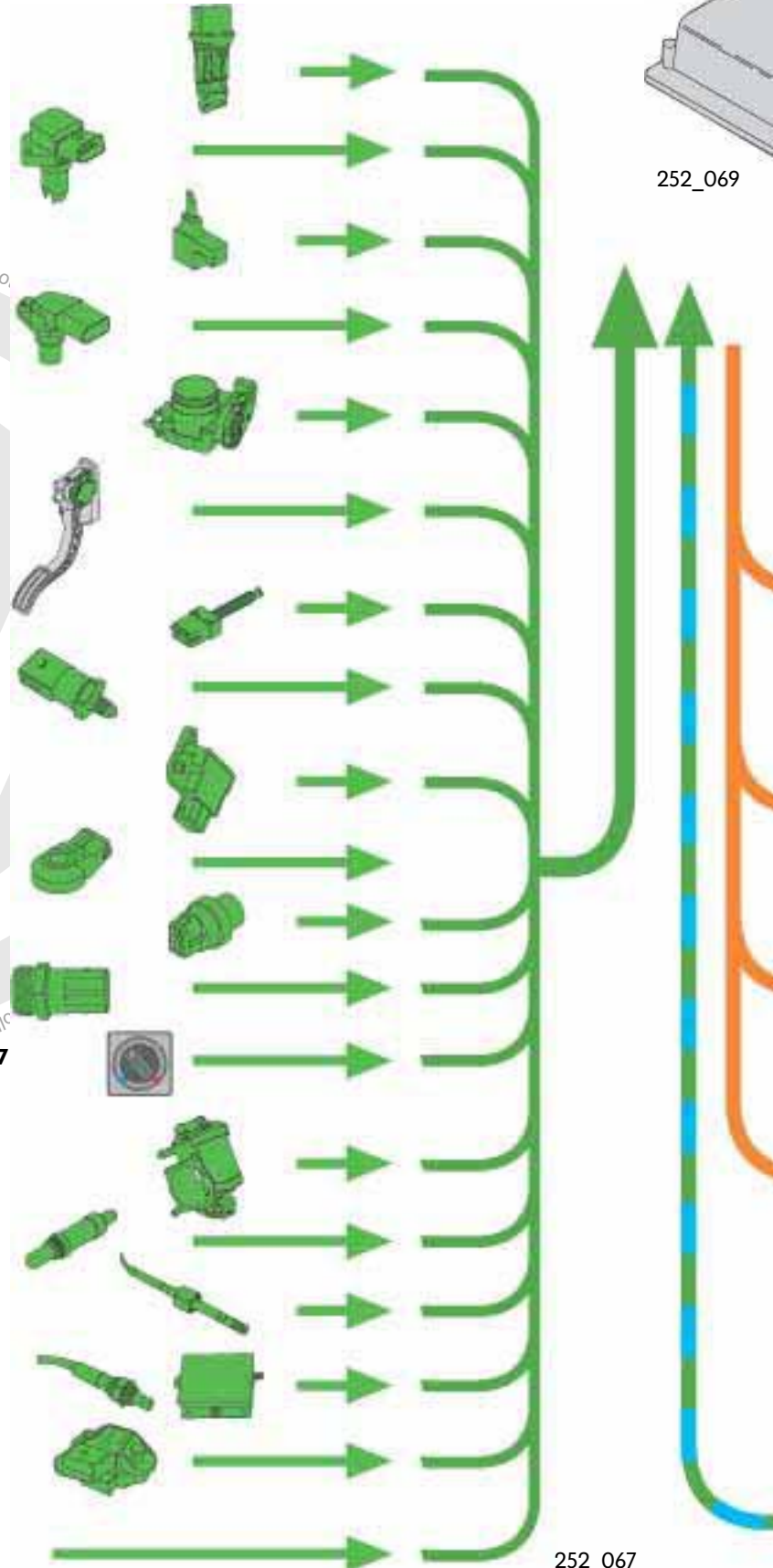

252_069

252_067

is not permitted unless authorised by Volkswagen AG. Volkswagen AG does not guarantee or accept any liability with respect to the correctness of the information.

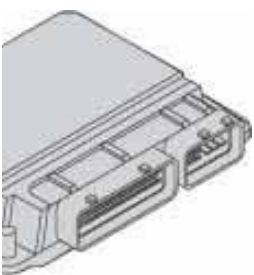

Motronic control unit **J220**



Electronic manual gearbox control unit **J514**



Airbag control unit **J234**



Control unit with display in dash panel insert **J285**



ABS control unit **J104**

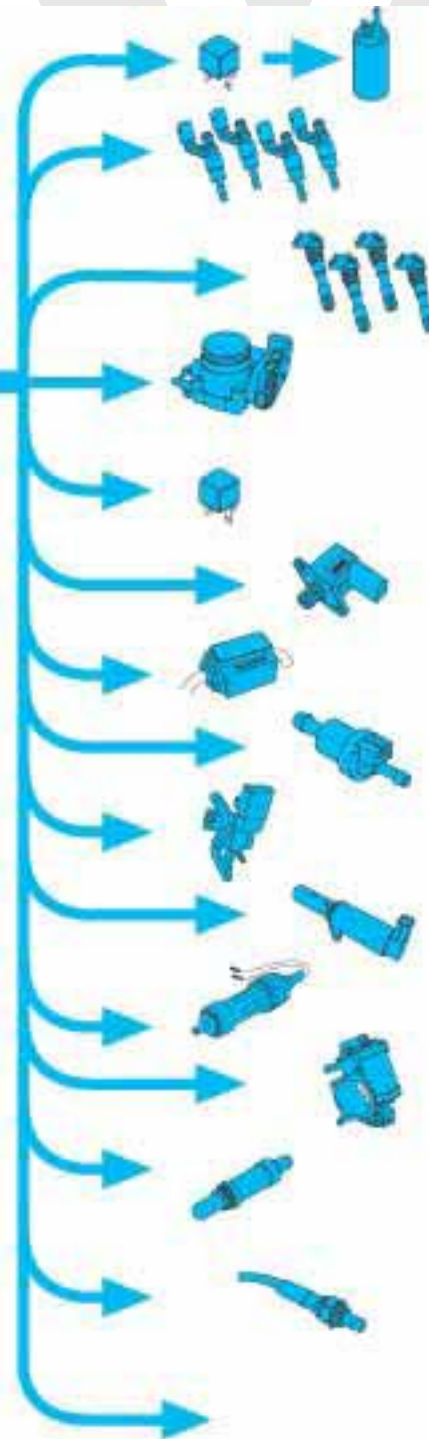

- Fuel pump relay **J17**
- Fuel pump **G6**
- Injector, cylinders 1-4 **N30-N33**
- Ignition coils 1 - 4 **N70, N127, N291, N292**
- Throttle valve control unit **J338**
- Throttle valve drive **G186**
- Motronic current supply relay **J271**
- Fuel pressure regulating valve **N276**
- Fuel metering valve **N290**
- Activated charcoal filter system solenoid valve 1 **N80**
- Intake manifold flap air flow control valve **N316**
- Inlet camshaft timing adjustment valve **N205**
- Mapped-controlled engine cooling thermostat **F265**
- Exhaust gas recirculation valve **N18**
- Lambda probe heater **Z19**
- NOx sender heater **Z44**
- Auxiliary output signals



Diagnostic connection



Engine management system

Engine control unit

The engine control unit is housed in the plenum chamber and has 121 pins.

The engine control unit in question is the Bosch Motronic MED 7.5.10 engine management system, an advanced development of the Bosch Motronic ME 7.5.10 featuring "electric throttle control".

Bosch Motronic MED 7.5.10 also includes a petrol-direct injection function.

With this system, the fuel is injected directly into the cylinder and no longer into the intake manifold.



252_075

The designation MED 7.5.10 stands for:

M = Motronic

E = Electric throttle control

D = Direct injection

7. = Version

5.10 = Development level

Operating modes

The petrol-direct injection system has two operating modes. In both modes, the fuel quantity is optimally adapted to the engine's torque and power demands.

Stratified charge mode

The engine runs in lean stratified charge mode up to the medium engine load and speed range. This is possible because the fuel is not injected until the end of the compression stroke. On commencement of the ignition cycle, a stratified fuel distribution builds up inside the combustion chamber.

The inner stratum is located in the area of the spark plug and is made up of an ignitable mixture.

The outer stratum envelops the inner stratum and is ideally made up of induced air and incoming exhaust gases.

The resulting lambda values lie between 1.6 and 3 with reference to the combustion chamber as a whole.

Homogeneous mode

In the upper engine load and speed ranges, the engine management system changes over to homogeneous mode.

The fuel is now injected directly into the cylinder during the intake stroke.

Here, the fuel mixes homogeneously with the intake air in the entire cylinder like in an engine with intake manifold injection system.

In homogeneous mode, the engine runs at lambda 1.

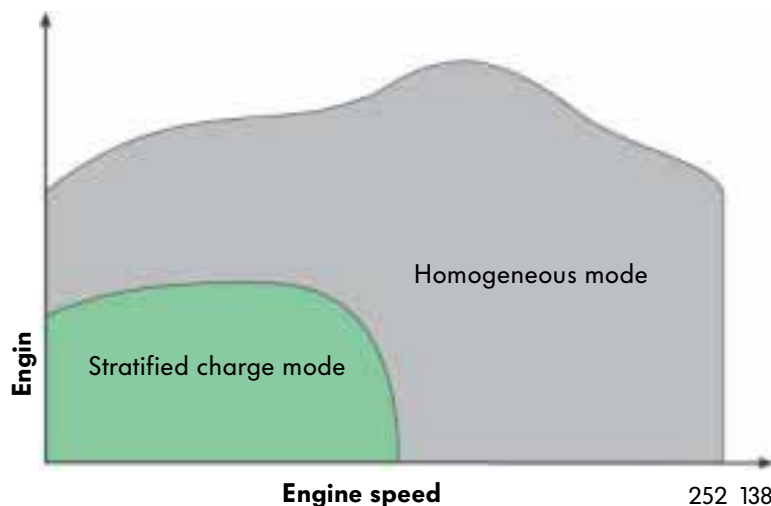

Stratified charge mode is not possible across the entire mapped-controlled range. The range is limited because a richer mixture is required with increasing engine load, thus reducing the fuel consumption advantage. Furthermore, combustion stability deteriorates at lambda values below 1.4 because there is no longer enough time available for mixture preparation at increasing engine speeds and the increasing turbulence of the air stream has a detrimental effect on combustion stability.



Engine management system

Stratified charge mode

Several conditions have to be met before the engine management system can enter stratified charge mode:

- the engine is in the corresponding engine load and speed ranges,
- there must not be any emission-relevant faults in the system,
- coolant temperature must be above 50°C,
- the temperature of the NOx storage catalytic converter must be between 250°C and 500°C and
- the intake manifold flap must be closed.

If these conditions are met, the engine can now enter stratified charge mode.

The throttle valve is opened as widely as possible to minimize throttle losses.

The intake manifold flap closes the lower duct in the cylinder head. As a result, the intake air is accelerated and tumbles into the cylinder.

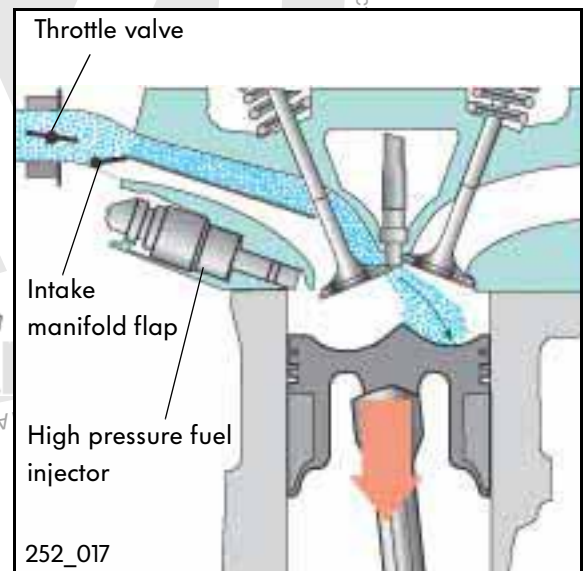

The tumble effect is reinforced in the cylinder by the special shape of the piston base.

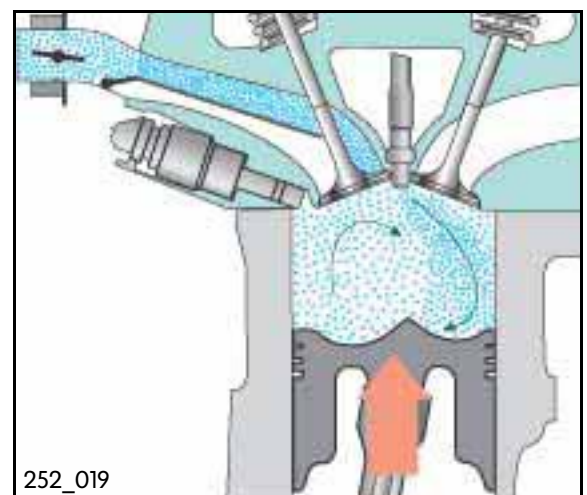

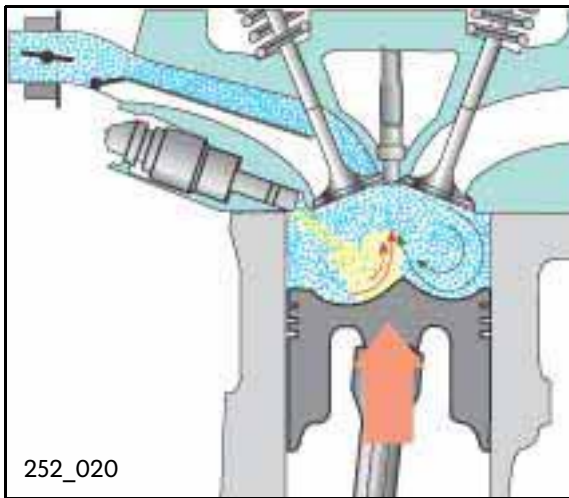

The injection cycle takes place in the last third of the compression stroke.

The fuel is injected onto the fuel recess and ducted from here towards the spark plug. Together with the tumbling air flow, the fuel is transported to the spark plug.

The fuel mixes with the induced air on the way to the spark plug.

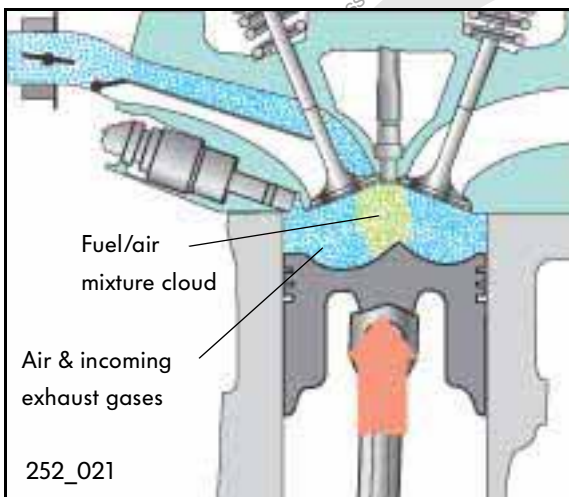

An ignitable fuel/air cloud forms in the area of the spark plug. Ideally, this cloud is enveloped in pure air and incoming exhaust gases from the exhaust gas recirculation system.

In this operating mode, the power which the engine is required to produce is governed by the injected fuel quantity only.

In this case, intake air mass is only a minor factor.

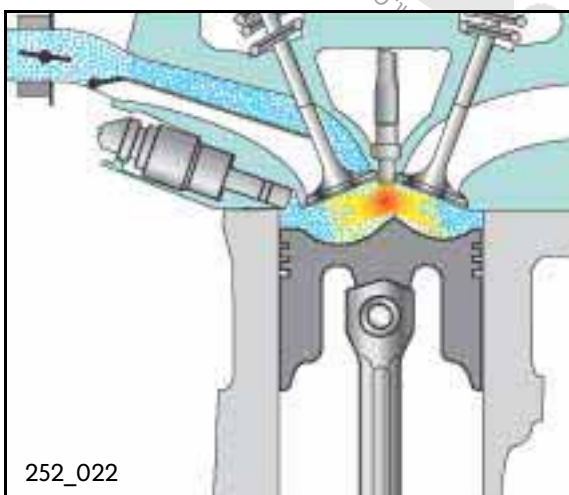

The ignition cycle commences after the fuel-air mixture has been positioned exactly in the area of the spark plug.

Only the air/fuel cloud ignites, whilst the remaining gases do not take part in the combustion process and act as an insulating envelope.



Engine management system

Homogeneous mode

Homogeneous mode is comparable to operation of an engine with an intake manifold injection system. The main difference is that the fuel is injected directly into the cylinder in the case of the petrol-direct injection engine.

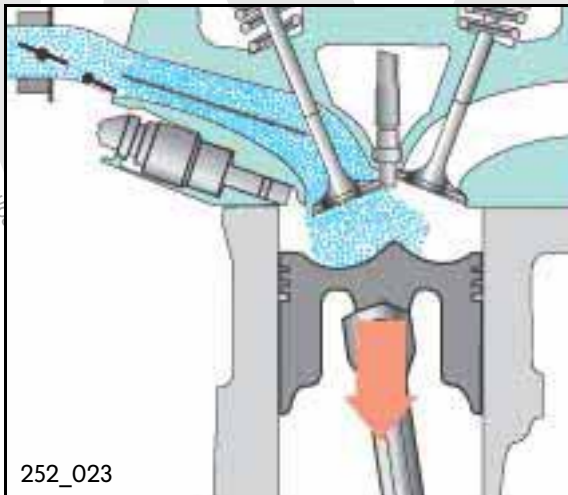

The throttle valve is opened in accordance with the accelerator pedal position . Following the changeover from stratified charge mode to homogeneous mode, the lower duct in the cylinder head remains closed. As a result, the intake air continues to tumble into the cylinder, which is beneficial to mixture formation. With increasing engine load and engine speed, the air mass which can only be induced via the upper duct would no longer be sufficient. In this case, the intake manifold flap also releases the lower duct (see Fig. on left).

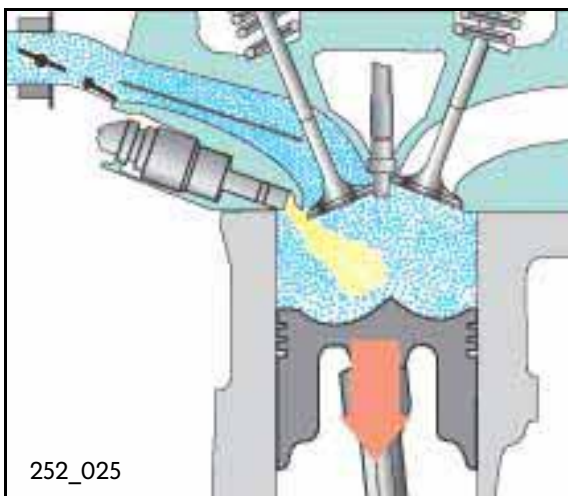

The fuel is injected directly into the cylinder during the intake stroke.



The directly injected fuel is vaporized in the cylinder and extracts a portion of the heat from the intake air. As a result, the compression ratio can increase to 11.5:1 without causing knocking combustion.

in part or in whole, is not permitted unless authorised by Volkswagen AG. Volkswagen AG does not guarantee or accept any liability with respect to the correctness of the content of this document. Copyright by Volkswagen

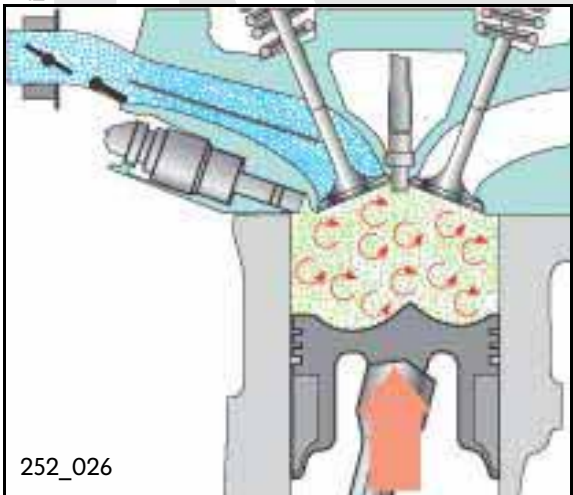

252_026

By injecting the fuel during the intake stroke, a relatively large amount of time is available for mixture formation. As a result, a homogeneous (uniformly distributed) mixture of injected fuel and induced air forms inside the cylinder. In the combustion chamber, the lambda value = 1.

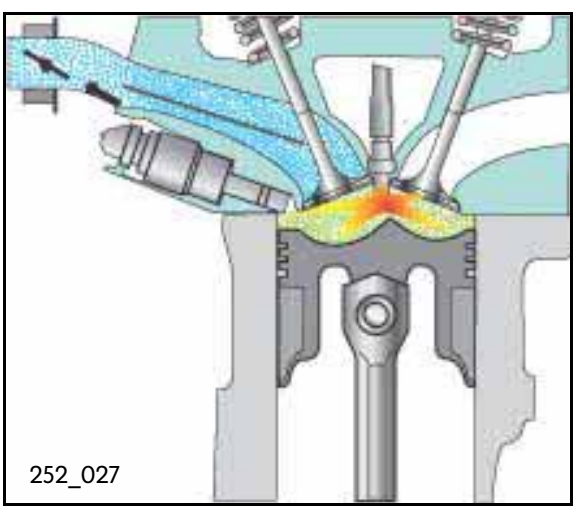

252_027

The combustion process takes place throughout the combustion chamber.

Engine management system

The intake system

was redeveloped and adapted to the requirements of a petrol-direct injection engine. As a result, it was possible to increase the exhaust gas recirculation rate to max. 35% and control air flow in the cylinder.

New features include:

- A hot-film air mass meter (G70) with intake air temperature sender (G42),
 - an electrical exhaust gas recirculation valve (N18) with the exhaust gas recirculation potentiometer (G212),
 - an intake manifold pressure sender (G71),
 - an intake manifold with a vacuum-reservoir for the intake manifold flap changeover mechanism
- an intake manifold flap changeover mechanism in combination with intake manifold flap air flow control valve (N316) and the intake manifold flap potentiometer (G336).

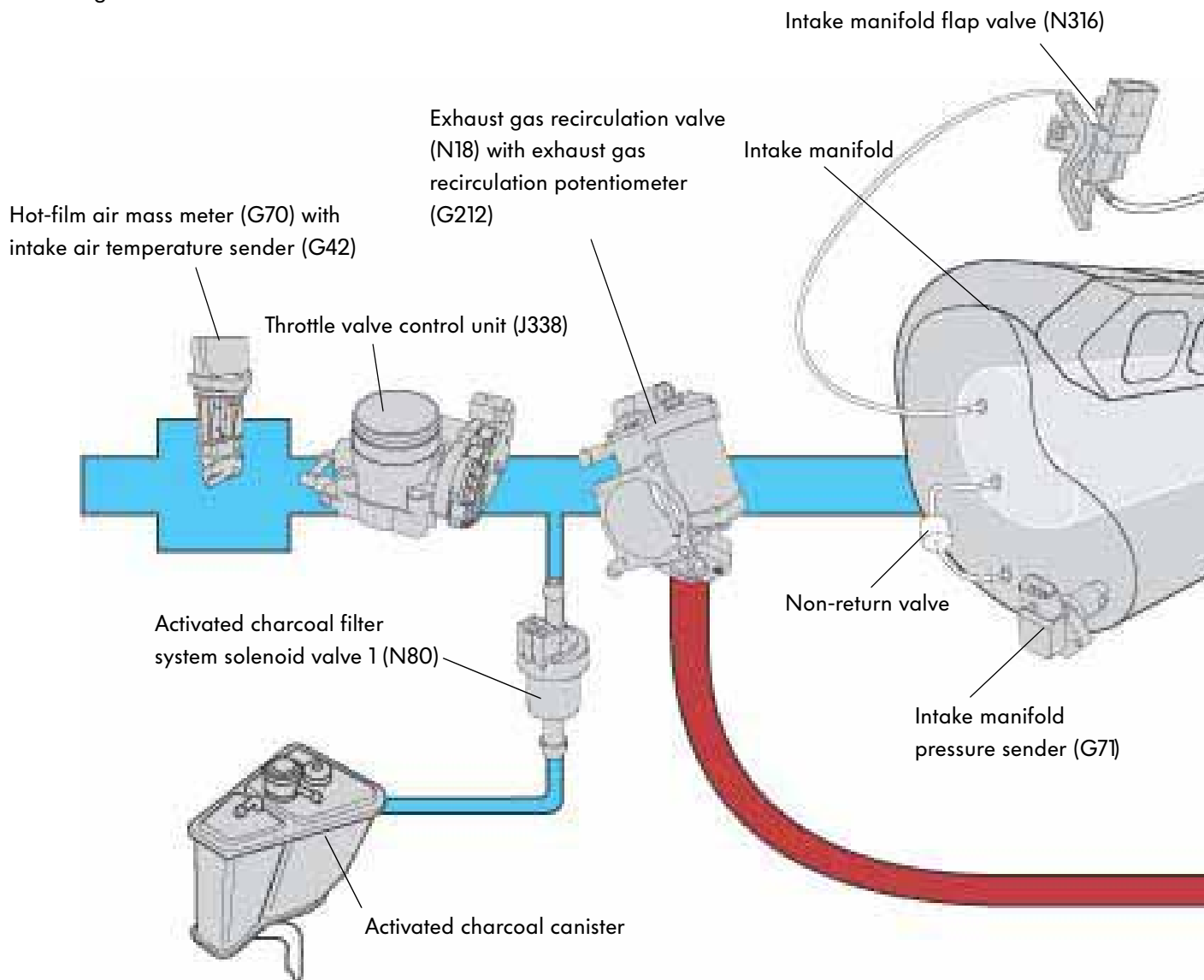

For purposes, in part or in whole, is not permitted unless authorised by Volkswagen AG. Volkswagen AG does not guarantee or accept any liability with respect to the correctness of information in this document. ©

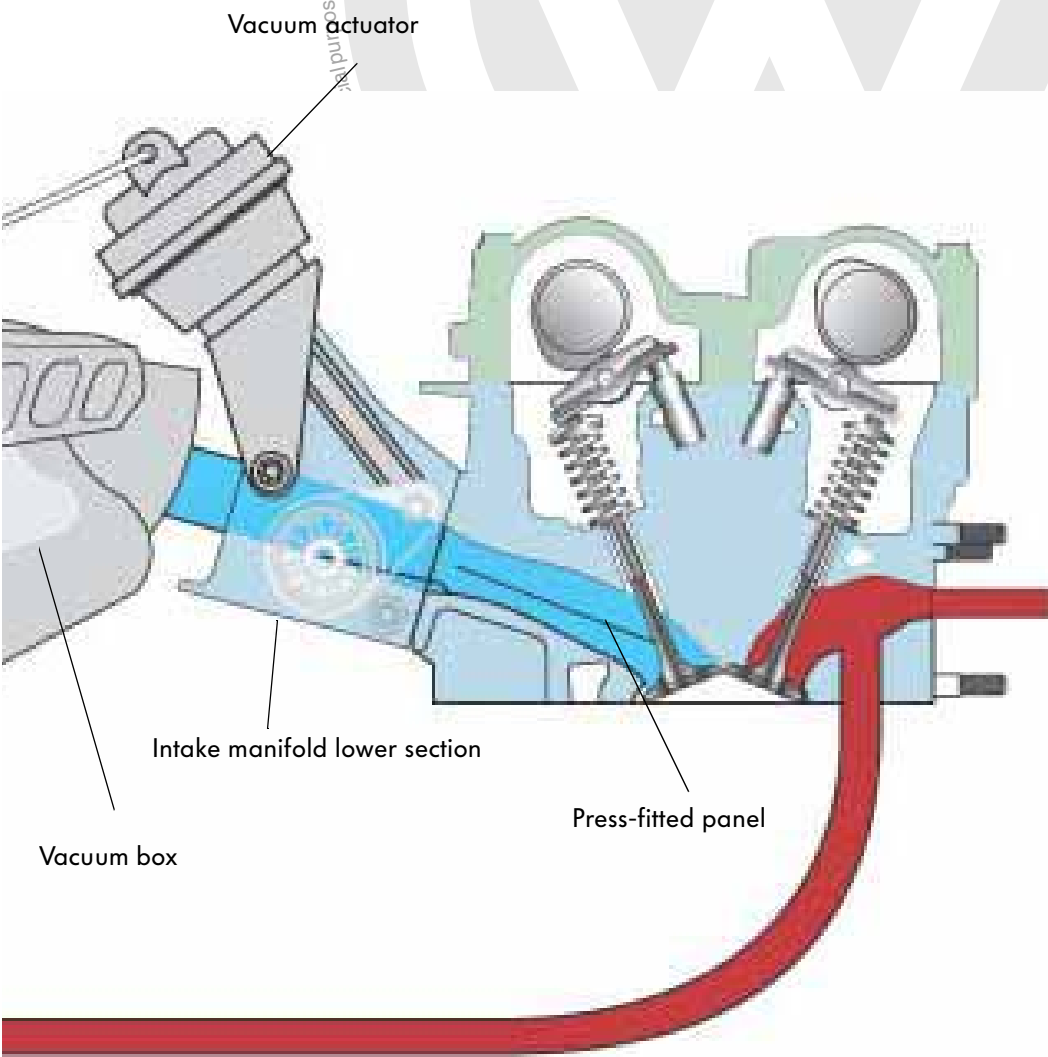

Engine management system

Intake manifold flap changeover mechanism

The engine management system allows the air flow in the cylinders to be controlled depending on operating point.

The engine management system consists of:

- a non-return valve
- a vacuum box in the intake manifold
- an intake manifold flap valve
- a vacuum actuator
- four intake manifold flaps in the intake manifold lower section
- an intake manifold flap potentiometer
- the press-fitted panels in the cylinder head

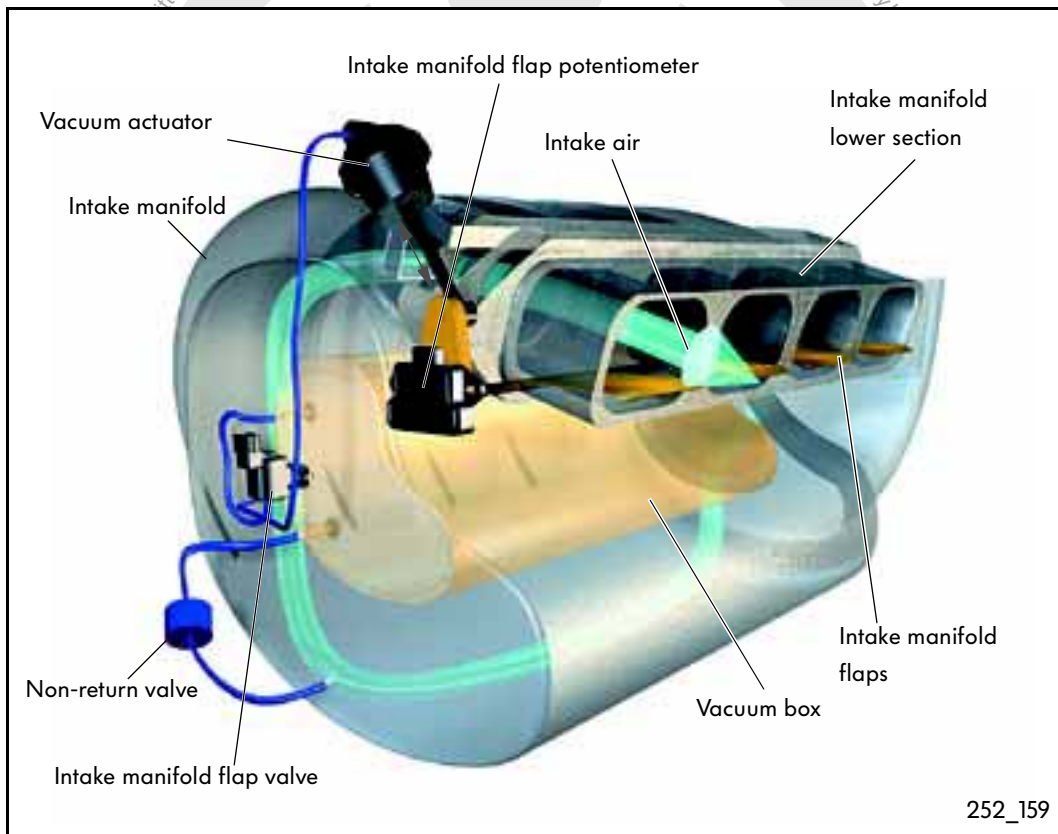

Function

A vacuum builds up in the intake manifold when fresh air is induced. Because the vacuum box and the intake path are directly interconnected, a vacuum also develops in the intake path.

The non-return valve maintains the vacuum in the vacuum box after the engine is turned off.

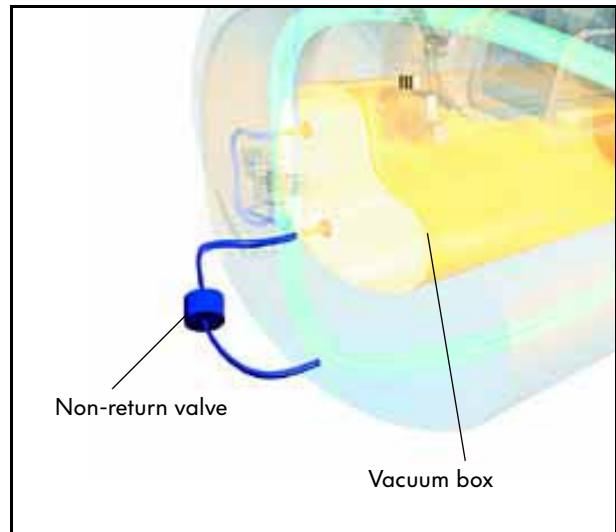

252_157

The intake manifold flap valve is located on the vacuum box. It is activated by the engine control unit and switches the vacuum from the vacuum box through to the vacuum actuator of the intake manifold flap. The vacuum actuator in turn actuates the intake manifold flap.

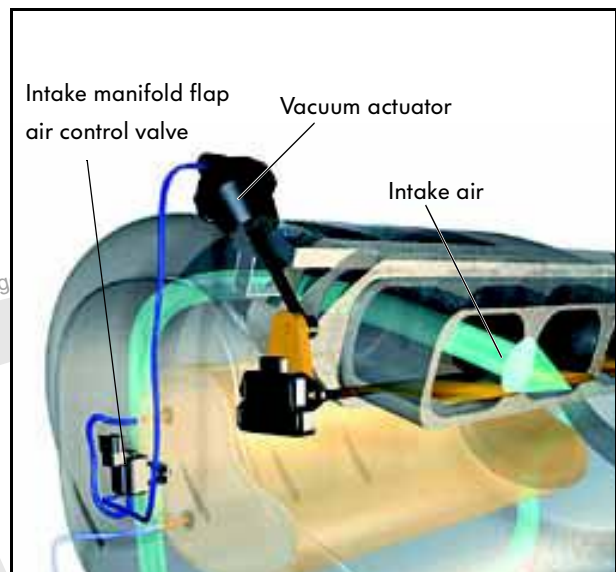

252_158

Because the position of the intake manifold flap affects mixture formation, and hence also emission levels, diagnosis of the intake manifold flaps must be performed. The diagnosis procedure is performed by the intake manifold flap potentiometer.

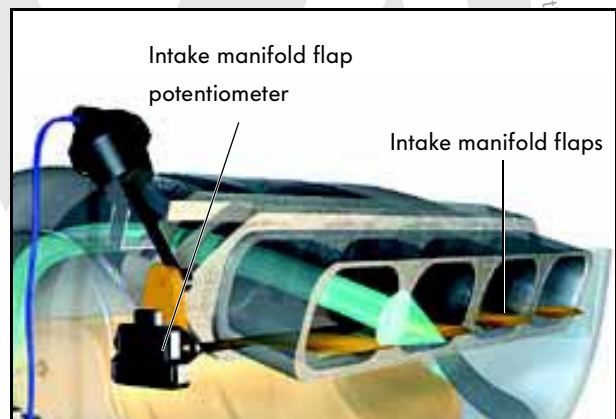

252_158



Engine management system

Intake manifold flap actuated

In stratified charge mode and, in part, in homogeneous mode, the intake manifold flap is actuated and the lower duct in the cylinder head is closed. As a result, the intake air only flows along the narrow upper duct, increasing the flow rate. In addition, the upper duct is designed in such a way that the intake air tumbles into the cylinder.

The tumble air flow has the following effects:

- In stratified charge mode, the fuel is channelled to the spark plug. The fuel/air mixture forms as the fuel flows towards the spark plug.
- Mixture formation supported in several operating ranges in homogeneous mode. The movement of the charge ensures a highly ignitable fuel/air mixture and stable combustion.

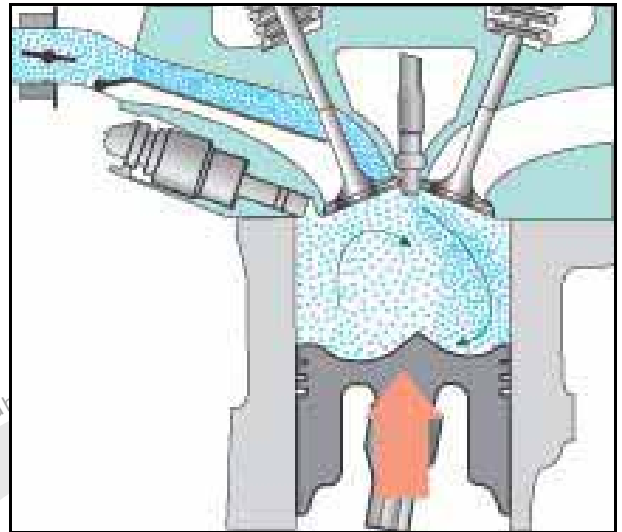

252_019

Intake manifold flap not actuated

In homogeneous mode, the intake manifold flap is not actuated under high engine load, and the two ducts are open.

By virtue of the larger cross-section of the intake duct, the engine is able to draw in the air mass required to generate produce high engine torque.

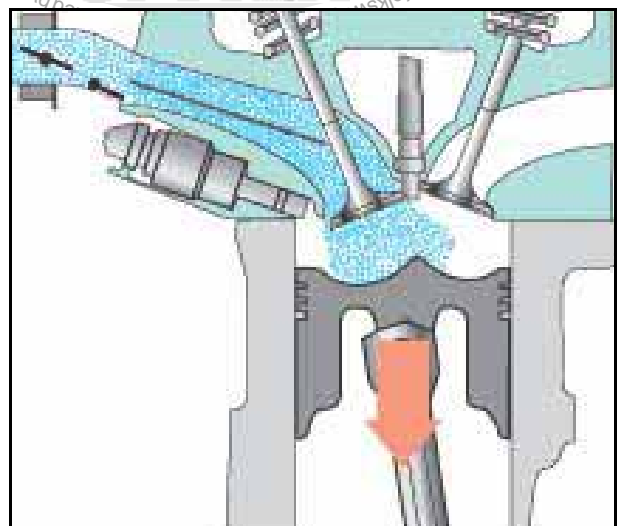

252_023

Intake manifold flap potentiometer G336

Fitting location

It is attached to the intake manifold lower section and connected to the shaft for the intake manifold flaps.

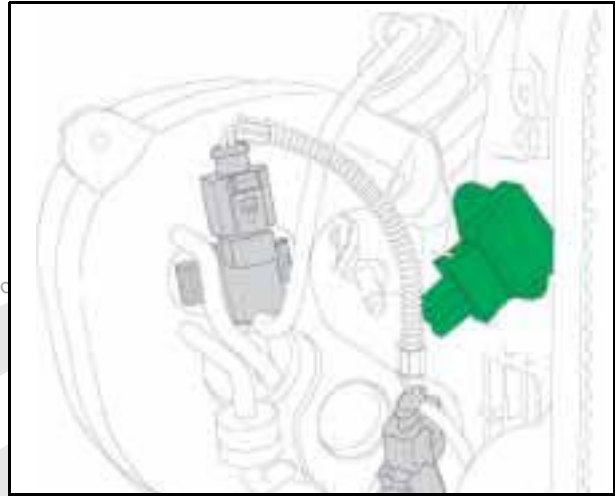

Task

The intake manifold flap potentiometer recognises the position of the intake manifold flap and sends this information to the engine control unit. This is necessary because the intake manifold flap changeover mechanism affects ignition, residual gas concentration and

pulsation in the intake manifold. The position of the intake manifold flap is therefore relevant to exhaust emissions and must be checked by the self-diagnosis.

252_166

Intake manifold flap air flow control valve N316

Fitting location

It is attached to the intake manifold.

Task

The intake manifold flap air flow control valve is activated by the engine control unit and opens the path from the vacuum reservoir to the vacuum actuator. The intake manifold flaps are then actuated by the vacuum actuator.

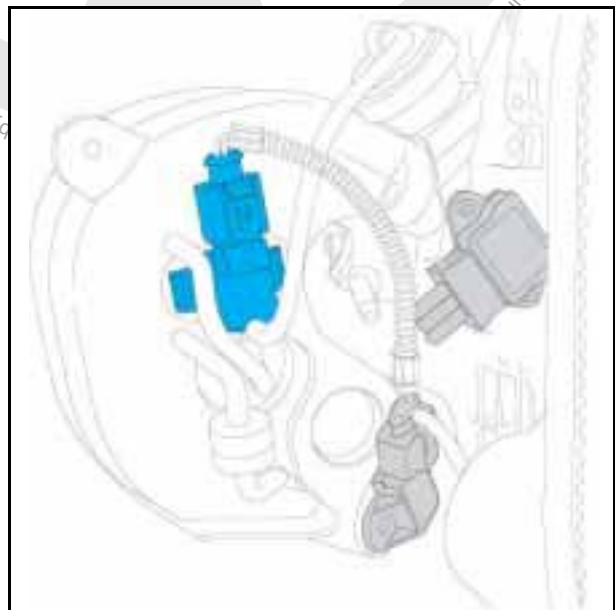

252_165



Engine management system

Air-mass flow meter G70 with intake air temperature sender G42

Fitting location

The two sensors are a single component and are located in the intake path upstream of the throttle valve control unit.

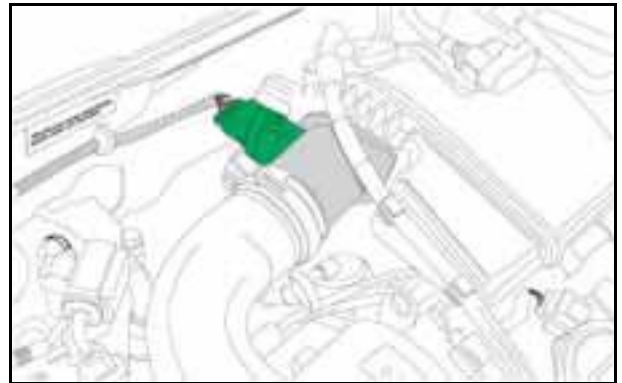

Task

252_164

To obtain as exact an engine load signal as possible, an engine air-mass flow meter with reverse flow recognition is used. This device measures not only the air volume which is drawn in; it also recognises how much air flows back when the valves are opened and closed. This

enables the engine control unit to accurately determine air mass intake, and hence engine load.

The intake air temperature is used for exact air mass determination (for further information, refer to SSP 195).

Intake manifold pressure sender G71

Fitting location

It is attached to the intake manifold.

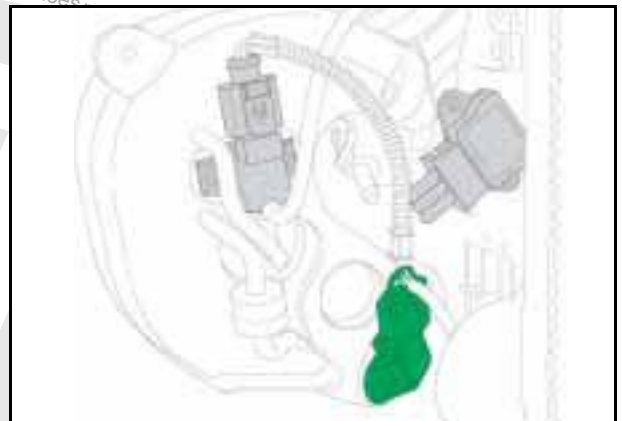

Task

252_167

The intake manifold pressure sender gauges the pressure inside the intake manifold and sends a corresponding signal to the engine control unit. The engine control unit uses this signal to compute the exhaust gas recirculation rate. From the information supplied by the hot-film air mass meter, the engine control unit knows how much fresh air was induced and, accordingly, how high the intake manifold pressure is required to be. If exhaust gases are admitted, however, the actual

intake manifold pressure rises. The engine control unit calculates the exhaust gas recirculation rate from this differential between the intake manifold pressure (fresh air) and the intake manifold pressure (fresh air + exhaust gas).

The exhaust gas recirculation rate can consequently be increased, because a large margin of safety to the operating limit is not required.

Brake servo pressure sensor G294

Fitting location

It is located in the line between the intake manifold and the brake servo.

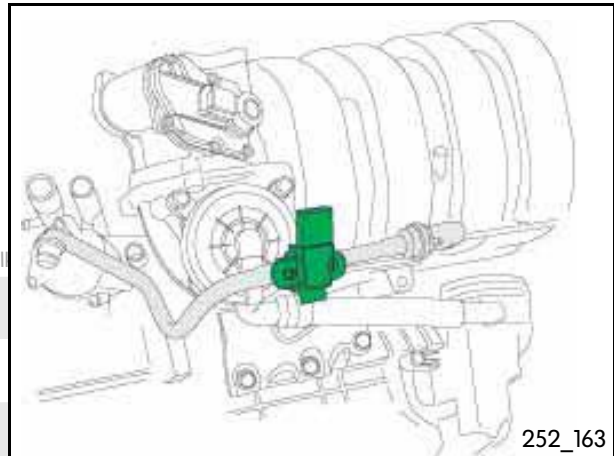

Task

The brake servo pressure sensor gauges the pressure in the line, and hence the pressure in the brake servo. A corresponding voltage signal is sent to the engine control unit. The engine control unit determines whether sufficient vacuum is available for the brake servo. This is necessary because the throttle valve is wide open in stratified charge mode, and consequently there is very little vacuum inside the intake manifold. If the driver now operates the brake several times in succession, the vacuum accumulated in the brake servo will no longer be sufficient. In this case, the driver would have to apply more pressure to the brake. To prevent this, the throttle valve is closed until vacuum is again sufficient to operate the brake servo.

In an emergency, the vehicle changes over to homogeneous mode.



Engine management system

Fuel system

The fuel system is divided into a low-pressure fuel system and a high-pressure fuel system.

In the low pressure fuel system,
the fuel pressure is 3 bar during normal operation and max. 6.8 bar during a hot start.

It comprises:

- the fuel tank
- the electrical fuel pump (G6)
- the fuel filter
- the fuel metering valve (N290)
- the fuel pressure regulator
- the activated charcoal canister system

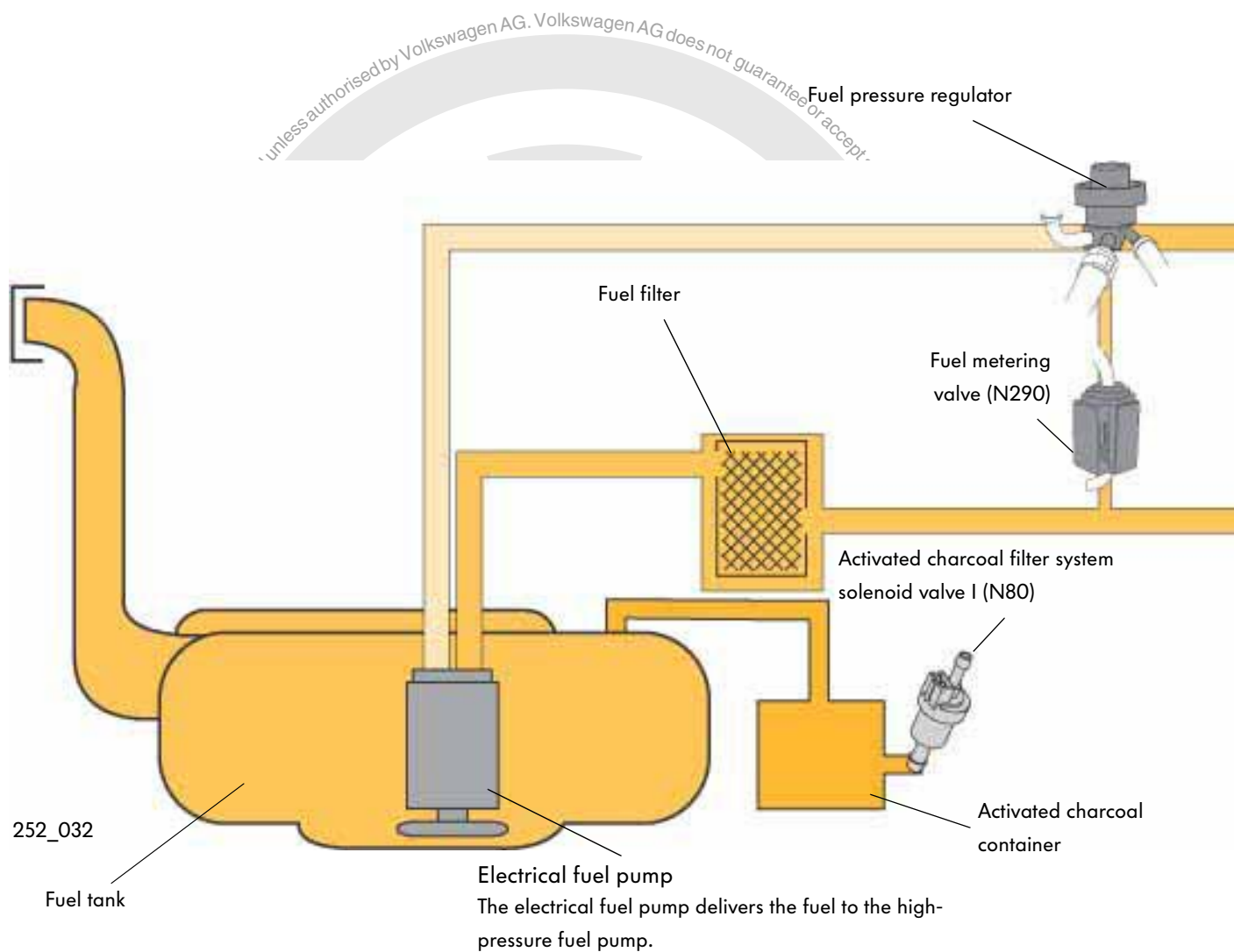

In the high-pressure fuel system,
the fuel pressure is between 50 and 100 bar,
depending on the characteristic map.

It comprises the following components:

- the high-pressure fuel pump
- a high-pressure fuel line
- the fuel manifold
- the fuel pressure sender (G247)
- the fuel pressure regulating valve (N276)
- the high-pressure injectors (N30-N33)

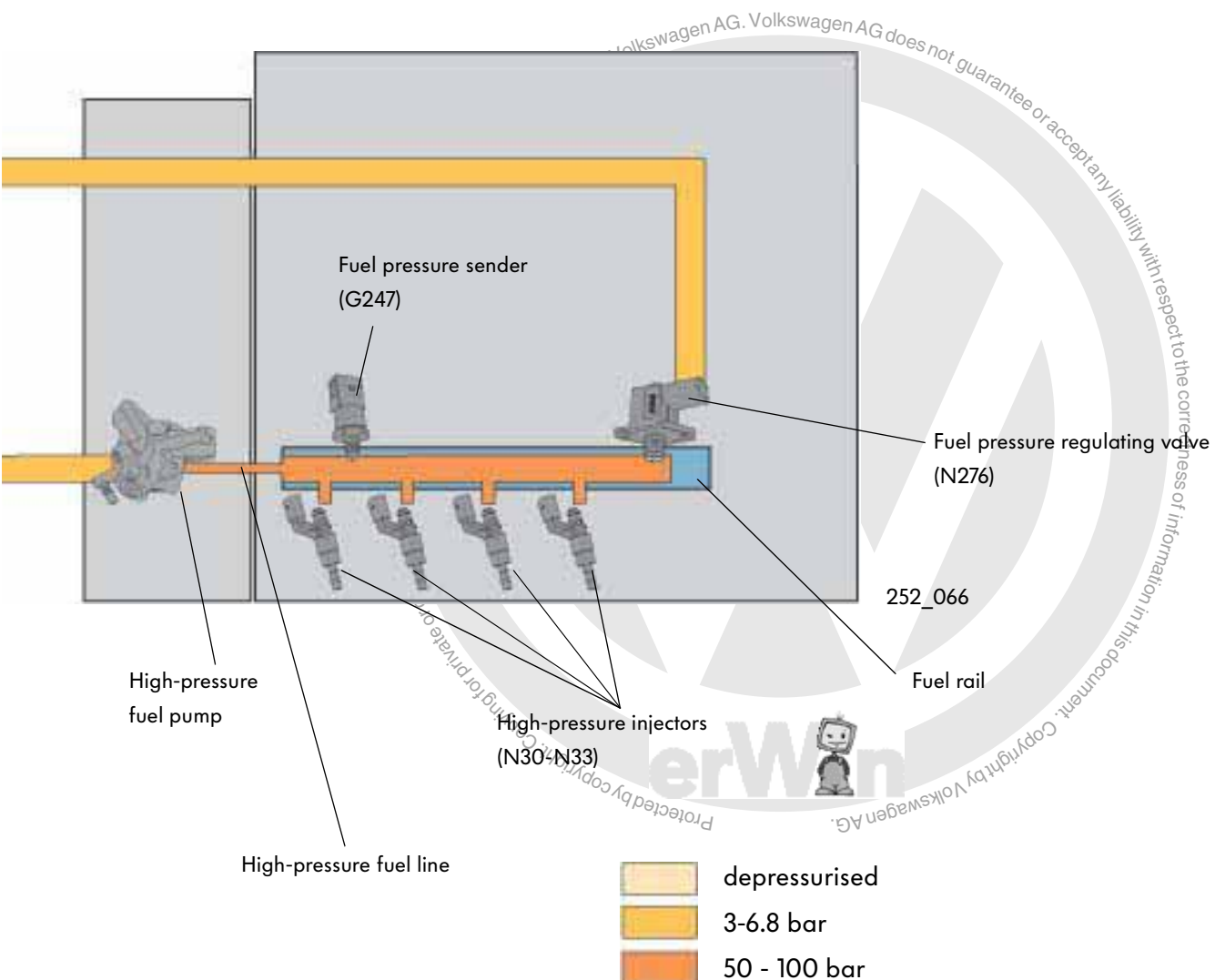

Engine management system

The fuel pressure regulator

is located on the suspension strut tower. It sets the fuel pressure in the low pressure fuel system to 3 bar by means of a spring-loaded diaphragm valve. In the process, the cross-section to the fuel return line is enlarged or reduced as a function of pressure.

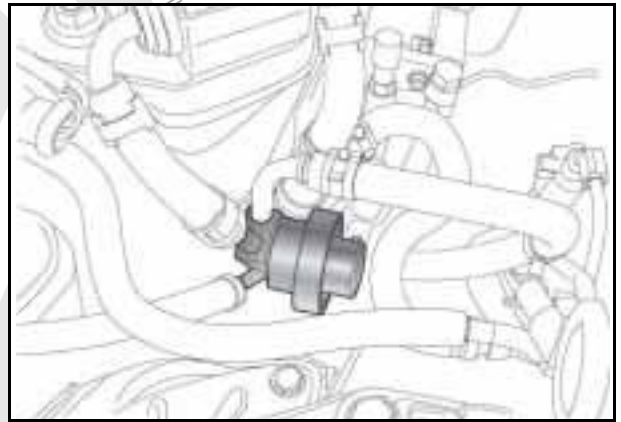

252_060

The fuel metering valve (N290)

is attached to the suspension strut tower.

During normal operation, the valve is permanently open and releases the return line to the fuel pressure regulator.

If

- the coolant temperature is higher than 115°C and
- the intake air temperature is higher than 50°C,

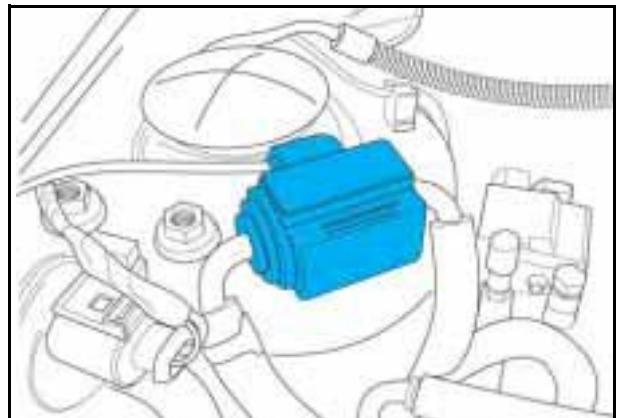

252_061

at engine start-up, then the engine control unit closes the valve for approx. 50 seconds. As a result, the path to the fuel return line is blocked on the suction side of the high-pressure fuel pump. The pressure in the low pressure fuel system now rises to the maximum feed pressure of the electrical fuel pump. Max. feed pressure is governed by a pressure limiting valve in the fuel pump, and must not exceed 6.8 bar.

This pressure increase prevents vapour bubble formation on the suction side of the high-pressure fuel pump and ensures correct high-pressure build up.

The high-pressure fuel pump

is attached to the camshaft housing.

It is a 3-cylinder radial piston pump and is driven by the inlet camshaft. It pumps the fuel along a high-pressure fuel line to the fuel manifold. The high-pressure fuel pump increases the pressure from the low pressure fuel system from 3 bar to approximately 100 bar. The pressure in the fuel manifold is set via the fuel pressure regulating valve.

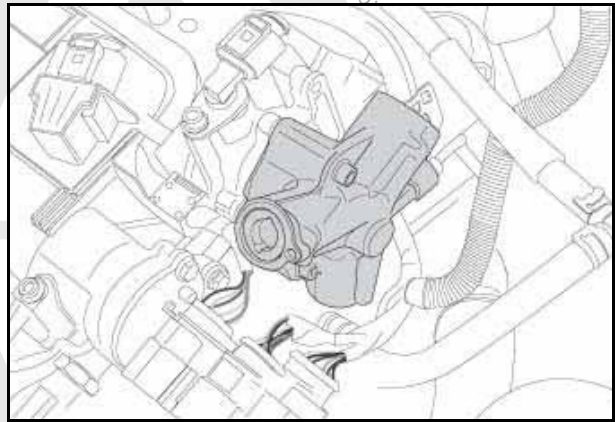

252_162

The fuel manifold

is integrated in the intake manifold lower section.

The task of the fuel manifold is to store the fuel under high pressure and distribute it via the high-pressure injectors to the individual cylinders.

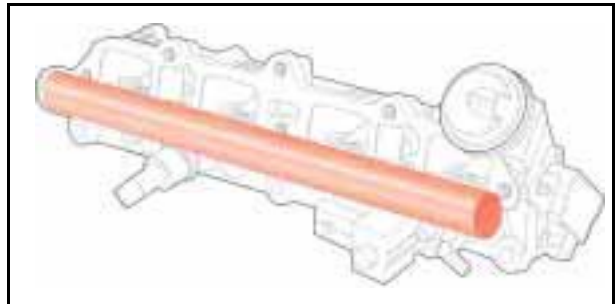

252_064

The fuel pressure sender (G247)

is located on the intake manifold lower section and is screwed into the fuel manifold.

It gauges the momentary fuel pressure in the fuel manifold and sends this information to the engine control unit in the form of a voltage signal. Regulation of the fuel pressure in the fuel manifold then commences.

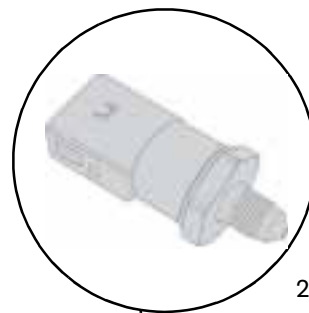

252_052

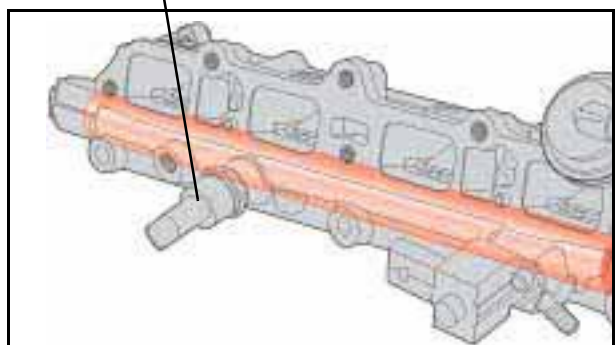

252_048



Engine management system

The fuel pressure regulating valve (N276)

is screwed into the intake manifold lower section in the fuel manifold.

The regulating valve regulates the fuel pressure in the fuel manifold between 50 and 100 bar. It is pulse-actuated by the engine control unit, and sets the pressure in the fuel manifold in accordance with discharge quantity.

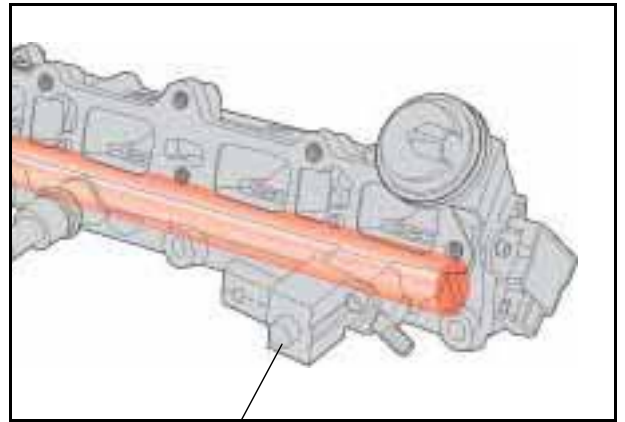

252_048

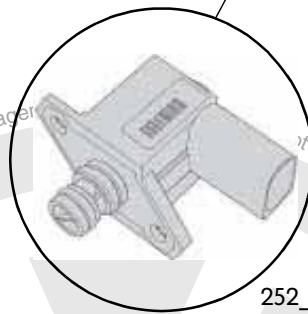

252_053

The high-pressure injectors (N30-33)

are positioned in the cylinder head and inject fuel directly into the combustion chamber.

The injectors are single-hole injectors; the jet angle is 70° and the angle of inclination of the jet is 20° .

The injectors are also adapted to the requirements of a petrol-direct injection engine. These are, firstly, the higher fuel pressure and, secondly, the reduced amount of time available to the injection cycle in stratified charge mode.

The injectors are sealed off from the combustion chamber by a Teflon sealing ring.

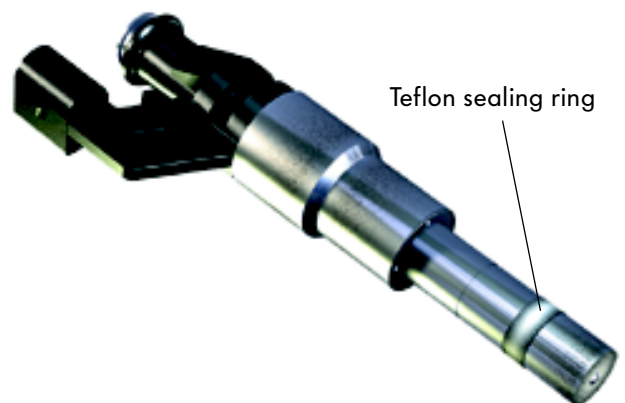

252_100

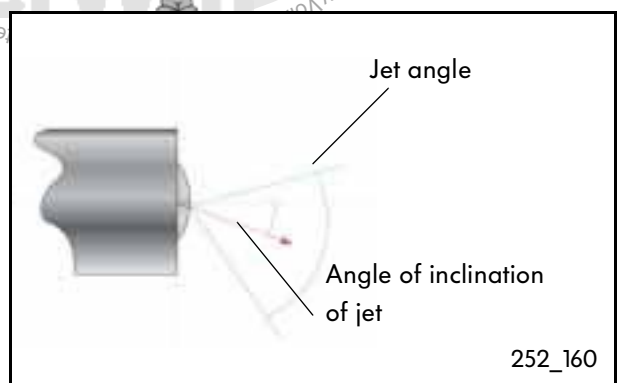

252_160

The exhaust system

was adapted to the requirements of a petrol-direct injection engine.

The exhaust gas aftertreatment was previously a major problem for direct-injection petrol engines. This is due to the fact that the statutory nitrogen oxide limits are not achievable with a three-way catalytic converter in lean stratified charge mode. An NO_x storage catalytic converter, which stores the nitrogen oxides in

stratified charge mode, is therefore fitted in this engine. If all storage spaces are full, the engine control unit changes over to homogeneous mode. In the process, the nitrogen oxides are extracted from the catalytic converter and converted to nitrogen. In homogeneous mode at $\lambda = 1$, the NO_x storage catalytic converter operates in much the same way as a conventional three-way catalytic converter.

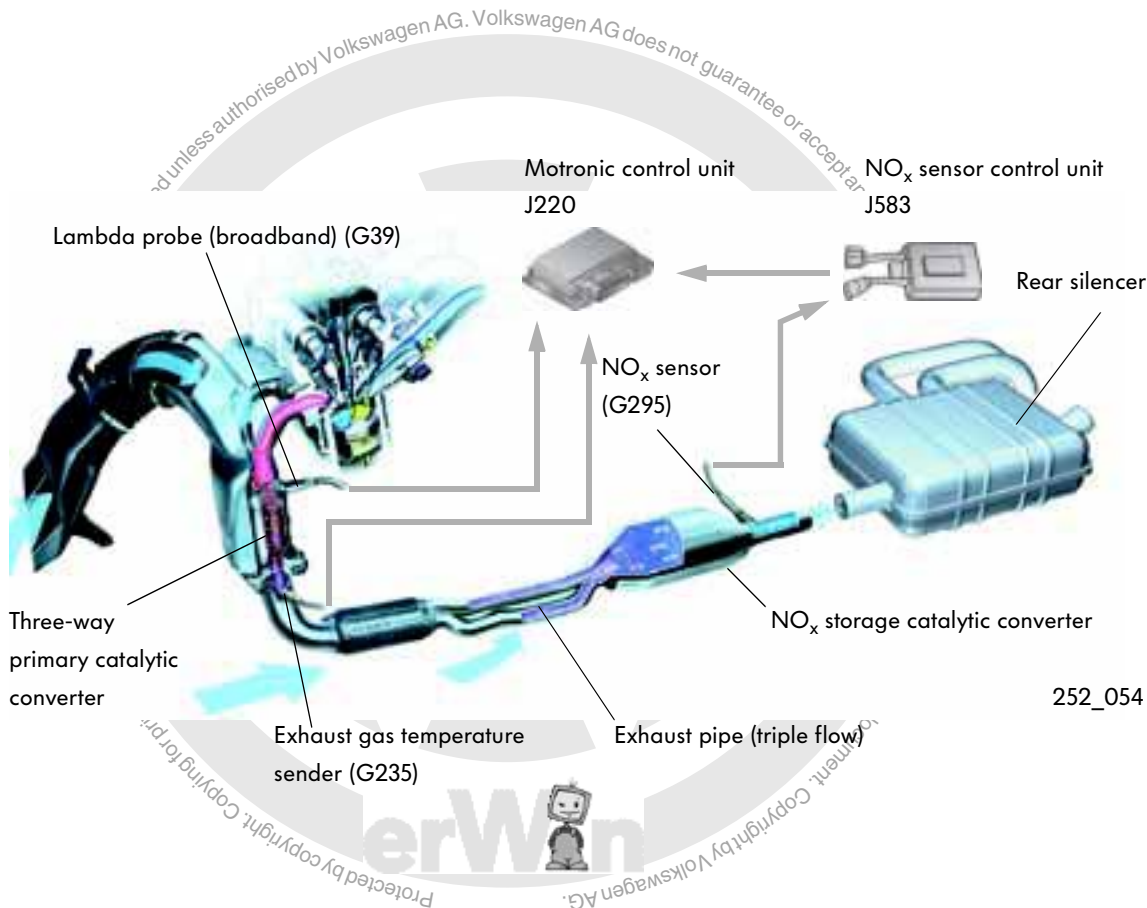

The exhaust system comprises the following components:

- an exhaust manifold with three-way primary catalytic converter
- an air duct on the exhaust manifold
- a triple flow exhaust pipe
- an NO_x storage catalytic converter
- a broadband lambda probe (G39)
- an exhaust gas temperature sender (G235)
- an NO_x sensor (G295)
- an NO_x sensor control unit (J583)
- a rear silencer

Engine management system

Exhaust gas cooling system

The NO_x storage catalytic converter can only store nitrogen oxides (NO_x) within a temperature range between 250°C and 500°C. The exhaust gas is cooled so that it is in this temperature range as often and long as possible. The exhaust gas is cooled firstly by an exhaust manifold cooling system and, secondly, by a triple flow exhaust pipe.

Exhaust manifold cooling system

Fresh air is directed to the exhaust manifold at the front end of the vehicle and thus the exhaust gas is cooled.

As a result, it is possible to change over to the consumption-optimised stratified charge mode as quickly as possible after trips involving high exhaust gas temperatures.

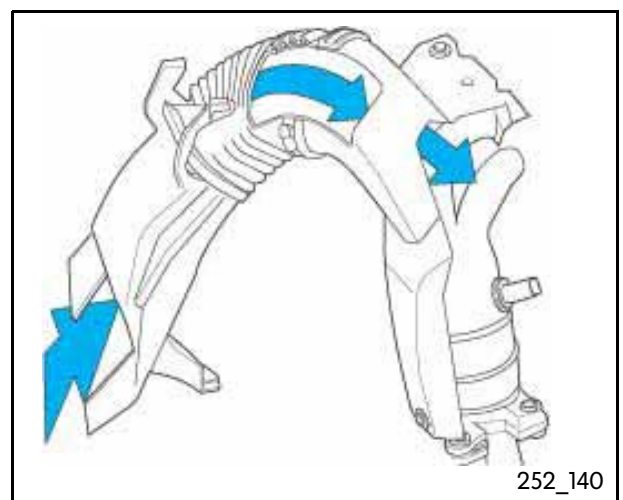

The triple flow exhaust pipe

is located upstream of the NO_x storage catalytic converter. It also serves to reduce the temperature of the exhaust gases and NO_x storage catalytic converter. Its larger surface area increases heat dissipation to the atmosphere and reduces the exhaust gas temperature.

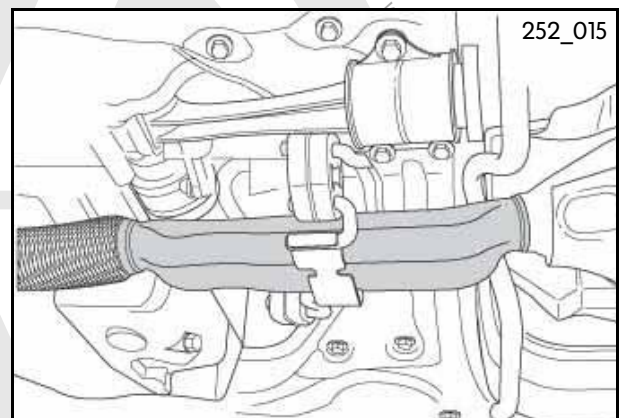

Temperature sensor

Fitting location

The temperature sensor is located downstream of the primary catalytic converter.

Task

It gauges the exhaust gas temperature and sends this information to the engine control unit. The engine control unit calculates the temperature in the NOx storage catalytic converter from this information.

This is necessary because:

- the NOx storage catalytic converter can only store nitrogen oxides at temperatures between 250°C and 500°C. For this reason, stratified charge mode may only be selected in this temperature range.
- the sulphur from the fuel is also collected involuntarily in the NOx storage catalytic converter. To extract the sulphur again, the temperature in the storage catalytic converter must rise above 650°C.

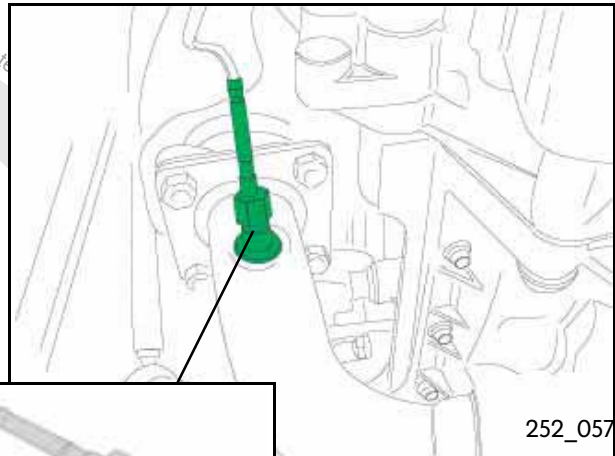

Broadband lambda probe (primary catalytic converter)

Fitting location

It is located on the exhaust manifold.

Task

Using the broadband lambda probe, the oxygen content in the exhaust gas can be defined over a wide measurement range.

In the event of deviations from the setpoint, the injection time is corrected.

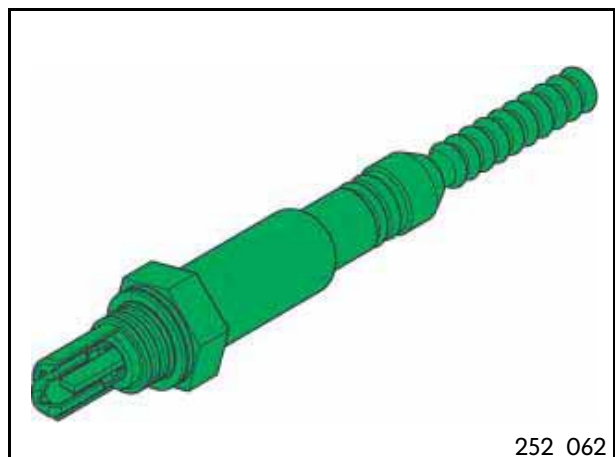

Engine management system

The primary catalytic converter

is a three-way catalytic converter and is located in the exhaust manifold.

This near-engine layout is necessary so that the catalytic converter can reach its operating temperature and exhaust gas treatment can begin as quickly as possible. This is the only way to achieve the strict exhaust emission limits.

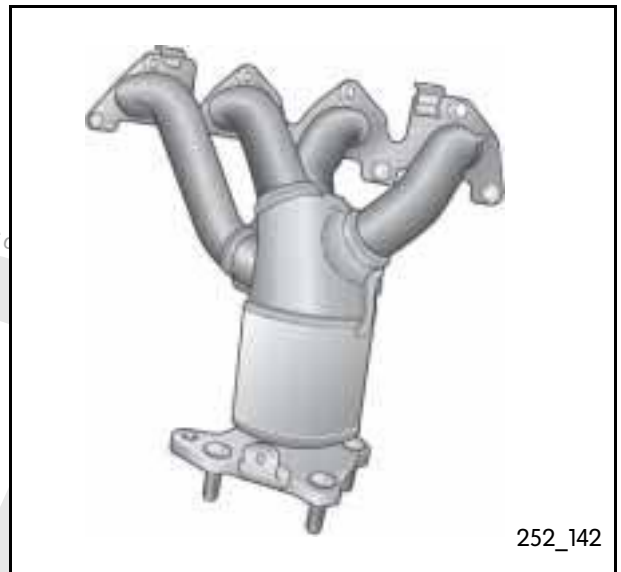

The NO_x storage catalytic converter

has a similar mechanical construction to a conventional three-way catalytic converter. However, barium oxide was added to the converter. Barium oxide stores nitrogen oxides at temperatures between 250°C and 500°C by forming nitrates.

This is necessary because a three-way catalytic converter can only convert a small proportion of the nitrogen oxides into nitrogen in lean stratified charge mode.

The engine control unit detects when the storage spaces are full and changes over to regeneration mode.

This is the only way to maintain the exhaust emission limits.

For further information regarding regeneration mode, refer to pages 44 and 45.

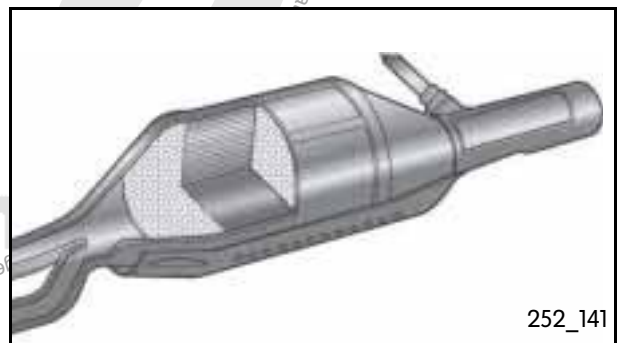

Due to its chemical similarity with nitrogen oxides, the sulphur contained in the fuel is also stored as a sulphate. Because of this, it occupies the storage spaces of the nitrogen oxides and requires to be frequently regenerated.

NOx sensor

Fitting location

It is located downstream of the NOx storage catalytic converter.

Task

The NOx sensor is used to determine the nitrogen oxide (NOx) and oxygen content in the exhaust gas according to the functional principle of a broadband lambda probe.

- The remaining storage capacity of the NOx storage catalytic converter is determined on the basis of nitrogen oxide content.
- Oxygen content is still used to monitor the functioning of the catalytic converter and adapt the injection quantity if necessary.

The signals are transmitted from the NOx sensor to the NOx sensor control unit.

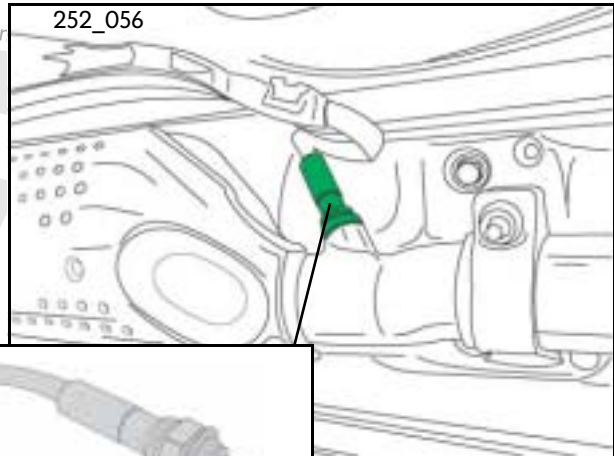

NOx sensor control unit

Fitting location

It is located on the vehicle underbody near to the NOx sensor. The layout near to the engine prevents external interference falsifying the signals of the NOx sensor.

Task

In the NOx sensor control unit, the signals are processed and sent to the engine control unit. If the engine control unit recognises that the storage capacity of the NOx storage catalytic converter is exhausted, it changes over to regeneration mode.

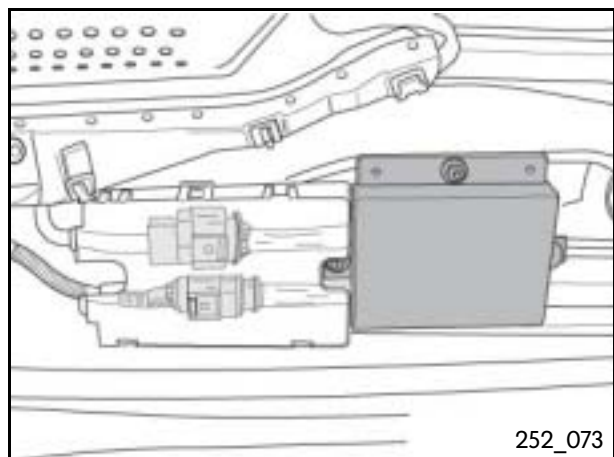

Engine management system

Regeneration mode

In this mode, the stored nitrogen oxides and the sulphur are extracted from the NO_x storage catalytic converter and converted to harmless nitrogen or sulphur dioxide.

Nitrogen oxides

Nitrogen oxides are regenerated when the nitrogen oxide concentration downstream of the storage catalytic converter exceeds a defined limit value. This tells the engine control unit that the catalytic converter can no longer store nitrogen oxides and storage capacity is exhausted. The regeneration mode is activated.

At the same time, the engine management system changes over from the lean stratified charge mode to the homogeneous mode, thereby increasing the hydrocarbon and carbon monoxide content in the exhaust gas. In the storage catalytic converter, the hydrocarbons and the carbon monoxide combine with the oxygen of the nitrogen oxides, and produce nitrogen from the nitrogen oxides.

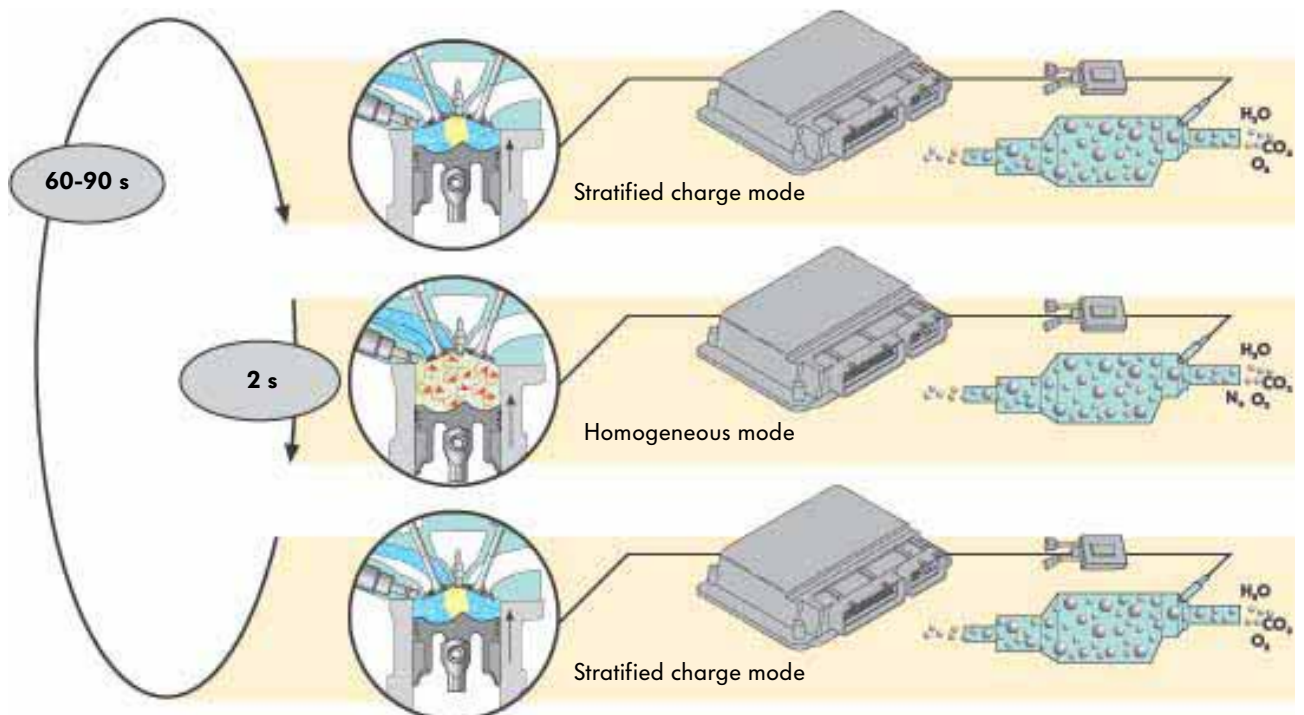

252_151

In stratified charge mode, the NO_x storage catalytic converter can store nitrogen oxides for between 60 and 90 seconds. This is followed by a 2-second regeneration cycle.

Sulphur regeneration

The regeneration of sulphur is slightly more complex because the sulphur is more temperature resistant and remains stored in the catalytic converter during the nitrogen oxide regeneration cycle. The fuel is desulphurised if the nitrogen oxide concentration downstream of the NOx storage catalytic converter reaches a defined value within ever-decreasing time intervals. From this, the engine control unit concludes that the memory locations of the catalytic converter are free from sulphur and the nitrogen oxides can no longer be stored.

The fuel desulphurisation cycle takes approx. 2 minutes, whereby:

- the engine management system changes over from stratified charge mode to homogeneous mode and
- the temperature of the storage catalytic converter is increased to above 650°C by adjusting the ignition timing towards "retard".

Only then is the stored sulphur converted to sulphur dioxide SO₂.

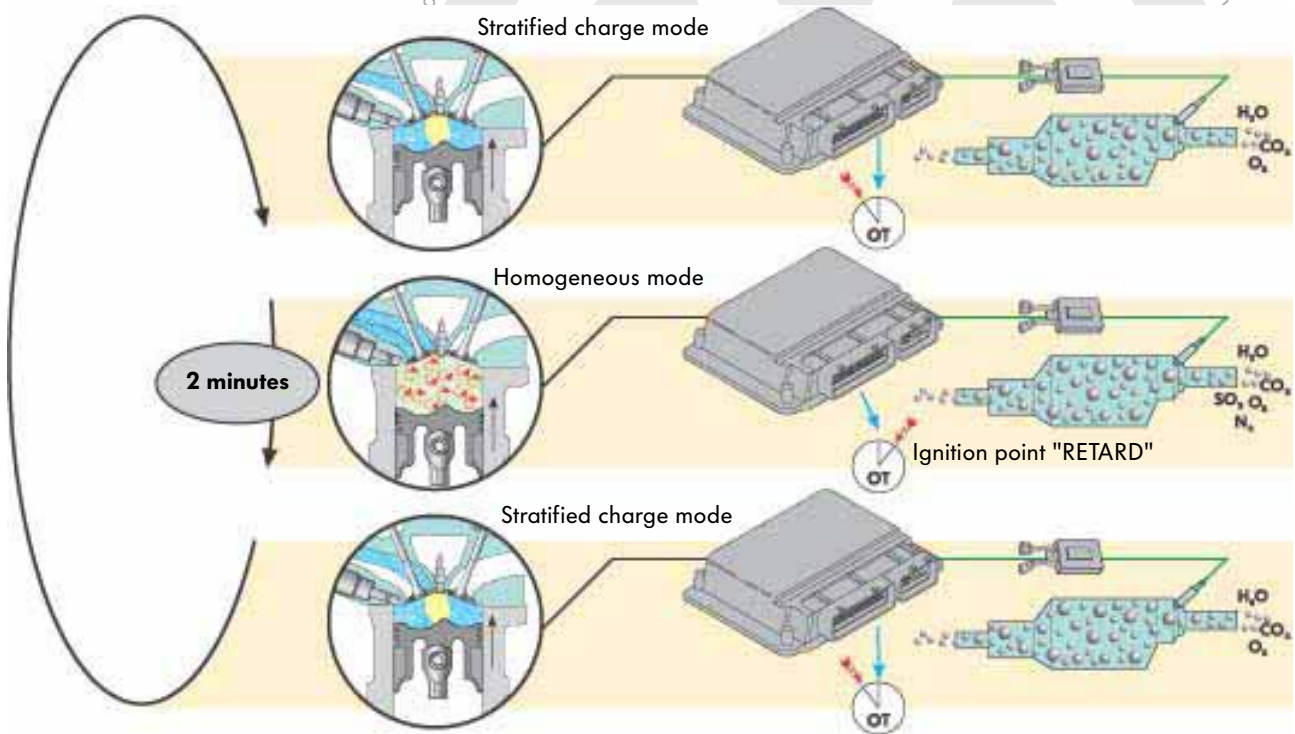

252_152

Trips involving high engine load and engine speed lead automatically to desulphurisation because the necessary desulphurisation temperature is reached in the NOx storage catalytic converter.



To minimise fuel consumption by sulphur regeneration, a sulphur-free fuel (Shell Optimax) was developed by Shell in association with Volkswagen. With RON 99, Shell Optimax offers the following advantages:

- lower fuel consumption because fewer sulphur regeneration cycles are needed,
- reduced pollutant emissions through a new processing method and sulphur elimination,
- improved acceleration due to higher octane number (RON 99) and
- fewer deposits in the engine through special fuel additives.



Engine management system

Exhaust gas recirculation system

This justifies the use of a NO_x storage catalytic converter. This is because the incoming exhaust gases reduce combustion temperature and nitrogen oxide formation.

Exhaust gas recirculation is performed

- continuously in stratified charge mode and
- up to an engine speed of 4000 rpm and at medium engine load in homogeneous mode, but not when the engine is running at idling speed.

The recirculated exhaust gas quantity is max. 35% of the total amount of gas induced.

As a result, the catalytic converter is able to store nitrogen oxides over a longer period of time and does not required to be regenerated as often.

The vehicle can be operated in the fuel-saving stratified charge mode for longer.

The exhaust gas recirculation valve (N18)

is attached to the intake manifold by bolts. It was redesigned to allow high exhaust gas recirculation rates.

It comprises a housing with:

- a throttle valve,
- an electric motor and
- the exhaust gas recirculation potentiometer (G212).

The exhaust gases are extracted via a connecting tube on the head of the fourth cylinder.

The engine control unit activates the electric motor depending on the characteristic map and actuates a throttle valve.

Depending on throttle valve position, a defined quantity of exhaust gas now flows into the intake manifold and mixes with the fresh air induced.

The exhaust gas recirculation potentiometer in the housing cover recognises the position of the throttle valve. This allows the exhaust gas recirculation valve to be diagnosed.

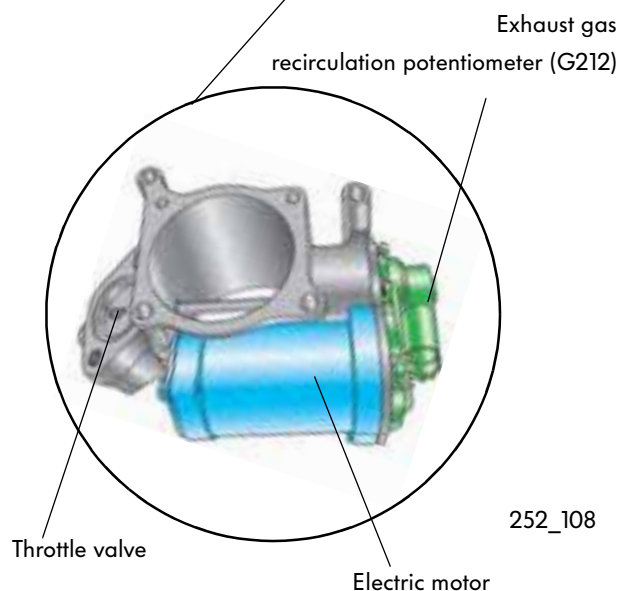
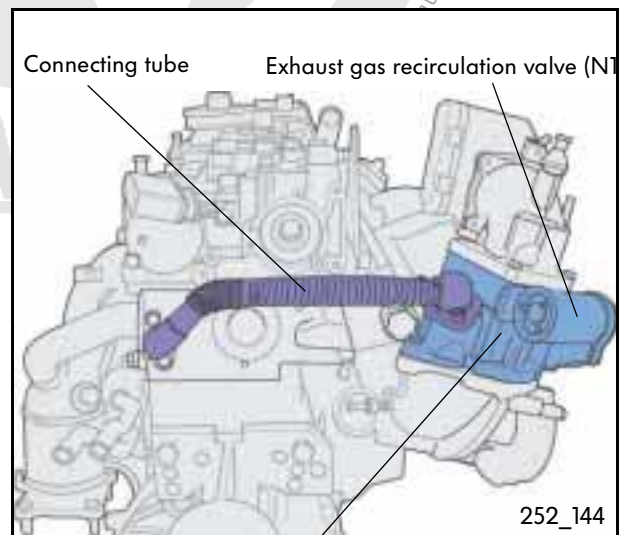

Rear silencer

The rear silencer has a valve which adjusts the cross-section through which the exhaust gas flows depending on the exhaust gas backpressure level. The backpressure, in turn, is dependent on engine speed and engine load.

The advantages of this valve are:

- noise emissions are low at low engine speed and engine load
- maximum engine power output is achieved at high engine speed and full engine load



252_156

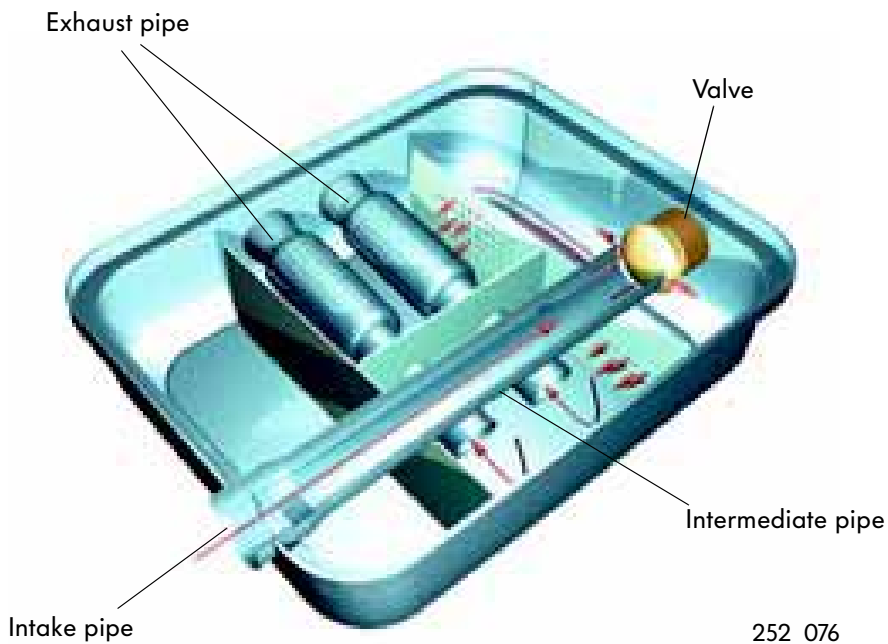

252_076



Engine management system

Mode of operation

At low engine speeds and low engine load or in overrun mode,

The back pressure in the exhaust is low and the valve is nearly closed. As a result, the exhaust gas only flows through a small cross-section, and an exhaust backpressure builds up at the valve plate. This backpressure causes the sound waves of the exhaust gas to be compressed more densely and leads to a more uniform noise pattern. In addition, the sound waves are reflected against the valve plate and combine with the approaching sound waves. The likewise reduces noise emissions.

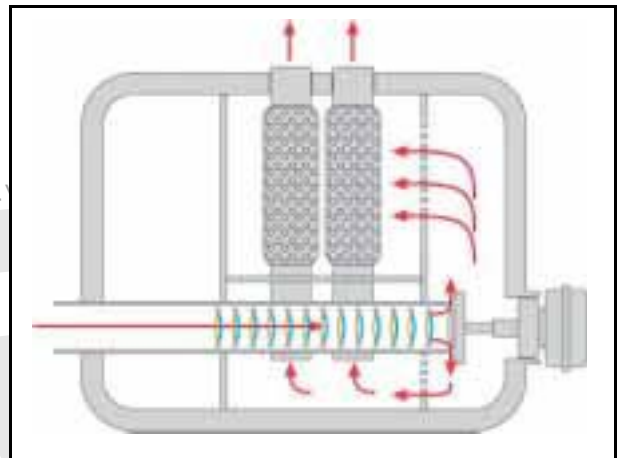

252_099

- (= arriving sound waves
-) = reflected sound waves

At increasing engine speed and engine load,

the backpressure at the valve plate rises, too. The valve is opened further and the cross-section is enlarged as a result.

At high engine speeds and at full throttle

As of engine speeds of approx. 3000 rpm and at full throttle, the valve is fully open and the whole cross-section is released. This minimises backpressure and allows the exhaust gases to bypass the valve plate almost unobstructed. The engine produces its full power output.

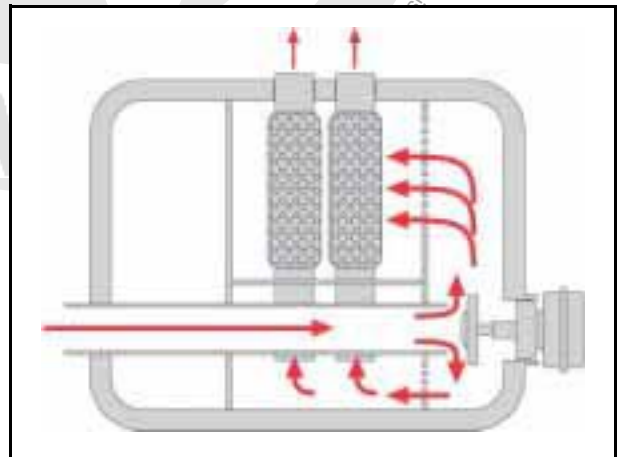

252_103

Cooling system depending on

The 1.4-litre 77kW engine has an electronically controlled cooling system. This system adjusted the coolant temperature to between 85°C and 110°C depending on the characteristic map.

In the part-throttle range,

the coolant temperature is between 95°C and 110°C. The engine oil consequently becomes warmer and has a lower viscosity. This reduces friction and fuel consumption.

In the full-throttle range,

the coolant temperature is reduced to between 85°C and 95°C. The lower temperature level means that the induced air does not heat up as much, and the engine produces higher power output and torque.

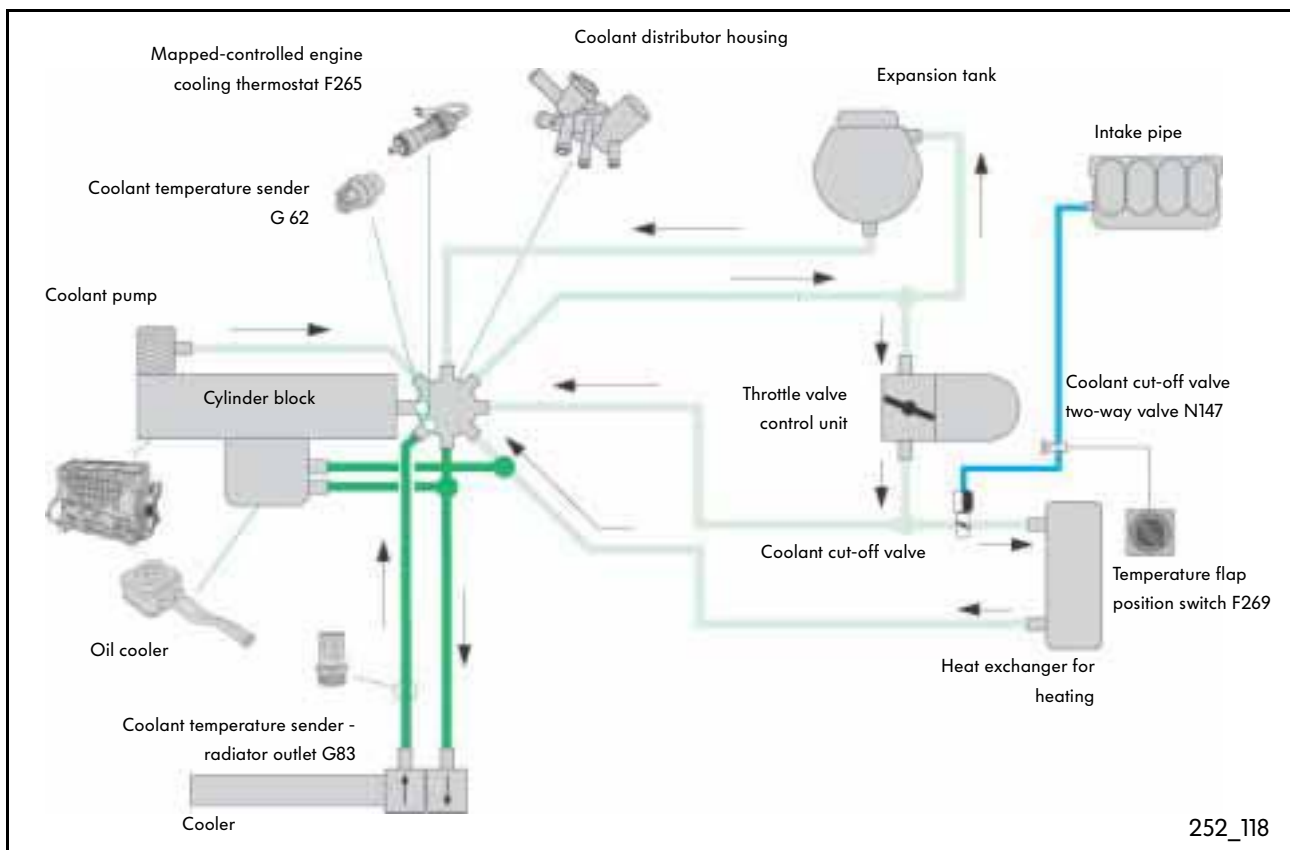

The temperature in the cooling system is dependent on the coolant quantity which flows through the radiator and is cooled here. The quantity of coolant is defined by the mapped-

controlled engine cooling thermostat. Depending on temperature, the cross-section leading from the radiator to the coolant distributor housing is enlarged or reduced.



For further information, please refer to Self-Study Programme "Electronically controlled cooling system" (No. 222).

Engine management system

Function diagram

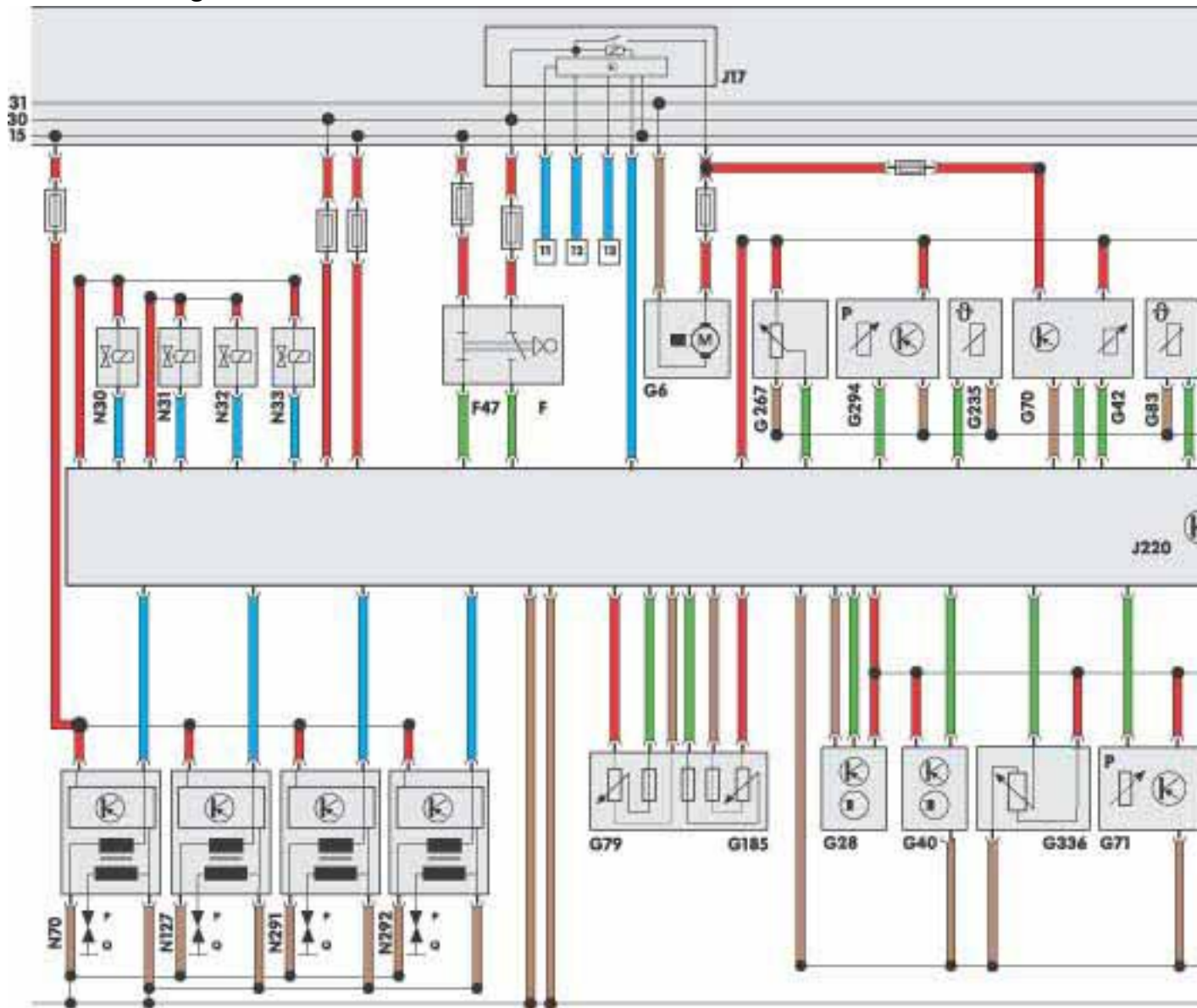

252_104

- | | | | |
|-------------|---|-------------|---|
| F | Brake light switch | G83 | Coolant temperature sender - radiator outlet |
| F47 | Cruise cont. sys. brake pedal switch | G185 | Accelerator pedal position sender -2- |
| F63 | Brake pedal switch | G186 | Throttle valve drive |
| F265 | Mapped-controlled engine cooling thermostat | G187 | Throttle valve drive angle sender -1- |
| | | G188 | Throttle valve drive angle sender -2- |
| G2 | Coolant temperature sender | G212 | Exhaust gas recirculation potentiometer |
| G6 | Fuel pump | G235 | Exhaust gas temperature sender -1- |
| G28 | Engine speed sender | G247 | Fuel pressure sender |
| G39 | Lambda probe | G267 | Rotary knob temperature selection potentiometer |
| G40 | Hall sender | G294 | Brake servo pressure sensor |
| G42 | Intake air temperature sender | G295 | NOx sender |
| G61 | Knock sensor 1 | G336 | Intake manifold flap potentiometer |
| G62 | Coolant temperature sender | | |
| G70 | Air-mass flow meter | J17 | Fuel pump relay |
| G71 | Intake manifold pressure sender | J220 | Motronic control unit |
| G79 | Accelerator position sender | | |

less authorised by Volkswagen AG. Volkswagen AG does not guarantee or accept any liability with respect to the correctness of information in this doc.

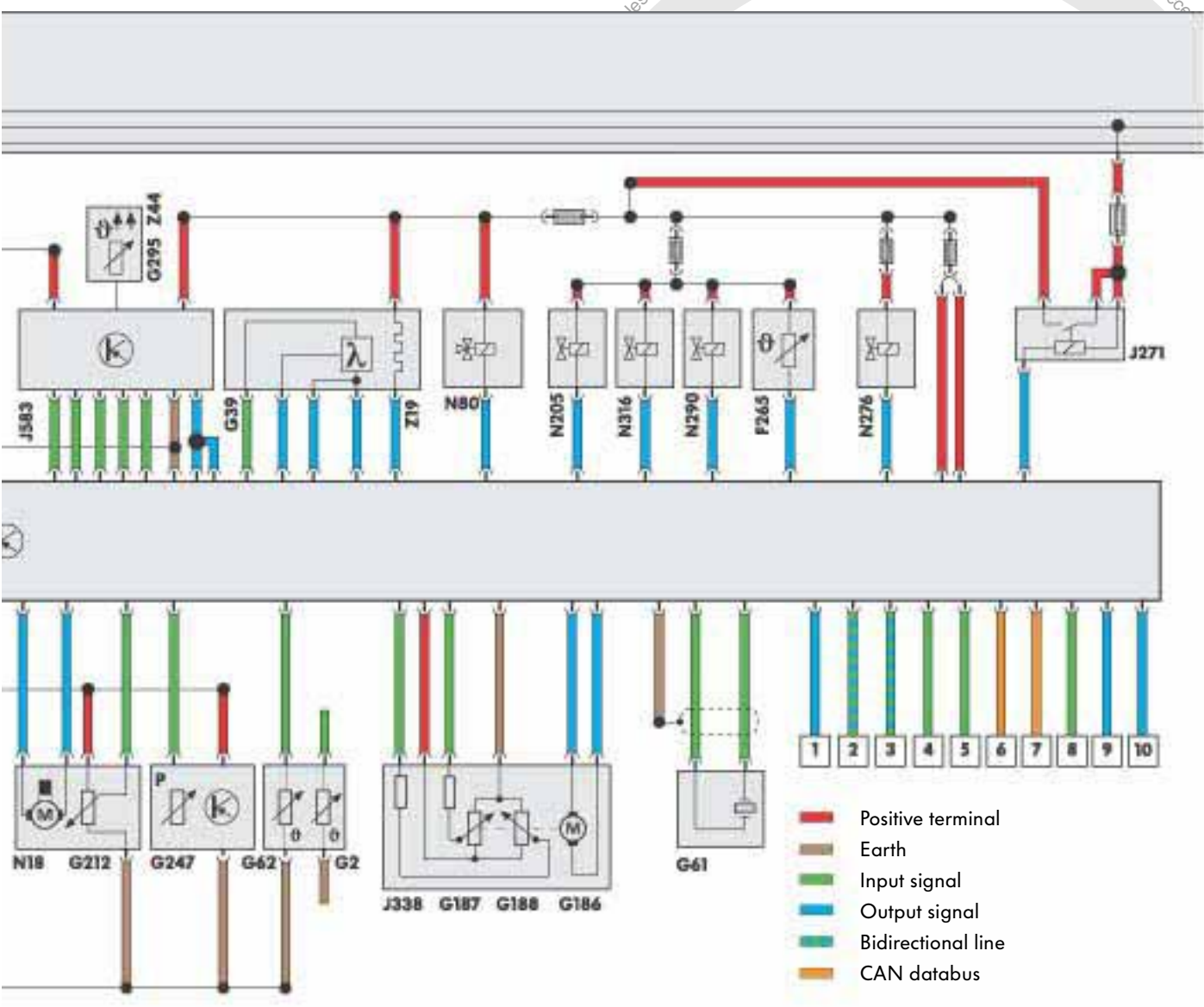

- | | | | | |
|------------------------------|---|------------|--|---------|
| J271 | Motronic current supply relay | Z19 | Lambda probe heater | 252_105 |
| J338 | Throttle valve control unit | Z44 | NOx sender heater | |
| J583 | NOx sensor control unit | | | |
| N70, N127, N291, N292 | Ignition coils 1 - 4 with output stages | 1 | TD signal | |
| N18 | Exhaust gas recirculation valve | 2 | K/W line | |
| N30-33 | Injectors 1 - 4 | 3 | Air conditioner compressor | |
| N80 | Activated charcoal filter system solenoid valve 1 | 4 | A/C ready | |
| N205 | Inlet camshaft timing adjustment valve -1- | 5 | PWM signal from high pressure sender G65 | |
| N276 | Fuel pressure regulating valve | 6 | CAN-Bus High | |
| N290 | Fuel metering valve | 7 | CAN-Bus Low | |
| N316 | Intake manifold flap air flow control valve | 8 | 3-phase AC alternator terminal DFM | |
| P | Spark plug socket | 9 | Fan control 1 | |
| Q | Spark plug | 10 | Fan control 2 | |
| | | 11 | Line to terminal 50 | |
| | | 12 | Line to door contact switch | |
| | | 13 | Line to airbag | |



Test your knowledge

1. The camshaft timing control results in ...

- a) ... an improvement in engine smoothness.
- b) ... optimum adjustment of internal exhaust gas recirculation with regard to emissions and fuel consumption
- c) ... an improvement of the torque curve.

2. Why are the cylinder liners plasma-coated?

- a) The plasma coating saves weight.
- b) The plasma coating reduces the friction between the piston ring and the cylinder liner.
- c) The plasma coating is more easily workable than the cylinder liner.

3. The specially shaped piston recess have the following purpose:

- a) ... to save weight through material reduction.
- b) ... to reduce combustion temperature through controlled mixture control.
- c) ... to channel the fuel and the fresh air to the spark plug.

4. Which of the following statements regarding the stratified charge mode are true?

- a) the fuel is channelled to the spark plug through the fuel recess of the piston and by the tumbling airflow.
- b) the fuel is injected directly into the cylinder during the final third of the compression stroke.
- c) At the point of ignition, an inner layer comprising an ignitable mixture and an outer layer comprising air and recirculated exhaust gases has formed inside the combustion chamber.

5. Which of the following statements regarding homogeneous mode are true?

- a) In homogeneous mode, the fuel mixes uniformly (homogeneously) with the intake air throughout the combustion chamber.
- b) Homogeneous mode is equivalent to the operating mode of an engine with an intake manifold injection system.
- c) In homogeneous mode, the fuel is injected directly into the cylinder during the intake stroke.

6. What is the task of the intake manifold flap changeover mechanism?

- a) The intake air tumbles into the cylinder through the actuated intake manifold flap..
- b) Internal exhaust gas recirculation is controlled by the intake manifold flap.
- c) When the intake manifold flap is actuated, the intake air flow rate increases.

7. What pressures prevail in the fuel system?

- a) In the high-pressure fuel system, the pressure is increased to max. 2000 bar.
- b) In the low pressure fuel system, the pressure during normal operation is 3 bar.
- c) In the high-pressure fuel system, the pressure is between 50 and 100 bar.

8. What is regeneration mode?

- a) In regeneration mode, the NOx storage catalytic converter is purged of nitrogen oxides or sulphur.
- b) In regeneration mode, the engine management system changes over to stratified charge mode.
- c) Regeneration mode is a fuel-saving lean operating mode.



Special tools

Special tools

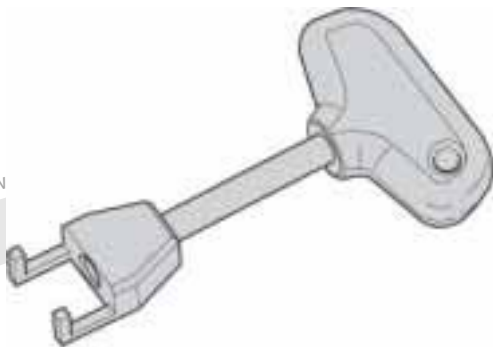
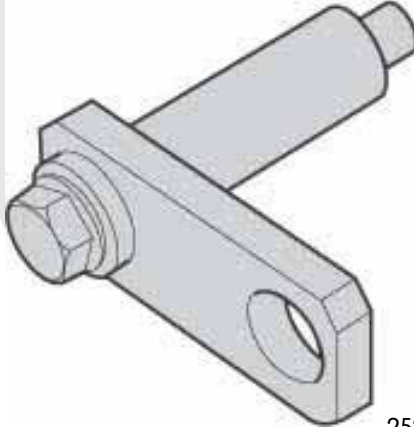
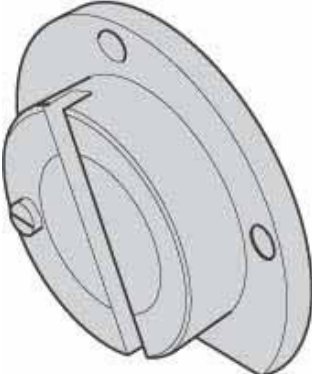
Designation	Tool	Use
<p>T 10094 Pulling-off tool</p>	 <p>252_149</p>	<p>The pulling-off tool is used to pull out the single-spark ignition coil.</p>
<p>T 10109 Holder</p>	 <p>252_133</p>	<p>The holder is attached to the cylinder block to support the engine.</p>
<p>T 10110 Fixing flange</p>	 <p>252_134</p>	<p>The fixing flange is used to adjust and check the correct camshaft position when fitting the camshaft adjuster.</p>



Solutions to questions on pages 52-53

1.) b,c

2.) a,b

3.) c

4.) a,b,c

5.) a,b,c

6.) a,c

7.) b,c

8.) a





For internal use only © VOLKSWAGEN AG, Wolfsburg
All rights reserved. Technical specifications subject to change without notice.
140.2810.71.20 Technical status: 4/01

 This paper is produced from
non-chlorine-bleached pulp.