

Service.



Self-Study Programme 225

The electro-mechanical power steering system

Design and Function

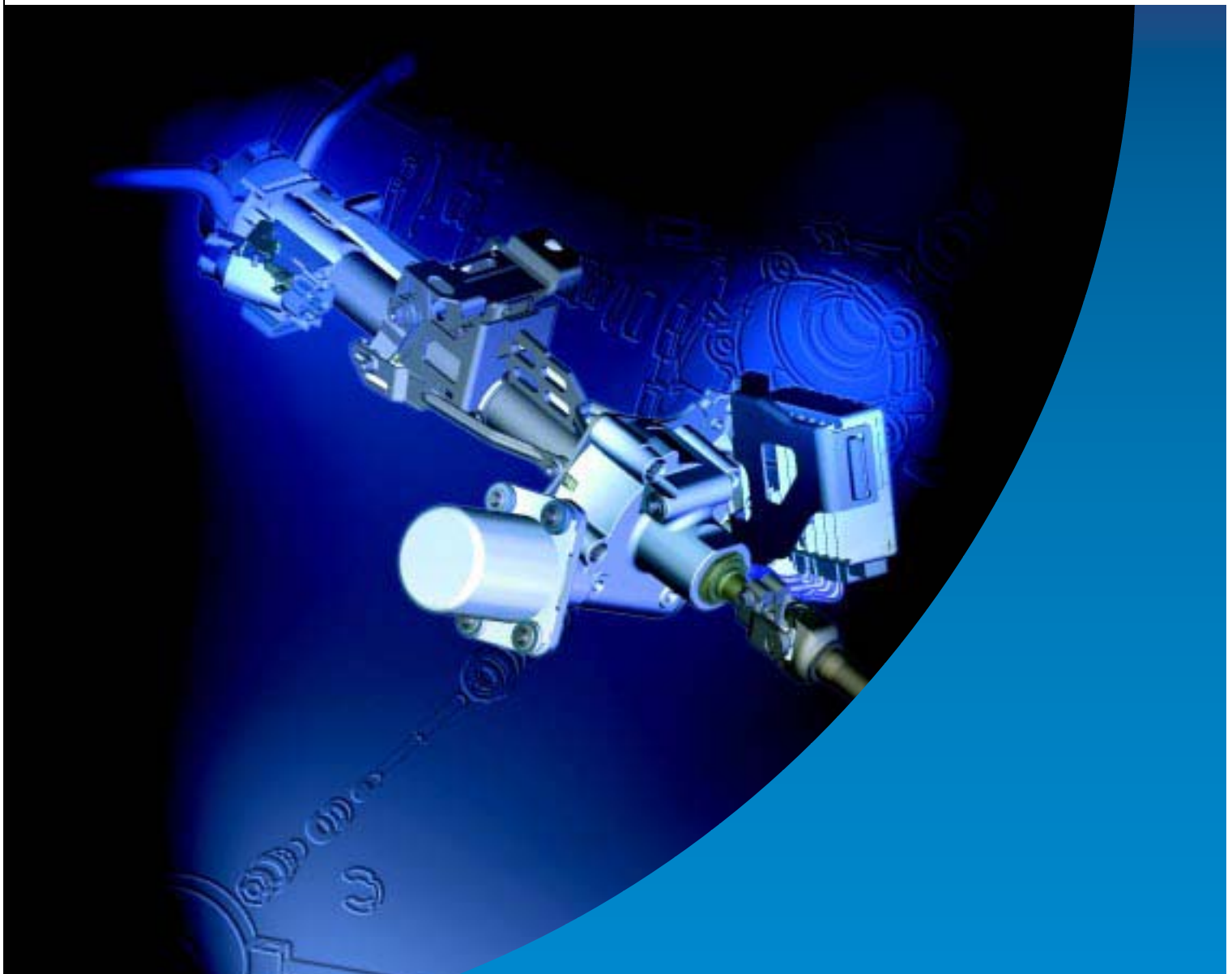

The electro-mechanical power steering system assists the steering movement performed by the driver by means of an electric motor. This motor, in turn, drives a worm gear. The speed-dependent steering system conveys a direct steering feel, without any annoying feedback from the road to the driver.

This Self-Study Programme explains this new technology and the differences compared with conventional hydraulic power steering systems.

The electro-mechanical power steering system is currently fitted to the Lupo 3L TDI.

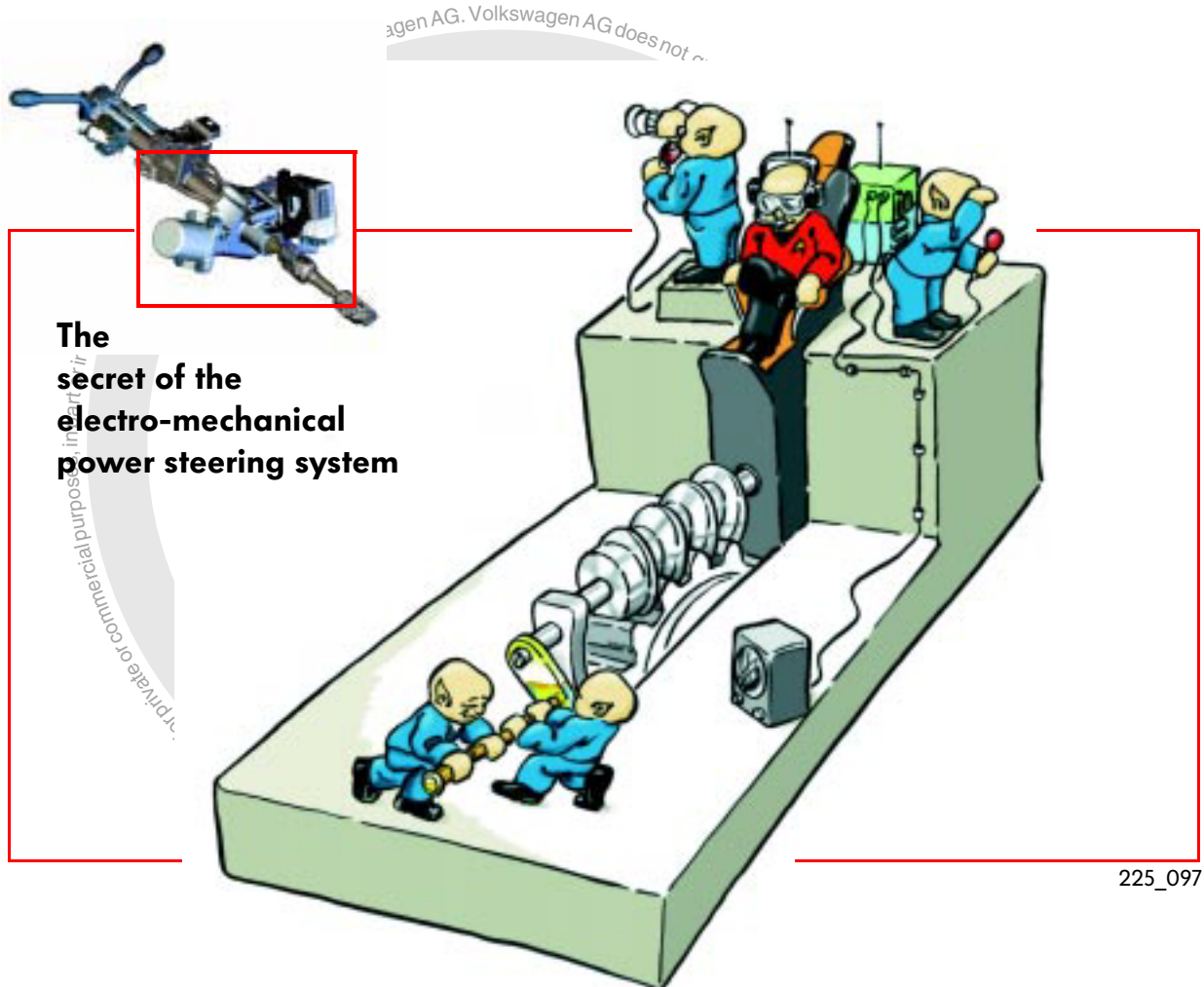

New

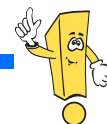

Important Note



The Self-Study Programme explains the design and function of new developments!
The contents of this SSP are not updated.

Please always refer to the relevant Service Literature for all inspection, adjustment and repair instructions.

Table of contents



Introduction	4
The steering mechanism	8
System overview	12
The electronics of the steering system	13
Functional description	18
Function diagram	21
Service	22
Test your knowledge	23

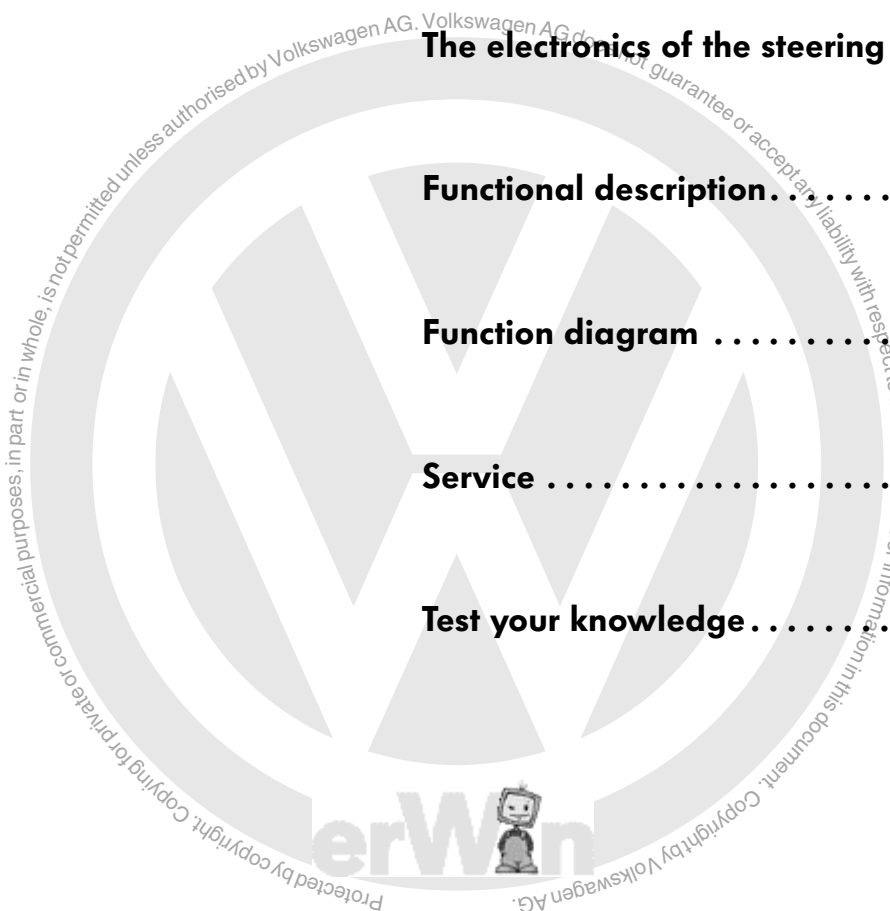

Introduction



The component parts of the steering column

The main components of the new power steering system are:

- the steering column switch,
- the steering column tube,
- the worm gear,
- the steering position sender, and steering moment sender
- the electro-mechanical power steering motor,
- the steering column electronics control unit, and
- the universal joint shaft to the mechanical steering gear.

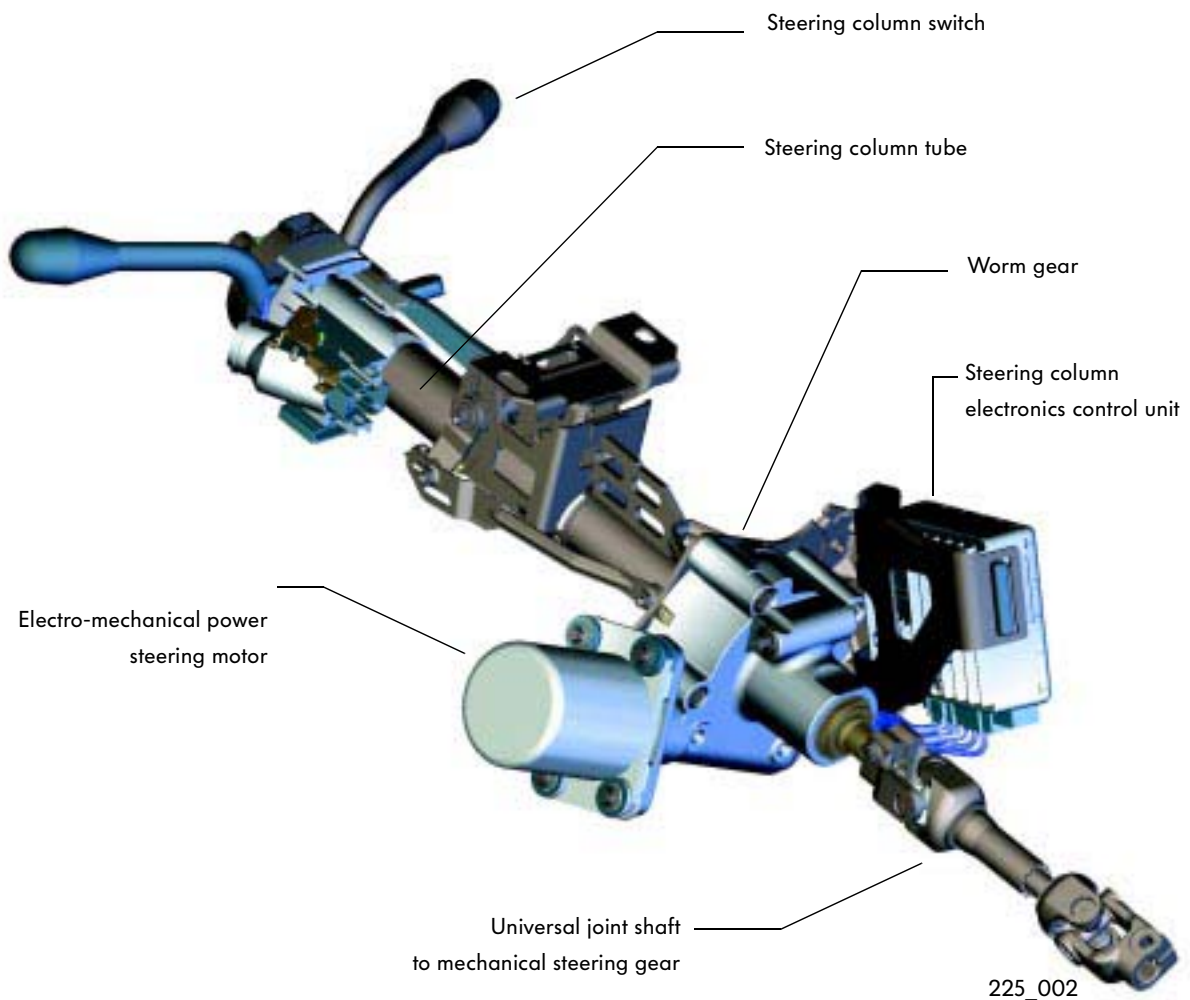

is not permitted unless authorised by Volkswagen AG. Volkswagen AG does not guarantee or accept any liability with respect to the correctness of information in this

Protected by copyright. Copyright by Volkswagen AG. Volkswagen AG does not guarantee or accept any liability with respect to the correctness of information in this document.



What you need to know about the function of the electro-mechanical power steering system:



225_060

1. The system offers the driver power-assisted steering in dependence on actual driving conditions

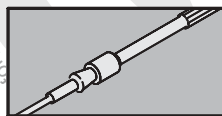

225_061

2. The steering movement of the driver is transmitted to the worm gear and steering gear via the steering shaft and an intermediate spindle.



225_062

3. Self-alignment of the steering wheel in the straight-ahead position is assisted by the electro-mechanical power steering system.

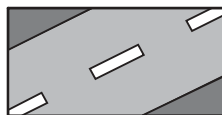

225_063

4. The system conveys the feeling of contact with the road to the driver.

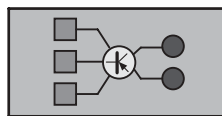

225_066

5. The system monitors the input and output signals, as well as operation of the component parts of the steering system.

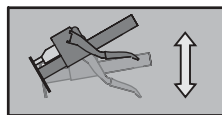

225_065

6. The safety steering column is adjustable for height, and incorporates the proven crash concept pioneered in the Lupo.



225_064

7. It provides anti-theft protection through a lock on the steering shaft.

Introduction



Overview

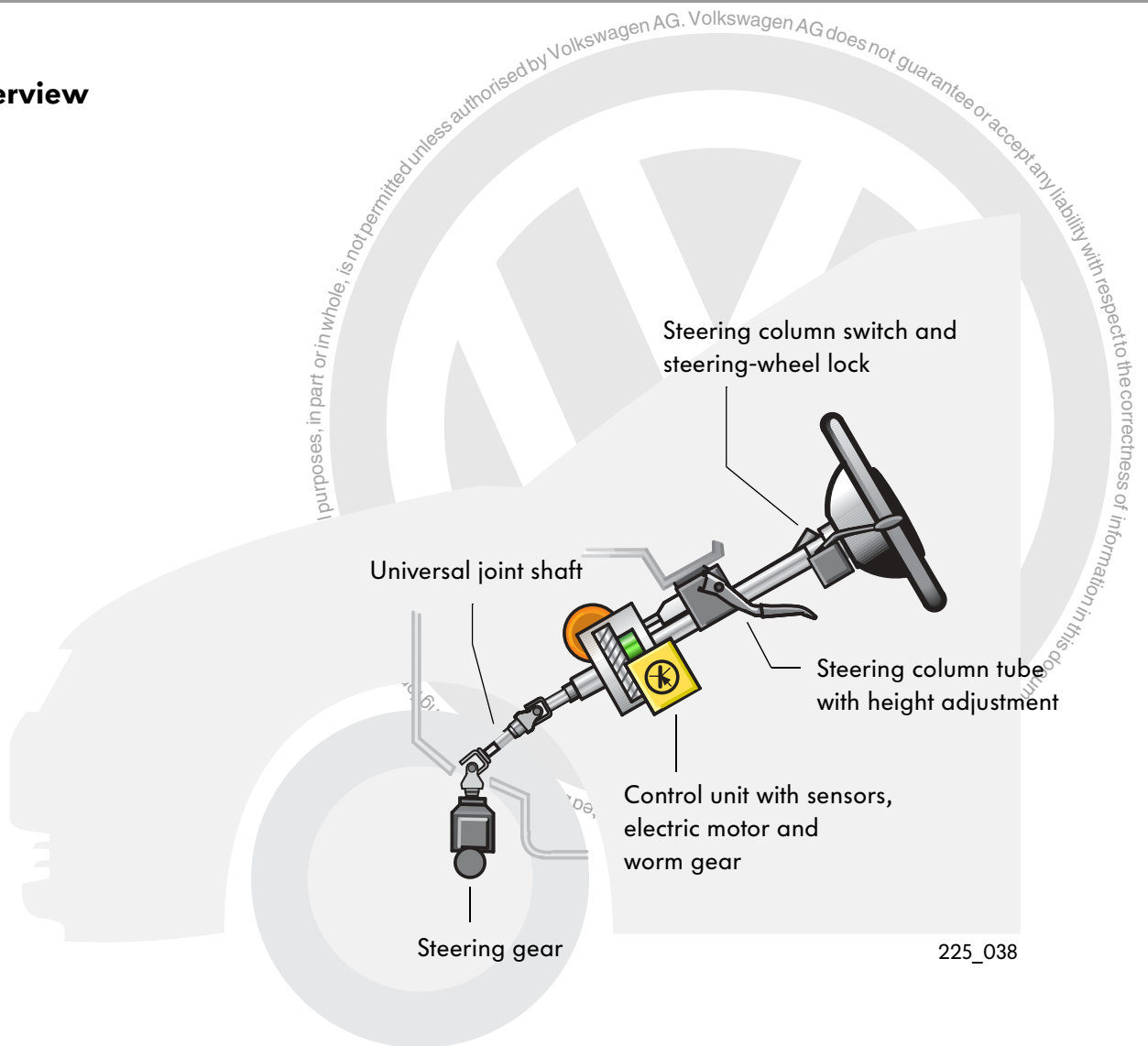

The entire electro-mechanical power steering system is integrated in a compact unit. This unit comprises all component parts of the steering gear, e.g. control unit, electric motor and the sensors required for control. Hence, there is no longer any need for complex wiring arrangements.

A electro-mechanical power steering system and a hydraulic system have totally different modes of operation.



**By comparison:
The specifications emphasise the difference.**

	Hydraulics	Electro-mechanical system
Weight	16.3 kg	11.3 kg
Power consumption Urban cycle	400 W	25 W
Motorway cycle	800 - 1000 W	10 W
Additional consumption compared to mechanical steering gear in litres per 100 km	0.1l *	0.01 **

* referred to 44 KW SDI engine

** referred to Lupo 3L with 1.2l TDI engine

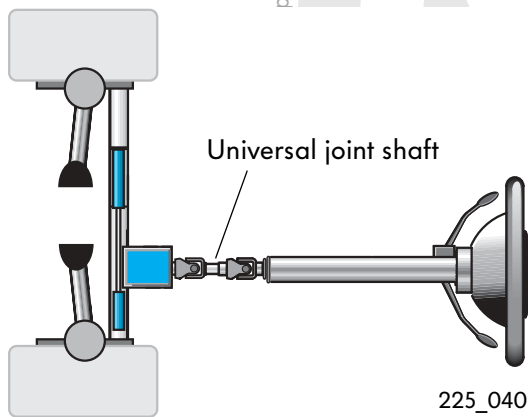

The hydraulic power steering system

In the hydraulic power steering system, the system components after the universal joint shaft are engaged in the steering operation, whereby steering is assisted by oil pressure.

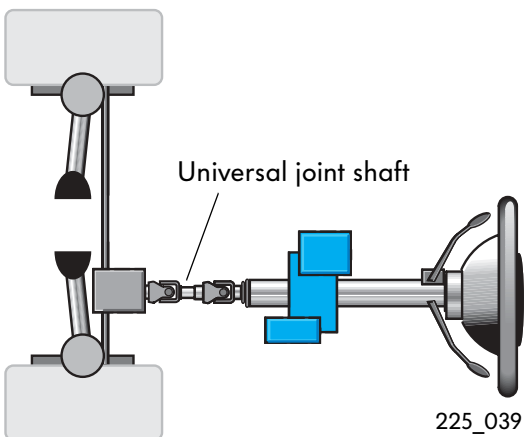

The electro-mechanical power steering system

In the electro-mechanical power steering system, steering is assisted in front of the universal joint shaft. In this system, the assisting moment is generated by an electric motor.

The steering mechanism

The steering column and its component parts

The key component parts of the electro/mechanical power steering system are:

- Steering shaft
- Steering column tube with height adjustment
- Intermediate spindle
- Torsion bar
- Sensor housing with steering moment sender and steering position sender
- Electric motor and coupling
- Worm drive with worm and gear
- Gearbox housing
- Steering column electronics control unit and universal joint shaft

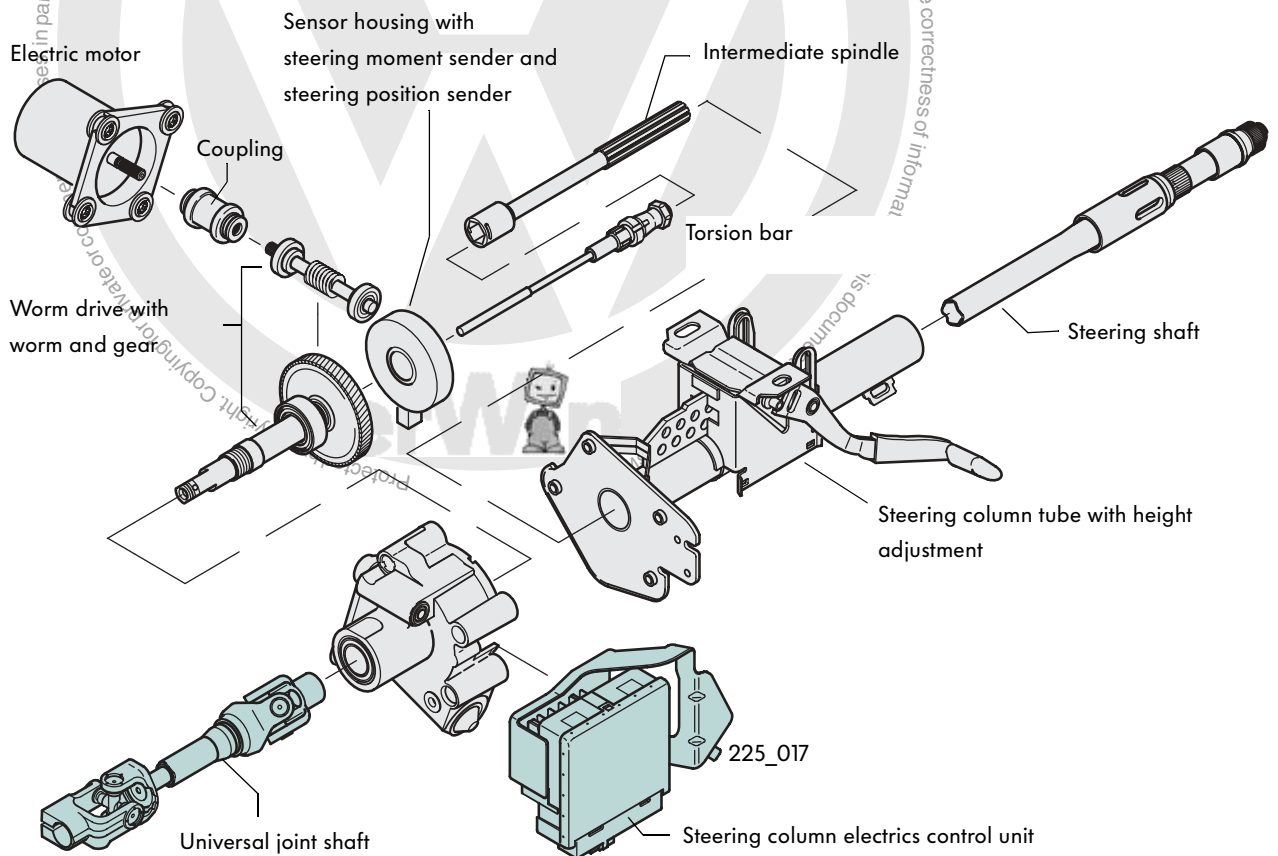

The torsion bar

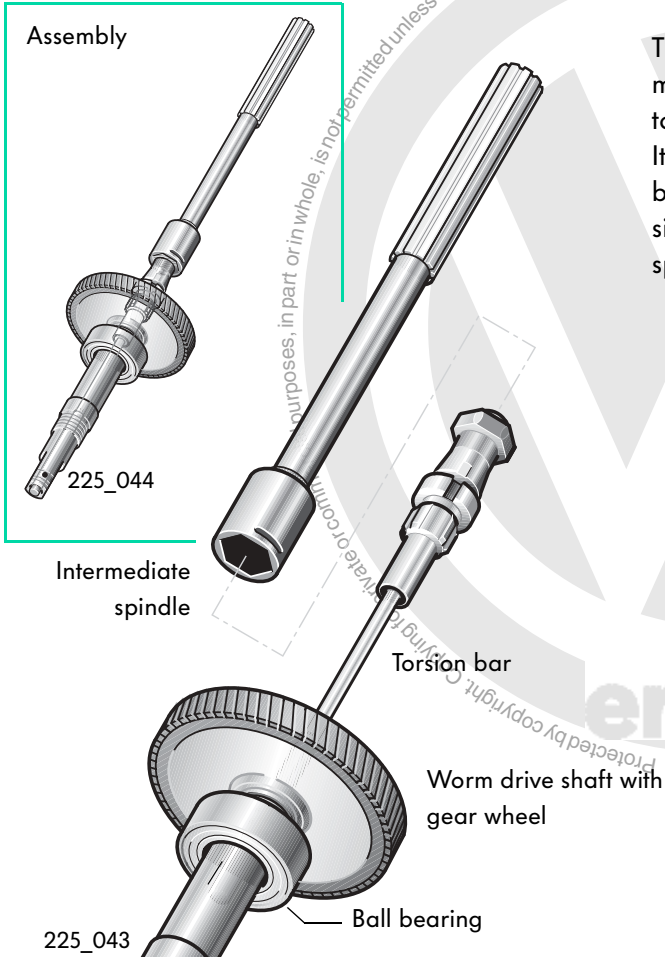

The central component part of the electro/mechanical power steering system is the torsion bar. It is made from tempered steel, which allows the bar to rotate about its longitudinal axis. The torsion bar mechanically connects the intermediate spindle to the worm drive shaft.

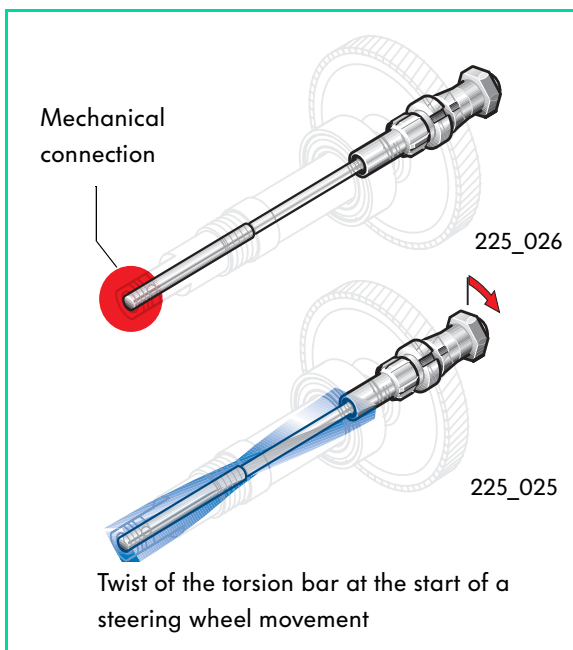

Function

Through this connection, the intermediate spindle and the worm drive shaft are able to counter-rotate about a narrow angle. This narrow angle is enough for the system to detect the start of a steering operation.

Steering mechanism

The worm gear

is located in an aluminium gearcase where the electric motor is also mounted.



A worm on the motor shaft meshes with the gear on the steering shaft. The gear ratio is 22:1. The gear body and the worm are made of metal. The gear ring is manufactured from plastic to reduce mechanical noise.

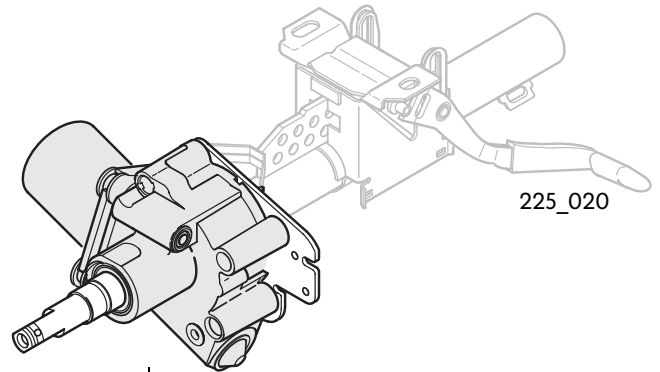

225_020

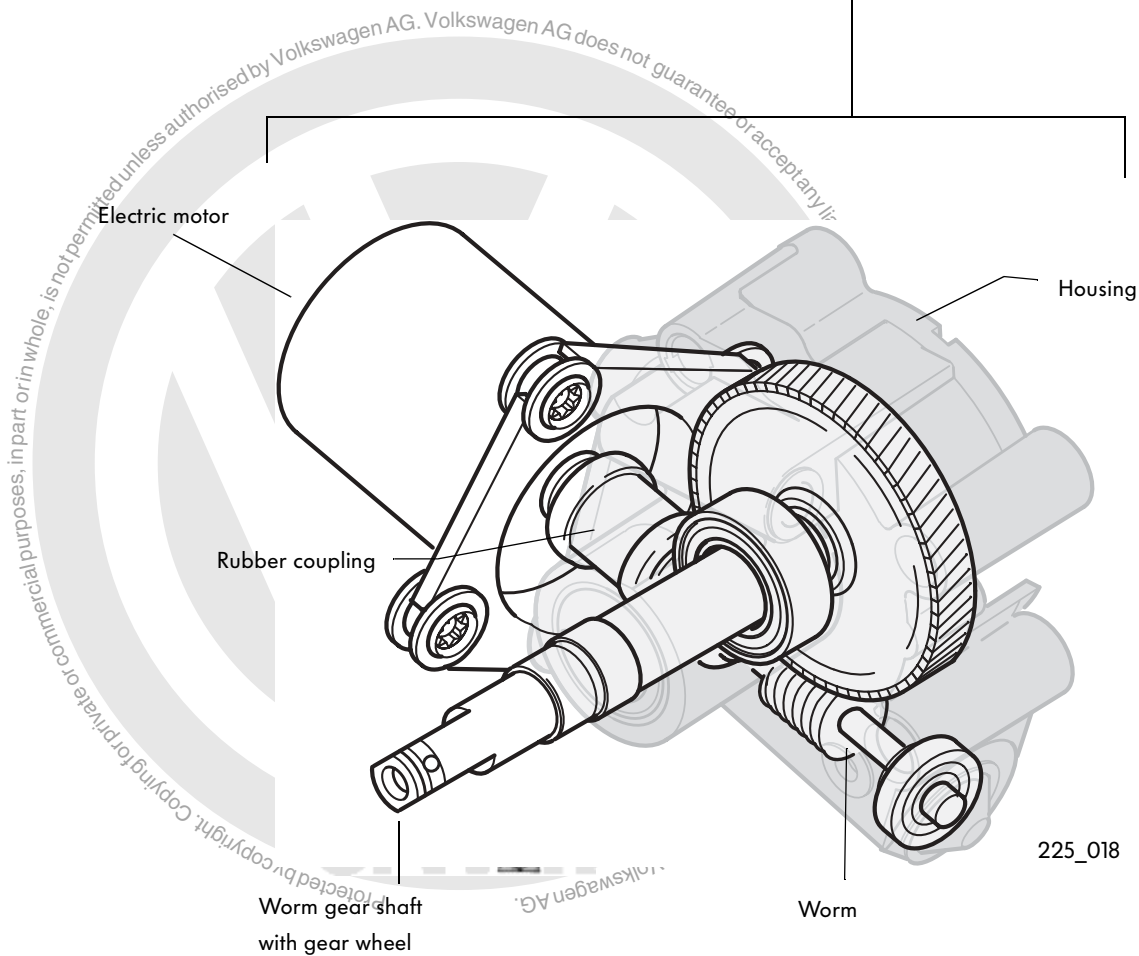

225_018

The height adjustment

The height adjustment mechanism is securely connected to the steering column tube. Adjustment travel is 39 mm.

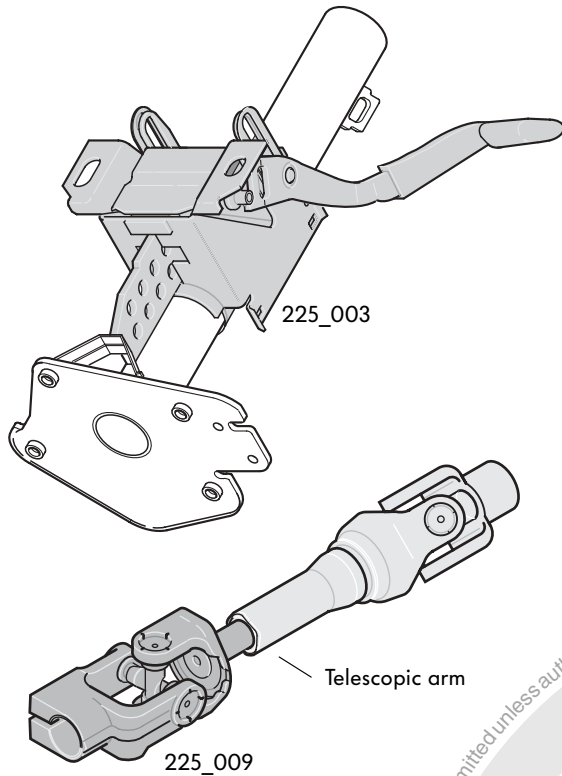

The universal joint shaft

The two forks of the drive shaft are connected to a short telescopic arm. This telescopic arm allows length compensation of the height adjustment mechanism and affords the occupants protection in a head-on collision.

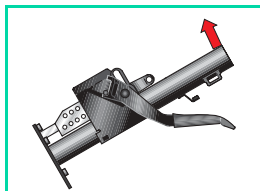

225_023

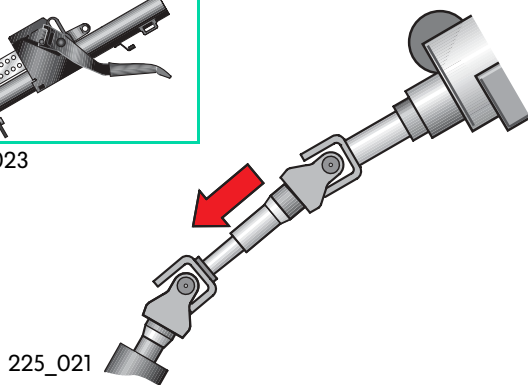

225_021

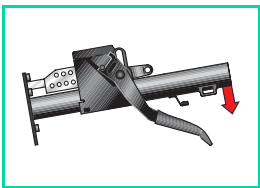

225_024

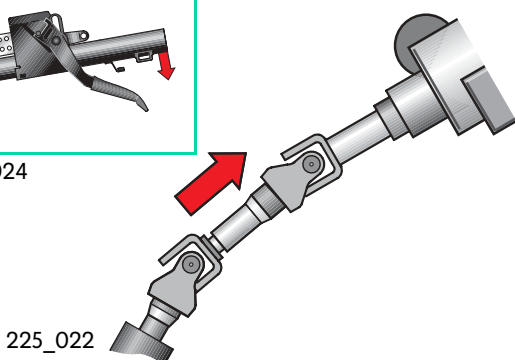

225_022

If the steering wheel is adjusted upwards, the telescopic arm is compressed (i.e. made shorter). This reduces the distance between steering wheel and steering gear.

If the steering wheel is adjusted downwards, the distance between steering wheel and steering gear is increased, and the telescopic arm is extended.

System overview

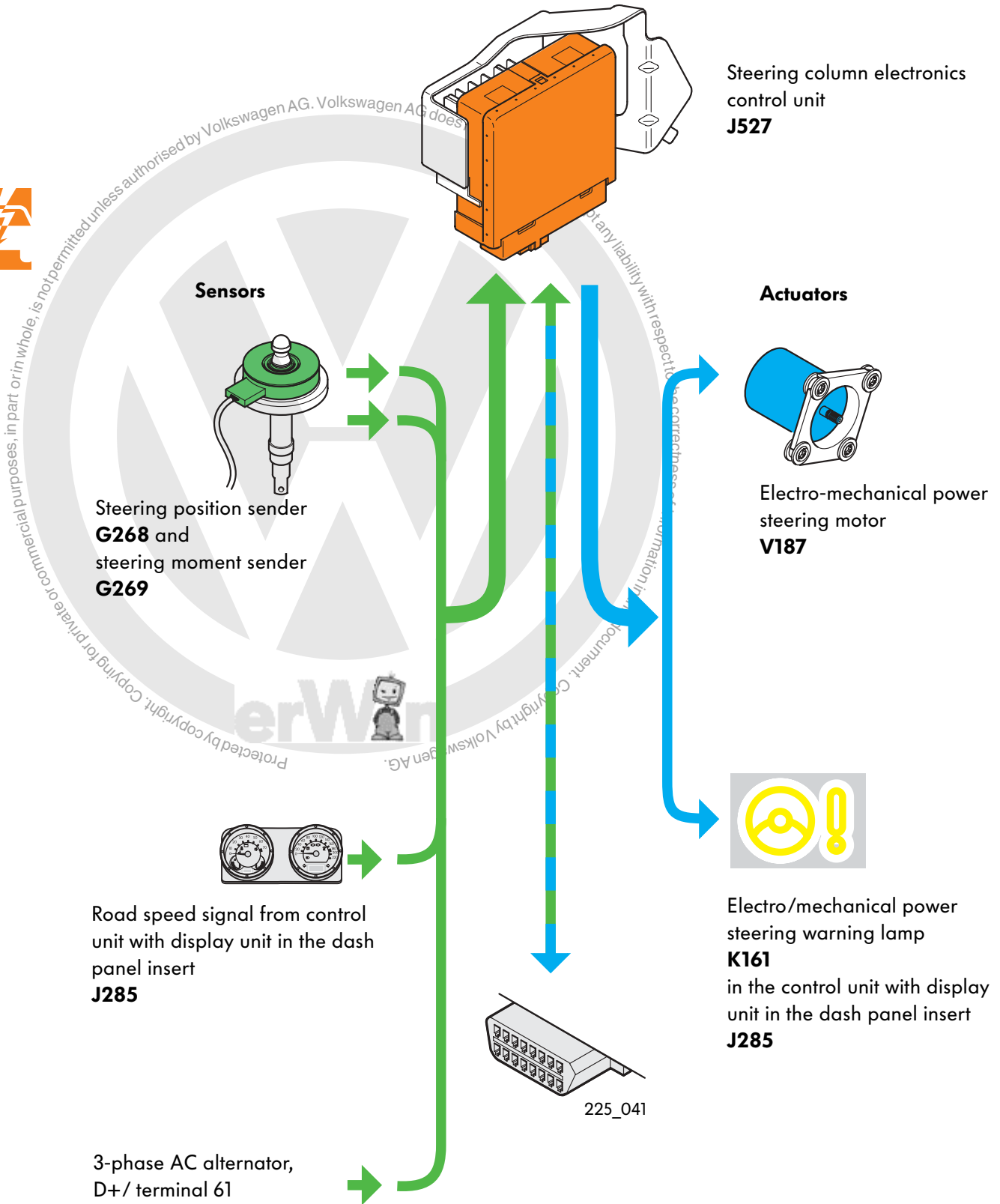

The electronics of the steering system

The sensor housing

Steering position sender G268 and steering moment sender G269 are located in a housing. The sensor housing is mounted on the worm gear shaft above the gear. The sensor housing is connected to the control unit via a 6-pin connector.

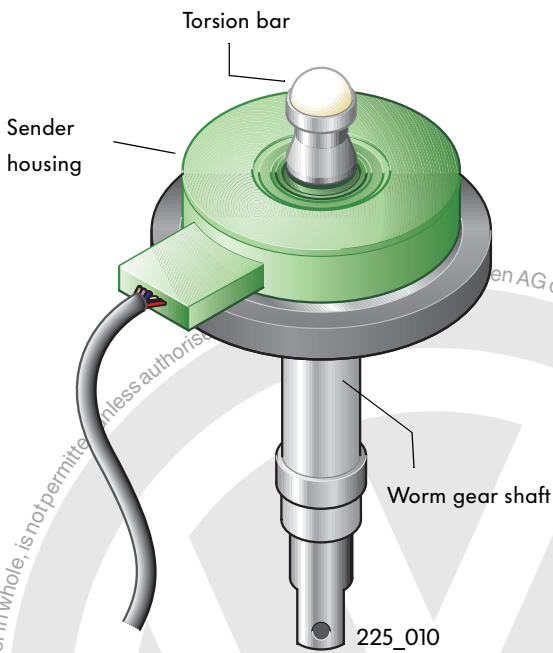

Steering position sender G268

is connected to the worm gear shaft. It registers the steering wheel lock and/or the current position the steering

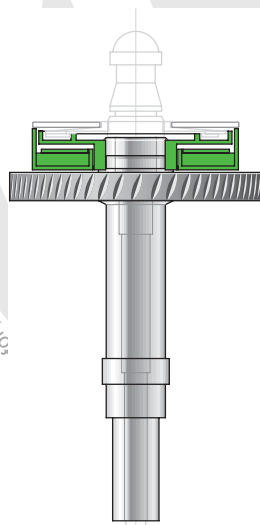

Steering moment sender G269

is connected to the torsion bar. It registers a rotation angle of the torsion bar in relation to the intermediate spindle. The control unit calculates a torque from this signal. If the calculated torque exceeds a value of 0.01 Nm, the control unit assumes that a steering assistance is required.

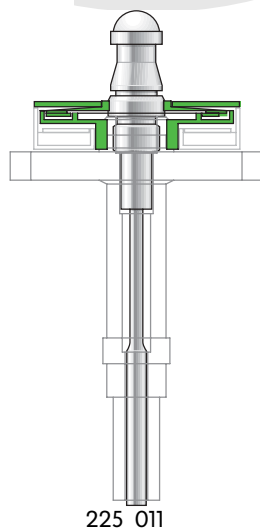

for private or commercial purposes, in part or in whole, is not permitted without the express written authorization of Volkswagen AG. Copyright by Volkswagen AG. This document contains confidential information with respect to the core business of Volkswagen AG.

The electronics of the steering system

Electrical circuit

The two sensors are connected to the control unit by three separate wires.

Effects of failure

If the steering moment sender fails, the system is deactivated. If the steering position sender fails, the »active self-alignment« function is deactivated. In both cases, the fault indicator lamp comes on.



Sensor design

The two sensors are sliding contact potentiometers. The steering position sender registers the steer angle of the steering system through rotation of the inner ring in relation to the housing lower section. The steering moment sender registers the rotation of the torsion bar.

The housing has an inner ring. This ring is mounted on the worm drive shaft with a clamping ring and can rotate relative to the housing. Two pairs of potentiometers scan the brushes of the inner conductor on the PCB in the housing. This part is the steering position sender. The other conductors transfer the signal from the steering moment sender.

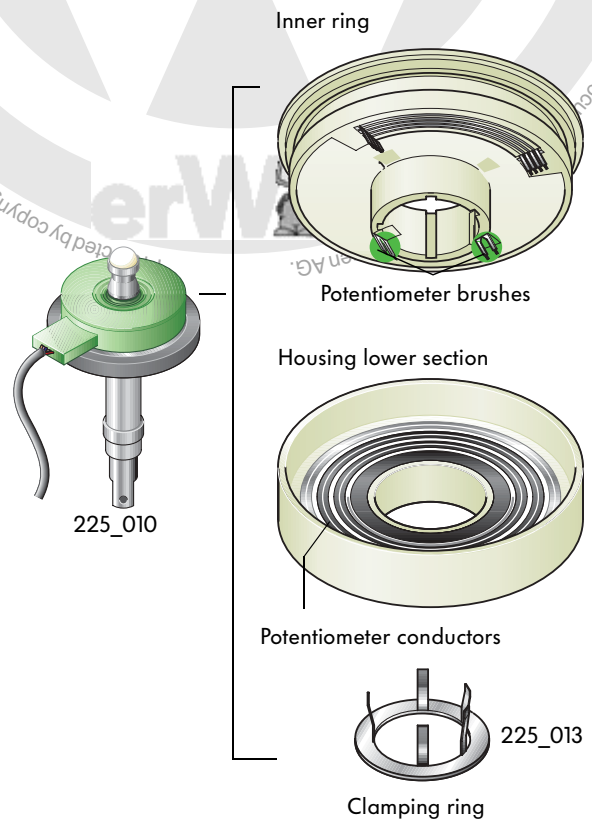
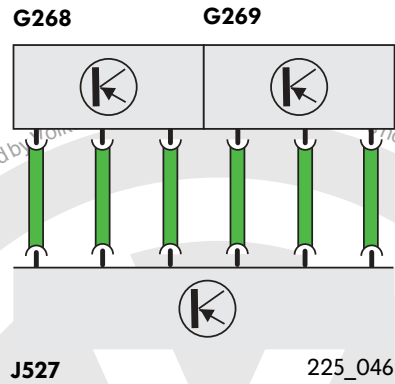

The steering moment sender is mounted in the inner ring. The inner ring is a plastic ring with two pairs of potentiometer brushes. These brushes scan the four conductors in the inner ring. The sender ring is connected to the housing cover. It fits exactly on the head of the torsion bar. When the torsion bar rotates, the cover also rotates relative to the inner ring. This movement is detected by the potentiometer brushes and transferred to the control unit as a signal along the printed conductors in the base of housing.

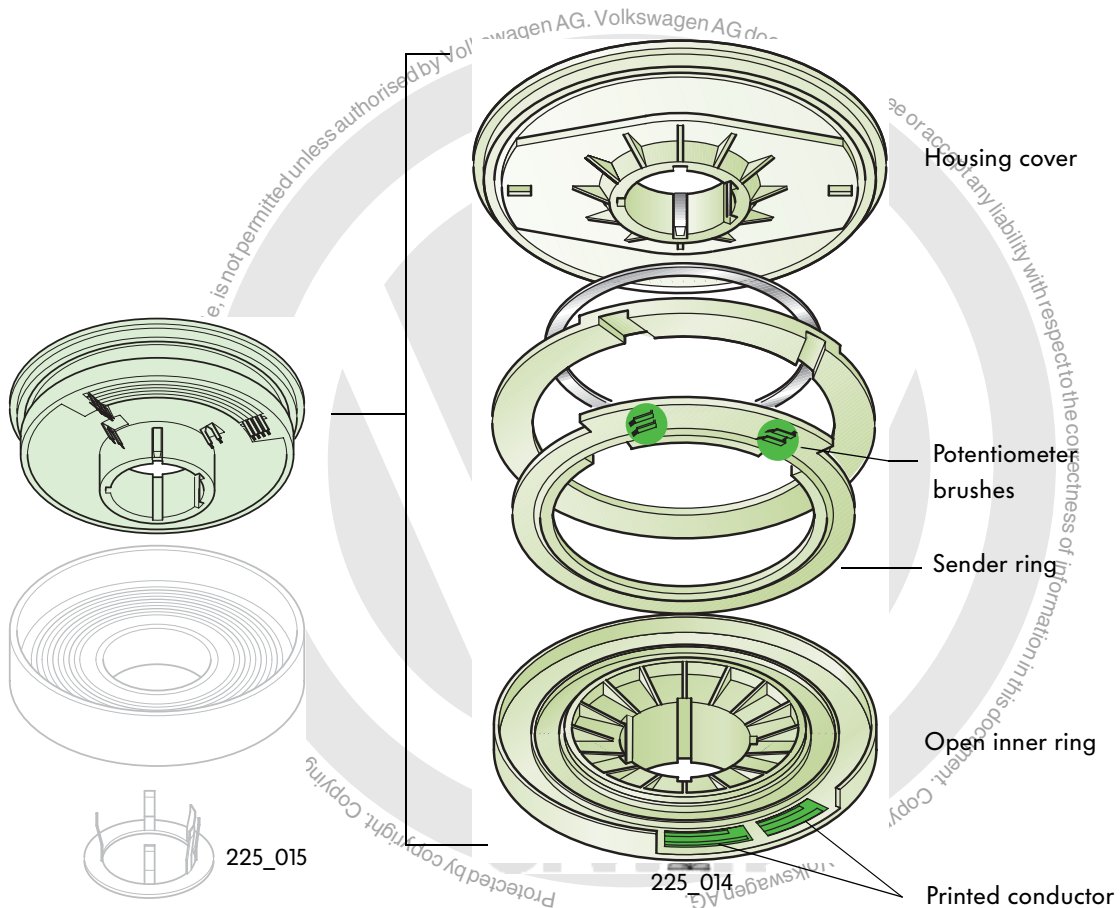

The electronics of the steering system

Steering column electronics control unit J527

This control unit is mounted in a frame which is bolted to the housing of the worm drive.

Five non-interchangeable connectors are attached to the terminal strip of the control unit by clips.



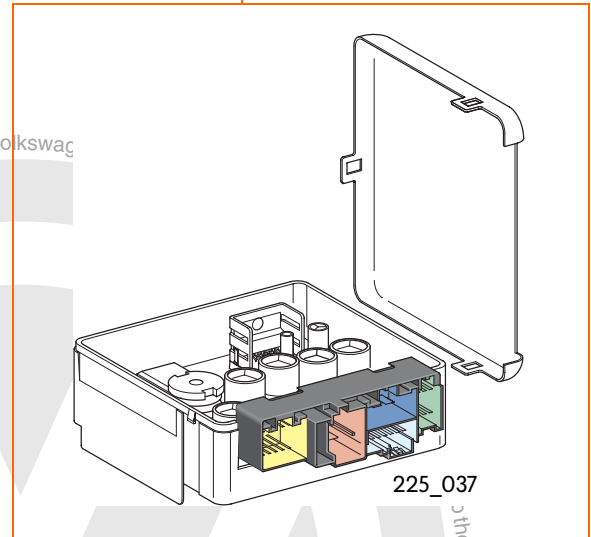
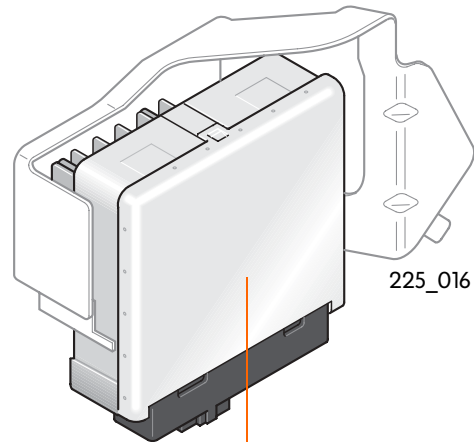

The control unit calculates the steering assistance required from the data from the sensors, making allowance for road speed.

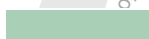

Effects of failure

If the control unit fails, the fault indicator lamp comes on.

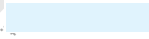
Copyright by Volkswagen AG. Volkswagen
 for private or commercial purposes, in part or in whole, is not permitted unless authorised by Volkswagen AG.

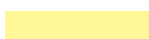
Usage	Drawing colour
Connection to senders G268 and G269	
Motor control leads	
Electric motor phase wires	
Voltage supply, battery terminal 30 and earth terminal 31	
Connection to control unit for display unit in the dash panel insert terminal 15, terminal 61, fault indicator lamp, K-wire, road speed signal	



Electro-mechanical power steering motor V187

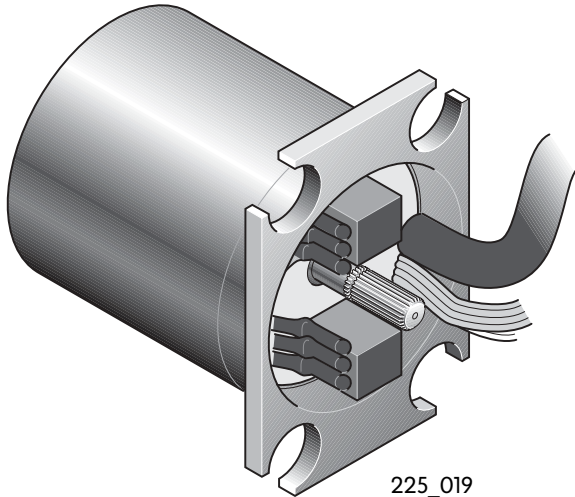

225_019

This motor is bolted to the housing of the worm gear by means of rubber buffers so that no vibrations can be transmitted between the motor and steering column. The motor shaft is connected to the worm shaft via a flexible rubber coupling in such a way that motor starting torque is transmitted softly to the worm gear. The motor itself has a maximum power consumption of 720 W and develops 2 Nm of torque. It has an extremely short response time which allows it to assist steering wheel movements quickly.

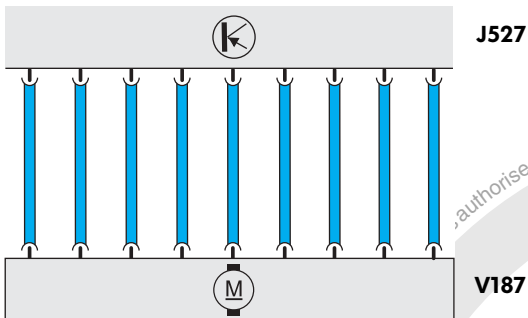

225_048

Electrical circuit

The electric motor receives its voltage supply via steering column electronics control unit J527.

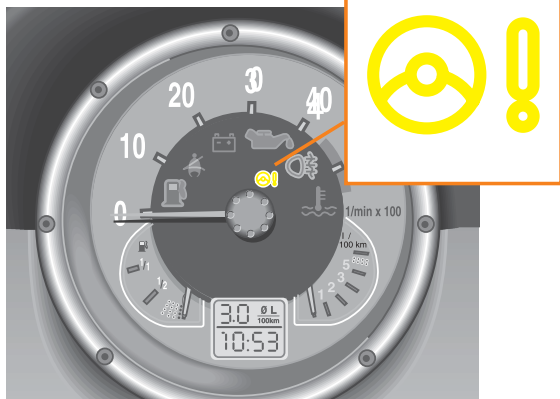

225_027

Electro-mechanical power steering warning lamp K161

This warning lamp is located in the dash panel insert.

If the control unit detects a fault in the power steering system, it activates the warning lamp in the display unit in the dash panel insert.



Functional description

The steering operation

The diagram shows a steering column which is split into an upper section and a lower section. The steering moment sender is integrated in the upper section, while the steering position sender is located in the lower section.

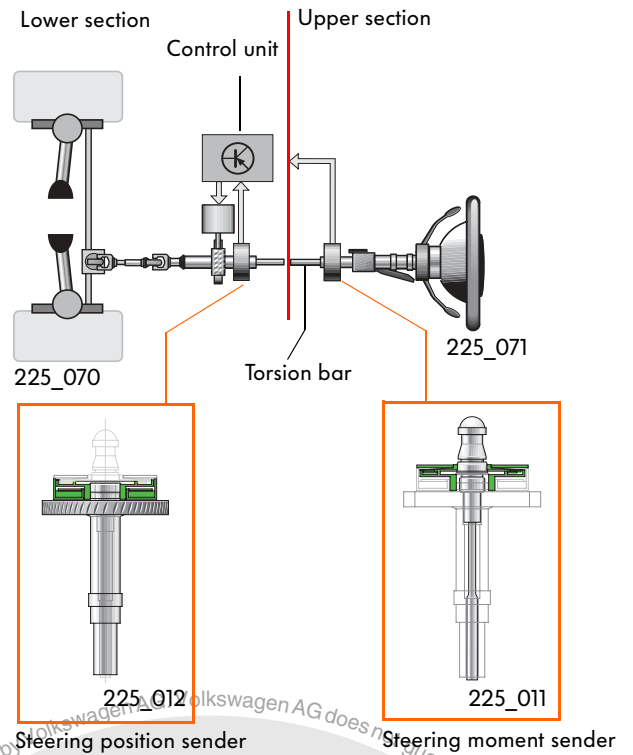

The driver starts to turn the steering wheel. The torsion bar is rotated at the same time. The steering moment sender, which rotates together with the torsion bar, supplies the control unit signals indicating the magnitude and direction of rotation of the torque acting on the steering wheel. The control unit calculates the torque assistance required from the signals and activates the electric motor. The aggregate of torque acting on the steering wheel and torque assistance is the effective torque acting on the steering gear.

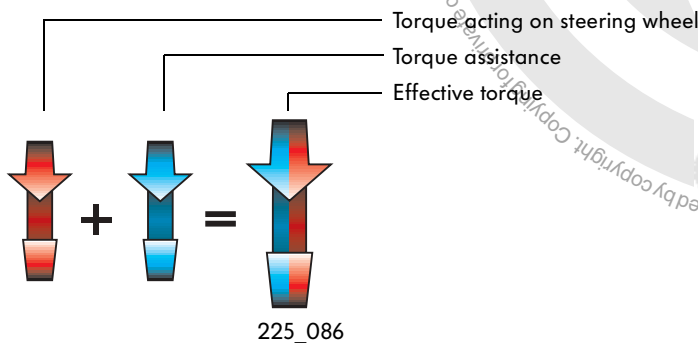
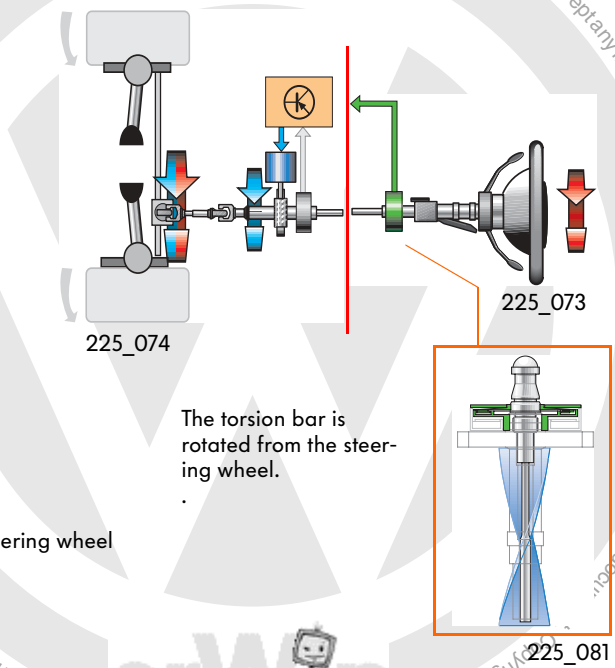

Protected by copyright. Copying for private or commercial purposes is prohibited unless authorised by Volkswagen AG. Volkswagen AG does not guarantee or accept any liability with respect to the correctness of information in this document.

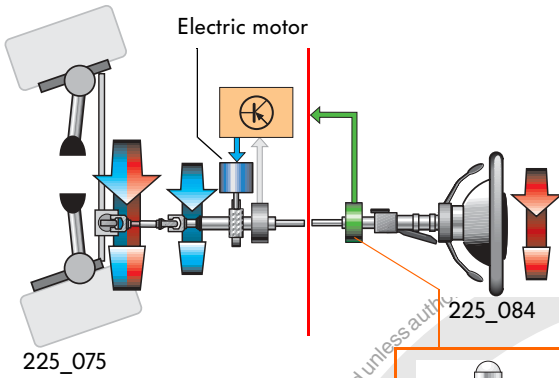

225_075

Electric motor

If the driver increases the torque applied to the steering wheel, the electric motor increases torque assistance. This allows the steering gear to rotate easily.

The torsion bar continues to rotate because the driver continues to apply steering lock

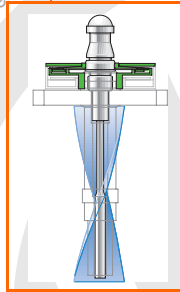

225_081

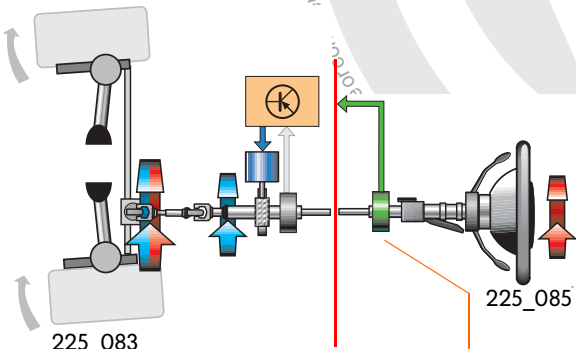

225_083

The torsion of the torsion bar is reduced.

If the driver reduces the torque applied to the steering wheel, the torsion of the torsion bar is reduced. As a result, the steering moment sender supplies a lower signal to the control unit. The control unit reduces the torque assistance by activating the electric motor.

Due to the wheel alignment, the steering system tries to restore the wheels to the straight-ahead position.

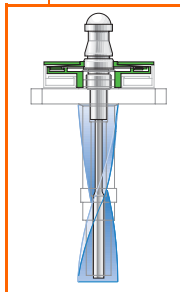

225_091

If resultant restoring moment via the steering gear is greater than the aggregate of the torque acting on the steering wheel and the torque assistance, the system begins to turn the steering back to the straight-ahead position.

Functional description

Active self-alignment

If the driver releases the steering wheel when cornering, the tension on the torsion bar is relieved. At the same time, the electronics deactivate the electric motor. As a result, torque assistance is no longer required.

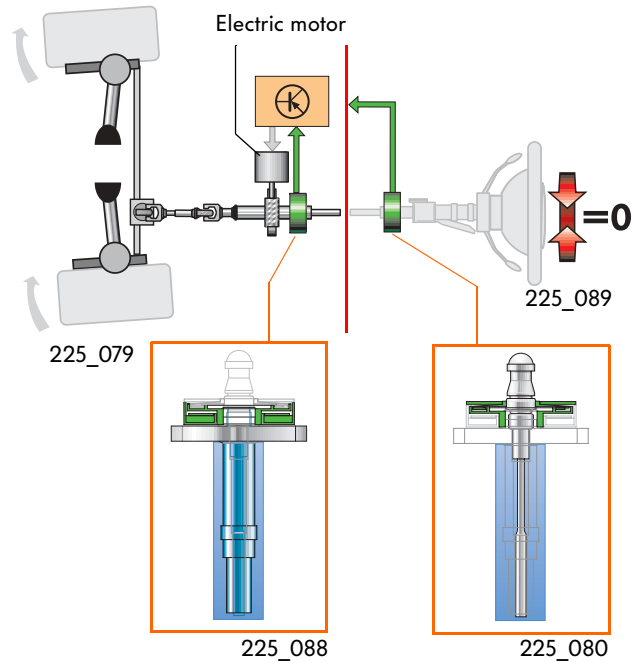

If the vehicle is still not travelling straight ahead, this is registered via the steering position sender. The electric motor is now activated so that the steering is actively turned to the straight-ahead position.

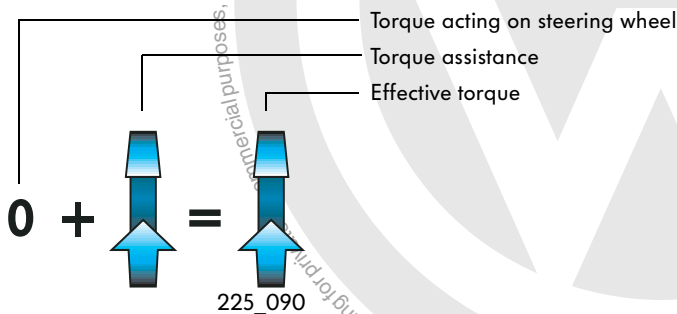
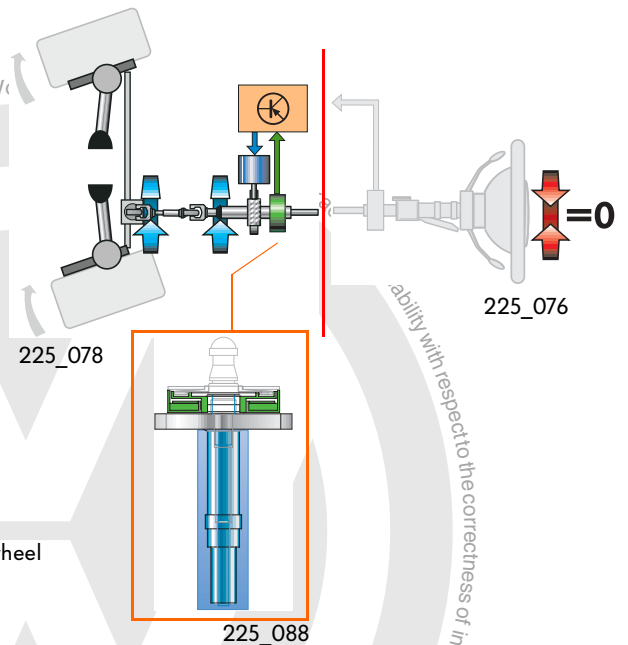

Commercial purposes, in part or in whole, is not permitted unless authorised by Volkswagen AG. V
 Protected by copyright. Copying for private use is permitted. Copying for commercial purposes is not permitted unless authorised by Volkswagen AG.
 ability with respect to the correctness of information in this document. Copyright by Volkswagen AG.



Function diagram

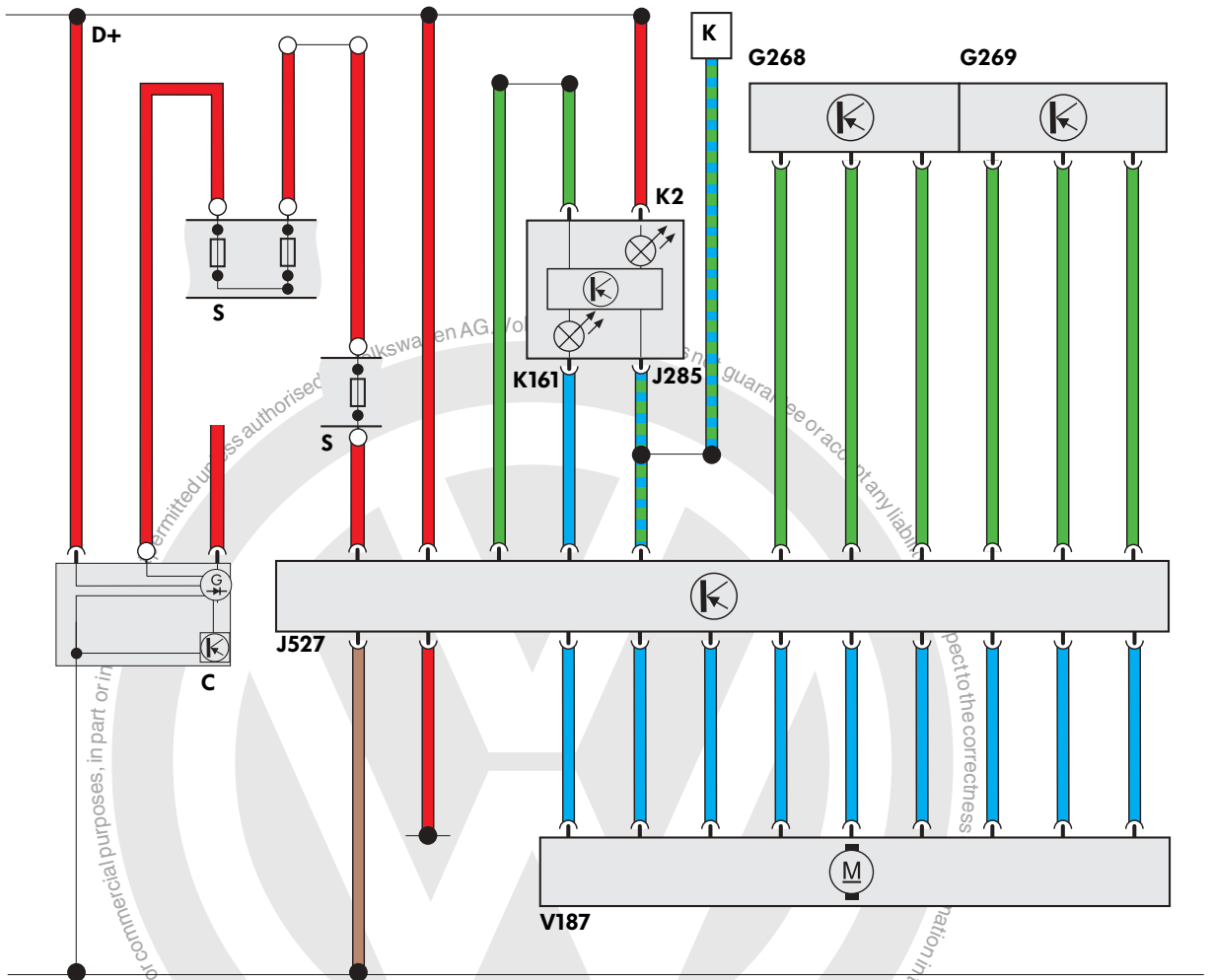

225_042

C 3-phase AC alternator **V187** Electro/mechanical power steering motor

G268 Steering position sender **K** Diagnostic connection

G269 Steering moment sender

J258 Control unit for display unit in dash panel insert

J527 Steering column electronics control unit

K2 Alternator warning lamp

K161 Electro-mechanical power steering warning lamp

S Fuse

- █ Input signal
- █ Output signal
- █ Positive
- █ Earth

Service

Self-diagnosis

The self-diagnosis procedure is initiated with address word 44 "Power steering".

In the self-diagnosis, the electro/mechanical power steering control unit provides the following functions and can be interrogated with Vehicle Diagnostic, Testing and Information System VAS 5051:

Function	Address word
Interrogate control unit version	01
Interrogate fault memory	02
Clear fault memory	05
Read data block	08
Start basic adjustment	04
End of output	06

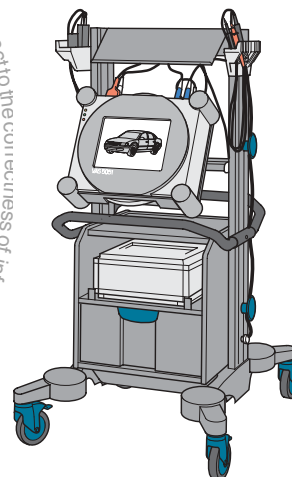

210_102



Servicing the steering system

At present, only the following components of the electro/mechanical power steering system may be replaced individually:

- the steering column switch and
- the lock cylinder

The gearbox with steering column tube, the control unit and the electric motor are always replaced as a whole and may not be disassembled under any circumstances.



Please observe the instructions in the Workshop Manual.

Test your knowledge

1. What sender is required for operation of the electro/mechanical power steering system?

- a. The steering position sender only
- b. The steering moment sender only
- c. The steering position sender and the steering moment sender

2. What is the transmission ratio in the worm gear?

- a. 21:1
- b. 22:1
- c. 23:1

3. Define the following components

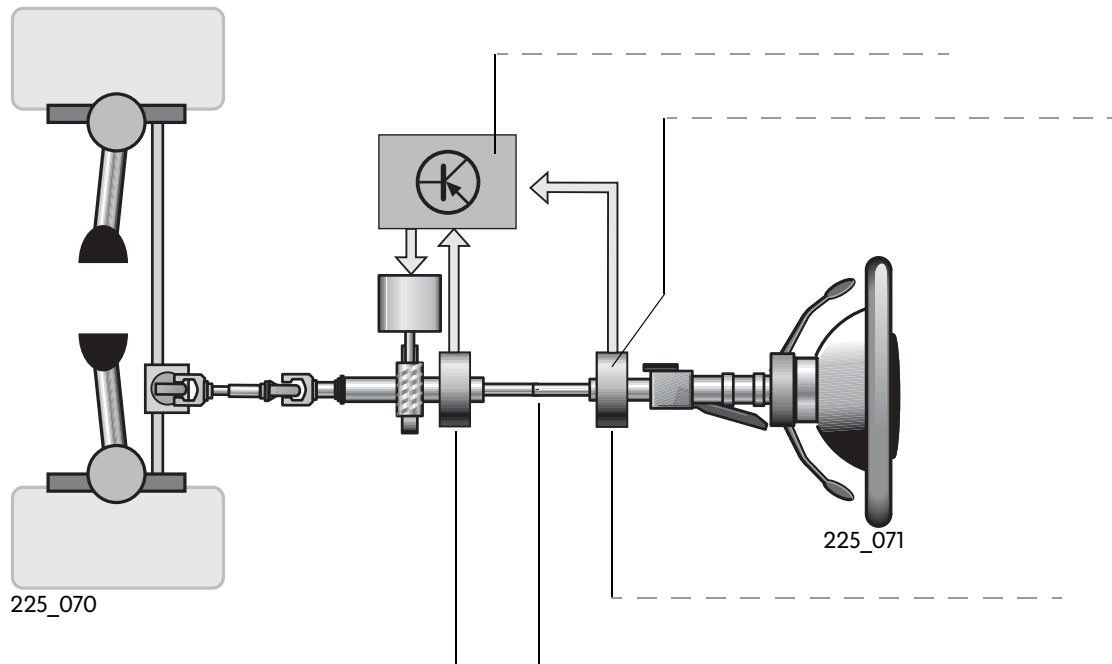

Solutions:
1.c
2.b
3. Components: see page 18

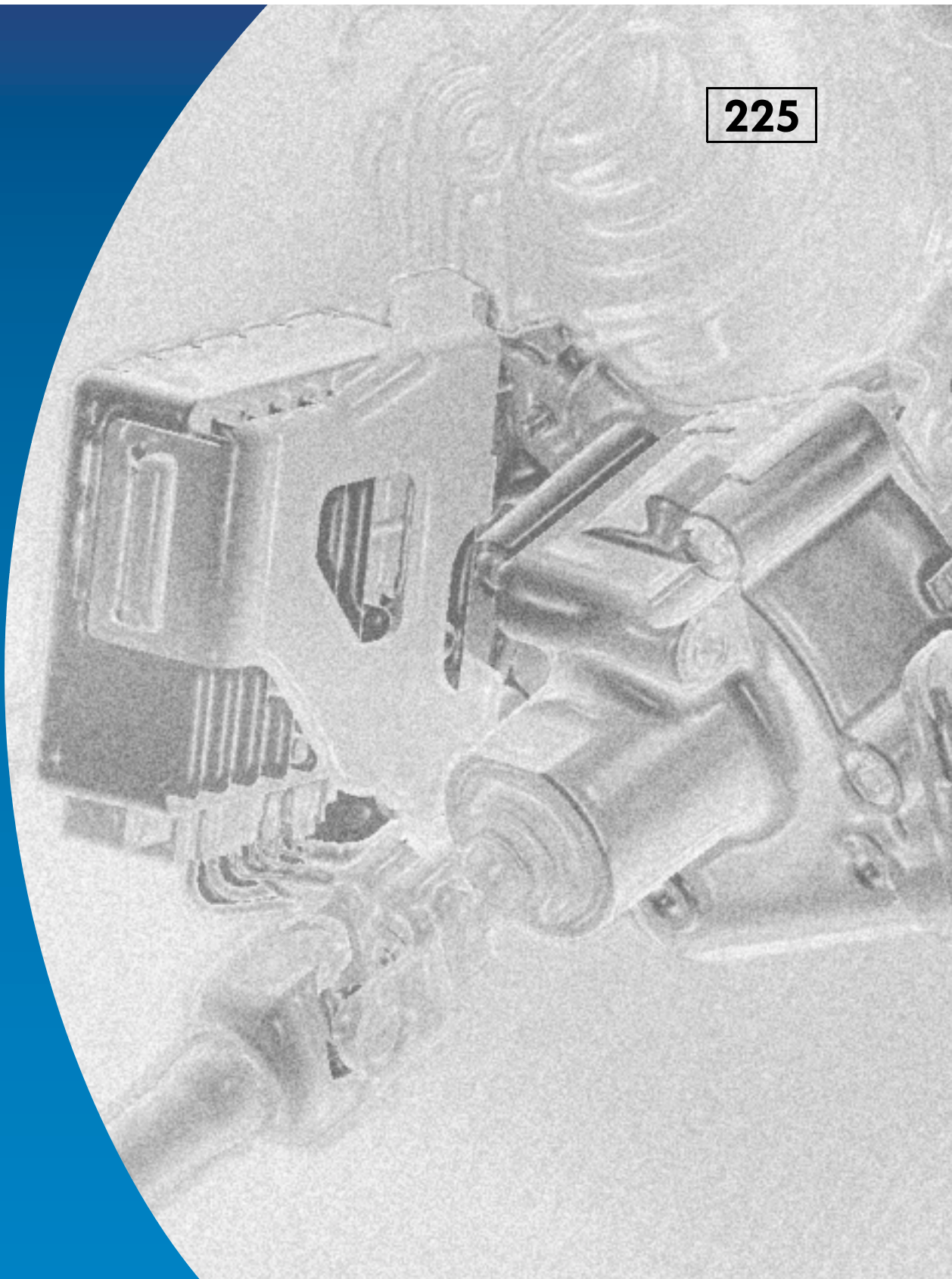

For internal use only © VOLKSWAGEN AG, Wolfsburg

All rights reserved. Technical specifications subject to change without notice.

040.2810.44.20 Technical status: 1/00

♻️ This paper is produced from
non-chlorine-bleached pulp.