

Service.



Self-Study Programme 222

Electronically Mapped Cooling System

Design and Function

authorised by Volkswagen AG. Volkswagen AG does not guarantee or accept any liability

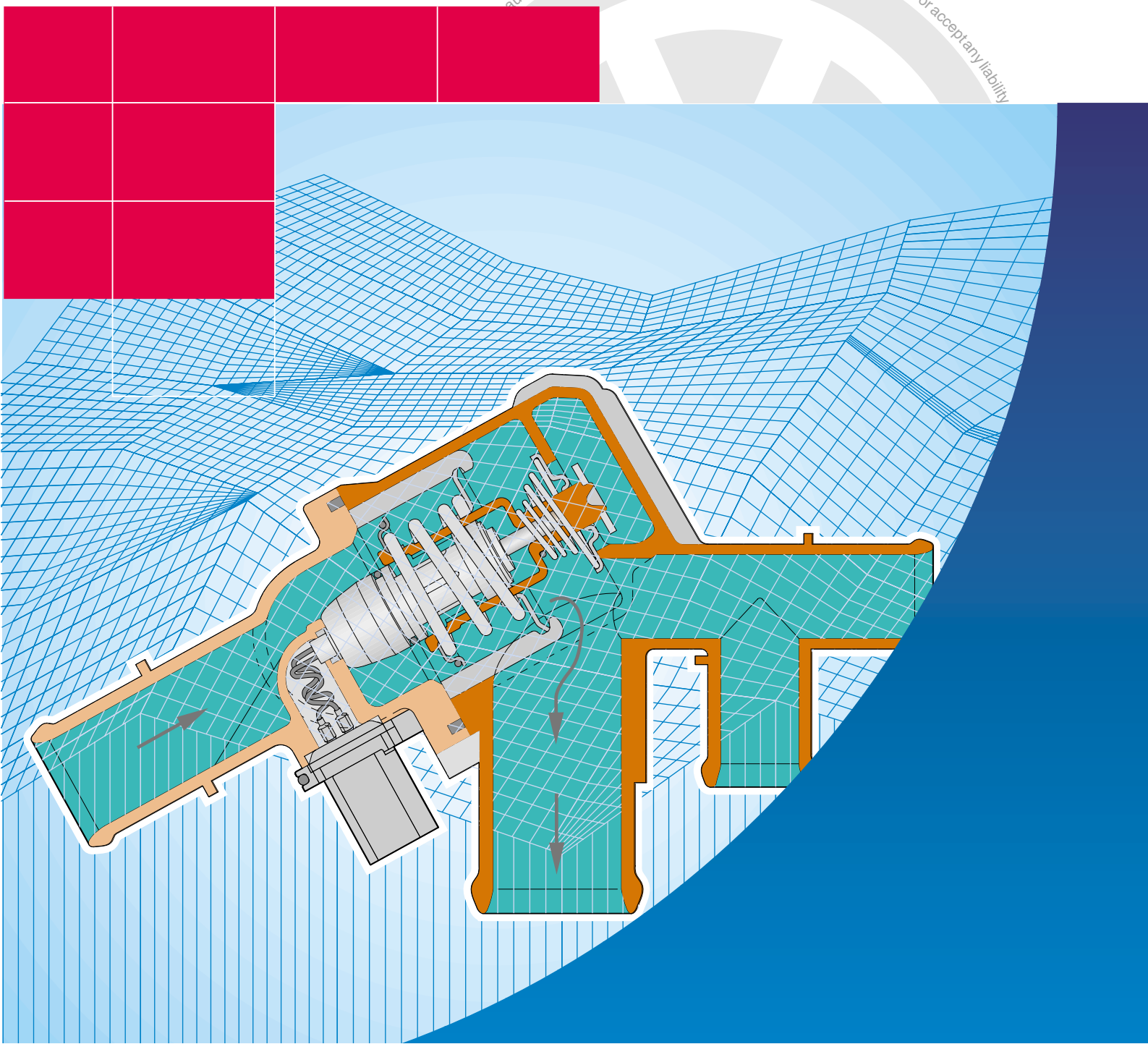

Electronically controlled cooling system

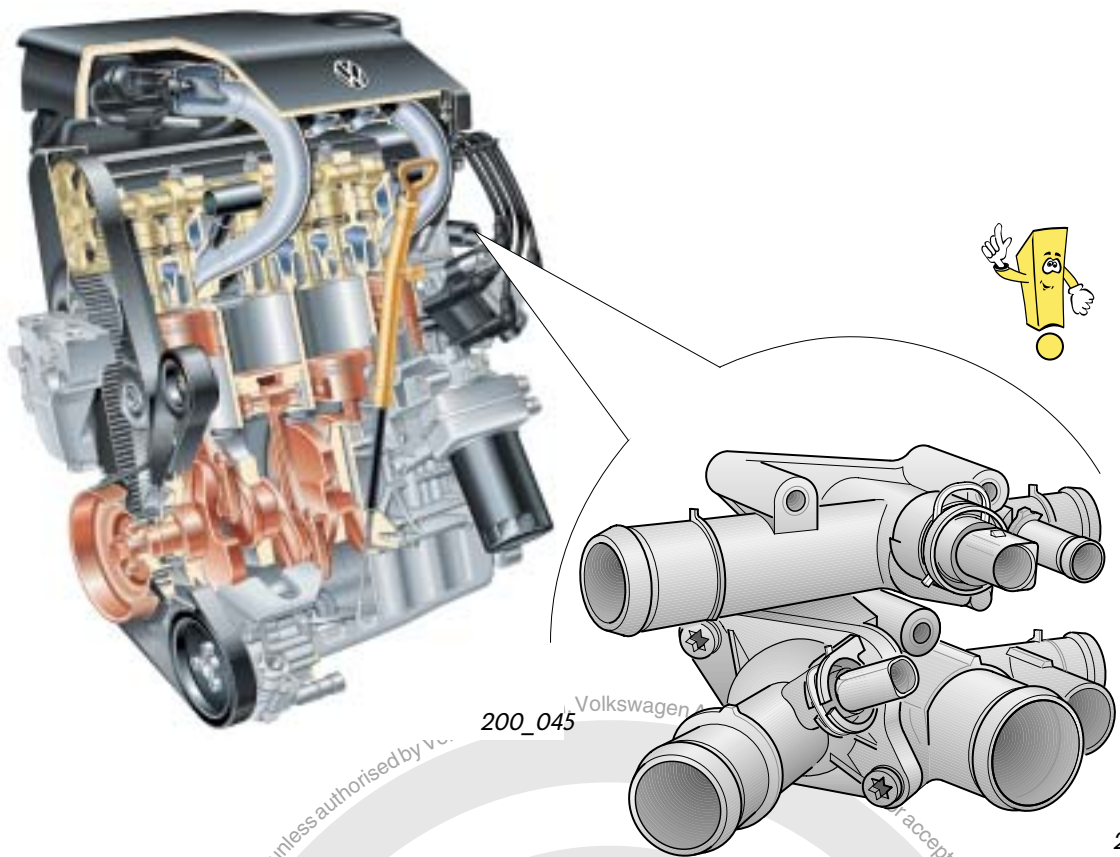

The 1.6-litre 4-cylinder in-line engine (code APF) with a power output of 74 kW is the first engine in which the newly developed

electronically mapped cooling system

will be used. Further engines are in preparation. Load-dependent temperature setpoint input, thermostatic control of coolant temperature and fan cut-in control are the special features of the new system.

The advantages of adapting the coolant temperature to the current operating state are:

- greater fuel economy in the part-throttle range
- reduction of raw CO and HC emissions

This Self-Study Programme describes the design and function of this technical innovation.

The Self-Study Programme is not a Workshop Manual!

Please always refer to the relevant Service Literature for all inspection, adjustment and repair instructions. Service Literature.

New



Important Note

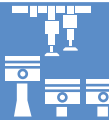

Table of contents



Protected by copyright. Copying for private or commercial purposes, in part or in whole, is not permitted unless authorised by Volkswagen AG. Volkswagen AG does not guarantee or accept any liability with respect to the correctness of information in this document.

General information	4
Cooling the engine with water The coolant temperature level Electronically controlled cooling system	
Main components	8
Coolant distributor housing Coolant control unit	
Cooling circuit	10
Small cooling circuit Large cooling circuit	
Electrical function	14
System overview Simos 3.3 engine management system The coolant temperature sender Thermostat for mapped engine cooling F265 Electrical cooling fan activation Function diagram	
Self-diagnosis	24
Test your knowledge	25



General information

Cooling the engine with water

– What's the reason for cooling?

Let's look at the history.

The temperatures produced during fuel combustion (up to 2000°C) are harmful to the engine.

The engine is therefore cooled down to “operating temperature”.

The first water-based method used was the thermo-syphon cooling process. The heated - and therefore lighter - water rises up a collecting pipe and into the upper part of the radiator. The water is then cooled by the headwind streaming around the radiator. This causes the water to drop down and flow back into the engine. Flow in this circuit runs as long as the engine is running. The cooling process was fan-assisted. Temperature control was still not possible. The water circulation rate was later increased by means of a water pump.

Weak-points:

- Long warm-up period
- Low engine temperature during the cold season

A coolant control, or thermostat, later came into use as engine technology advanced.

The temperature of the water circulating through the radiator is controlled depending on the coolant temperature.

This process was described in 1922 as follows:
These devices serve to raise engine temperature quickly and prevent it from cooling.

This “thermostat-controlled” cooling system had the following functions:

- short warm-up period
- maintenance of a constant operating temperature.

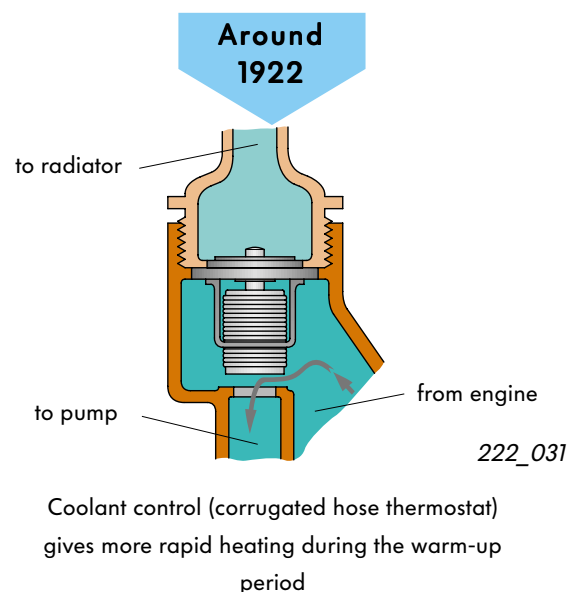
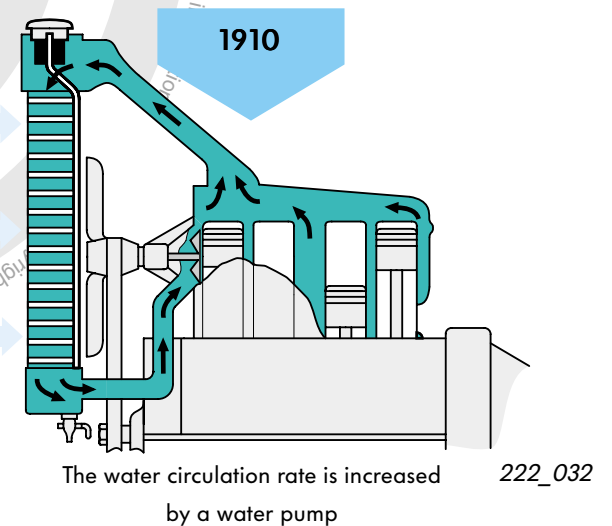
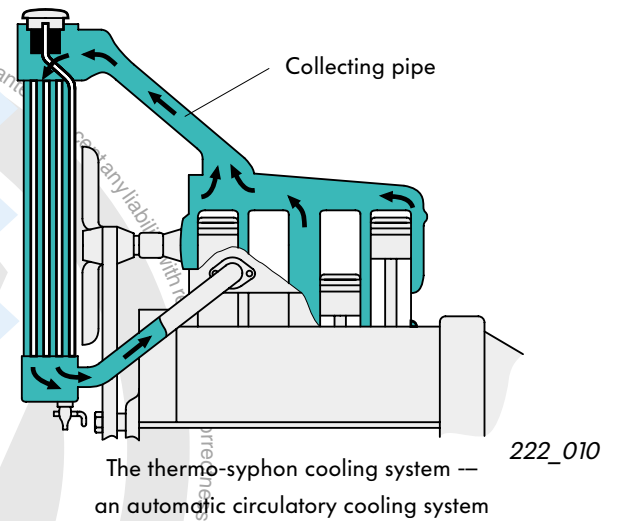

The thermostat, therefore, was a major improvement and made possible the so-called “bypass water line“. As long as the engine has not reached the desired operating temperature, the water does not flow through the radiator rather it flows back into the engine along a short path. This control concept is still used today in all systems.

The chart on the right shows the effect of engine temperature on power output and fuel consumption.

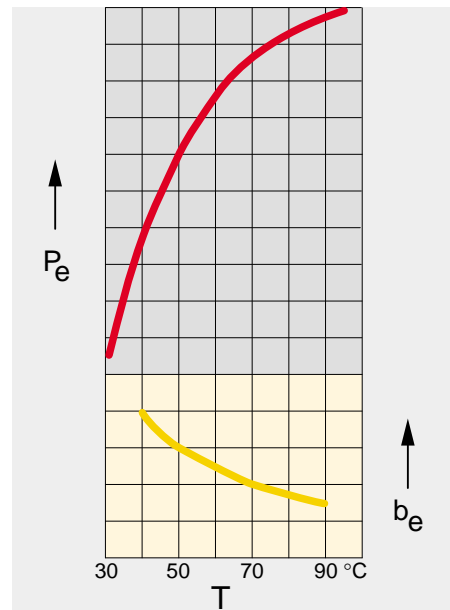

P_e = power output
 b_e = fuel consumption
 T = engine temperature

222_012



However, the correct engine operating temperature is nowadays important not only for power output and consumption; it is also essential for low pollutant emissions.

Engine cooling is based on the principle that pressurised water starts to boil at temperatures between 115°C to 130°C and not at 100°C.

The cooling circuit is subject to a pressure of 1.0 - 1.5 bar. This is known as a “closed-circuit cooling system“.

For this purpose, the system has an expansion tank which is only half full.

The corrugated hose thermostat has been replaced by an elastic thermostat (waxstat).

The cooling medium is not only water but a mixture of water and coolant additive. This mixture offers frost protection, has a higher boiling point and protects light-alloy parts of the engine against corrosion.

Standard today

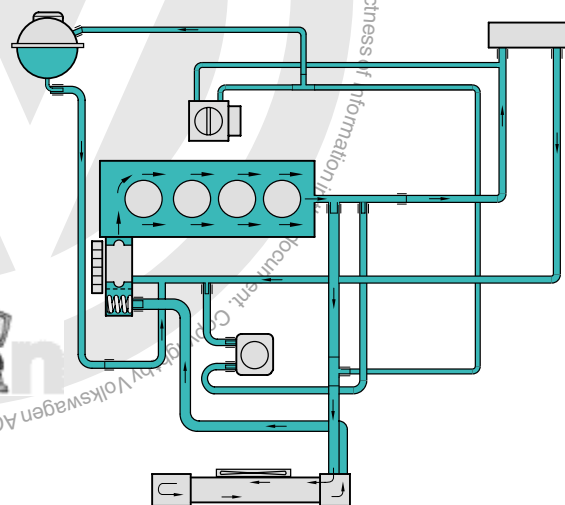

222_014

Closed-circuit cooling system with elastic thermostat and expansion tank filled with coolant

General information

The coolant temperature level

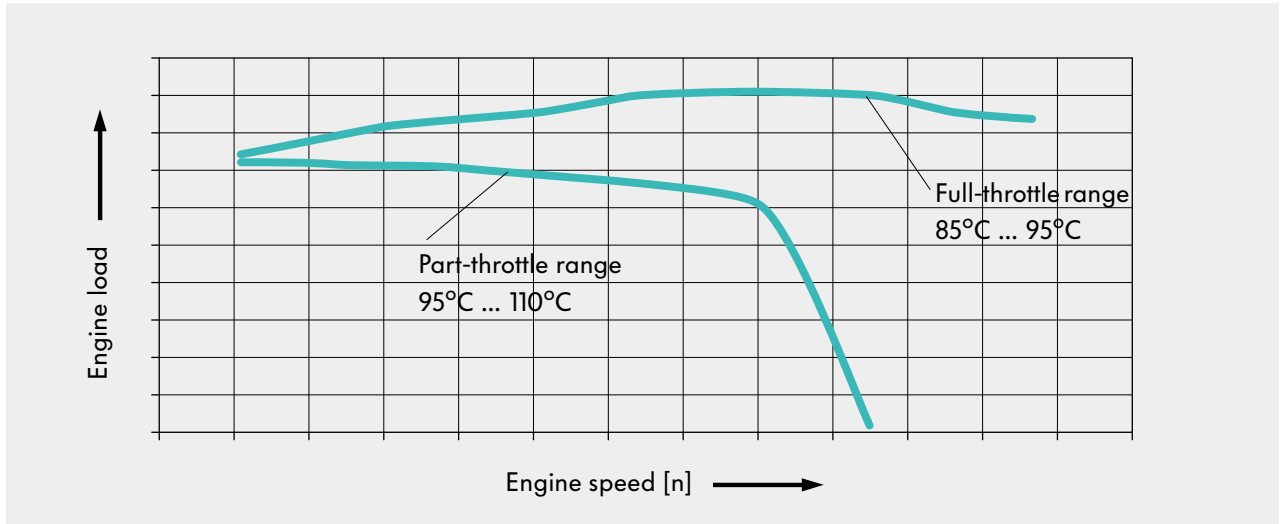
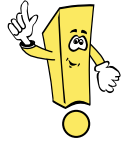

Coolant temperature level as a function of engine load with mapped cooling

222_013



Engine load and cooling should always be regarded in context.

Engine performance is dependent on proper engine cooling.

In the thermostat-controlled cooling system, the coolant temperatures range from 95°C to 110°C in the part-throttle range and from 85°C to 95°C in the full-throttle range.

- Higher temperatures in the part-throttle range improve performance, which in turn reduces consumption and pollutants in the exhaust gas.
- Lower temperatures in the full-throttle range increase power output. The induced air is heated to a lesser degree, boosting performance.

Electronically controlled cooling system

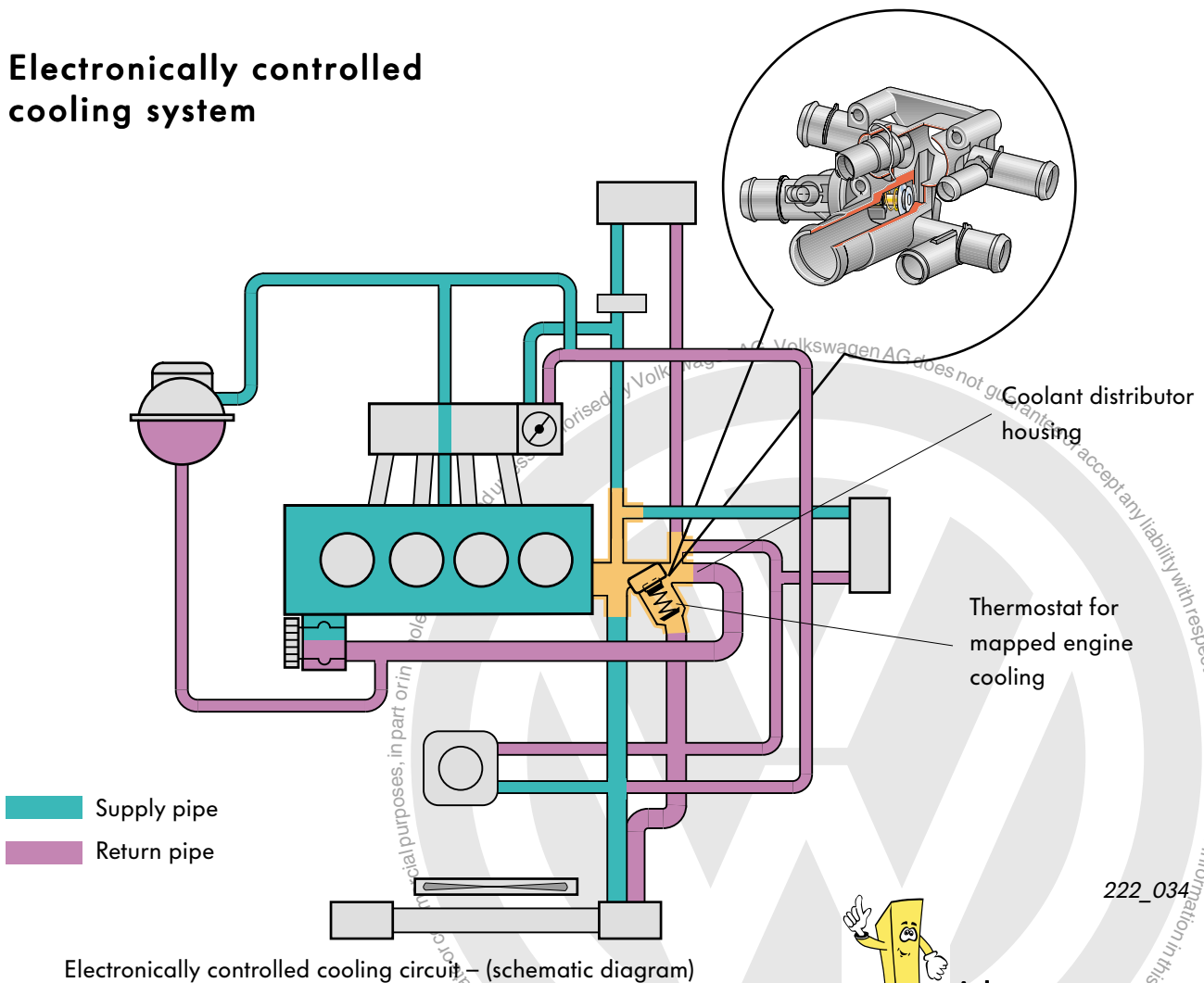

Advantages

The aim of developing an electronically mapped cooling system was to set the operating temperature of the engine to a specified value depending on the load state.

An optimal operating temperature is set according to maps stored in the engine control unit via the thermostat to be heated electrically and the radiator fan settings.

Cooling can thus be adapted to the engine's overall performance and load state.

The advantages of adapting the coolant temperature to the current operating state of the engine are as follows:

- Lower consumption in the part-throttle range
- Reduced raw CO and HC emissions

Changes to the conventional cooling circuit:

- Integration in the cooling circuit through minimal design modifications.
- The coolant distributor housing and thermostat are combined to form a single unit.
- There is no longer any need for a coolant thermostat on the engine block.
- The engine control unit also contains the maps of the electronically mapped cooling system.

Main components

Coolant distributor housing

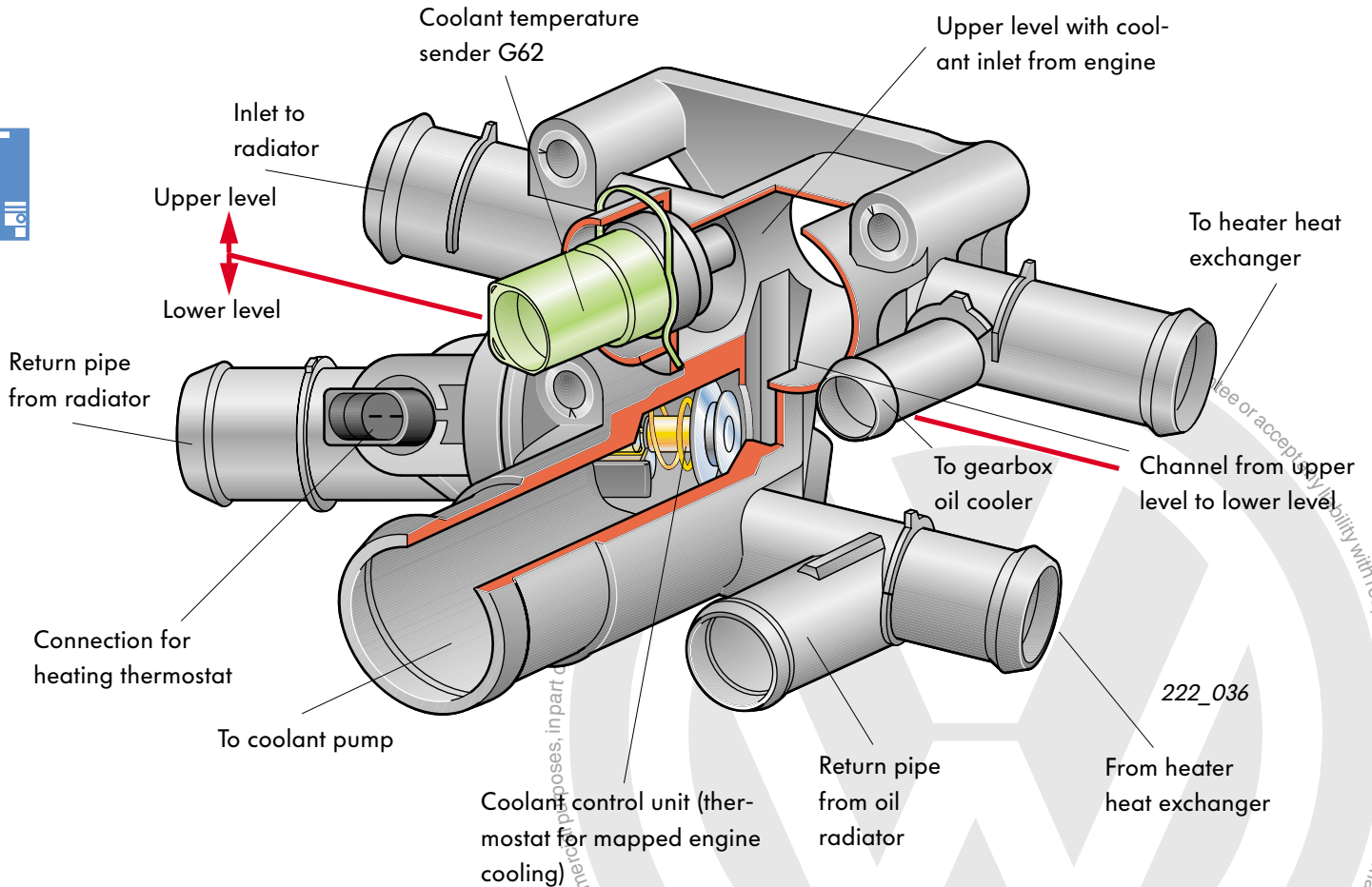

The coolant distributor housing is mounted directly on the cylinder head instead of the connection stub.

Let's have a look at it at two levels.

The individual components are supplied with coolant from the upper level. An exception to this is the supply to the coolant pump.

The coolant return pipe from the individual components is connected at the lower level of the distributor housing.

An upright channel connects the upper and lower levels. The thermostat opens and closes the upright channel by means of its small valve disc.

The coolant distributor housing is in fact the distributor station which distributes the coolant to the large cooling circuit or small cooling circuit.

Coolant control unit (Thermostat for mapped engine cooling)

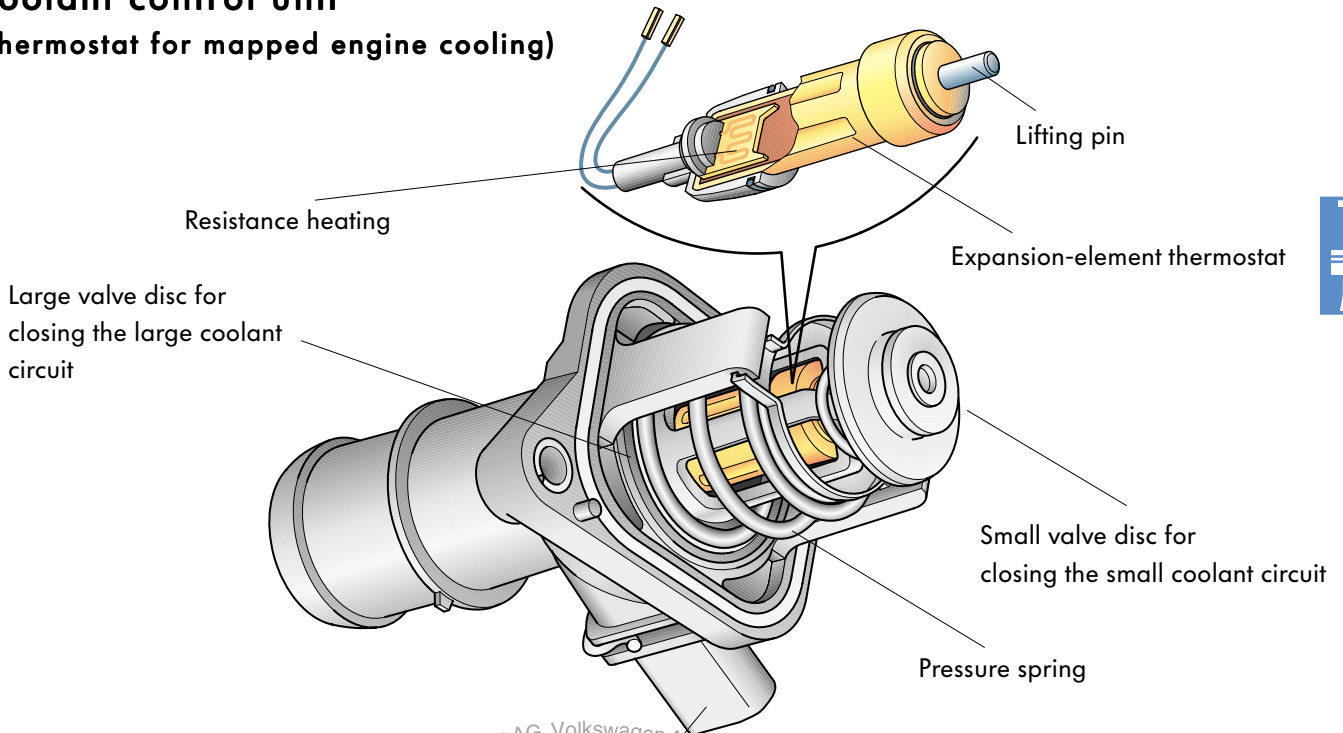

Connection between expansion-element thermostat and heating

222_035

The functional components

- Expansion-element thermostat (with wax thermo-couple)
- Resistance heating in wax thermo-couple
- Pressure springs for mechanically closing the coolant ducts
- 1 large valve disc and 1 small valve disc

Function

The expansion-element thermostat in the coolant distributor housing is permanently immersed in coolant.

The wax thermo-couple regulates the temperature unheated - as before - but is rated for a different temperature.

The coolant temperature causes the wax to liquefy and expand, producing a lifting movement of the lifting pin.

This normally happens without the application of a flow in accordance with the new coolant temperature profile of 110°C at the engine block outlet.

A heating resistor is integrated in the wax thermo-couple. When energised, the heating resistor heats the wax thermo-couple additionally and the stroke - i.e. adjustment - is performed not only as a factor of the coolant temperature, but as specified by the map stored in the engine control unit.

Cooling circuit

Small cooling circuit

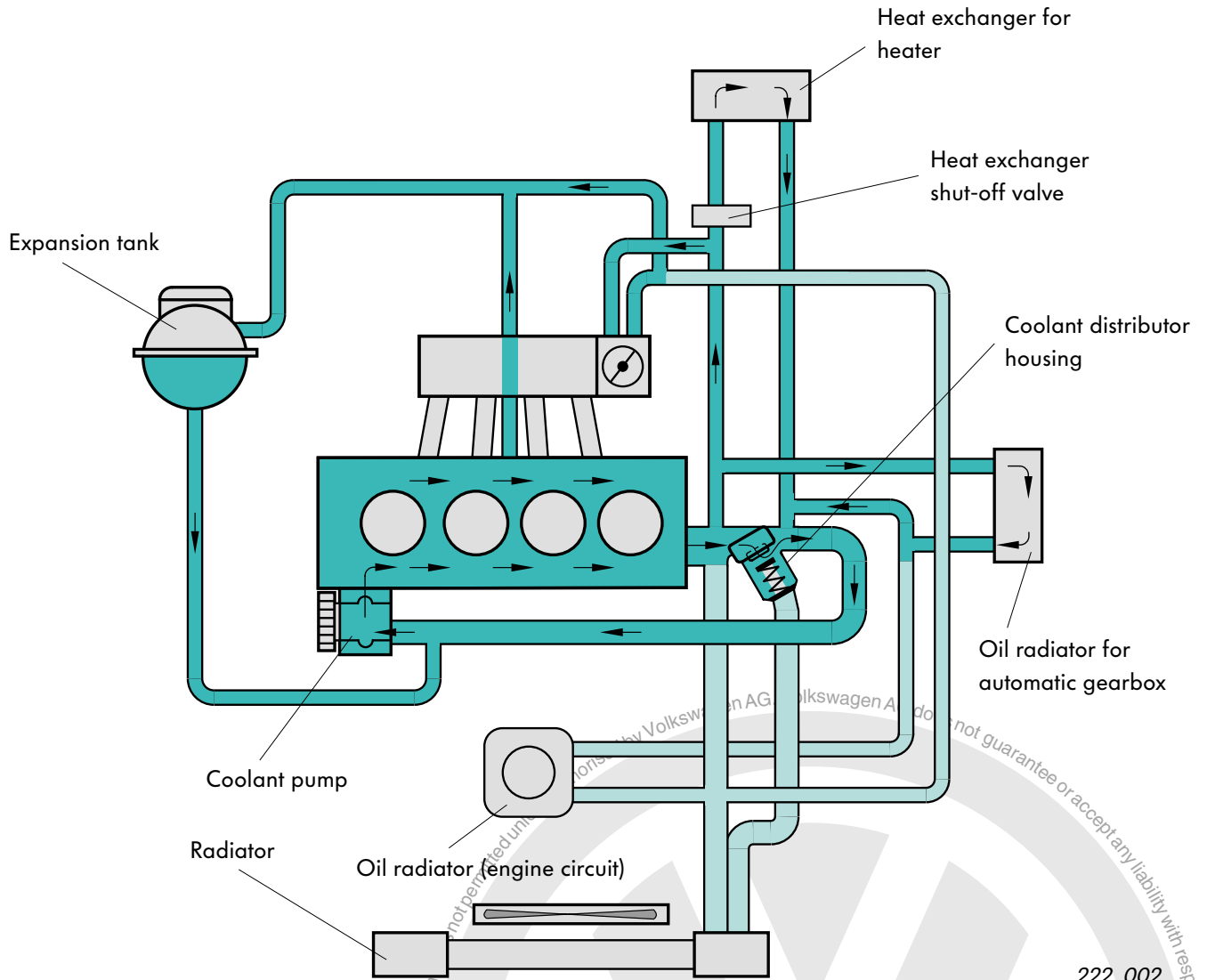

Engine – cold starting and part throttle

The small cooling circuit helps to heat up the engine quickly.

The mapped engine cooling function does not come into play yet.

The thermostat in the coolant distributor housing has shut off the return pipe from the radiator and opened the short path to the coolant pump. The radiator is not integrated in the coolant circulation system.

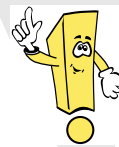

Temperature level in small circuit for heating the engine for the lower and upper part-throttle ranges from 95°C to 110°C

Cooling circuit

Large cooling circuit

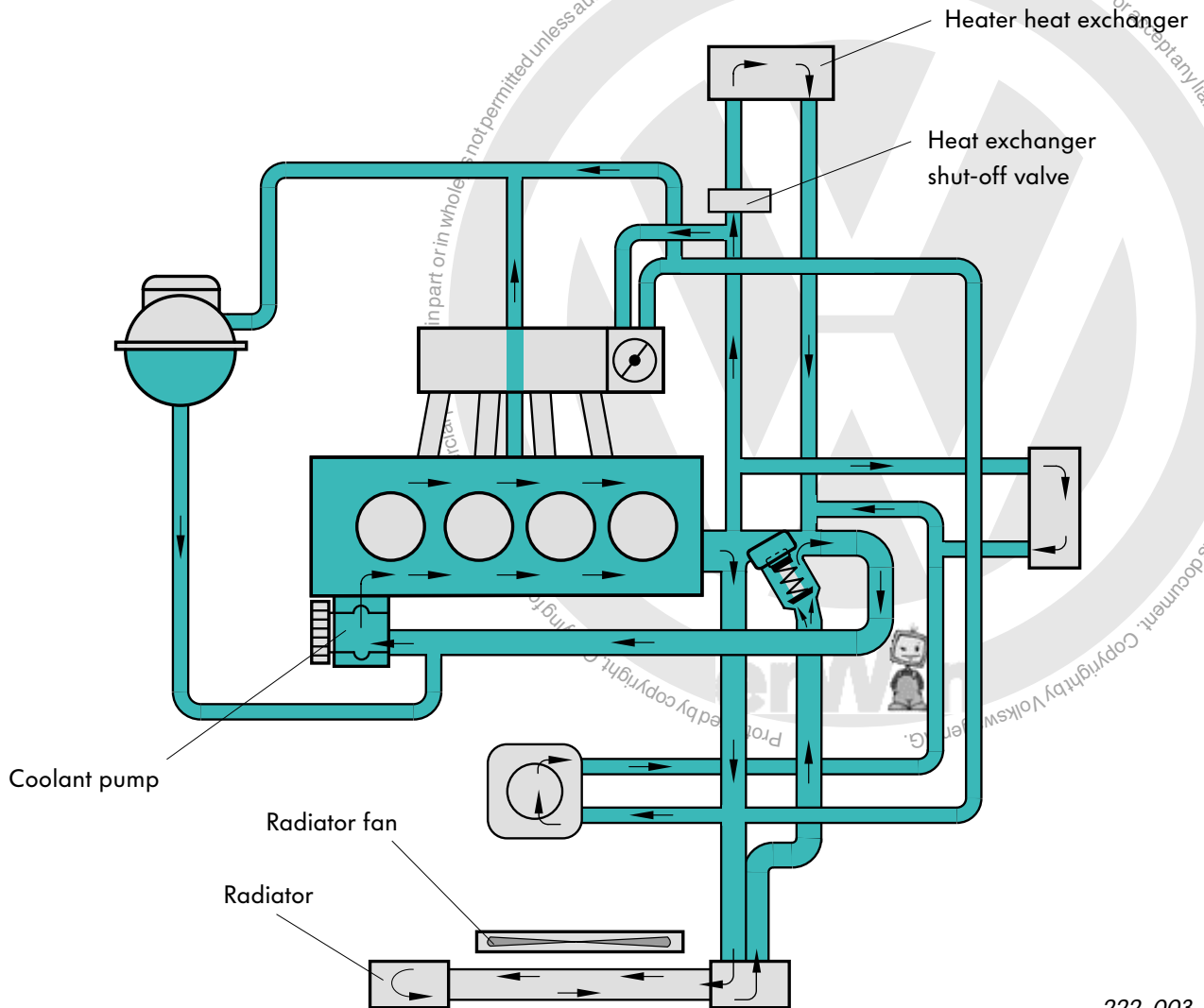

222_003

The large cooling circuit is opened either by the thermostat in the coolant thermostat after reaching a temperature of approx. 110°C or by a map depending on the load.

The radiator is now integrated in the coolant circulation system.

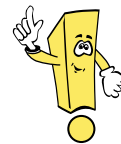

Temperature level in large circuit under full throttle 85°C to 95°C

Electric fans are switched on as required to provide additional cooling to boost the effect of headwind or at idle.

Function of large cooling circuit

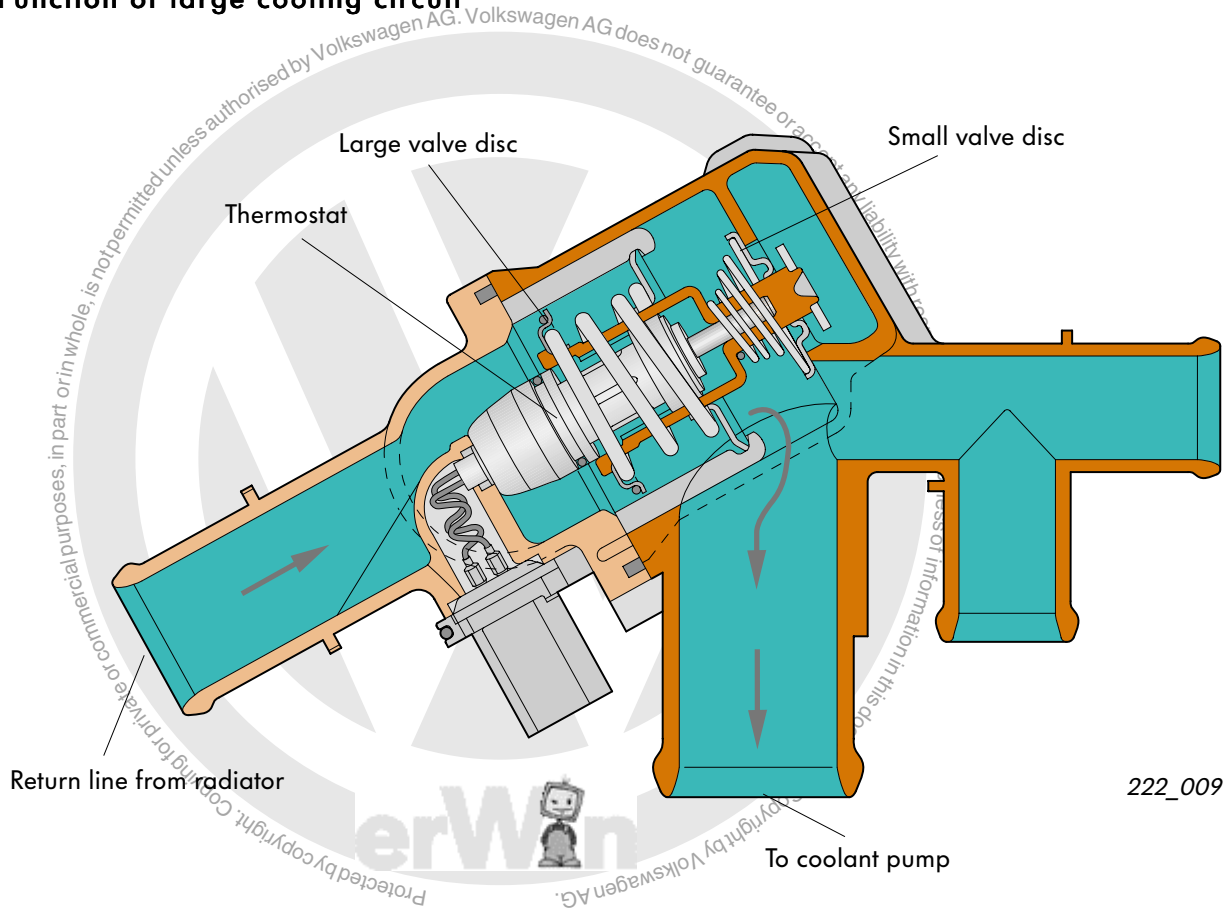

Engine – full throttle

When the engine is at full throttle, a high cooling capacity is required. A current is applied to the thermostat in the coolant distributor housing, causing the return line from the radiator to open.

The small cooling circuit from the small valve disc to the coolant pump is closed simultaneously because they are coupled mechanically.

The coolant pump feeds the coolant to the radiator via the upper level after it is discharged from the cylinder head.

Having been cooled, the coolant flows back from the radiator into the lower level and is again drawn in by the coolant pump.

Intermediate stages are also possible.

A certain portion of the coolant then runs into the large cooling circuit and another portion runs into the small cooling circuit.



Electrical function

System overview

Sensors

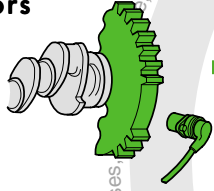

Engine speed sender G28

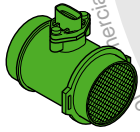

Air-mass flow meter G70 with intake air temperature sender G42

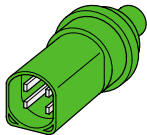

Coolant temperature sender G62

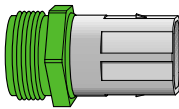

Radiator outlet coolant temperature sender G83

Potentiometer for rotary temperature selection knob G267

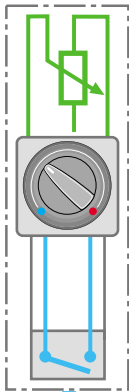

Temperature flap position switch F269

Simos 3.3 J361 control unit

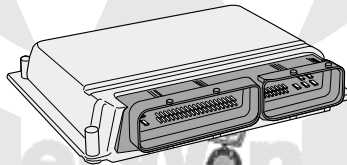

CAN

Diagnostic connection

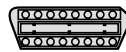

Road speed signal from ABS control unit J104

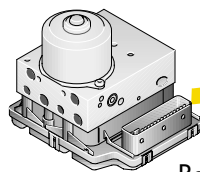

Actuators

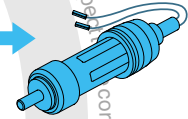

Thermostat for mapped engine cooling F265

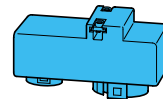

Radiator fan control unit J293



Radiator fan V7



Radiator fan -2- V177

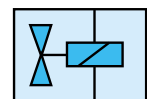

Coolant cut-off valve two-way valve N147

222_020

Simos 3.3 engine management system

Design

Functions are specially integrated in the Simos 3.3 engine management system for the electronically mapped cooling system.

Several maps are relevant:

- Specified coolant temperature 1 (dependent on the engine speed and engine load)
- Specified coolant temperature 2 (dependent on road speed and intake air temperature)
- Pre-control pulse duty factor (dependent on specified temperature and engine speed)
- Temperature difference via radiator for fan, 1st speed (dependent on air mass, load and engine speed)
- Temperature difference for fan, 2nd speed (dependent on air mass, load and engine speed)

The engine control unit functionality has been extended to include connections for the sensors and actuators of the electronically mapped cooling system:

- Application of current to thermostat (output)
- Radiator return flow temperature (input)
- Radiator fan control (2 outputs)
- Potentiometer at heater controls (input)

The sensors of the engine control unit are used to obtain all the information otherwise required.

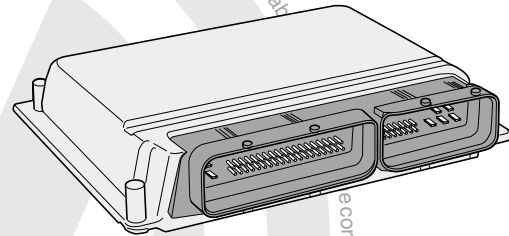

222_022

Function

The map temperature functions are calculated every second.

The system is controlled based on the results of the function calculations:

- Activation (application of flow) of the heating resistor in the thermostat for mapped engine cooling for opening the large cooling circuit (regulating coolant temperature).
- Activation of the cooling fan to support a quick coolant temperature reduction.

Self-diagnosis

The electronically mapped cooling system is integrated in the self-diagnosis.



Electrical function

Regulation of coolant temperature when driver operates heating

Potentiometer G 267 on rotary knob for temperature selection

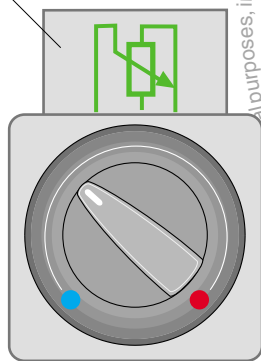

222_037

The coolant temperature can fluctuate between 110°C and 85°C when the vehicle is driven between partial and full load.

A temperature difference of 25°C would be noticed as uncomfortable in the vehicle interior if the heating were on. The driver would then "re-adjust" constantly.

Thanks to the potentiometer G267 the cooling system electronics recognises the driver's requested temperature and regulates the coolant temperature accordingly, e.g. rotary knob position 70% to 95°C coolant temperature.

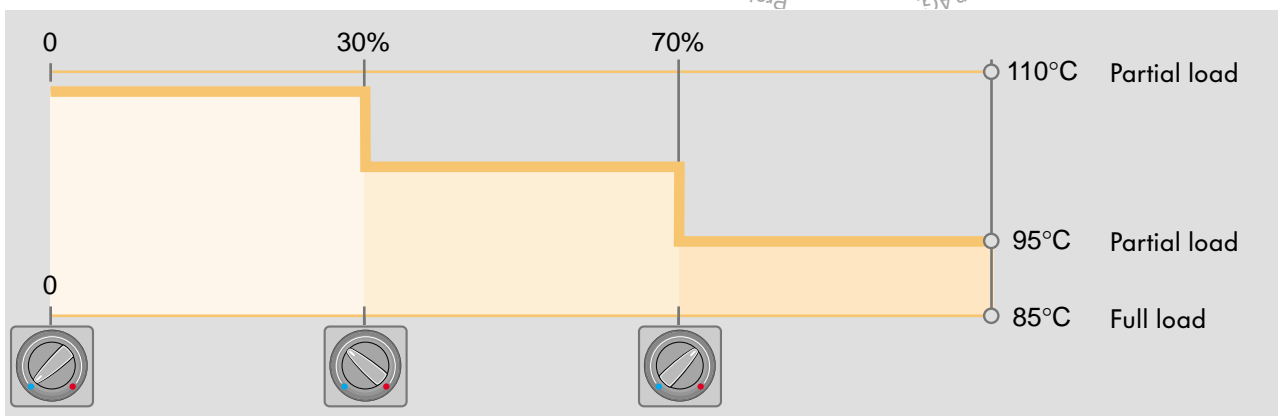

222_038

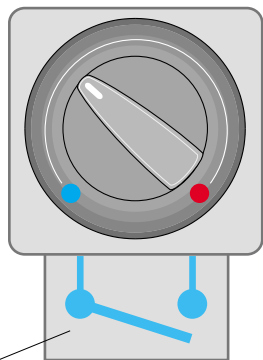

222_039

Micro-switch on rotary knob for temperature selection

A micro-switch on the temperature selection rotary knob opens as soon as the "Heating off" position is abandoned.

This activates a pneumatic two-way valve N147 which opens the coolant shut-off valve for the heater heat exchanger and is activated by vacuum.

The coolant temperature setpoints

Activation of the thermostat for mapped engine cooling (large cooling circuit or small cooling circuit) is regulated by maps.

The relevant temperature setpoints are stored in these maps.

The engine load is the decisive factor.

The coolant temperature to be set is calculated from the engine load (air mass) and engine speed.

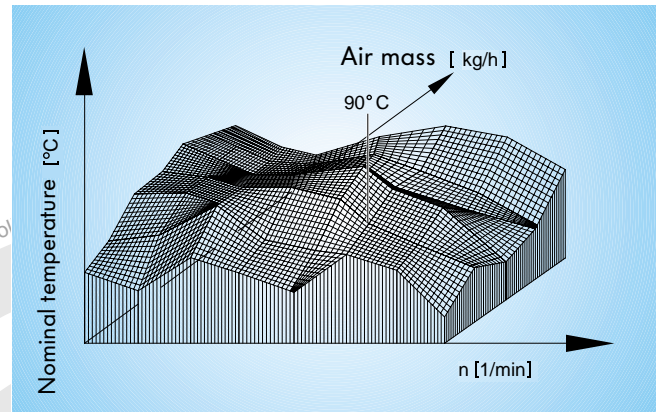

222_016

Map - specified temperature 1 dependent on engine speed (n) and engine load (air mass in kg/h)

Temperature setpoints are stored in dependence on road speed and intake air temperature in a second map. The required coolant temperature setting is calculated from these variables.

By comparing maps 1 and 2, the lower value is utilised as the setpoint and the thermostat is set accordingly.

The thermostat is not activated until a temperature threshold has been exceeded and the coolant temperature is just below the setpoint.

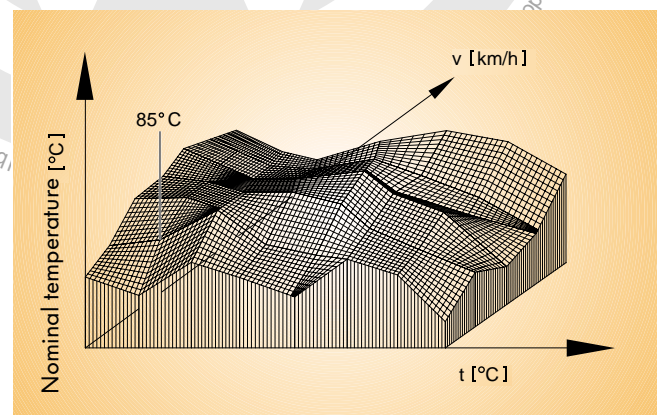

222_017

Map - specified temperature 2 dependent on road speed (v) and intake air temperature (t)



Electrical function

The coolant temperature sender

Temperature senders G62 and G83 operate as NTC senders. The coolant temperature setpoints are stored in the engine control unit in the form of maps.

The actual coolant temperature values are registered at two different points in the cooling circuit and indicated to the control unit in the form of a voltage signal.

- ① **Coolant actual value 1**
directly at the coolant outlet in the coolant distributor on the engine.
- ② **Coolant actual value 2**
at the radiator before coolant discharge from the radiator.

Signal utilisation

Comparison of the specified temperatures stored in the maps with the actual temperature ① gives the pulse duty factor for the application of current to the heating resistor in the thermostat.

Comparison of the coolant actual values ① and ② is the basis for activation of the electrical radiator fan.

Substitute function

If coolant temperature sender G62 fails, a defined substitute value of 95°C is used for coolant temperature control and the 1st fan speed stays activated.

If coolant temperature sender G83 fails, the control function remains active and the 1st fan speed stays activated.

If a certain temperature threshold is exceeded, the 2nd fan speed is activated.

If both senders fail, maximum voltage is applied to the heating resistor and the 2nd fan speed stays activated.

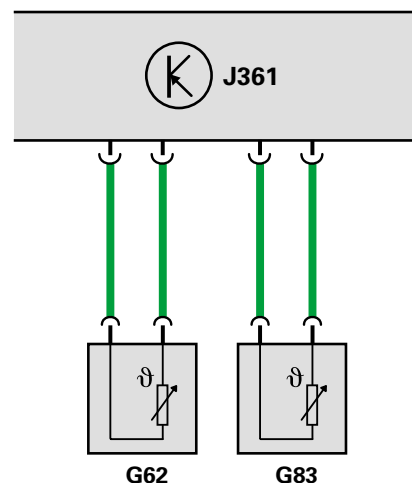
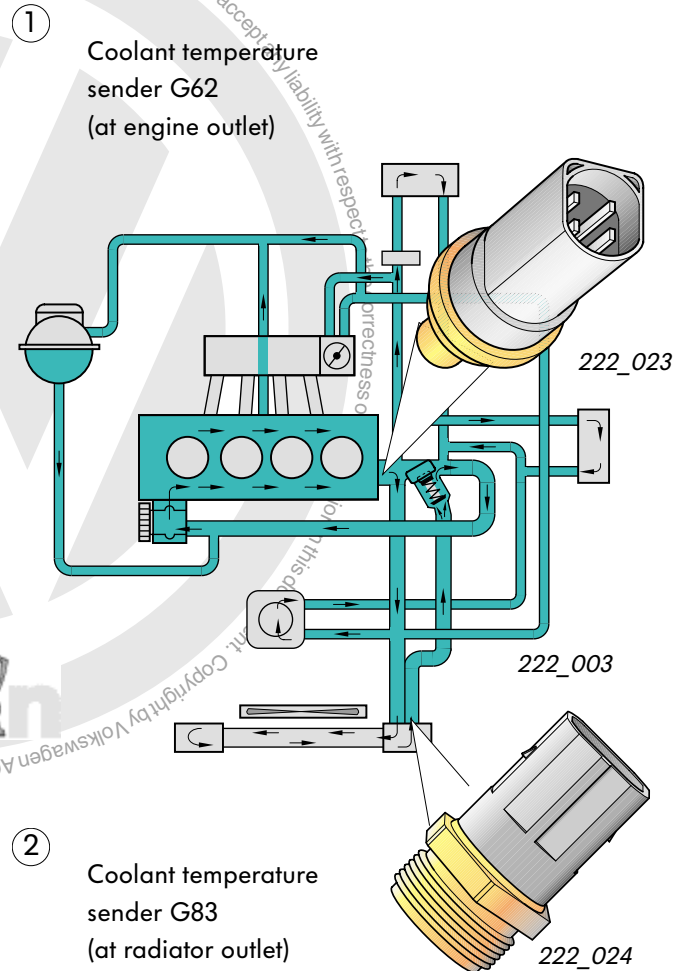

222_030

Thermostat for mapped engine cooling F265

A heating resistor is integrated in the wax thermo-couple of the expansion-element thermostat.

This resistor additionally heats the wax, which expands causing the lifting pin to execute stroke "x" in accordance with the map. The thermostat is adjusted mechanically via stroke x.

The heating is activated by the engine control unit in accordance with the map via a PWM (pulse-width modulated) signal.

The extent of heating varies depending on pulse width and time.



No voltage is applied when the engine is stationary or during the engine starting cycle.



The purpose of the thermostatic heating system is not to heat the coolant. It heats the thermostat in a controlled manner in order to open the large cooling circuit.

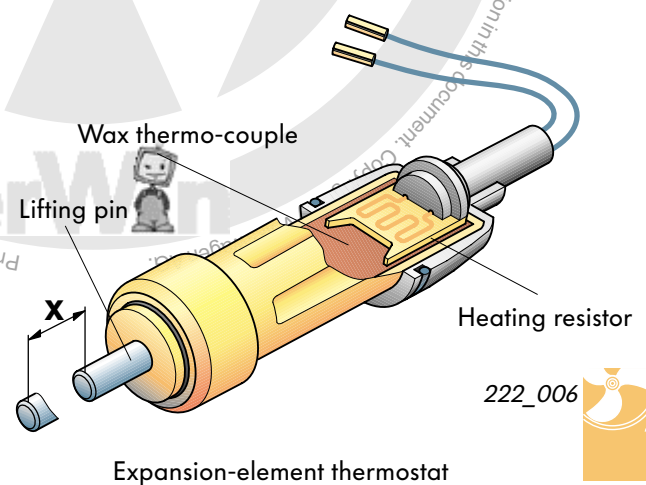

Rule:

PWM low (without voltage) = high coolant temperature

PWM high (with voltage) = low coolant temperature

No operating voltage

Control takes place only by means of expansion element. The 1st fan speed is continuously activated.

Electrical circuit

D/15 Ignition lock terminal 15

D/30 Ignition lock terminal 30

F265 Thermostat for mapped engine cooling F265

J363 Power supply relay for Simos control unit

J361 Simos control unit

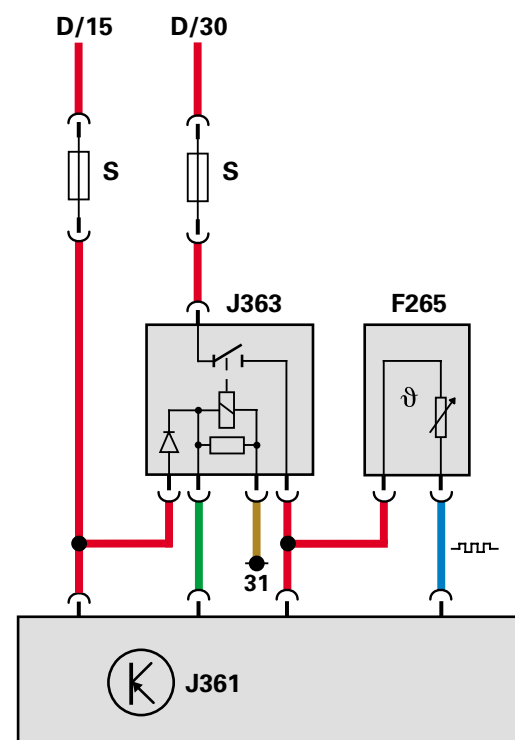

222_007



Electrical function

Coolant temperature level (frequency in %) for thermostat-based cooling (as used until now) and for mapped engine cooling

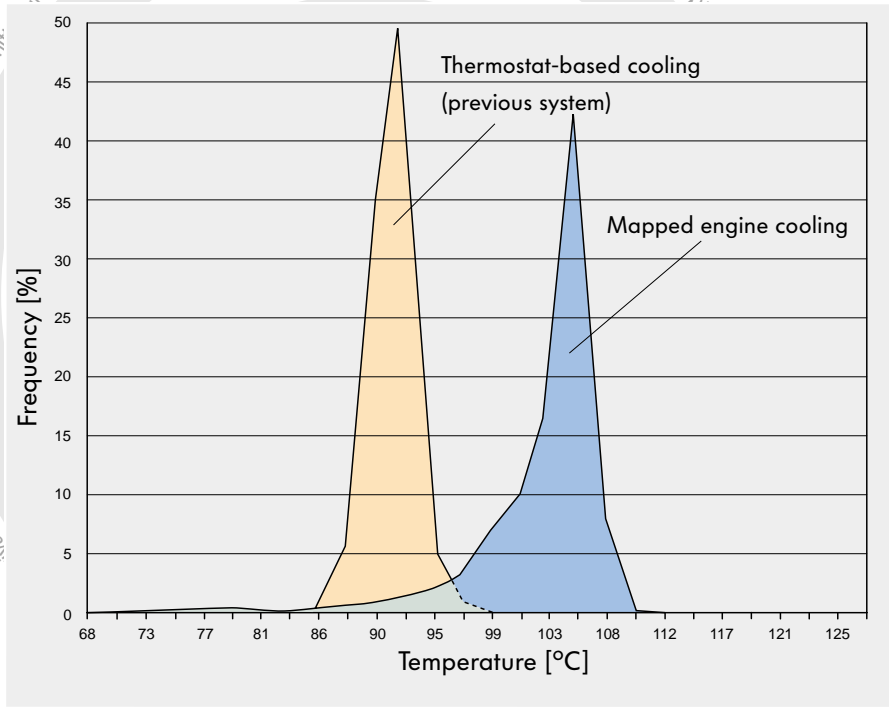

Coolant temperature at engine outlet

222_019

The thermostat regulates the coolant temperature at a design-defined point in much the same way as a standard expansion-element thermostat without electric current (temperature at engine outlet: 110°C).

The pre-control pulse duty factor is stored in a separate map.

The map is required to achieve the temperature setpoint.

The information required for this purpose is obtained by comparing the actual temperature and the specified temperature as a factor of engine speed.

A temperature constant of 85°C to 110°C can be set depending on engine load.

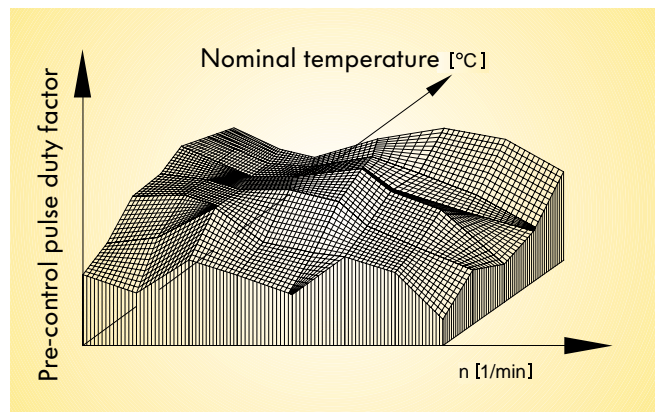

222_018

Map, pre-control pulse duty factor (dependent on engine speed and specified temperature)

Activation of the electrical cooling fan

The low temperature (full-throttle mode) is heavily dependent on the current cooling capacity.

To increase the cooling capacity, the engine control unit can also activate the two speed settings of the radiator fan motor.

The fan is controlled (first or second fan speed) depending on the temperature difference of the coolant between the engine outlet and the radiator outlet.

The cut-in and cut-out conditions for the fans are stored in 2 maps in the engine control unit which allow for these conditions. Both maps are dependent on engine speed and air mass (engine load).



The fan does not cut in at road speeds above 100 kph, because the fan does not provide additional cooling at speeds higher than this.

Substitute function

If faults occur in the circuit of the 1st fan output stage, the 2nd stage is activated by way of a substitute.

If faults occur in the 2nd fan output stage, the thermostat for mapped engine cooling is fully energised (safety factor).

Run-on

Radiator fan run-on after turning off the engine is time- and temperature-dependent.

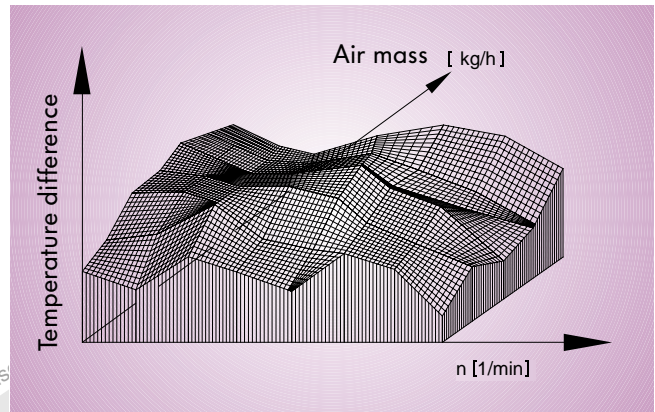

222_026

Map 1 - Temperature difference for fan speed 1

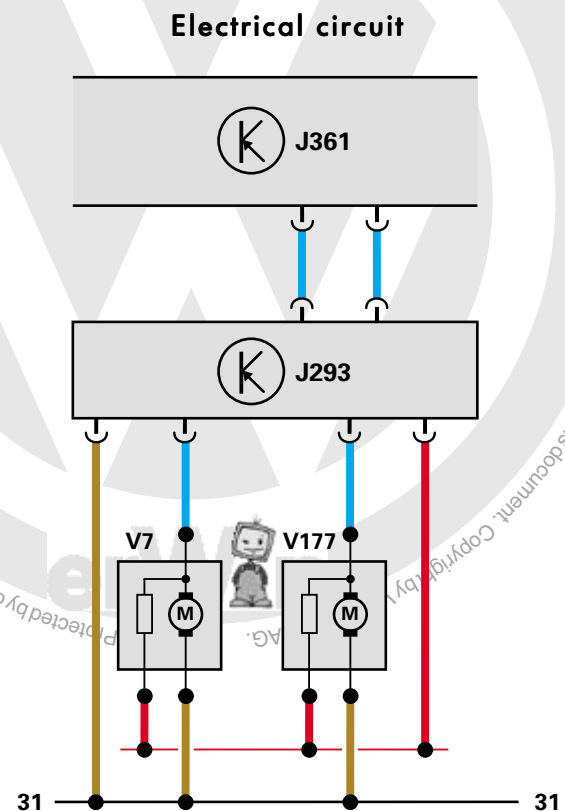

222_025



On vehicles with towbar or with air conditioning, two fan motors are fitted (larger cooling circuit).



Electrical function



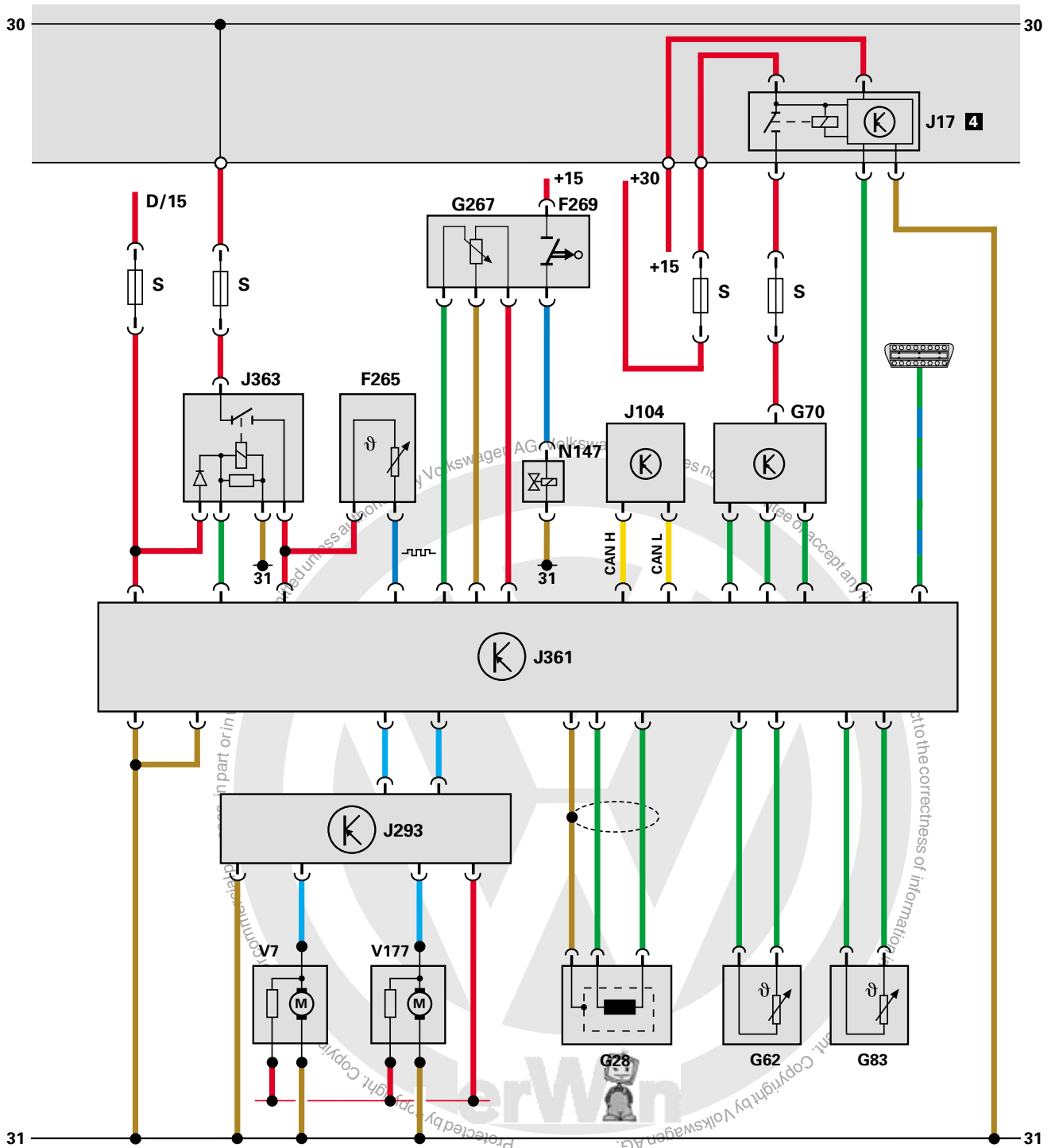



Function diagram



222_021

Function plan legend:

Colour coding

-  = output signal
-  = input signal
-  = positive
-  = ground
-  = bidirectional
-  = PWM signal
-  = diagnostic terminal
- +15 = power supply ignition switch output
- +30 = power supply from battery

Legend

- D/15 Ignition switch, terminal 15
- F265 Thermostat for mapped engine cooling
- F269 Switch for setting temperature flap
(not with Climatronic)
- G28 Sender for engine speed
- G62 Sender for coolant temperature
- G70 Air mass meter
- G83 Sender for coolant temperature
at radiator outlet
- G267 Potentiometer for temperature selector
rotary knob (not with Climatronic)
- J17 Fuel pump relay
- J104 Control unit for ABS
- J293 Control unit for radiator fan
- J361 Simos control unit
- J363 Power supply relay for Simos control unit
- N147 Two-way valve for coolant shut-off valve
- S Fuse
- V7 Radiator fan
- V177 Radiator fan -2-



The function plan represents a simplified current flow diagram.

It shows all the links between system components for the electronically mapped cooling system.



Self-diagnosis

The self-diagnosis function of the electronically mapped cooling system is integrated in the engine electronics.

The self-diagnosis monitors the sensors, the actuators and the control unit.

If the control unit detects a fault, it calculates a substitute value from other input signals and provides emergency running functions.

The fault is stored in the fault memory.

In addition, measured values are displayed in the "Read data block" troubleshooting function.

A distinction is made between the following diagnosis cases:

- Failure of coolant temperature sender G62 (engine outlet)
- Failure of coolant temperature sender G83 (radiator outlet)
- Failure of both coolant temperature senders
- Faults in the fan output stages
- Faults in the thermostat output stage

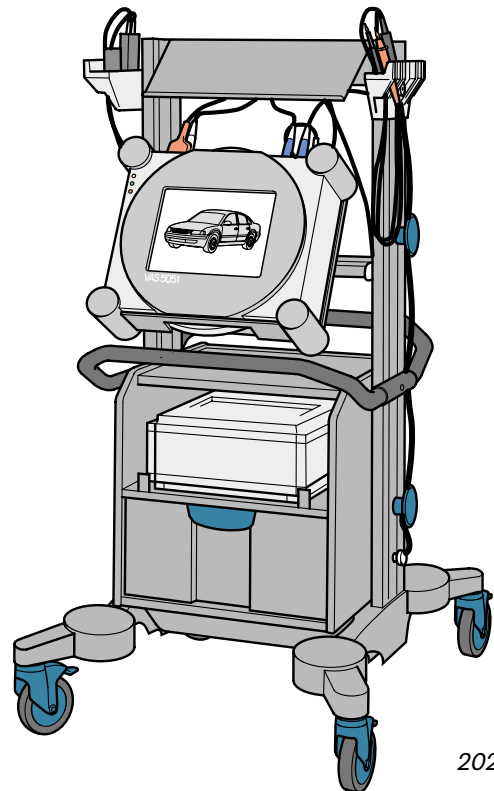

202_002

Self-diagnosis can be performed using the Vehicle Diagnostic, Testing and Information System VAS 5051,

Fault Reader V.A.G 1551 or with Vehicle Systems Tester V.A.G 1552.

For a detailed description of the self-diagnosis procedure, please refer to the Workshop Manual on the 1.6-litre/74 kW engine, Simos injection and ignition system.

Test your knowledge

Which of these answers are correct?
Sometimes only one answer is correct.
However, more than one– or all of the answers
may be right!



222_027

- The differences between engine cooling with an electronically mapped cooling system and thermostat-controlled engine cooling are:
 - the temperature is kept as constant as possible at an optimal level
 - different temperatures under load
 - different temperatures in the full-throttle and part-throttle ranges
- Temperature maps are used for coolant temperature control.
To measure these values,
 - sensors have been added
 - the engine control unit sensors have been incorporated
- The radiator fan does not cut in above a specific road speed, because it no longer provides additional cooling. This speed is:
 - 125 kph
 - 115 kph
 - 100 kph
- The engine control unit determines the actual engine temperature
 - from the signals from the two coolant temperature senders
 - from the signal from coolant sender G62
 - from the signal from the coolant sender and the signal from the knock sensor
- The coolant temperature level in full-throttle mode
 - is between 70 and 80°C
 - between 85 and 95°C
 - between 70 and 95°C
- The temperature of the coolant under part throttle
 - is between 95 and 110°C
 - is kept at a constant 110°C
 - is kept at a constant 115°C
- The cooling fan provides additional cooling. The radiator fan is controlled according to
 - the actual coolant temperature
 - the actual temperature at the radiator
 - the temperature difference between the engine outlet and the radiator outlet
- The thermostat is disconnected from the power supply
 - during the starting cycle
 - when the engine is stationary
 - at high coolant temperatures



Protected by copyright. Copying for private or commercial purposes in part or in whole, is not permitted unless authorized by Volkswagen AG. Volkswagen AG does not guarantee or accept any liability with respect to the content of this document. Information in this document. Copyright by Volkswagen AG.

Note





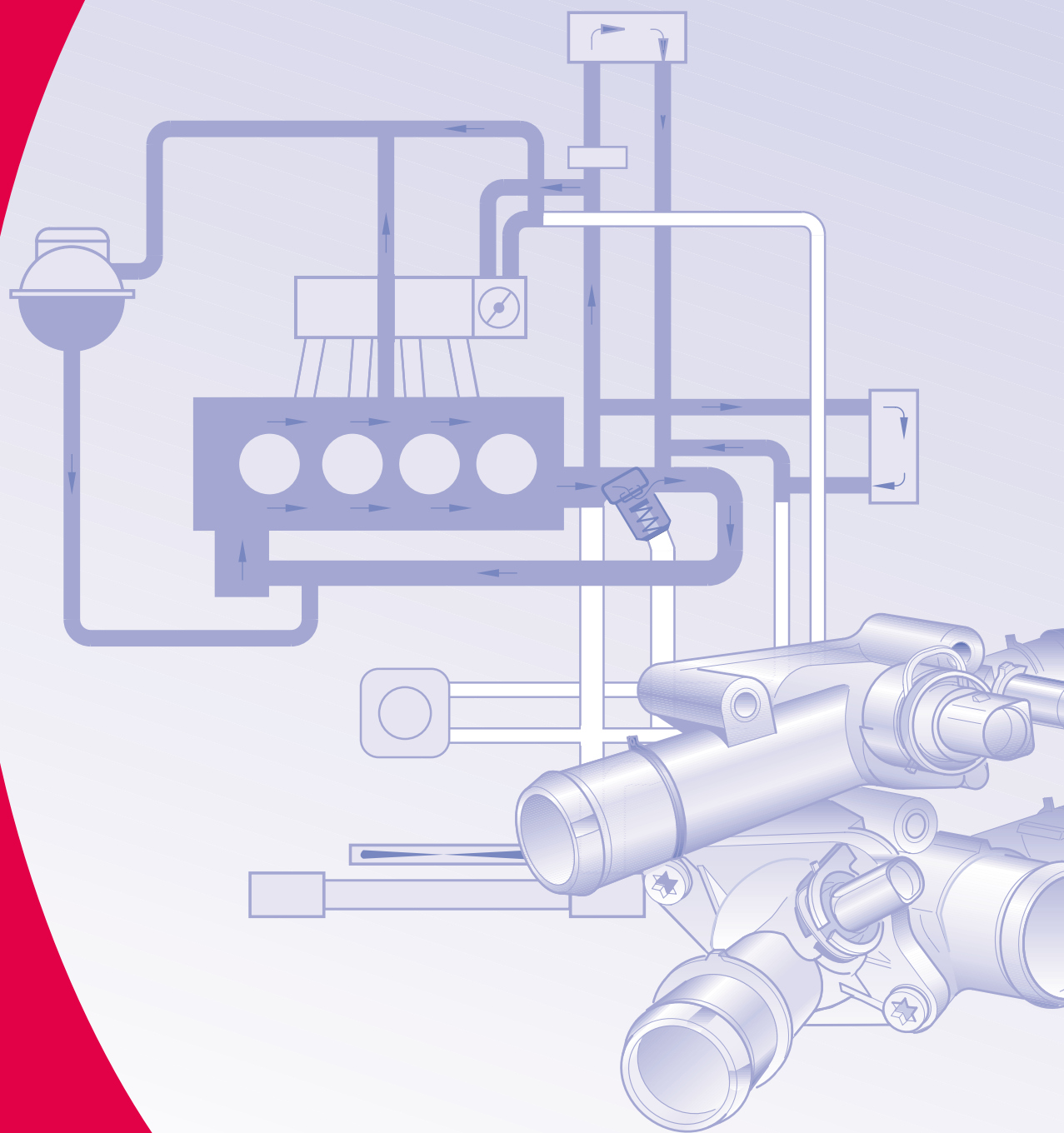

For internal use only © VOLKSWAGEN AG, Wolfsburg

All rights reserved. Technical specifications subject to change without notice.

940.2810.41.20 Technical status: 03/99

This paper is produced from
non-chlorine-bleached pulp.