

Self-Study Programme 214

Painting the Vehicle - Pre-Treatment

Basic Principles

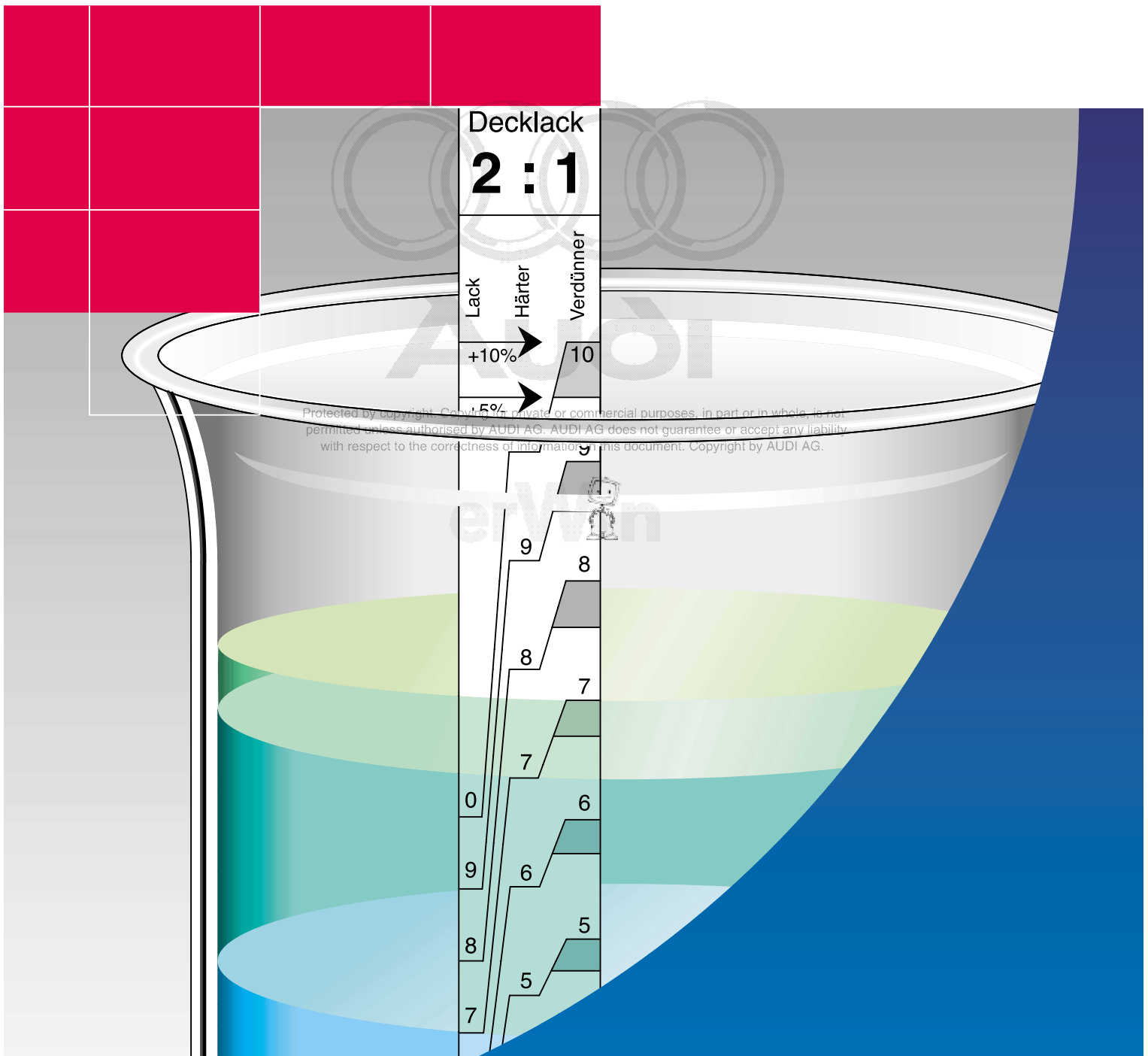

Protected by copyright. Copying for private or commercial purposes, in part or in whole, is not permitted unless authorised by AUDI AG. AUDI AG does not guarantee or accept any liability with respect to the correctness of information in this document. Copyright by AUDI AG.

Introduction

The topic of **vehicle painting** continues to gain importance in the field of providing customer service.

New technical processes and new materials - especially new paints - significantly increase the complexity of this specialist area.

The field of vehicle painting is no exception to the rule that only services based on fundamental knowledge can fully satisfy the demands of the customer.

Self-Study Programmes 214 and 215 were thus designed to provide an overview of the current state of the vehicle-painting art.

- SSP 214:
Painting the Vehicle - Pre-Treatment
- SSP 215
Painting the Vehicle - The Topcoat

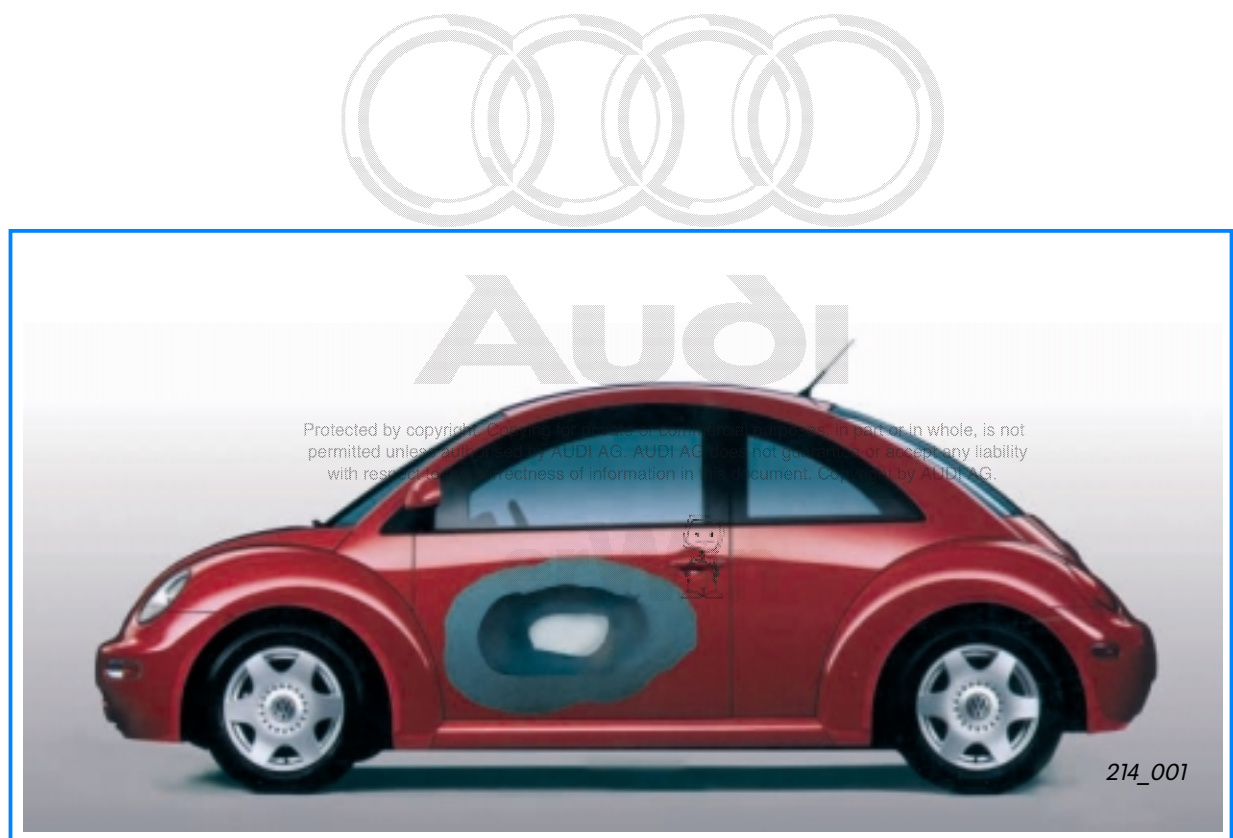

NEW



Caution Note

The self-study programme is not a workshop manual!

Testing, adjustment and repair instructions may be found in the appropriate service material.



Vehicle Painting – Basic Principles	4
Steel oxidation (corrosion)	4
Abrasive mediums	6
Prepartory materials and paint	12
The constituents of paint	15
The paint: classification by drying method	19
Painting in the Factory	22
Painting in the Repair Shop	28
Repair painting	28
Painting in the workshop	29
Pre-treatment of the surfaces to be painted	30
The protective primer	32
The filler	34
Sanding the filler	36
Application of the primer extender	38
Sanding the primer extender	42
Check Your Knowledge	44
Glossary	48



Protected by copyright. Copying for private or commercial purposes, in part or in whole, is not permitted unless authorised by AUDI AG. AUDI AG does not guarantee or accept any liability for the correctness of information in this document. Copyright by AUDI AG.

Vehicle Painting - Basic Principles



Steel oxidation (corrosion)

The vehicle body is constructed of steel, which is susceptible to oxidation (corrosion). The body is galvanised and painted to protect against the negative effects of oxidation.

Oxidation

Oxidation is a chemical process by which electrons are exchanged between two substances. The atoms which compose the oxidised substance release electrons. These electrons are then absorbed by the atoms which compose the oxidising substance. The opposite process is called reduction. A substance is reduced when it absorbs electrons.

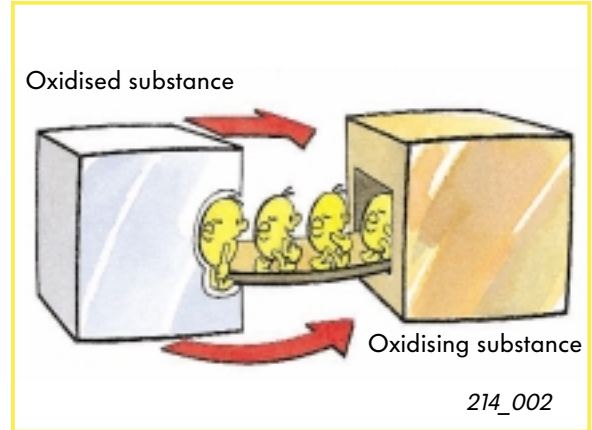

Oxidation

The tendency to release or absorb electrons varies among different substances.

Certain metals, such as iron, tend to release electrons. Iron is thus said to oxidise. Other metals, such as copper, have less of a tendency to release electrons and only oxidise when they are brought into contact with strongly reducing substances. Some metals, like gold, only oxidise under extreme conditions.

If two substances with varying oxidation tendencies are brought into contact, the result is a flow of electrons to the higher oxidation tendency.

- The substance which oxidises is called the **anode**.
- The substance which reduces is called the **cathode**.
- The mutual interaction is called a **voltaic cell**.

An example of a voltaic cell is a battery, which generates a flow of electrons from anode to cathode.

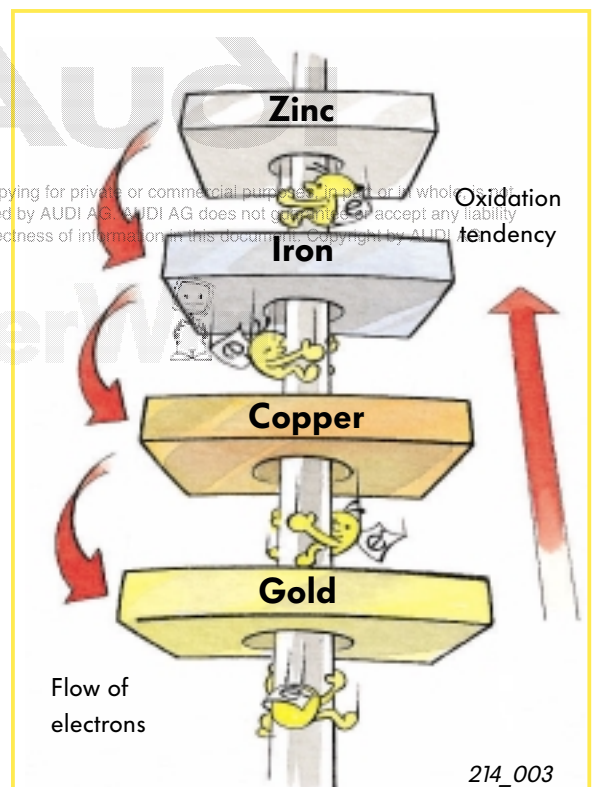

Oxidation tendencies

Corrosion protection

Vehicle bodies are constructed largely of steel panels, which have a tendency toward oxidation.

Various production measures are taken to ensure long-lasting corrosion protection.

These processes provide optimum protection which can be guaranteed for the service life of the vehicle.

Processes for protecting body panels against corrosion:

- Galvanisation
- Painting

Zinc is the most commonly used protective metal. Zinc possesses a greater oxidation tendency than steel. Galvanised steel will only begin to oxidise once the zinc has completely oxidised away.

Galvanised steel panels are thus very well protected against oxidation.

Combining the zinc coating with layers of paint results in optimum protection against corrosion. This form of protection is called the **duplex system**.

The protection against oxidation is a result of the zinc oxide, which is inseparable from the body panel. Oxidation occurs much more slowly with galvanised steel than with untreated steel. There, iron oxide forms and then breaks away from the base metal, continually exposing deeper layers of the steel. Zinc oxidises sooner than iron, but at a much slower pace.

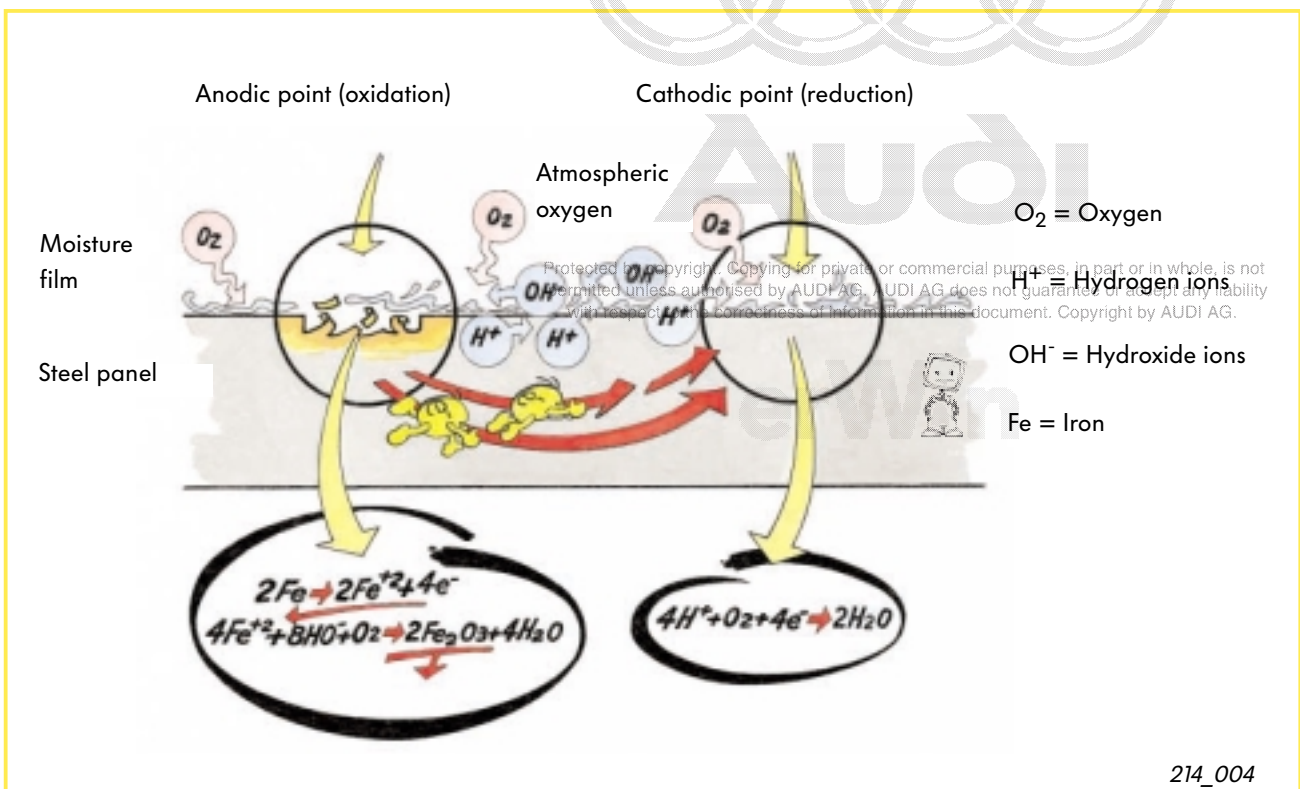

Vehicle Painting - Basic Principles



Abrasive mediums

Sanding a surface prepares it to receive a tightly bonding coat of paint.

Basic sanding principles

Sanding a surface removes excess **mechanical** material from it.

A hard material is guided with pressure across a surface, penetrating the surface layers and removing small pieces.

The minerals emery, corundum, and silicon carbide (carborundum) are commonly used sanding abrasives.

The materials to be sanded, such as extenders or fillers, contain soft constituents, such as barium oxide and lime, which facilitate the sanding process.

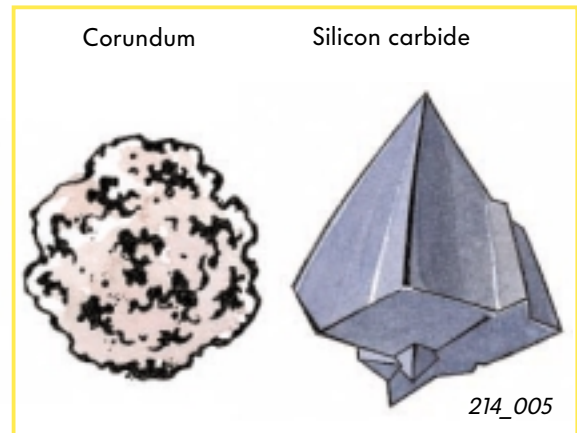

Corundum and silicon carbide

Hardness is a physical property.

One substance is said to be harder than another if it can penetrate it.

Various processes are available to determine hardness.

The most simple process was developed by the geologist Mohs.

It consists of a 10-stage scale which ranks minerals according to their hardness.

The first mineral in the scale is the softest and the last is the hardest.

The hardness of any other mineral is designated by the Mohs number of that mineral which can etch it.

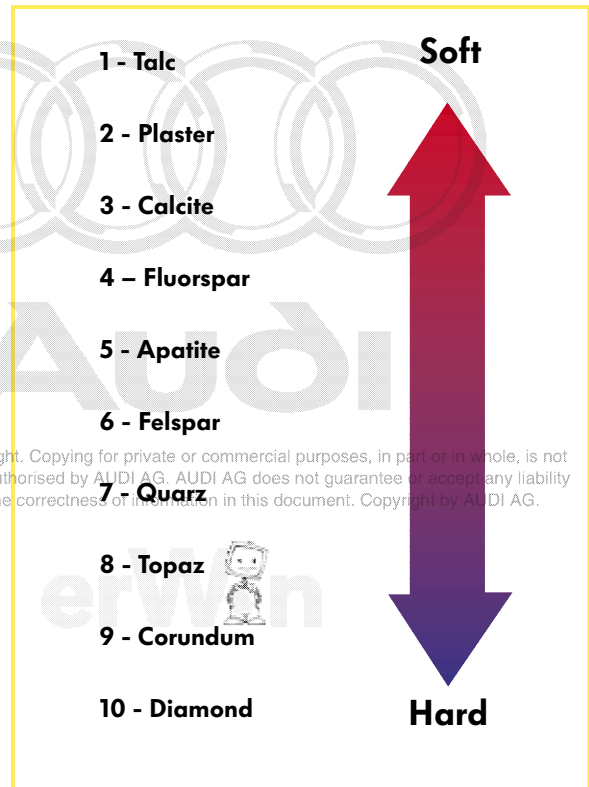

Mohs' hardness scale

Protected by copyright. Copying for private or commercial purposes, in part or in whole, is not permitted unless authorised by AUDI AG. AUDI AG does not guarantee or accept any liability with respect to the correctness of the information in this document. Copyright by AUDI AG.

Structure of abrasive mediums

The abrasive medium consists of an abrasive mineral bonded to a flat, flexible carrier material.

Carriers include:

- Paper
- Fabric
- Vulcanised fibre
- Plastic film

Hard, fragmented sanding minerals of varying coarseness are glued to the carrier.

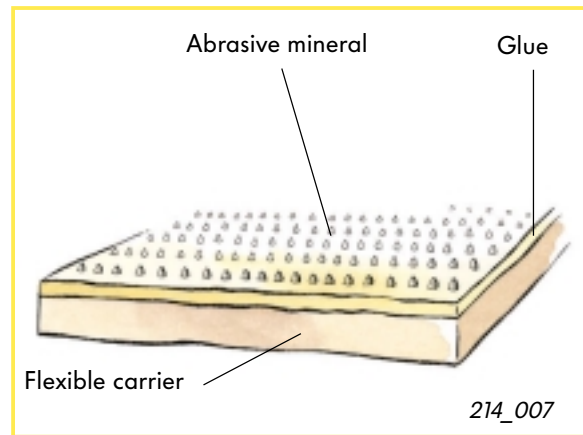

Structure of abrasive mediums

Abrasive minerals

Corundum and silicon carbide (carborund) are the most commonly used abrasive minerals.

- **Corundum** is a very hard mineral composed primarily of aluminium oxide. Very pure corundum is white in colour. When it contains additives, the colour may be anywhere from pink to brown. When used for sanding, corundum becomes dull and eventually wears away.
- **Silicon carbide** is harder than corundum but also more brittle. It is black with a blue shimmer. When silicon carbide is used for sanding, the mineral grains break off, resulting in new, oblong and pointed shapes.

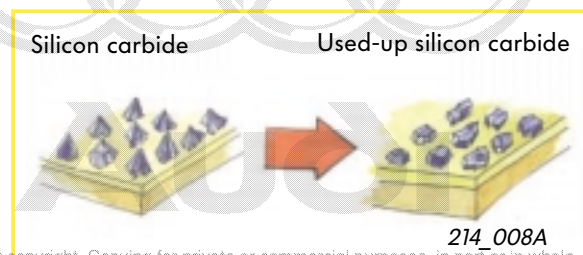
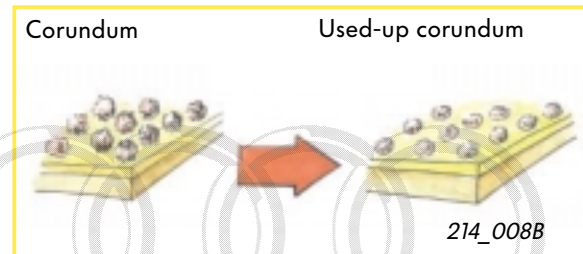

Protected by copyright. Copying for private or commercial purposes, in part or in whole, is not permitted unless expressly permitted by Audi AG. Audi AG does not warrant or accept any liability with respect to the correctness of information in this document. Copyright by AUDI AG.

Wearing away of the abrasive mediums



Vehicle Painting - Basic Principles



Coarseness of the abrasives

When abrasive mediums are produced, the sanding compounds are crushed and then sorted according to their particle size (coarseness).

The coarseness of the abrasive is categorised based on the average size of the individual grains.

The particle size is standardised according to the FEPA scale. FEPA is the European association of abrasive-medium manufacturers.

The particle size is designated by a **P** followed by a number.

P12 stands for the coarsest particle size, and P1200 for the finest.

The type of grain used for the abrasive is determined by the:

- Type of sanding job
- Hardness of material to be sanded
- Maximum sanding capacity
- Ambient conditions

An optimum result is only possible if the abrasive is properly suited to the sanding task at hand.

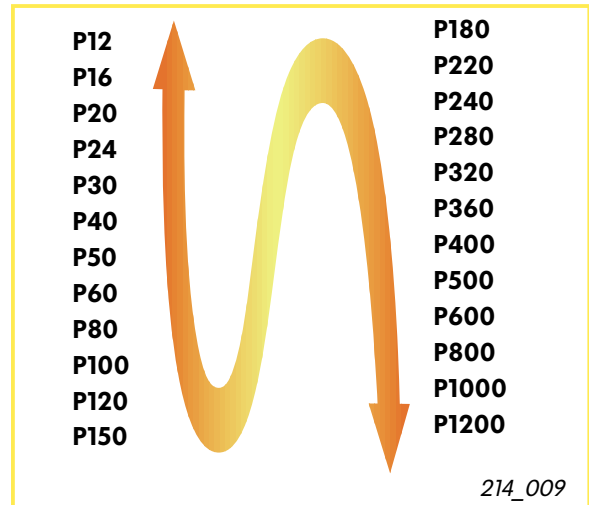

Complete FEPA scale

The carrier material

Flexible carrier materials are an integral part of the abrasive medium

The elasticity of the abrasive medium depends on the strength of the carrier material.

The thinner the paper or fabric carrier is, the more elastic the abrasive medium will be.

The primary factors in the selection of carrier type and weight are the surface to be processed and the hardness of the material to be sanded.



Flexible carrier material

214_010

The adhesive

Two types of adhesive are used for attaching the sanding minerals to the carrier:

- Organic adhesive
- Synthetic resins

The **organic adhesives**, such as rabbit skin, are made of natural products of both animal and vegetable origin.

They are sensitive to water.

This means: The abrasive is ruined when it comes in contact with water.

Phenol-, epoxy- und carbamide resin are all examples of **synthetic resins**.

They are heat treatable and heat resistant, enabling the production of abrasive mediums which are waterproof.

The sanding grain is glued to the carrier in two stages:

- First, a layer of glue attaches the individual abrasive grains to the surface of the carrier material.
- The second adhesive layer bonds the entire abrasive mineral to the carrier.

The same or different adhesives may be used for each step.

The combination is determined by the respective sanding procedure.

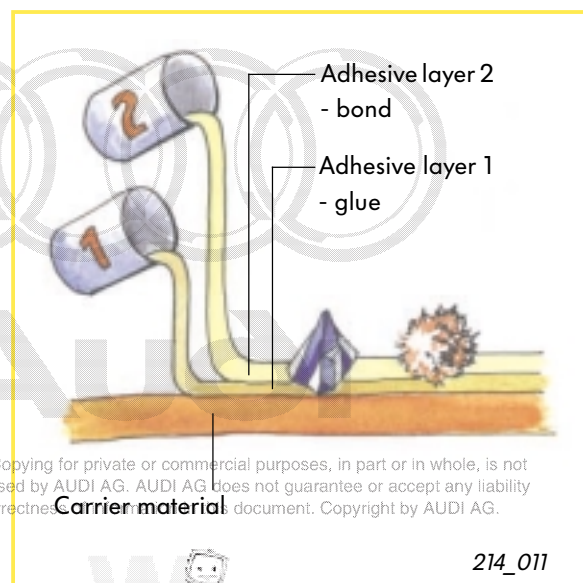

Adhesives and adhesive layers

214_011

Vehicle Painting - Basic Principles



Application of the abrasive mineral

The manner of applying the abrasive mineral is the decisive factor in the selection of the carrier material. The two types of application are:

- Gravity application
- Electrostatic application

Gravity application results in a random arrangement of the abrasive mineral on the carrier.

Electrostatic application aligns the abrasive mineral in a defined pattern. This alignment determines the properties of the abrasive medium.

The texture of the abrasive grain should always be determined by the surface to be treated.

The grain quantity per unit surface area is another important factor in determining the behaviour of the abrasive medium.

Closed grained structure: The abrasive minerals are packed tightly together.

Open grain structure: Spaces form between the abrasive particles. The sanding dust is carried away more easily and the abrasive medium does not become clogged.

Additives such as zinc stearate improve lubrication and removal of the abrasive residues.

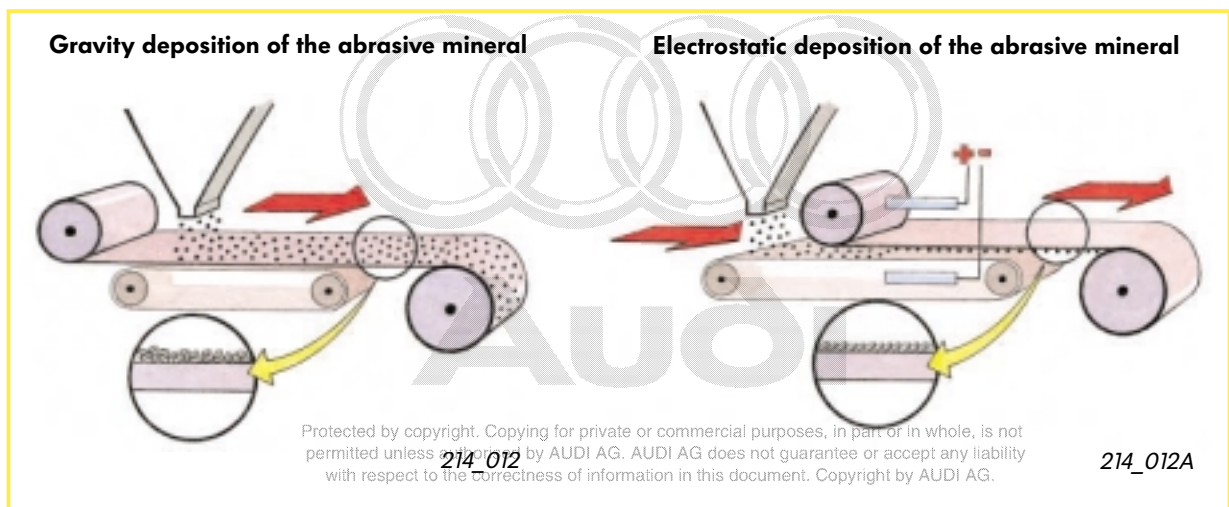

Gravity application and electrostatic application



Form of the abrasive medium

Large abrasive coils are rarely used directly. The abrasive medium obtains its application form via stamping processes. Various types of abrasive medium are available, depending on the final application:

- Sheet
- Disc
- Roll

The abrasive medium - in various sizes and shapes - may also be perforated for certain applications. The perforated holes assist in the extraction of sanding dust (when used with the appropriate sanding tool).

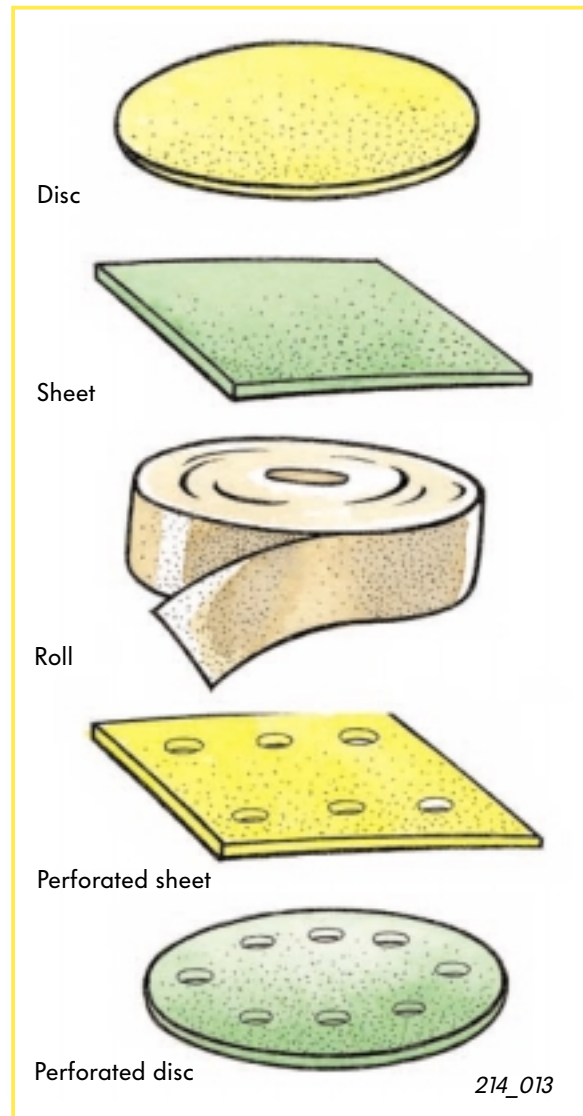

Formats of abrasive mediums



Summary:

To ensure optimum bonding of a subsequent coat of paint, the surface requires a certain level of roughness, which depends on the type of paint as well as the material to be coated. Non-adhesive surfaces, such as dry painted areas or factory coatings, must therefore be sanded to the proper degree of roughness.

Sanding the filler and extender assists in producing a smooth, even surface.

Protected by copyright. Copying for private or commercial purposes, in part or in whole, is not permitted unless authorized by AUDI AG. AUDI AG does not guarantee or accept any liability with respect to the correctness of information in this document. Copyright by AUDI AG.



Vehicle Painting – Basic Principles



Preparatory materials and paints

Paint coatings protect the underlying metal surfaces and thus lengthen the service life of the body parts. They also produce an attractive surface finish.

Definition

Paints are liquid substances of varying viscosity, which are applied to the surfaces by means of various procedures.

Once they completely harden, they form an even coat which is tightly bonded to the painted undercoat.

This layer is called the coating film.

The coating film serves two purposes:

- Protection of the surface against harsh external influences: humidity, solar rays, heat, road salt, chemicals, solvents, fuel, etc...
- Aesthetic treatment of the surface to compensate for irregularities in colour, and to provide lustre and various optical and colour effects.

“Technical” refers to paint’s protective functions, and “aesthetic” to its optical functions.





Terminology

Various types of products fall under the heading “Preparatory materials and paints”.

The products used in painting the vehicle are listed below.

Filler

Filler is a plastic composite material which comes in a paste form.

It is applied with a spatula or similar tool.

Filler compensates for the irregularities in the surface and seals cracks in the material.

It must bond very well to the widest variety of undercoats and also be easy to sand.

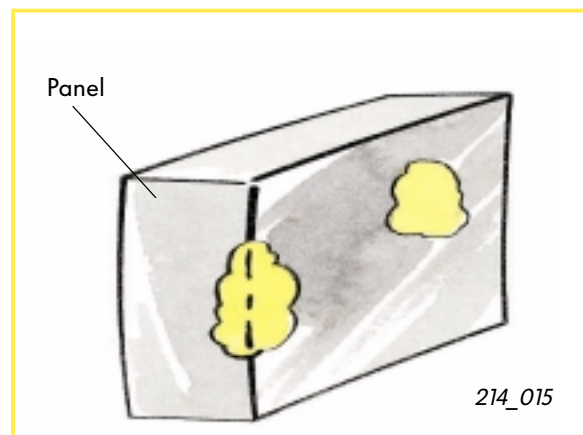

Filler

Primer

Primers are fluid mixtures that may be pigmented.

They are applied for the following reasons:

- Undercoat for sealing pores
- Corrosion protection
- Bonding layer for the topcoat

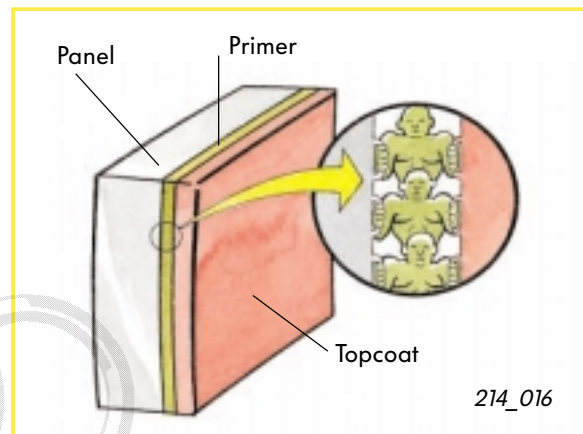

Primer

Extender

Extenders are pigmented, fluid mixtures rich in solid particles.

They smooth out the irregularities in the primer (filling).

Extenders produce a smooth, even surface to which the topcoat will be applied.

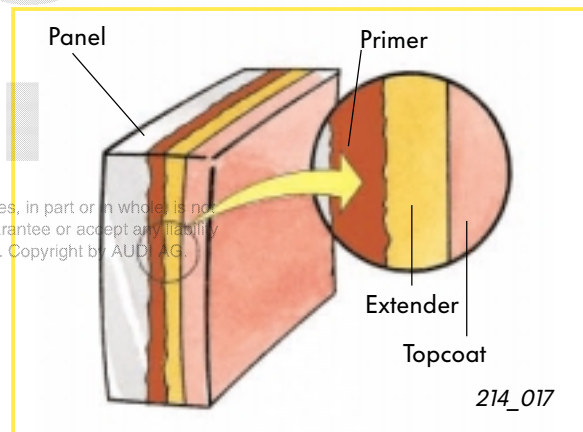

Extender

Vehicle Painting – Basic Principles



Enamel paint

A type of paint which yields an especially smooth and hard coating film.

Paint colour

Essentially, paint consists of organic pigments which are soluble in a bonding agent, the base or the organic medium. Paint colours are distinguished by their intensity. They can be more or less translucent or transparent.

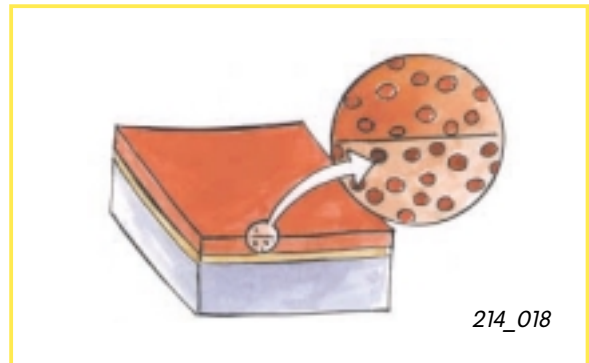

Paint colour

Clear lacquer

Clear lacquer is a liquid, pigmentless compound which can be applied in a thin layer on the surface. After drying, the clear lacquer forms a transparent coating.

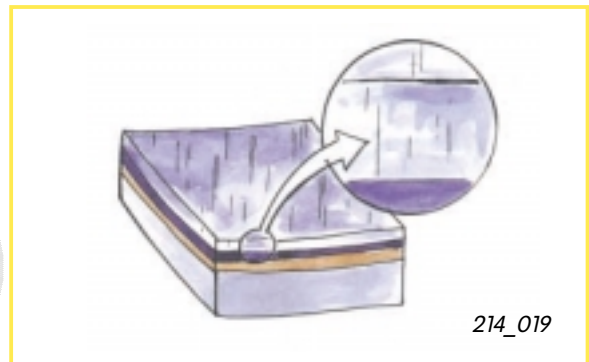

Clear lacquer

Colourants

Protected by copyright. Copying for private or commercial purposes, in part or in whole, is not permitted without the prior written consent of Audi AG. Audi AG does not accept any liability with respect to the correctness of information in this document. Copyright by AUDI AG.

Colourants are materials which, once applied to a surface, penetrate it and change its colour.

They are normally transparent and do not form a surface film.

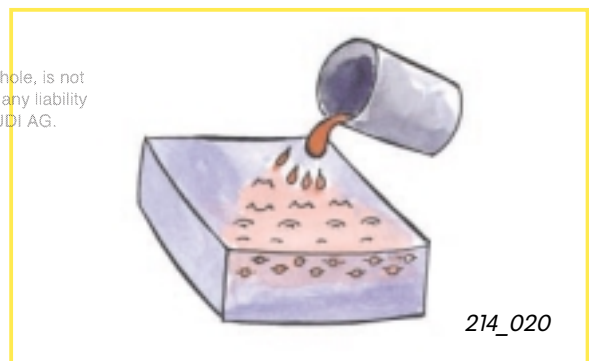

Colourants

The constituents of paint

The following ingredients enable paint to fulfil its protective and optical functions:

- Bonding agent
- Pigments
- Solvents
- Additives

The bonding agent

The bonding agent is that fraction which is neither volatile nor solid after the paint dries. The bonding agent may also be called a resin.

As the carrier substance for other components of the paint, the bonding agent fulfils the most important role.

The chemical composition of the bonding agent determines the properties of the paint, such as:

- Method of drying
- Properties of the topcoat, such as its hardness or lustre
- Weather resistance
- Elasticity
- Adhesion

A paint is designated by the bonding agent upon which it is based.

Acrylic paint contains acrylic as a bonding agent and cellulose paint contains cellulose-based bonding agents.

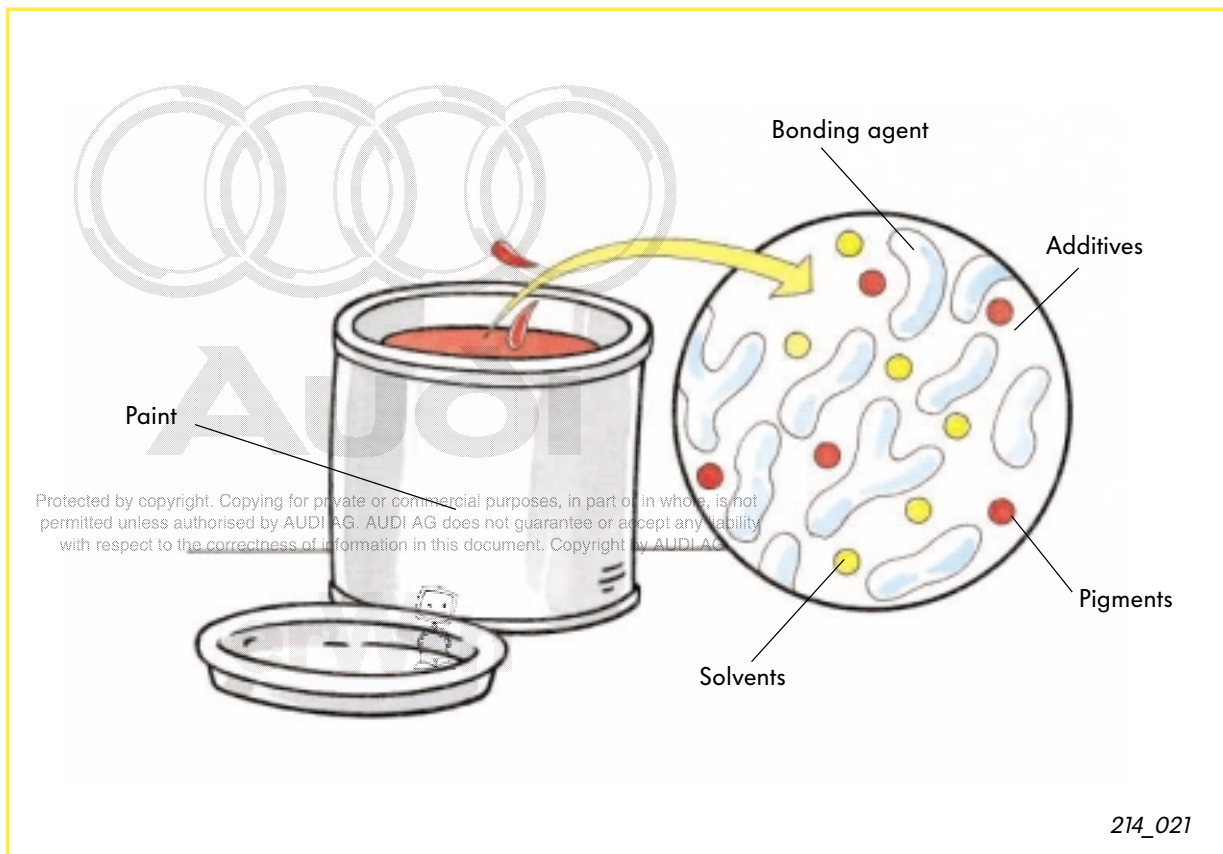

Vehicle Painting – Basic Principles



Pigments

Pigments are solid, very fine particles which are not soluble in the bonding agent.

They are manufactured by pulverising organic and inorganic materials.

Pigments mainly endow the paint with the following properties:

- Colour
- Opacity

Other pigments, with completely different functions, may also be added to paint formulae.

Pigments are classified in the following groups:

- **Corrosion-protection pigments**

They protect the base or carrier material (e.g. steel, aluminium, copper) from corrosion.

- **Finish pigments**

These are opaque particles with a defined fast colour (e.g. red, green, blue pigments). They are used to add colour.

Through their composition, these pigments can yield colour or optical effects.

For example, aluminium and mica pigments yield metallic and pearl effects, respectively.

- **Filler pigments**

These pigments do not intrinsically have very strong covering power.

They complement the finish pigments and give the paint more “body”.

- **Pigments with special functions**

They give the paint certain properties, such as anti-encrustation (boat paint), fungicide (paint for damp areas) and flame retardance.

Filler pigments



Waterproofing pigments



Opaque finish pigments



Flame-retardant pigments



214_022

A few pigments and their properties

Solvents

Solvents are added to the paint to keep the bonding agent liquid. The purpose is to prevent coagulation until the moment of application. After it has been applied, the solvent evaporates as part of the drying process. Solvents do not remain present in the coating film which bonds permanently to the base material. Technically, solvents are referred to as “volatile bonding agents”.

If a paint requires a greater degree of liquidity, it may be thinned. Additional “volatile bonding agent” (thinner) is then added to the paint. Solvents and thinners may have the same or different chemical composition.

The solvent and the thinner must have a chemical composition compatible with that of the bonding agent.

A distinction is made between two groups of paint:

- **Solvent-based paints**

Solvents and thinners consisting of volatile organic compounds, such as acetone, petrol and butyl acetate.

- **Water-based paints**

Paints in which water forms the main constituent of the solvent and thinner.

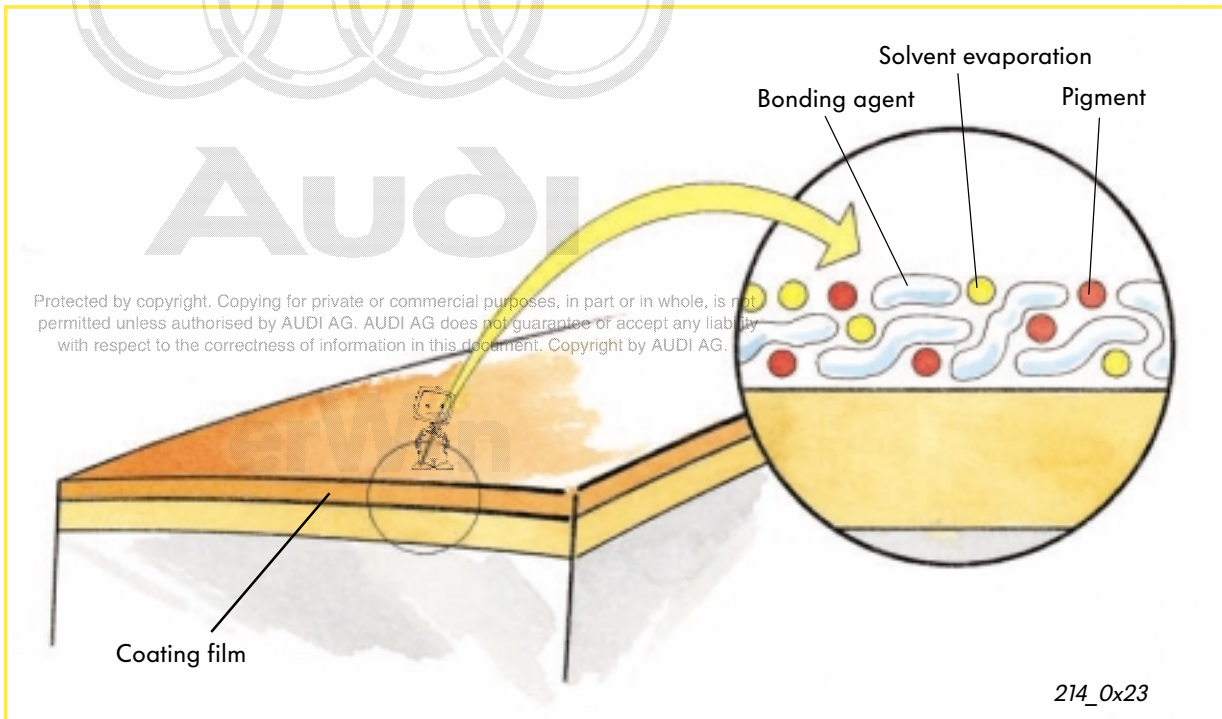

Solvent

Vehicle Painting – Basic Principles



Additives

The overall quality of the paint is determined by the quality of the main components, the mixture ratio and the careful selection of additives. Without additives, the durability of the paint is restricted, or its properties do not turn out as desired.

Types of additives:

- **Hardeners (drying accelerators)**
Influence the hardness and curing of the paint.
- **Extenders**
Influence the features of the surface structure, such as roughness and filling.
- **Softeners (elastifiers)**
Influence the elasticity and flexibility of the paint.
- **Thickeners**
Improve the consistency of the paint and prevent runs (thixotropy).
- **Wetting agents**
Improve the homogenisation of the other constituents.
- **Dispersion agents**
Prevent lump formation during storage.
- **Anti-sedimentation agents (No depositon)**
Keep the pigments held in suspension.
- **Emulsifiers**
Improve the mixing of the ingredients.

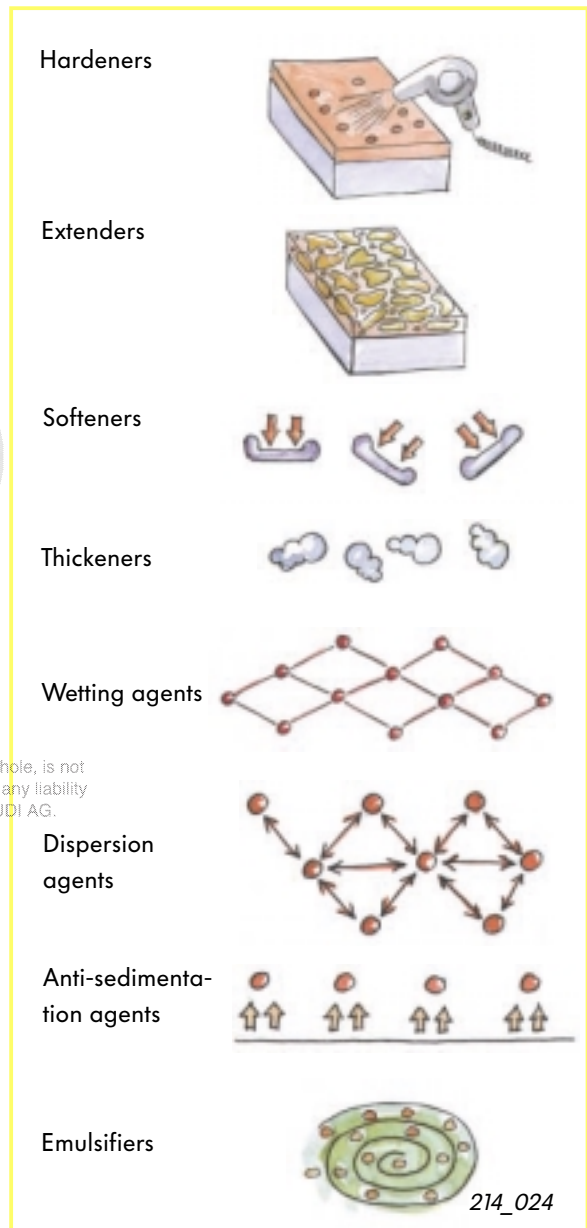

Additives

214_024

The paint: classification by drying method

The way that the paint dries determines many of the properties of the final coating film.

Drying

After the bonding agent, paint may be classified according to various other criteria. The most important criterion is the manner in which the paint dries and hardens.

Depending on the paint, a distinction is made between **three** methods of drying:

1C synthetic resin paint

- Drying by evaporation of the solvent.
- Drying by oxidation of the bonding agent.

2C paint

- Drying by a chemical reaction between two or more constituents.

Drying by evaporation of the solvent.

This is the simplest method of drying. The bonding agent solidifies as the solvent evaporates. Heat accelerates the process of evaporation.



Paint dissolves as it comes into contact with the solvent (refers to 1C synthetic resin paint).

Protected by copyright. Copying for private or commercial purposes, in part or in whole, is not permitted unless authorised by AUDI AG. AUDI AG does not guarantee or accept any liability with respect to the correctness of information in this document. Copyright by AUDI AG.

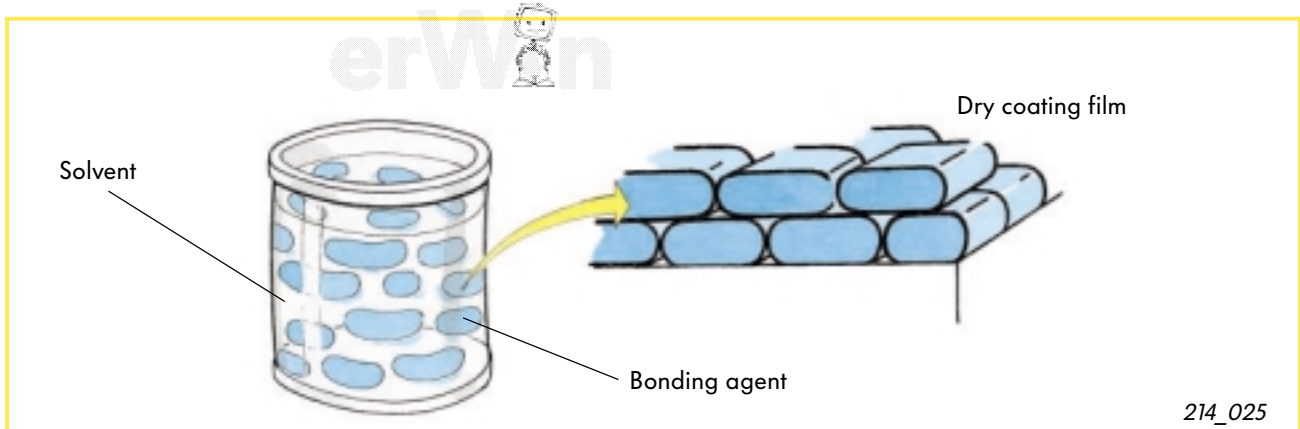

214_025

Drying by evaporation of the solvent



Vehicle Painting - Basic Principles



Drying by oxidation of the bonding agent.

Evaporation of the solvent occurs in all methods of drying.

With drying by oxidation, a reaction with atmospheric oxygen occurs in addition to a chemical transformation of the bonding agent. The drying process can be accelerated by the addition of a hardening agent.

The chemical properties of dried paint are different from those of the original bonding agent.

The properties of the coating film are thus not affected by the solvents contained in the paint.

The drying process may be accelerated by the application of heat, which effects a faster evaporation of the volatile components.

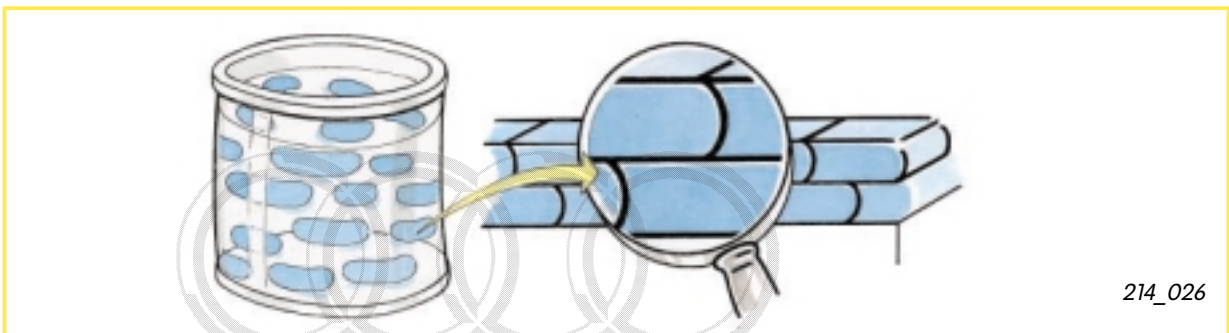

Drying by oxidation of the bonding agent

Drying by chemical reaction between two or more constituents.

The coating film is the result of a chemical reaction or by the chemical bonding (polymerisation) of components.

If a reaction occurs at the ambient temperature, the components must be mixed immediately before use.

If the reaction does not take place until a higher paint temperature is reached, pre-mixed components may be used.

These paints are known as **thermo-hardening**.

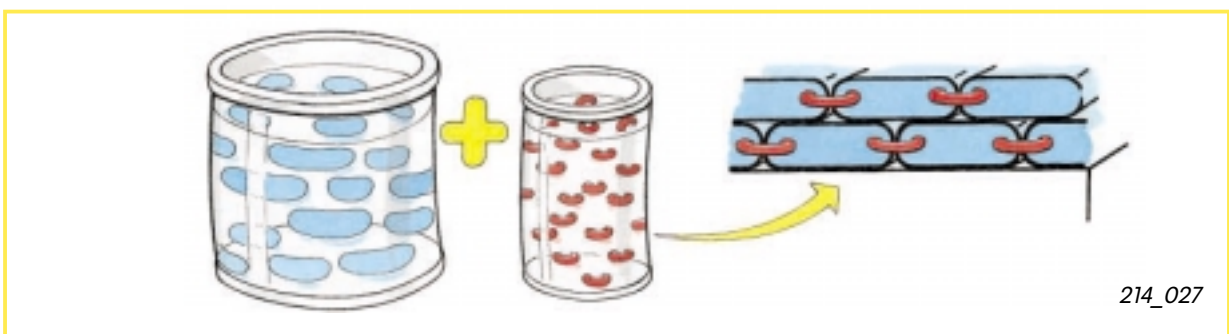

Drying by chemical reaction between two or more components

If two components must be mixed before application, then the paint is known as a two-component paint (2C paint).

The components are:

- Resin
- Hardener (also catalyst or activator)

The components are kept in separate containers, each with corresponding solvents.

They are mixed at a specific ratio immediately before application. The mixing takes place in cylindrical containers with the aid of measuring and mixing sticks.

Heat accelerates the drying of the 2C paint. The chemical properties of the resulting coating film are different from those of the original constituents.

2C paint is distinguished by its high resistance to chemical and physical resistance influences.

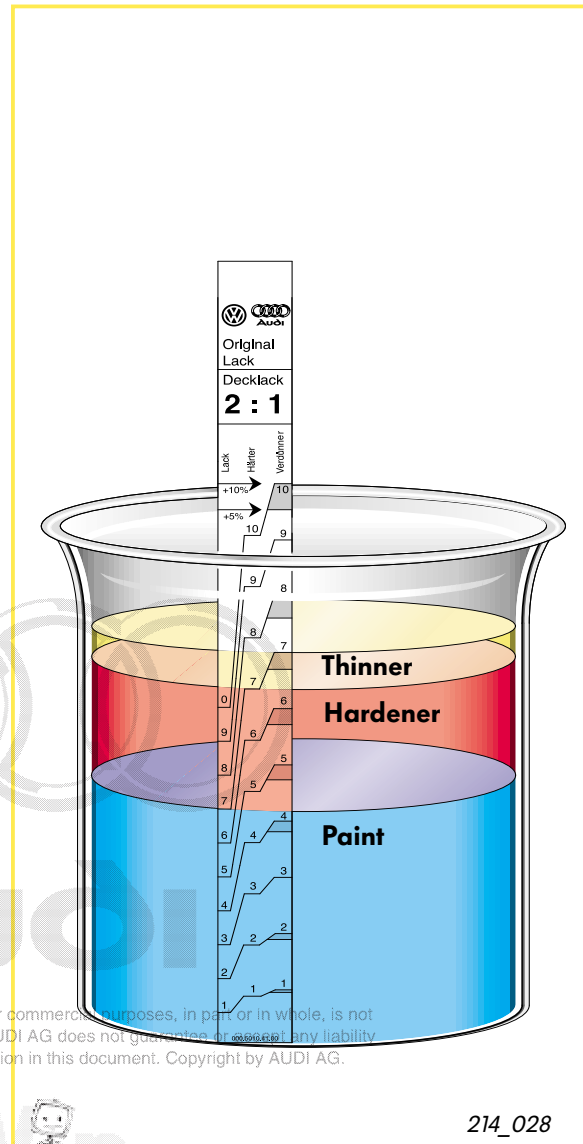

Measuring and mixing stick



Painting in the Factory

Painting the series bodies

In the factory, vehicle bodies are painted in an optimally co-ordinated production-line sequence.

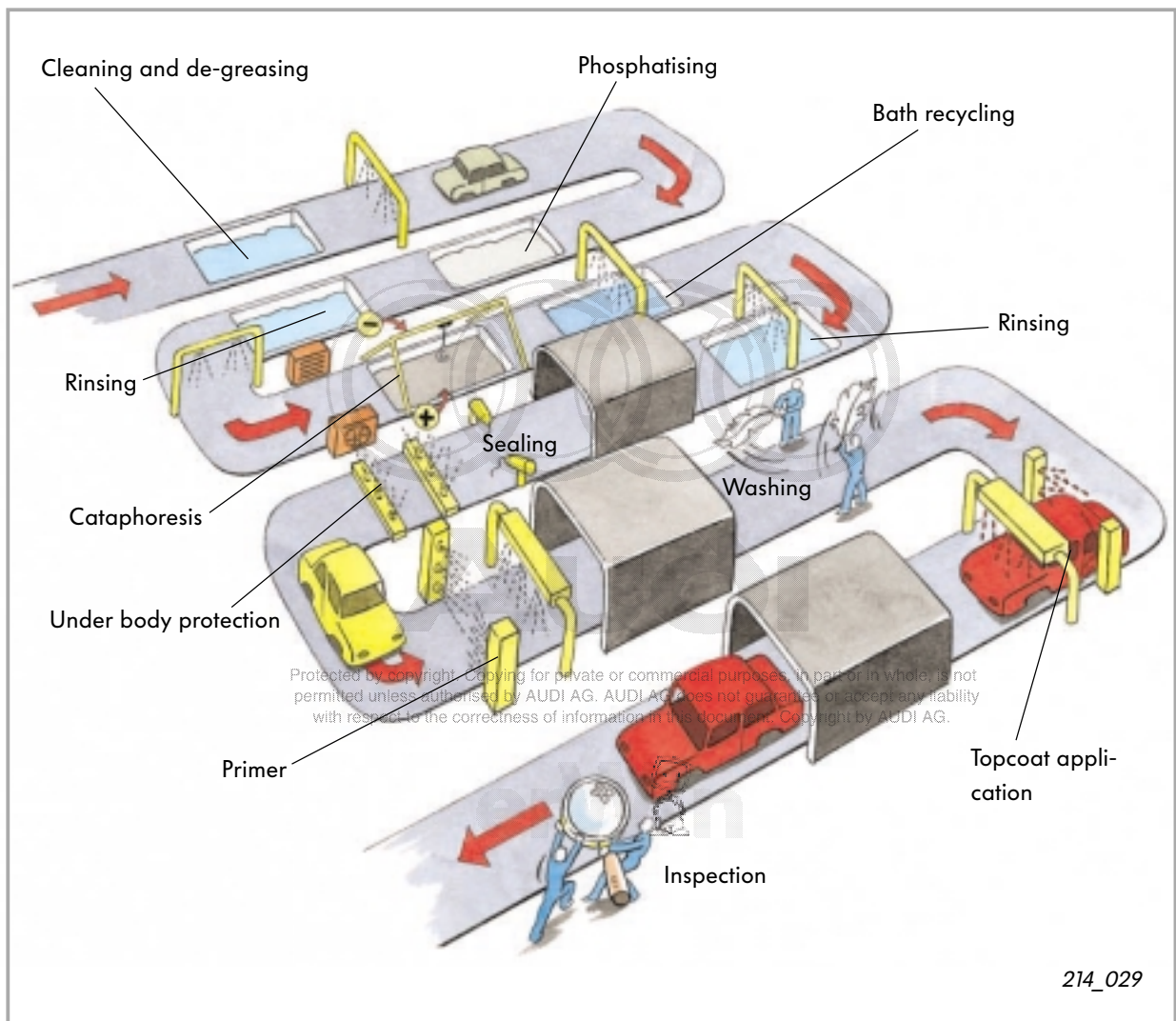

Sequence of vehicle-body painting in the factory

Pre-galvanised panels

Pre-galvanised panel is zinc-coated steel plate. The zinc coating protects the metal against corrosion. Superficial damage to the coating film, which exposes areas of bare metal, will result in oxidation of the zinc.

The steel is thus protected by the so-called "sacrificial zinc effect".

The coating of the steel plate with zinc is performed either electrolytically or by immersion in molten zinc.

It may be coated on one or both sides. The thickness of the zinc layer is between 5 - 10 µm, depending on the area of application.

Hot galvanisation can always be recognised by its surface structure (zinc blooms).

Exterior panels to be painted are electrolytically galvanised.

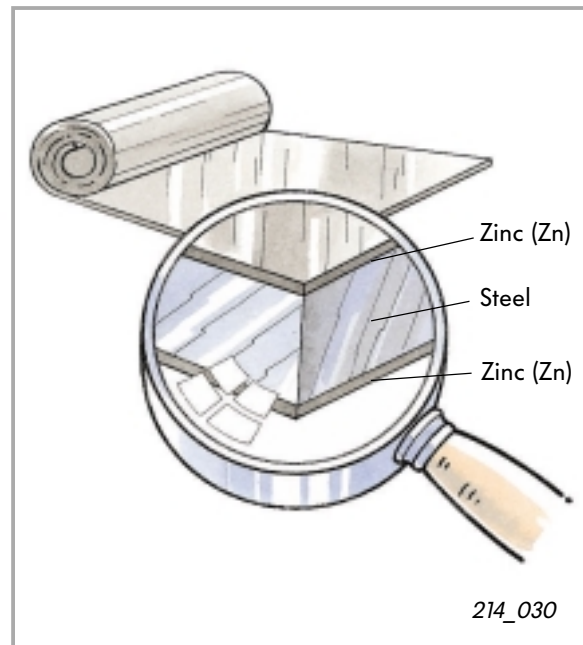

Double-sided galvanised steel panel



Pre-treatment of panels: cleaning and de-greasing

The first step in the series painting process is the cleaning and de-greasing of the unpainted body.

The body is submerged in a cleaning bath and then sprayed with de-greasing solutions.

After rinsing and drying, all fatty residues are removed from the bodywork.

Phosphatising

Phosphatising is a process in which the body is submerged in a bath containing various phosphate salt solutions.

The result is the formation of a crystalline metal phosphate on the body panel. This means: optimum adhesion base and corrosion protection.

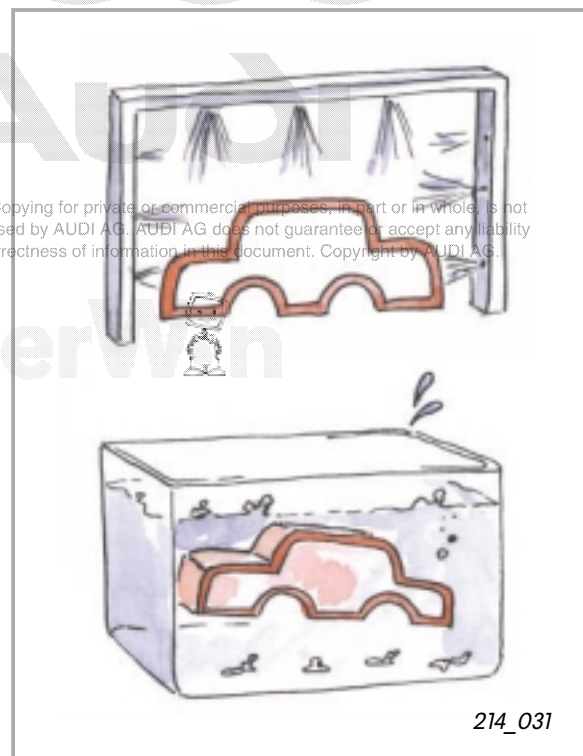

Cleaning and de-greasing

Painting in the Factory

Priming by cataphoretic dipping

After phosphatising, the bodywork is cataphoretically dipped, which provides excellent protection against oxidation.

Cataphoresis (= migration of positively charged particles in a liquid) is an electrical process which is also called electrophoresis (= transport of electrically charged particles by electrical current).

The body is completely dipped in a bath of paint-electrolyte solution.

It is then connected to the negative pole of a direct-current source. The positive pole forms a series of anodes arranged around the basin.

The field forces deposit the positively charged paint particles onto the negatively charged body panelling.

Advantages:

- Coating of all external surfaces, internal surfaces and hollow spaces.
- Even coating thickness.

Cataphoretic dipping can deposit a layer of primer up to 20 µm thick onto the body.

In the subsequent rinsing zone, non-adhesive paint residues are removed.

The last rinsing cycle is then performed using completely desalinated water.

The body - now free of water droplets - is placed in the dryer. There the primer hardens at 180 °C.

The factory-supplied spare parts are also primed by the cataphoretic-dipping process.

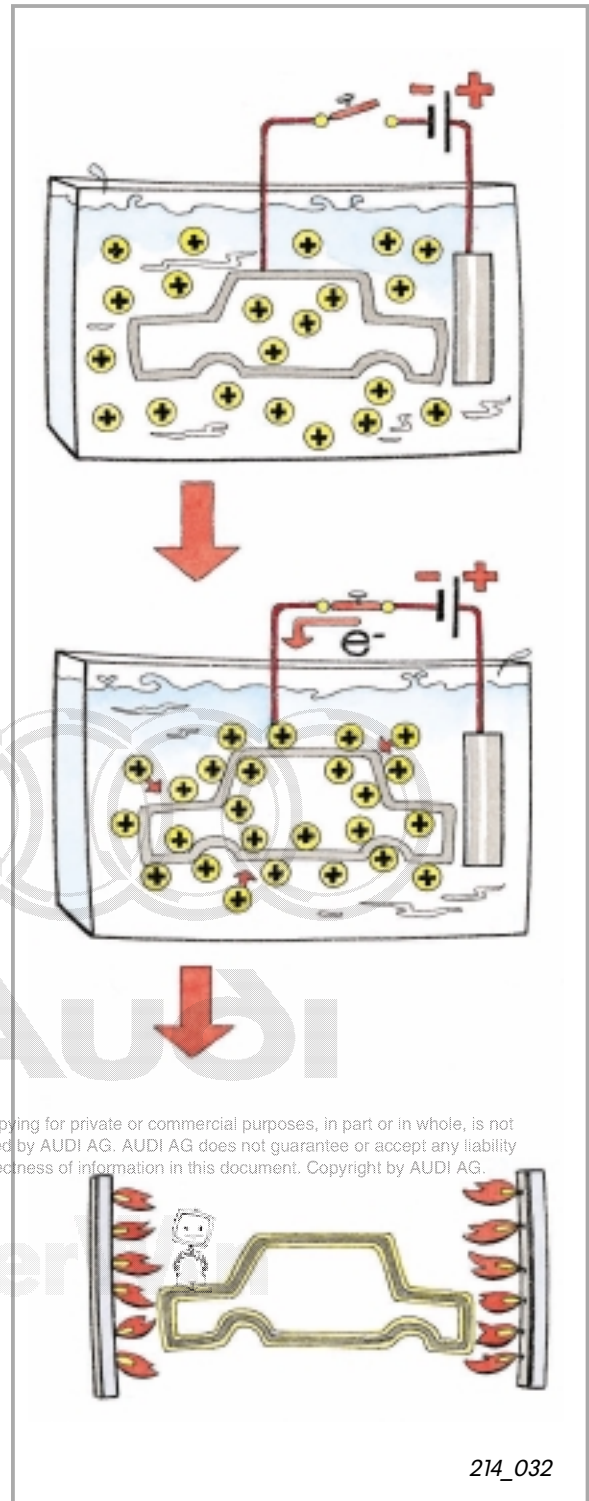

Priming by cataphoretic dipping

214_032

Sealant and fine sealing

Metal sheet overlappings, metal edges, grooves, butt joints and weld seams are bonded with sealant.

The sealant compound is a highly viscous polyurethane material.

The sealant is sprayed on the aforementioned, highly corrosion-susceptible areas.

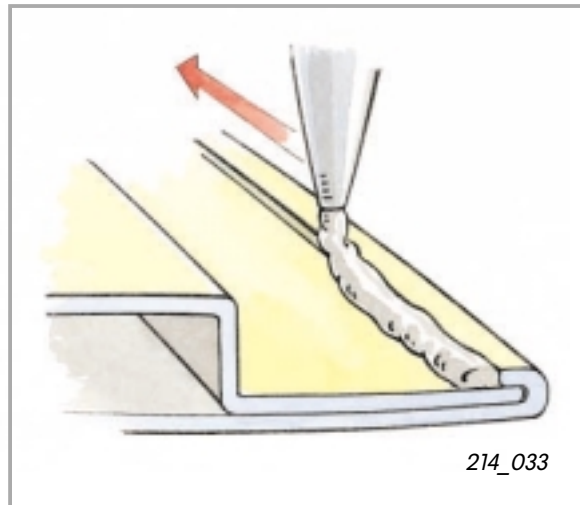

Application of the sealant

Protection against stone impact

Areas susceptible to stone strikes are protected by means of a stone impact protection base.

A stone impact protective base is a highly viscous, elastic paint.

The chassis pan and the wheel housings are normally coated with a protective stone impact base.

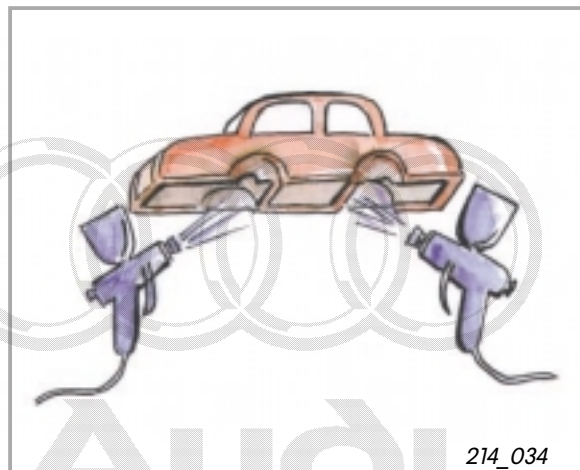

Stone impact protection base

Primer

The next coat on the body is the primer. Its function is to smooth out any surface blemishes and to provide a uniform surface for the topcoat.

Special jets spray the electrostatically charged paint particles onto the likewise electrostatically charged body.

The advantage of this procedure is the economical use of material.

The primer is dried at 170 °C. After hardening and cooling at room temperature, all areas which need to be evened out may be sanded. The body is then cleaned of all residues.

Protected by copyright. Copying for private or commercial purposes, in part or in whole, is not permitted unless authorised by AUDI AG. AUDI AG does not guarantee or accept any liability with respect to the correctness of information in this document. Copyright by AUDI AG.



Painting in the Factory

Topcoat

The last coat of paint is the topcoat. It provides:

- Colour
- Lustre
- Special effects
- Hardness

The topcoat is applied in a one-coat or two-coat process.

With two-coat processes, first the base paint is applied and then a clear lacquer.

The two-coat topcoat - with its colours and effects (uniform, metallic, pearl effect) - combines with the clear lacquer to form a hard, shiny film.

With single coating, the paint itself acts as the protective layer; with two-coating, the clear lacquer serves this purpose.

The application of the topcoat is carried out similarly to the application of the primer in the electrostatic coating procedure. This process offers advantages over the usual spray-gun application.



Metallic paint is applied in the factory using an automated spray gun.

Electrostatic application results in the specific alignment of the aluminium particles. This alignment cannot be reproduced in the repairshop using conventional techniques.

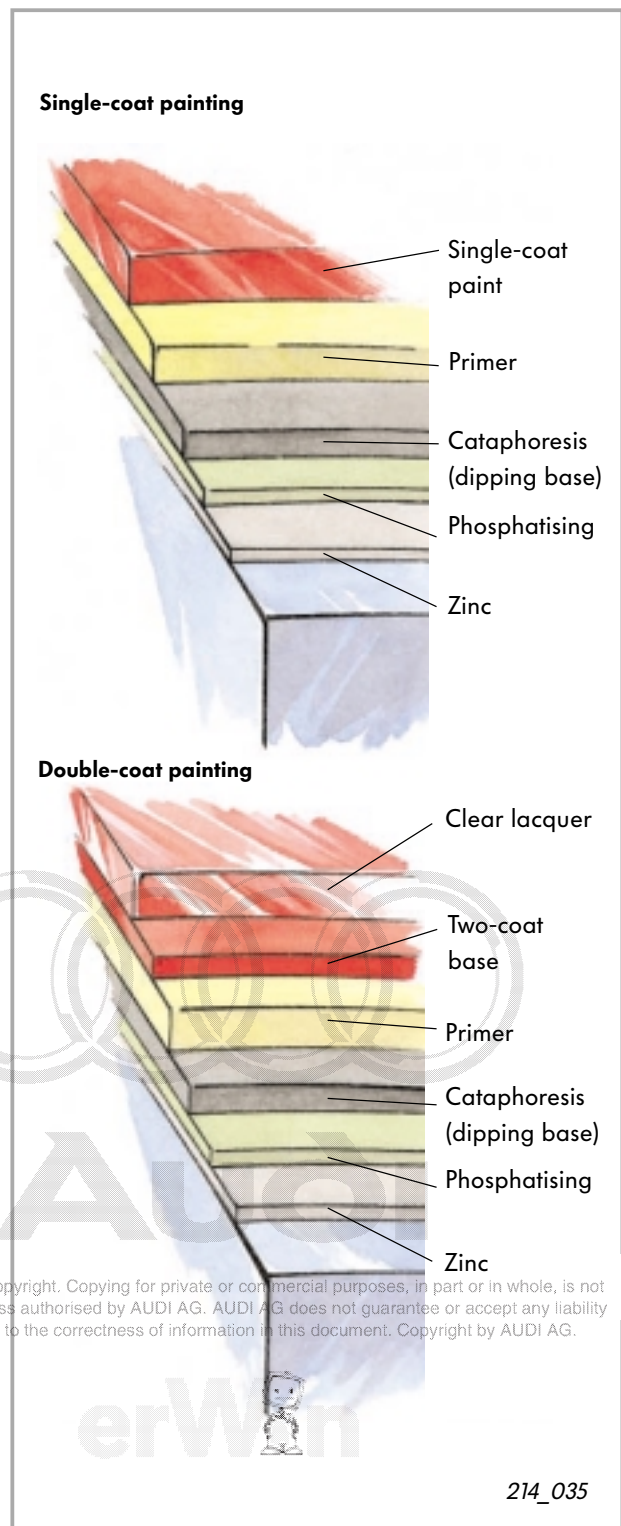

One-coat and two-coat paints

Wax and corrosion-protection agents

Sealing the cavities with liquid wax concludes the painting process.

This seal provides the cavities with effective, long-term protection against corrosion.

In addition to the wax treatment, polyurethane foam may be used in specially defined cavities to improve the acoustics and reduce disagreeable external odours.

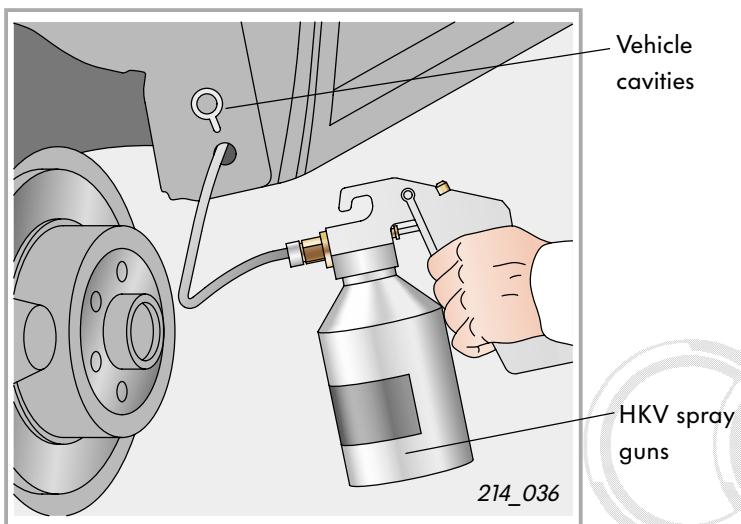

Cavity-conservation gun



Audi

Protected by copyright. Copying for private or commercial purposes, in part or in whole, is not permitted unless authorised by AUDI AG. AUDI AG does not guarantee or accept any liability with respect to the correctness of information in this document. Copyright by AUDI AG.



Painting in the Repair Shop

Repair painting

A big difference exists between painting in the factory and painting in the workshop.

In production, the body is painted by itself, without the engine, interior panels, upholstery etc.

In repair, these parts are not removed (except in the case of body replacement).

All parts not to be painted must therefore be covered.

Painting in production always has a constant structure. Effect painting yields a constant arrangement of the aluminium or mica pigments. Repair painting always displays the signature of the tradesmen, in both its structure and appearance.

The paint used in a workshop must dry at lower temperatures, because plastics, sub-assemblies and the vehicle electronics **cannot** be exposed to temperatures over 60 - 70 °C.

In order to carry out such work, the correct equipment, aids and tools must be available. For more detailed information, refer to Self-Study Programme 215, "Painting the Vehicle - The Topcoat".



Repair painting

Painting in the workshop

The workshop painting process consists of two phases:

- Pre-treatment for corrosion protection and to compensate for surface irregularities.
- Application of the topcoat to restore the original appearance.

If a vehicle is brought into a shop with body damage, the sheet-metal parts will either be restored or replaced.

The repair paint job protects the damaged parts against corrosion, smoothes out irregularities in restored parts and re-creates the original appearance.

Pre-treatment

The preparatory materials prepare the base for the application of the topcoat.

In no event may the topcoat be directly applied to the metal section.

The following preparatory materials are used for the repair paint job:

- Filler
- Primer
- Extender

The topcoat is applied to the primer, the extender or existing coats of paint.

These must first be sanded using the abrasive medium suitable for the topcoat.

Topcoat

The topcoat forms the outermost protective layer of the paint.



Information on the application of the topcoat may be found in the 'Basic principles' chapter.

Self-Study Programme 215, "Painting the Vehicle - The Topcoat" provides instructions for the correct application of the topcoat.

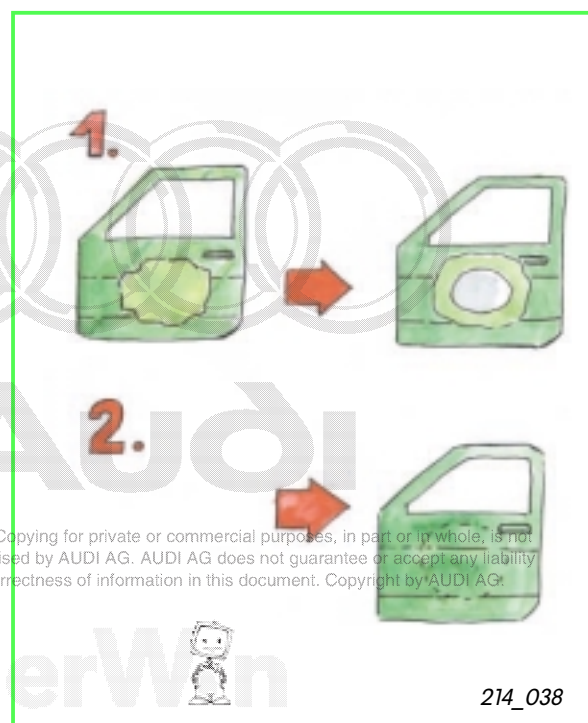

Protected by copyright. Copying for private or commercial purposes, in part or in whole, is not permitted unless authorised by AUDI AG. AUDI AG does not guarantee or accept any liability with respect to the correctness of information in this document. Copyright by AUDI AG.

Painting in the Repair Shop

Pre-treatment of the surfaces to be painted

The base material must be pre-treated according to instructions to ensure that the paint bonds perfectly.

Cleaning, removal of corrosion and sanding are the key phases of the pre-treatment.

Cleaning the vehicle

If a vehicle is brought into the workshop to be painted, all the surfaces must be thoroughly cleaned.

The vehicle must be washed before the start of servicing.

Silicone cleaner and a dust cloth are used to give the parts to be painted a final cleaning.



214_039A

Cleaning the vehicle



Removal of corrosion

If protective layers are removed during body restoration, the exposed areas will be susceptible to corrosion.

This is especially true if the paint is not applied immediately after the body is restored.

If any corrosive areas are already present on the vehicle, they must be sanded away.

The abrasive medium must be applied to the surface in such a way that the corroded area is completely removed without any unnecessary reduction of sheet metal strength.

After sanding, there may still be some invisible areas of corrosion.

Passivation (= treatment using acid zinc phosphates or similar corrosion protective primers) creates a protective film and prevents further corrosion.

Passivation materials may only be applied to bare or galvanised steel panels.

This treatment is not suitable for aluminium or other materials.

The protective primer must be applied within 20 minutes after the passivation agents are applied, or the desired effect will be lost (a counter-reaction may even take place).

Copying for private or commercial purposes, in part or in whole, is not permitted unless authorised by AUDI AG. AUDI AG does not guarantee or accept any liability with respect to the correctness of information in this document. Copyright by AUDI AG.



De-greasing surfaces

To ensure that the paint bonds optimally, the respective surfaces must be blow-dried with compressed air and then de-greased.

A de-greasing solvent (silicone cleaner) is applied over small areas. Before the solvent evaporates, the treated area must be rubbed with a clean, dry cloth.

The solvent used (silicone cleaner) must loosen impurities but may not react with the base.

To optimise the de-greasing result, let the solvent evaporate slowly while rubbing it off.

Simply allowing the solvent to dry has no cleaning effect; it instead results in the deposition of impurities.

De-greasing, besides being important **before the paint application**, is also **important before sanding**, for two reasons:

- Sanding a greasy surface can result in lumps formed by greasy sanding dust. Sanding tracks will be left on the surface, and the abrasive will soon become unusable.
- The abrasive grains force the fat and oil inwards, making them difficult to remove later.

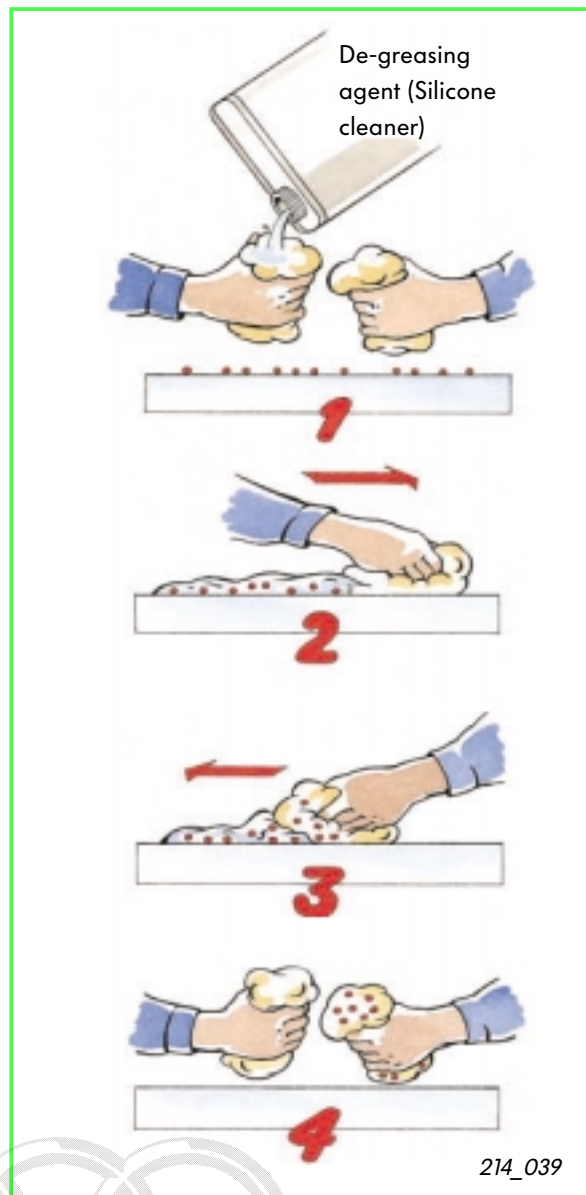

De-greasing the surface

Preparatory sanding

In order to achieve optimal adhesion, the base must exhibit the proper degree of roughness. Selection of the correct sanding coarseness is thus extremely important.

For smooth transitions from the painted surface to the bare metal, all the painted edges must be sanded.

The paint edges are smoothed using a vibrating sander and P80 or P100 sandpaper.

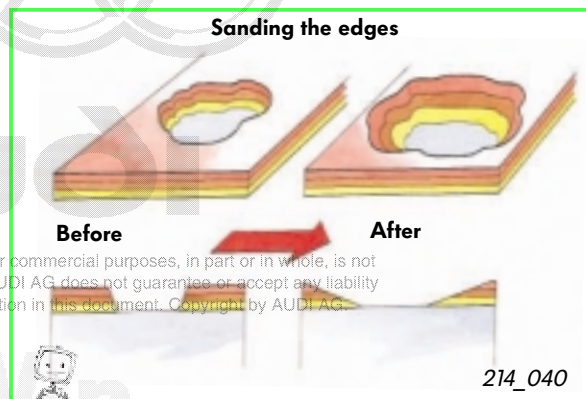

Preparatory sanding



Painting in the Repair Shop

The protective primer

Primer for bare metal

The production-standard corrosion protection should, as far as technically possible, be observed for all repair paint jobs.

If the pre-treatment exposes bare metal, one of the following protective primers must be used before application of the paint.

- Acid-hardening (phosphatising) protective primer
- Epoxy-resin based protective primer

Acid-hardening protective primer

Acid-hardening protective primer, also called **wash primer**, is a two-component product. Once the components have been mixed, the primer has a potlife of 24 hours at 20 °C.

The primer extender is applied after the wash primer has dried but still retains its corrosive properties.

Acid-hardening protective primer is easy to sand. Sanding should be carried out in a dry-sanding process with P400 sandpaper.

The ventilation time between spraying cycles should be about 5 minutes. Two to three coats can be applied, depending on requirements. The drying time before application of the extender is 30 to 90 minutes at 20 °C.

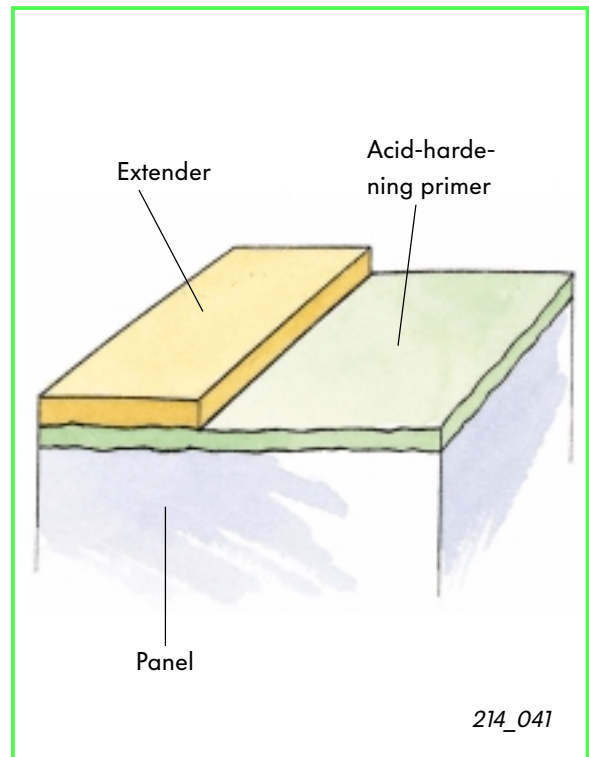

Acid-hardening primer



A polyester filler cannot be applied to an acid-hardened protective primer, because the still-wet filler will loosen the primer from the base. In this case, extender without primer is the better option.

The reverse, that is the application of an acid-hardened protective primer to hardened filler, is permissible because the filler is no longer chemically active.

Protected by copyright. Copying for private or commercial purposes, in part or in whole, is not permitted unless authorised by AUDI AG. AUDI AG does not guarantee or accept any liability with respect to the correctness of information in this document. Copyright by AUDI AG.



Epoxy-resin based primer

Primers with an epoxy resin basis are compatible with polyester filler, regardless of the thickness of the layer.

The drying film may be very thick, enabling the primer to act as an extender.

The drying time of approx. 4 hours at 20 °C is relatively long.

This primer serves as corrosion protection for the area to be filled, so that the filler is not applied directly to the bare metal.

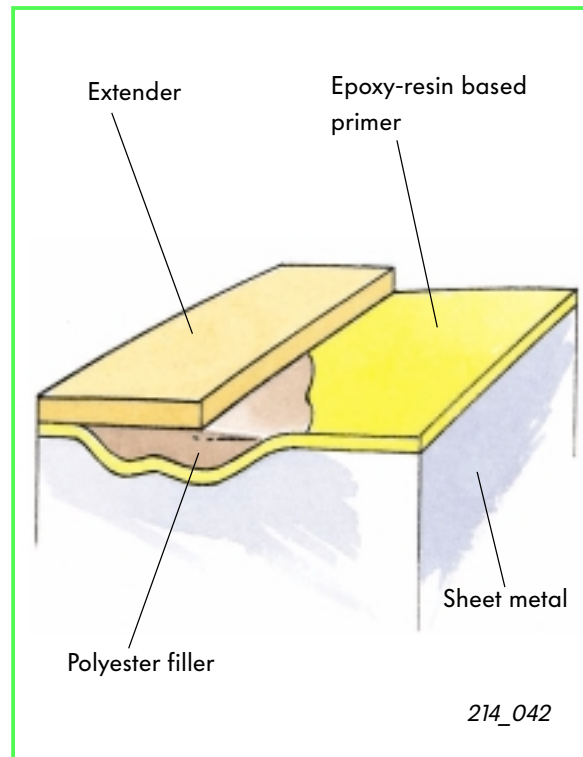

Epoxy-resin based primer

Note:

Both paint and primer retain their **corrosive properties** until they have dried. An additional coat of compatible paint can be applied without any intermediate sanding (wet-on-wet application).

If the paint has lost its corrosive properties, fine sanding will be necessary.

The **drying time** is divided into three phases:

- **Dust drying:** Dust no longer sticks to the paint. Imprints can still be made by applying light pressure.
- **Assembly drying:** The painted part can be installed. Imprints can only be made by applying strong pressure. The paint has not yet hardened.
- **Dried through:** The painted part can be put to its proper use or sanded.



Painting in the Repair Shop

The filler

Polyester filler

The polyester filler may only be applied in thin layers. Layers which are too thick - due to defective panel restoration - can lead to a poor quality finish.

Polyester filler consists of two components which must be mixed directly before application.

Resin and hardener (catalyst).

Hardener must always be added in the amounts prescribed by the manufacturer, normally 2 to 3 grams per 100 grams of filler (2 to 3 percent of the weight).

Filler and the red-coloured hardener are mixed with a spatula until the mixture (homogenization) is optimal and no traces of red hardener are visible.

Mixed filler has a short potlife - only about 5 to 10 minutes.

It must therefore be applied quickly and precisely.

The filler tools may be cleaned with a universal solvent.

Only mix as much filler as required. With time, the filler loses its ability to be spread as well as its bonding properties.

● **Not enough hardener (catalyst)**

The filler does not harden within the planned time. Sanding is made more difficult, the abrasive medium becomes clogged and leaves behind sanding tracks and drag lines.

● **Too much hardener (catalyst)**

The filler does not harden more quickly. The active hardener is left over to react with the resin, the extender and topcoat pigments. The result is changes in colour and the formation of spots or contours.

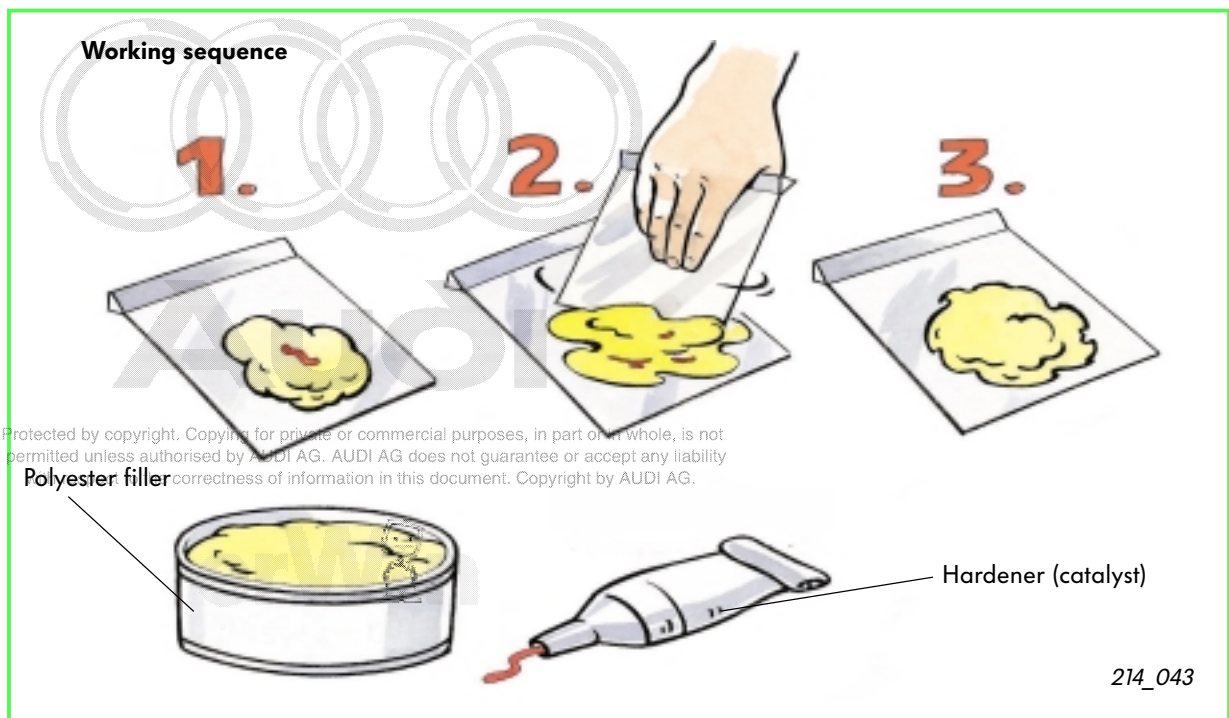

Mixing polyester filler

Application of filler

The quality of the repair paint job is determined in large part by how well the quality of the filler application.

Motto:

The more time spent applying the filler, the less time spent sanding.

Restored sheet metal areas must first be degreased and sanded.

Post-sanded filler layers thicker than 400 to 500 µm are not acceptable.

Polyester filler may only be used on bare steel, because it has insufficient adhesive properties on galvanised steel.

Universal filler is the better option in that case, since it adheres excellently to both steel and galvanised steel.

Another possibility is the application of polyester filler on a coat of epoxy-resin primer.

Note on preparing filler:

During storage, solid particles in the filler may sink to the bottom, and resin may rise to the top. Always stir the contents of the container thoroughly in order to ensure proper mixing of resin and solid extenders.

The extenders would not otherwise take part in the reaction, resulting in an altered mixing ratio with the hardener.

Use only clean tools to remove the filler from the container. Residues of filler or hardener cause a reaction in the container, rendering its contents unusable.

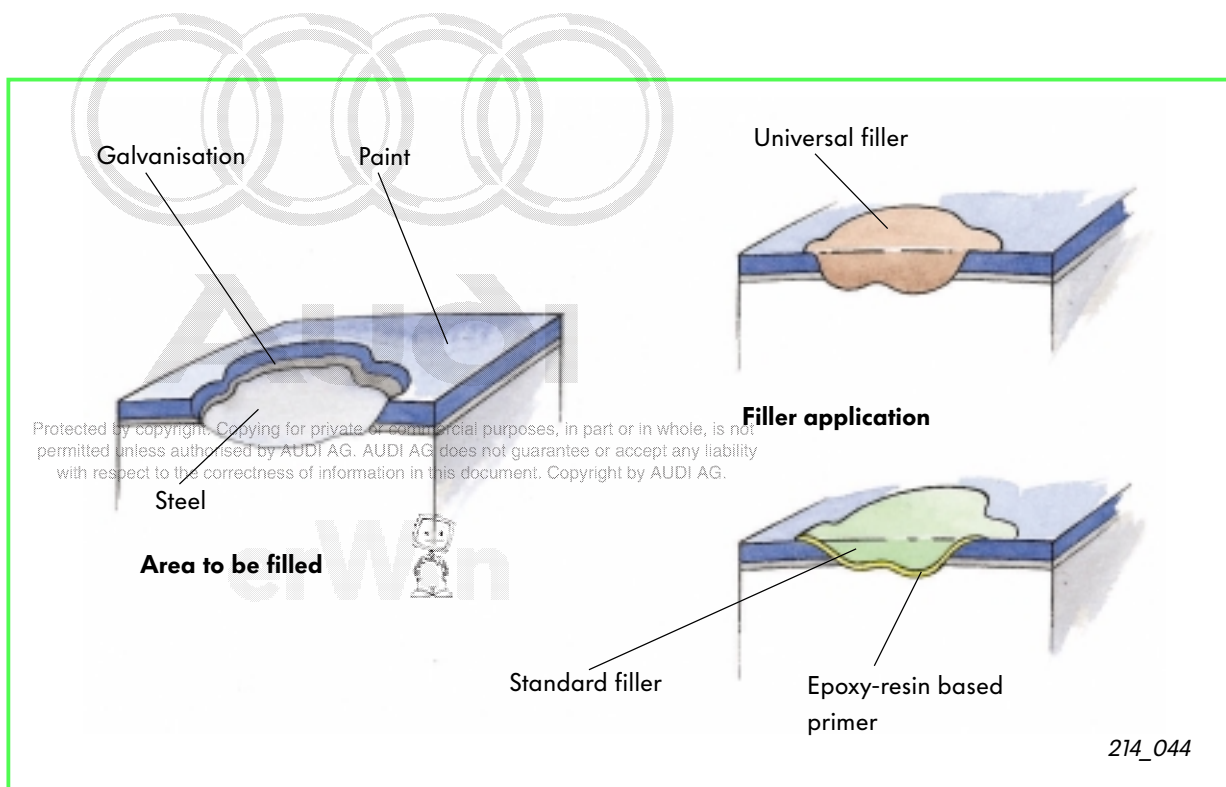

Application of filler on a galvanised panel

Painting in the Repair Shop

Sanding the filler

Polyester filler dries and hardens relatively quickly - in about 30 minutes at 20 °C. The sanding work can thus be carried out shortly after the filler has been applied. Insufficient drying of the filler - like incorrect admixture of hardener - leads to the following sanding problem: The abrasive becomes clogged with sticky resin residue. Cleaning the surface with a cleaning solution makes the sanding process faster, more comfortable and more effective.

Medium-grain sandpaper, P80 or P120, is the best choice for the main sanding procedure. Then sanding tracks can then be removed with fine-grain P240 sandpaper.

The sanding work can be performed manually with a sanding block and plane, or with the aid of an electric sander. For large, smooth surfaces, the most appropriate tool is the vibrating sander. The eccentric sander is a better match for irregular surfaces.



Polyester filler may only be sanded after it has dried completely. **Water may not be used.** Polyester filler tends to absorb moisture, resulting in the formation of “bubbles” during the heat-drying of the topcoat. Wet-sanding also increases the risk of corrosion.



Manual sanding tools

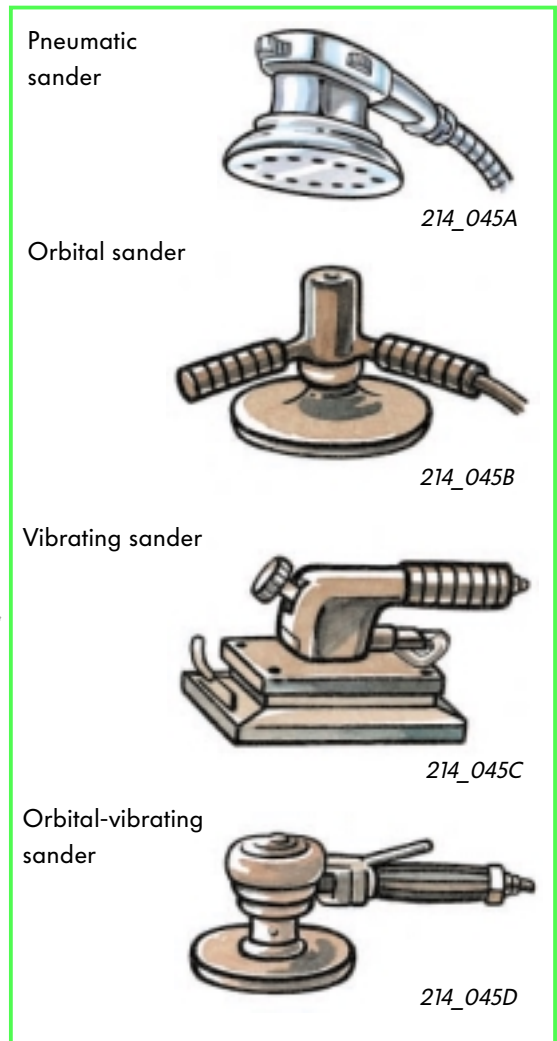

Sanding tools

If more filler needs to be applied after the sanding process, the sanding residue may be removed with a compressed-air gun, solvent and paper towels.

As a rule, only two applications of filler should be necessary.

To protect against damage and soiling during the application of filler - and especially during sanding, securely cover all adjacent areas.

Once the filler has been sanded, the areas of bare steel receive an application of protective primer and then extender.

The extender must be applied over a larger area than the filler, since the filled area must be completely covered with extender.

The painted areas bordering the filled areas are finely sanded or **mat-sanded**.

This area is 15-cm wide surrounding the entire filled surface.

Matting tools include:

- Abrasive pad
- Conventional abrasive medium
- Sanding machine

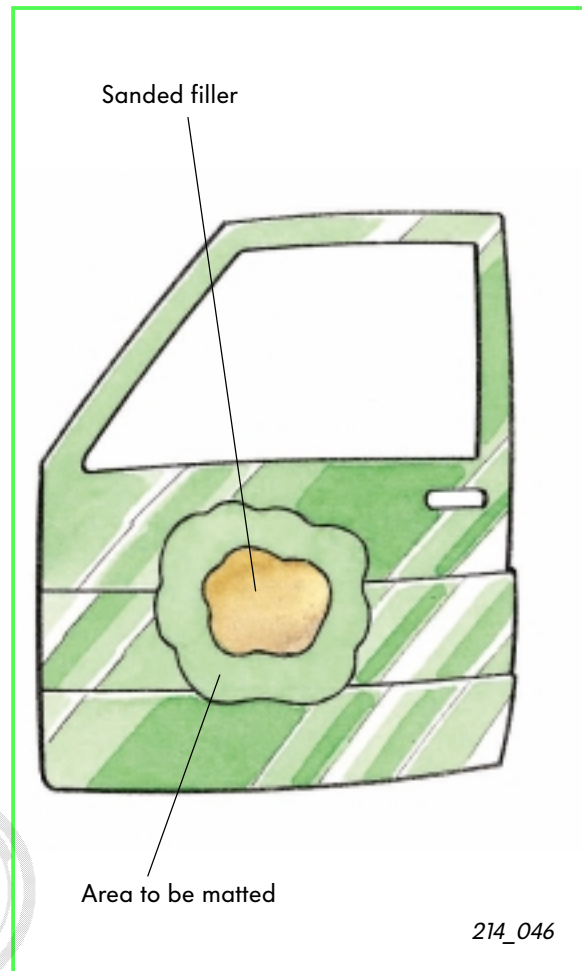

Matting

214_046

Audi

Protected by copyright. Copying for private or commercial purposes, in part or in whole, is not permitted unless authorised by AUDI AG. AUDI AG does not guarantee or accept any liability with respect to the correctness of information in this document. Copyright by AUDI AG.

erWin

Painting in the Repair Shop

Application of the primer extender

The primer extender forms an undercoat onto which the topcoat will be applied. The topcoat may only be applied onto the primer extender or the existing coat of paint.

Tasks of the primer extender

The primer extender, a preparatory material for painting, has the following tasks:

- Smoothing out restored areas.
- Covering the filler and primer layers.
- Providing an undercoat for the topcoat, in order to achieve optimum bonding and shine.

The topcoat may **not** be applied directly to the filler or primer. The results would be poor surface quality and application problems such as topcoat absorption.

The primer extender is a dual-component product with an acrylic base and a composition similar to that of 2C paint. The type of pigmentation varies.

Solid matter content

The filling capacity of the primer extender depends on its solid matter content.

The solid matter content is classified as follows:

- **Standard:**
Standard solid matter content
- **MS (medium solid):**
Medium solid matter content
- **HS (high solid):**
High solid matter content

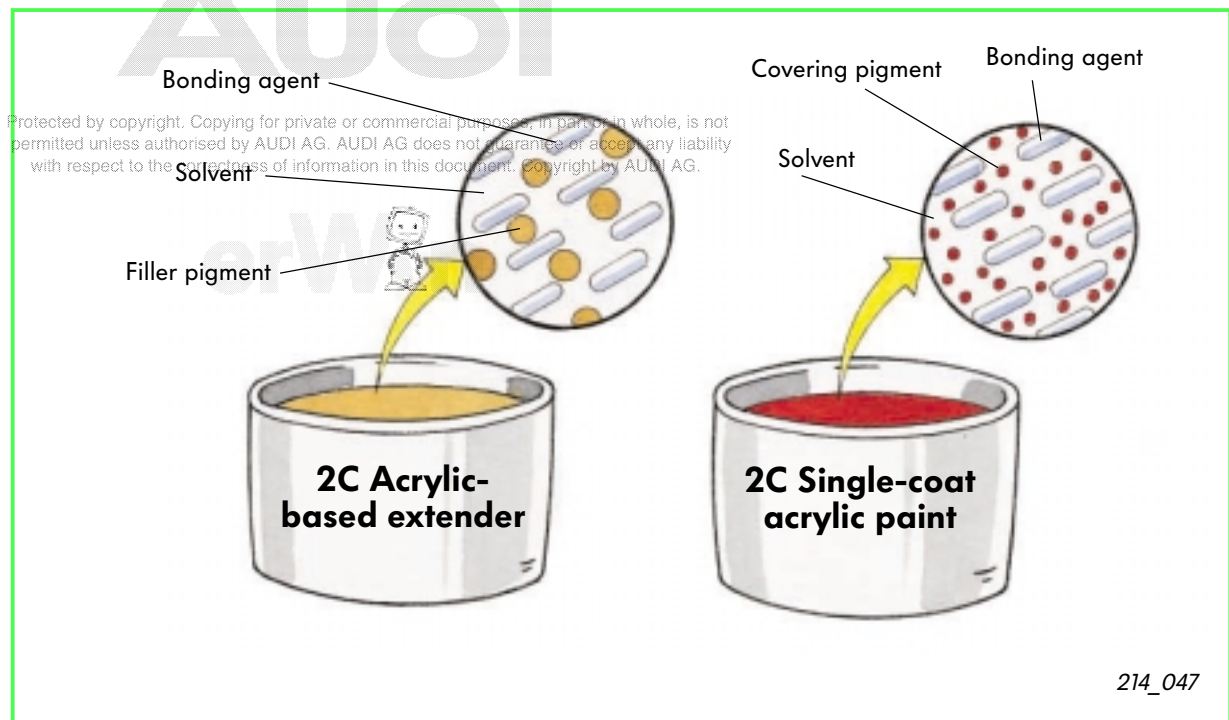

214_047

Dual-component primer extender

Application procedure

One option is the **wet-in-wet procedure**. The primer extender is used as an intermediate or insulation layer, without compensation for surface irregularities.

The topcoat is applied while the primer extender still possesses its corrosive properties.

Sandable extender is the most commonly used application procedure. The primer extender hardens completely and is then sanded smooth.

Colourable extender is used to avoid numerous topcoat sprayings, which can result in colour variations.

Topcoat paint is added to the undercoat to give it the same colouring as the topcoat.

Formulas

The type of primer extender to be used depends upon the type of repair, i.e. the area to be painted.

Various application properties may be achieved through the selective use of the hardener, thinner and additives, as well as the mixing ratio.

The most important factor is the selection of hardener and thinner according to the processing temperature.

- "Fast" for temperatures under 18 °C
- "Medium" for temperatures between 18 and 25°C
- "Slow" for temperatures under 25 °C

The potlife of acrylic-based primer extenders is 30 to 60 minutes.

Do not use more extender than needed!

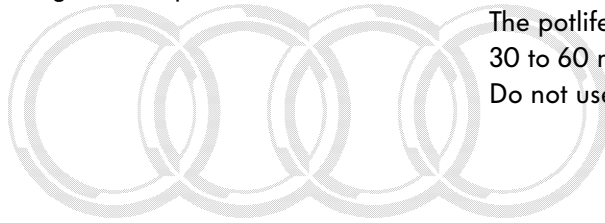

Audi

Guidelines for Using Primer Extenders

Protected by copyright. Copying for private or commercial purposes, in part or in whole, is not permitted unless authorised by AUDI AG. AUDI AG does not guarantee or accept any liability with respect to the correctness of information in this document. Copyright by AUDI AG.

Area to be painted	Suitable primer extender
Replaced panels	Standard or MS
Panel with small repair spots	MS
Restored panels	HS
Interior parts	Wet-in-wet
Normal surface quality (finish)	Wet-in-wet
High surface quality (finish)	Sandable
Colours with low covering capacity	Colourable

Painting in the Repair Shop

Application of the primer extender

For replaced parts or large-surface damages, the primer extender is applied to the entire panel.

For small damages, the primer extender must cover the filled and primed area(s).

The primer filler is applied with a spray gun whose nozzle is adjusted to the type of extender. The best results are attained in a spray chamber.

An HVLP spray gun (= high volume-low pressure) is the best choice for ensuring an even distribution of the primer extender.

To avoid problems resulting from insufficient drying, the prescribed evaporation times must be observed - especially with medium and high coat thicknesses.

The evaporation time between two coats is between 5 and 10 minutes.

Adjacent areas must be securely covered during application of the primer extender.

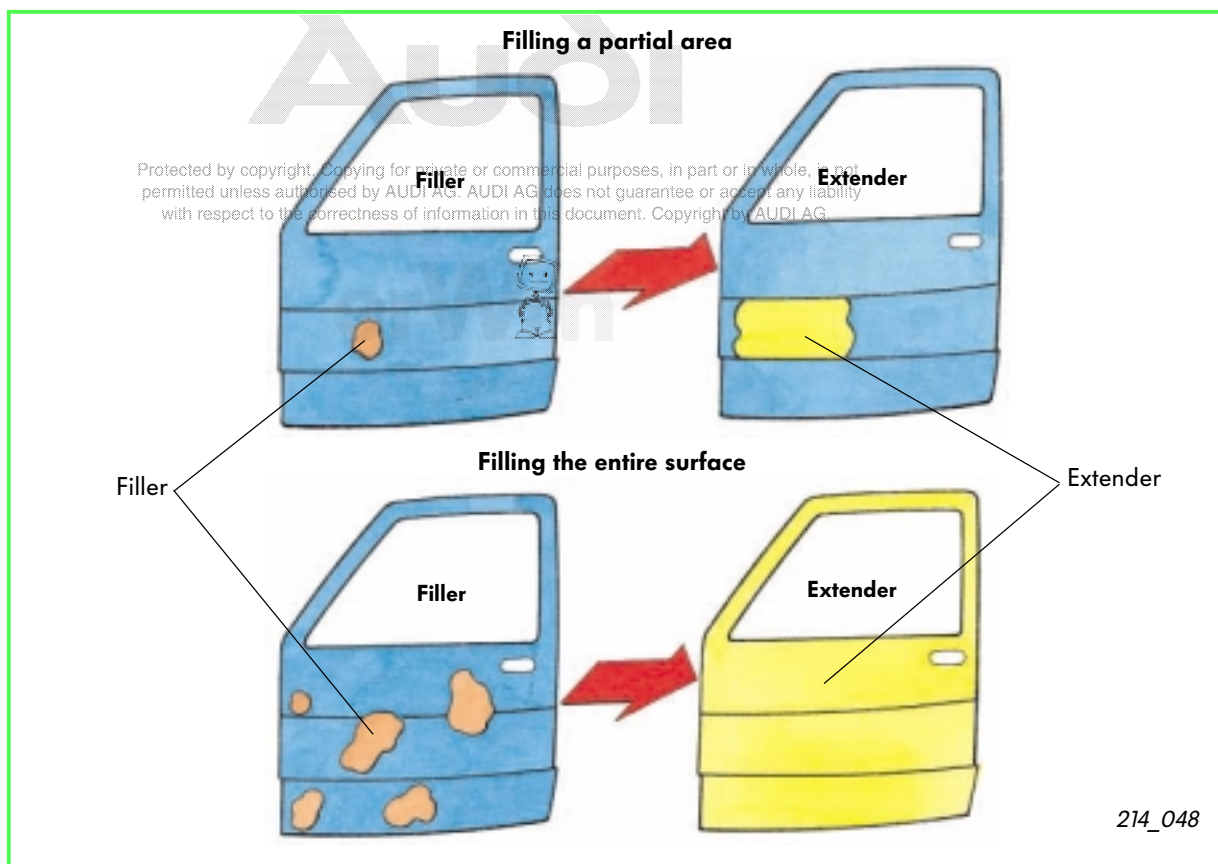
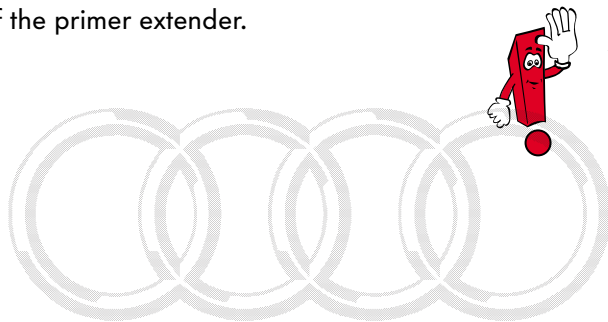

214_048

Spraying cycles

Sandable extenders require more than one spraying cycle in order to fully compensate deformations.

For small repairs, the coat of primer extender must be thicker on the filled surface than in the surrounding area.

When spraying cycles of sandable extender, each cycle must cover a larger surface area than the subsequent cycle.

The reason

With each spraying cycle, mist from the extender material settles on the edge of the coated area.

If the next spraying cycle covers this deposit, the sanding process will expose it again, leading to absorption problems during application of the topcoat.

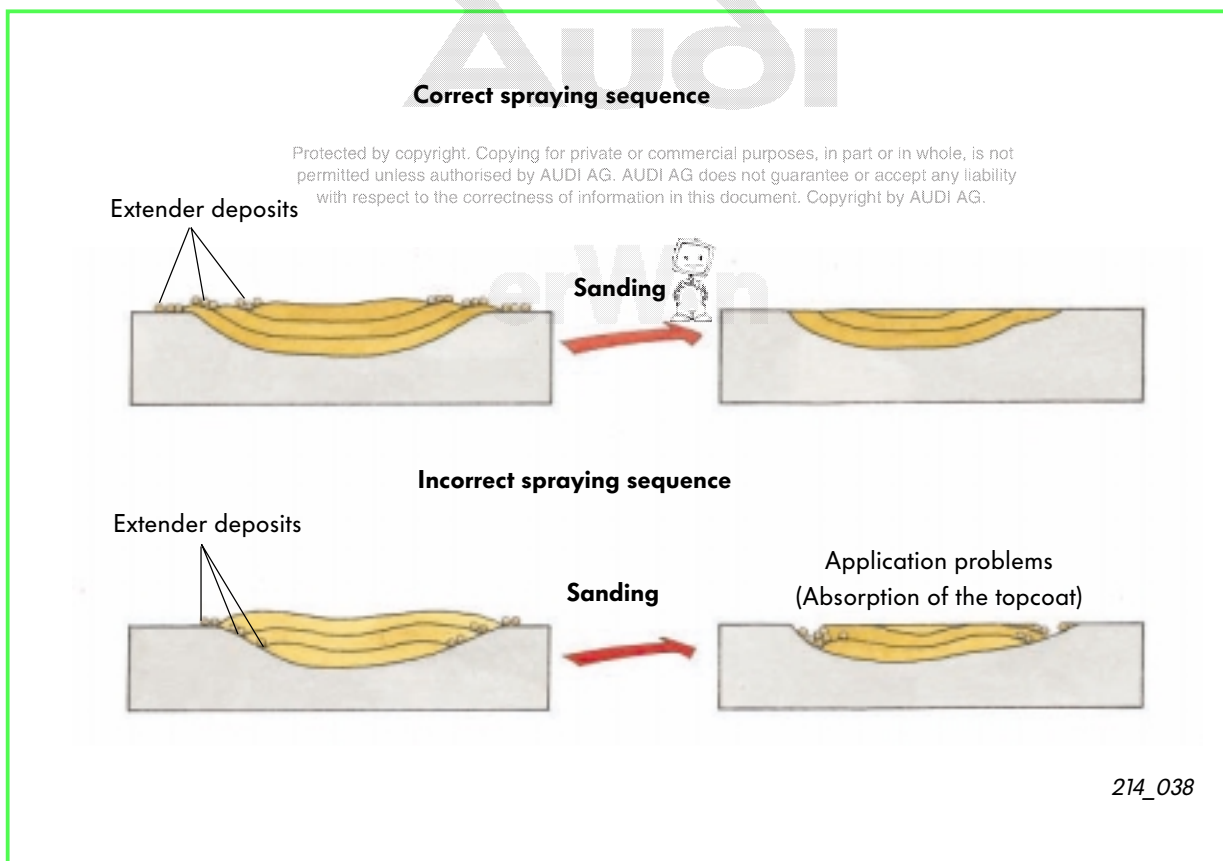
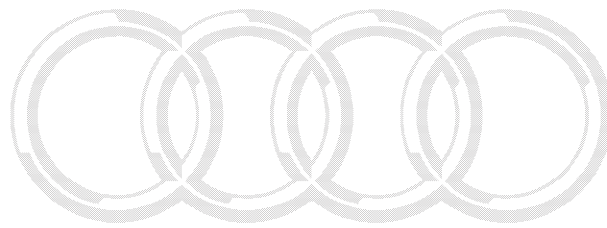

Painting in the Repair Shop

Sanding the primer extender

The primer extender must be sanded carefully. Errors in the primer-extender layer are visible even through the topcoat.

The primer extender may only be sanded after it has completely dried through.

This factor is especially important when working with thick extender layers.

Sanding incompletely dry primer extender will leave sanding tracks on the surface and can also clog the abrasive medium.

The drying time varies according to the type and coat thickness of the primer extender. It is normally between 3 and 12 hours at 20 °C.

The sanding process consists of two steps:

- Coarse sanding
- Fine sanding

In the first step, a coarse-grain abrasive smooths the primer-extender layer down to the level of the panel surface.

The fine-sanding step creates the surface structure necessary to cover sanding tracks and ensure that the topcoat bonds tightly. A fine-grain abrasive is used for this step.

Incorrect procedure for sanding the primer extender.

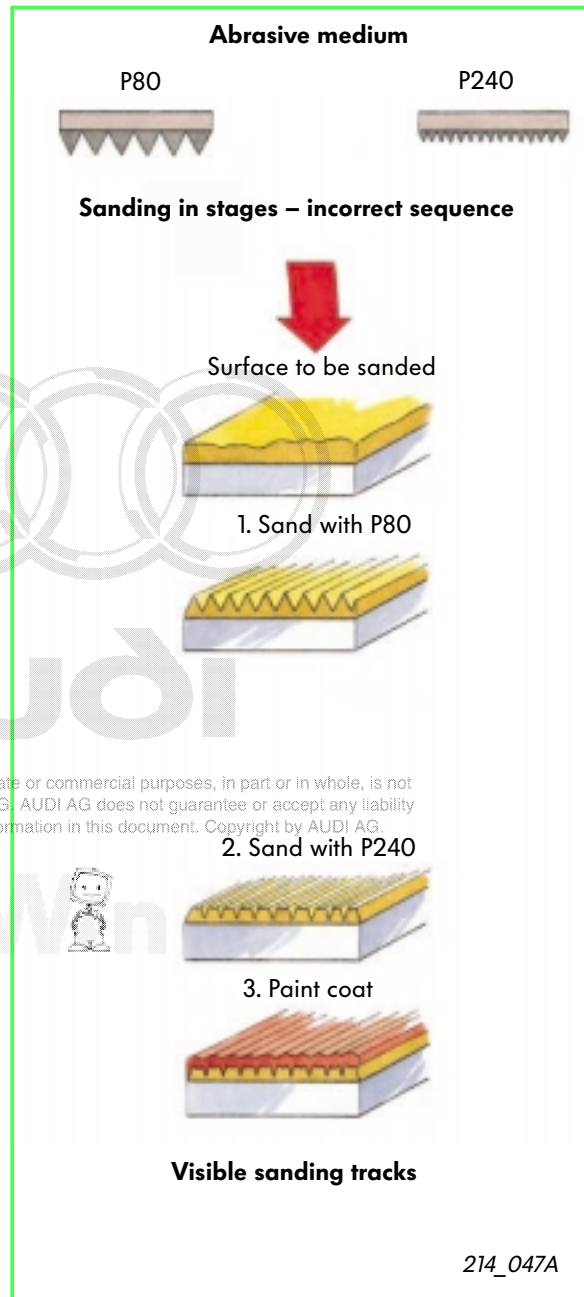

Visible sanding tracks



Correct procedure for sanding the primer extender

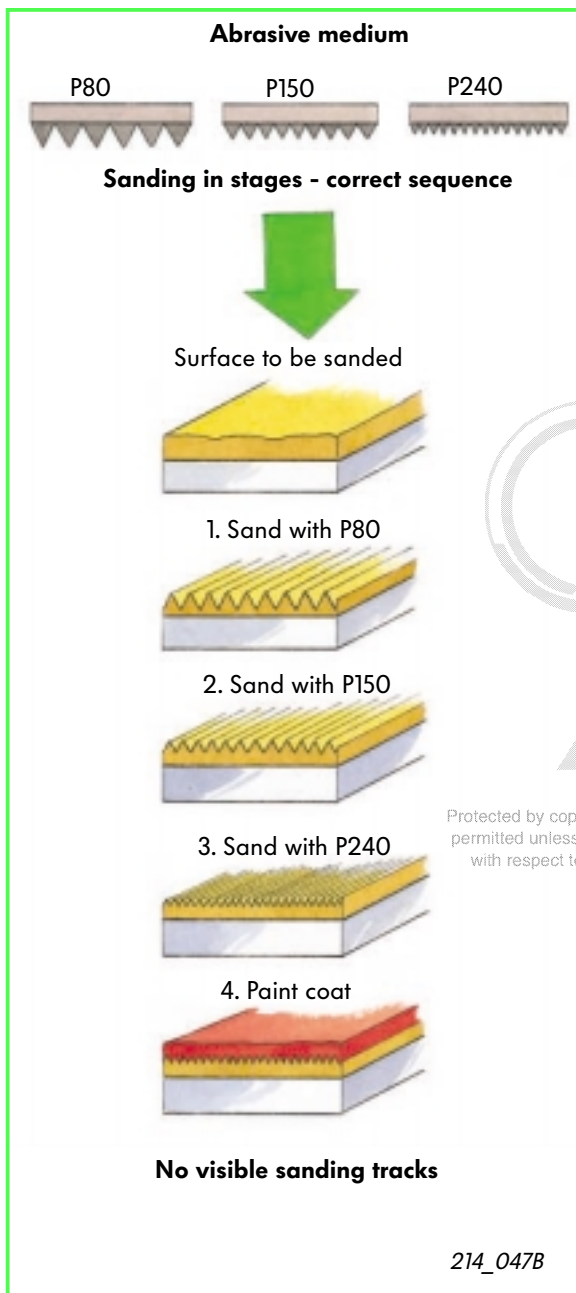

No visible sanding tracks

Sanding in stages

The stage-sanding process starts with a coarse abrasive and ends with a fine one.

If the jump from one coarseness to the next is too great, the channels left by the sanding passes will not be sufficiently covered by the next stage.

According to the FEPA norm (see Page 8), no more than three levels towards a finer grain may be skipped.

Finish sanding for one-coat and two-coat topcoats

The selection of a finish-sanding grain size depends on whether the subsequent painting is to proceed with one coat or two.

The film thickness of one-coat paint is greater than that of two-coat. With two-coat paint, only the base paint - and not the clear lacquer - contributes to covering the sanding tracks. One-coat paint thus covers deeper sanding tracks.

Dry sanding and wet sanding

Primer extender may be sanded wet or dry. Dry sanding, however, achieves the same surface quality more quickly than wet sanding. Wet sanding is performed manually and produces large amounts of sanding residue. Dry sanding is performed with sanding machines equipped with a suction system. Wet sanding permits the use of finer abrasives than dry sanding, because the water provides an additional sanding effect.



Protected by copyright. Copying for private or commercial purposes, in part or in whole, is not permitted unless authorised by AUDI AG. AUDI AG does not guarantee or accept any liability with respect to the correctness of information in this document. Copyright by AUDI AG.

Check Your Knowledge

1.) What is oxidation?

- A A chemical reaction of water with a metal surface.
- B A chemical reaction by which electrons are exchanged between two substances.
- C A chemical reaction of atmospheric oxygen with a metal surface.

2.) What is a voltaic cell?

- A The mutual interaction of anode and cathode.
- B The mutual interaction of two cathodes.
- C The mutual interaction of two anodes.

3.) Why is zinc used to coat steel panels in vehicle production?

- A Because it has a higher oxidation tendency than steel.
- B Because it has a lower oxidation tendency than steel.
- C Because it increases the rigidity of the panel.

4.) Which minerals are used in abrasives?

- A Emery, corundum, quartz
- B Emery, corundum, silicon carbide
- C Emery, corundum, carborund
- D Corundum, silicon carbide, diamond

Protected by copyright. Copying for private or commercial purposes, in part or in whole, is not permitted unless authorised by AUDI AG. AUDI AG does not guarantee or accept any liability with respect to the correctness of information in this document. Copyright by AUDI AG.

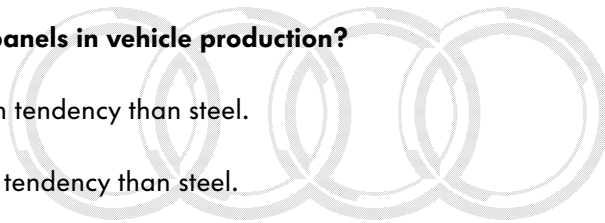

Audi

erWin 



5.) Which of the following statements about abrasive coarseness are true?

- A The particle size is standardised according to the FEPA scale.
- B The particle size is designated by a number, followed by a **P**, followed by a number.
- C The coarseness of the abrasive is determined according to the average size of the individual grains.

6.) What is a primer?

- A A base coat for sealing pores
- B A base coat for compensating irregularities
- C A bonding layer for the topcoat
- D A layer for corrosion protection

7.) What are the primary components of paint?

- A Bonding agents, solvents, extenders
- B Bonding agents, pigments, solvents, additives
- C Pigments, solvents, hardeners
- D Bonding agents, hardeners, additives

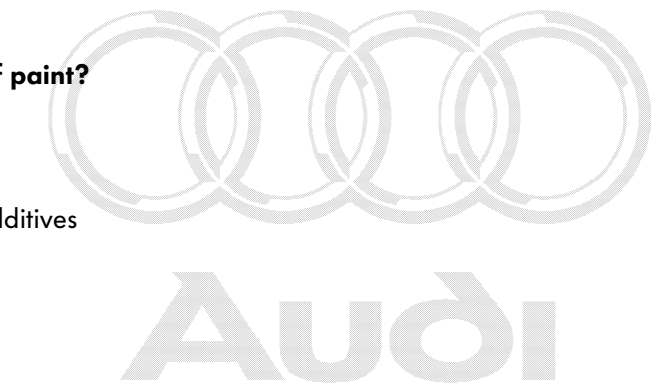

Protected by copyright. Copying for private or commercial purposes, in part or in whole, is not permitted unless authorised by AUDI AG. AUDI AG does not guarantee or accept any liability with respect to the correctness of information in this document. Copyright by AUDI AG.

8.) Which methods are available for drying vehicle paint?

- A Drying by evaporation of the solvent.
- B Drying by chemical reaction of the solvent with the bonding agent.
- C Drying by oxidation of the bonding agent.
- D Drying by bonding of the components (polymerisation).



Check Your Knowledge

9.) What is 2C paint?

- A Paint consisting of two main components: bonding agent and pigment.
- B Paint created by mixing two components before application.
- C Paint containing the two components catalyst and activator.

10.) Which is the correct sequence for body painting in the factory?

- A Phosphatising, cataphoresis, primer, topcoat.
- B Phosphatising, galvanisation, cataphoresis, primer, topcoat.
- C Galvanisation, cataphoresis, phosphating, primer, topcoat.

11.) What is cataphoresis?

- A A protective coat for the replacement parts for storage.
- B A protective primer for bodies and spare parts.
- C A dull black coat of paint.

12.) Which primer is the best choice for the bare areas of a replaced panel without filler?

- A Acid hardening primer.
- B An epoxy-resin based primer.
- C None of the above.

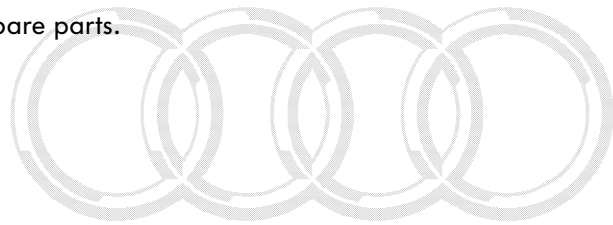

Audi

Protected by copyright. Copying for private or commercial purposes, in part or in whole, is not permitted unless authorised by AUDI AG. AUDI AG does not guarantee or accept any liability with respect to the correctness of information in this document. Copyright by AUDI AG.



13.) What is the difference between the sanding process for filler vs. extender?

- A Extender must always be sanded when dry, filler may also be sanded when wet.
- B Filler must always be sanded when dry, extender must be sanded when wet.
- C Filler must always be sanded when dry, extender may also be sanded when wet.

14.) What is an HS type of primer extender?

- A A material with high solid matter content.
- B A material with high pigmentation.
- C A material with high bonding agent content.

15.) MS extender is best suited to which type of surface?

- A Replaced panels
- B Panels with small repair surfaces.
- C Restored panels.
- D Interior parts.

16.) Which of the following describes the correct stage-sanding sequence for primer extenders?

- A Coarse sanding with P80, finish sanding with P240
- B Coarse sanding with P80, fine sanding with P150, finish sanding with P240
- C Both of the above.

Protected by copyright. Copying for private or commercial purposes, in part or in whole, is not permitted unless authorised by AUDI AG. AUDI AG does not guarantee or accept any liability with respect to the correctness of information in this document. Copyright by AUDI AG.

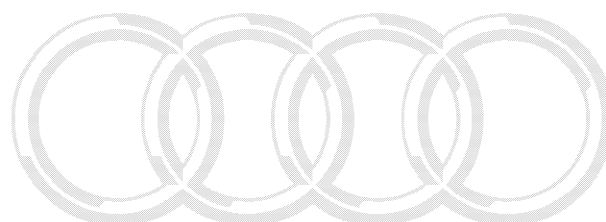

Glossary

Absorption

- 1) Physics: The partial or complete absorption of electromagnetic waves or particle radiation while passing through matter. The energy of the absorbed rays is converted to heat (absorption heat).
- 2) Chemistry: The absorption of gases and vapours through liquids or solid bodies and the even distribution within the absorbing substance.
- 3) Biology: The absorption of liquids, vapours, etc. via the cells.

Acetone

Colourless, aromatic, flammable liquid; important solvent and extraction medium.

Acrylic resin

Synthetic resin made of polymerized acrylic acid derivatives: colourless, thermoplastic masses.

Acrylic acid

Pungent-smelling carbonic acid; base material for polyacrylic acid and mixed polymerides (especially paints).

Activator

Substance which increases the effectiveness of a catalyst.

Aesthetic

Stylistically beautiful, tasteful, provocative

Carborundum

Extremely hard abrasive made of silicon carbide or aluminium oxide.

Coil

Thin, wound-up wire

Dispersion

Physics: (disperse system) a matter system (mixture) of two or more existing phases, where the one component (disperse phase) is distributed inside another (dispersing agent) in its finest form. The disperse phase as well as the disperse system can be solid, liquid or gaseous. Examples of dispersion include suspended solids, emulsions, aerosols (mist) and smoke.

Latex Paint

Paint made from a bonding-agent dispersion and pigments.

Duplex

Modifier of composite words with the meaning 'double'.

Electrochemical elements

Electrical sources in which chemical energy is converted directly into electrical energy. Non-chargeable primary or galvanized elements create electrolytic tension, whereby a solid conductor (metal/carbon rod) which is submerged in a conductive (watery) solution of an electrolyte; the dry element (ZnMn-, Alkali-Mn-, HgZn-, AgZn-cells) yields 1.5 volts; used in flashlights and small appliances. The most important rechargeable secondary element is the lead accumulator.

Electrodes

Conductive, usually metallic parts which either bridge electrical charge carriers between 2 mediums or create an electrical field. The positive electrode is called the anode, the negative is called the cathode.

Electrolytic

Conducts electrical current and is decomposed by it (of [aqueous] solutions)

Electrophoresis

General motion of electrically loaded particles in resistant mediums (e.g. filter paper) under electrical voltage.

Emulsifier

Agent (e.g. gum arabic) which facilitates the formation of an emulsion.

Epoxy resin

Epoxy resin, a liquid or solid artificial resin which can harden and which contains the epoxy groups; used as cast resins, paints

Protected by copyright. Copying for non-commercial purposes, in part or in whole, is not permitted unless authorised by AUDI AG. AUDI AG does not guarantee or accept any liability with respect to the correctness of information in this document. Copyright by AUDI AG.



Fungicides

Substances which even in low concentration can destroy fungi. The transition to a fungistat, which only stems the fungal growth, without killing is variable and is often only a question of the dosage and duration of application.

Catalyst

1) Chemistry: Substance which even in slight amounts changes the speed of a chemical reaction (catalyse), usually accelerating, without itself being used up. Important catalysts include vanadiumoxide, platinum, nickel, peroxide, activated carbon, organometallic complex compounds and ion exchangers.

2) Technical: Catalytic converter.

Cataphoresis

Electrophoresis-positively charged particle in the direction of the cathode.

Components

Constituents which can compose a whole, or into which the whole can be broken down, e.g. the components of a composite substance.

Crystalline

Exhibiting crystal structure; certain minerals and stones

Paints

Spreadable substances, of a certain quality, true or colloidal solutions of solid substances in volatile solvents, which after application and drying form upon the base a closed, bonding film.

Mohs

Mohs, Friedrich, German mineralogist. Introduced a standard of mineral classification and in 1812 developed a scale of hardness which was named after him (Mohs' hardness)

Oxidation

Oxidation is the reaction of chemical elements or compounds with oxygen (e.g. burning); from the standpoint of electron theory, oxidation is a procedure by the chemical elements or compounds release electrons which are absorbed by other substances (thus reducing the oxidation material). The opposite (and always coupled) process is called reduction.

Passivation

Chemistry: The formation of a electrochemical state (passivity) of a metal surface by which the metal becomes relatively resistant to chemical attack (dissolution, corrosion). A very thin, invisible pore-free oxide layer forms via anodic current or the oxidation medium, which protects the metal e.g. iron, aluminium, chrome.

Perforation

General: A series of holes punched successively through a substance.

Phenol

Benzol derivative with a hydroxyl group, colourless crystalline substance with a characteristic odour

Phosphates

Salts of the phosphoric acids

Pigment

Granular shaped colouring substance which is deposited in the cells, especially those of the skin. The pigment determines the colour of the tissue.

Polymerisation

The most important of the three reactions in manufacturing macro-molecules via the joining of unsaturated monomers or monomers with an unstable ring system e.g. epoxide, lactame, where no sub-molecular reaction product is split off. The products of polymerisation (polymers) consist of a mixture of polymers distinguished by their varying levels of polymerisation

Polyurethane

Multi-purpose synthetics (fibres, paints, foam material) produced via the polyaddition of isocyanates and alcohols

Reduction

Chemistry: The opposite reaction to oxidation, by which a chemical element or a compound absorbs electrons which have been released by another substance (the reduction medium, which is thereby oxidised).

Sandpaper

Solid paper (or linen cloth) on which abrasive grains are glued; varies according to the abrasive: glass, sand, emery etc. Waterproof sandpaper is used for wet-sanding primers and paints.

Sedimentation

Process of stone formation through the deposit of stone fragments, the separation of dissolved components in solutions, enrichment of plants and animals.

Protected by copyright. All rights reserved. No part or in whole, is not permitted unless authorised by AUDI AG. AUDI AG does not guarantee or accept any liability with respect to the correctness of information in this document. Copyright by AUDI AG.



Glossary

Silicon carbide

Silicon carbide, silicon-carbon compound; serves both as an abrasive (Carborundum ®) and as a fire-proofing material.

Silicones

Synthetic, polymer silicon-organic compounds. Silicones are thermally and chemically very stable and water resistant, they are multi-purpose, e.g. the silicone oils (with short molecular chains) are used as hydraulic liquids, lubricants, foam separator and to impregnate textiles and paper; the silicone greases (with longer molecular chains) are used as lubricants and ointment bases; Silicon caoutchouc (with long, vulcanised e.g. with peroxide diluted molecular chains) are used as a durable, elastic, weather-resistant, acid and lye-proof sealants and the silicone resin (with spatially strong diluted molecules) as electric insulation and as a raw material for temperature-resistant paints.

Silicone

Extremely heat- and water-resistant synthetic containing silicon

Stearate

Salts of the stearic acids (chemical).

Viscosity

Viscosity, inner friction, those properties of a liquid or a gaseous medium (fluids), which, during deformation, yield friction tension in addition to thermodynamic pressure and cause the displacement of mutually reacting liquid or gaseous particles.

Cellulose

The primary component of the vegetable cell wall

Zinc

Chemical symbol Zn, metallic chemical element from subgroup II of the periodic table of elements; atomic number 30;

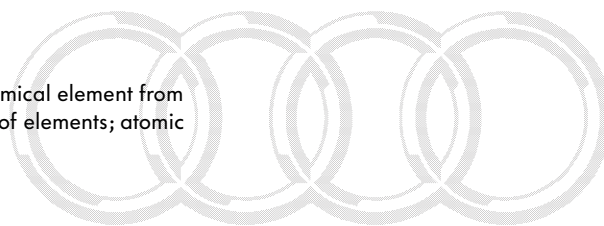

Audi

Protected by copyright. Copying for private or commercial purposes, in part or in whole, is not permitted unless authorised by AUDI AG. AUDI AG does not guarantee or accept any liability with respect to the correctness of information in this document. Copyright by AUDI AG.



erWin 

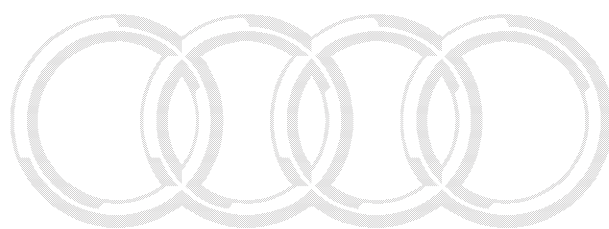

Audi

Protected by copyright. Copying for private or commercial use is not permitted unless authorised by AUDI AG. AUDI AG does not guarantee or accept any liability with respect to the correctness of information in this document. Copyright by AUDI AG.

Solutions to the test questions:

1: B / 2: A / 3: A / 4: B / 5: A, B, C / 6: A, C, D / 7:

B / 8: A, C, D / 9: B / 10: A / 11: B / 12: A, B / 13:

C / 14: A / 15: A, B / 16: B





2 : 1

2 : 1

2 : 1

2 : 1

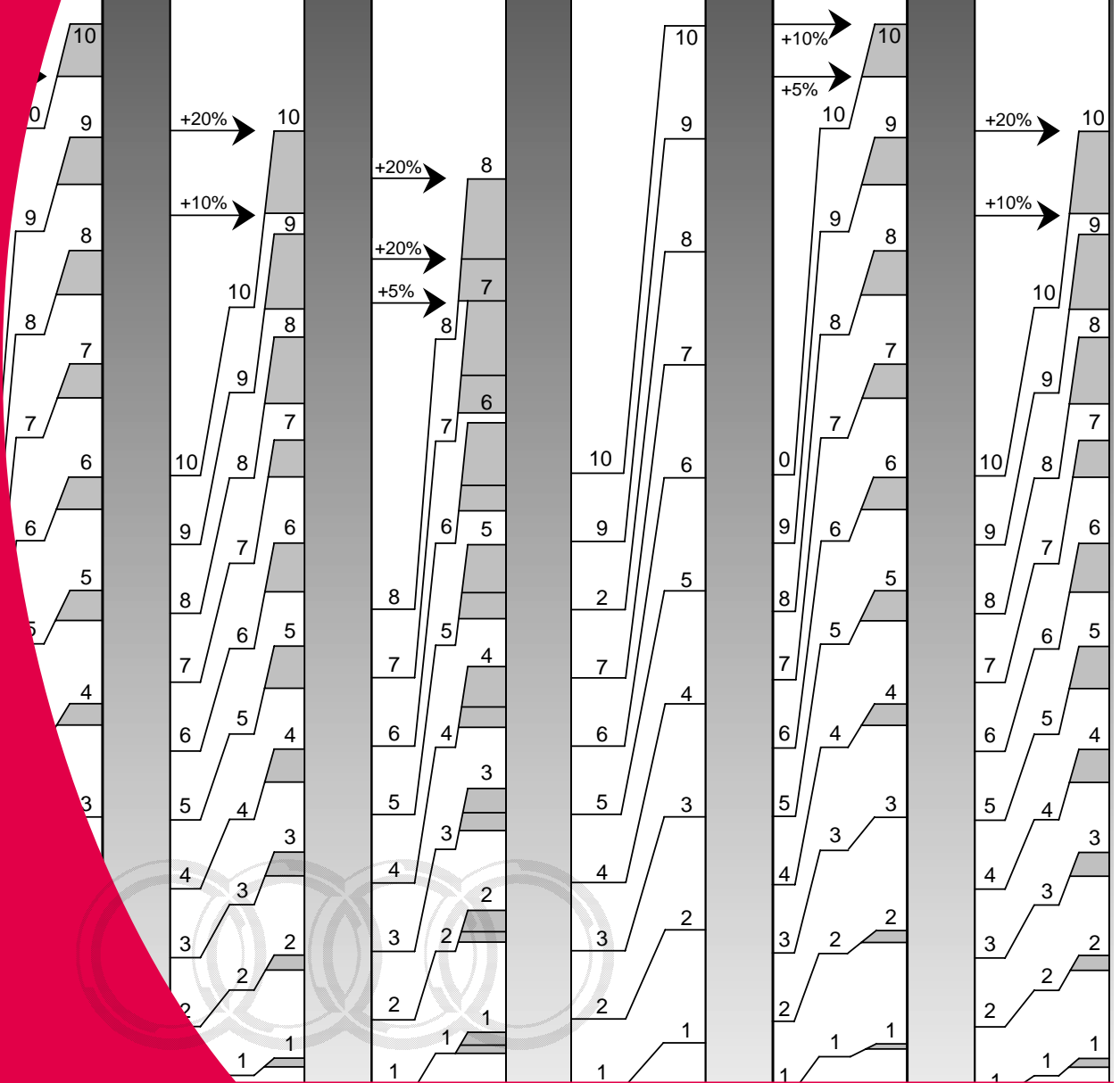

Only for internal use © VOLKSWAGEN AG, Wolfsburg

All rights reserved

Protected by copyright. Copying for private or commercial purposes, in part or in whole, is not permitted unless authorised by AUDI AG. AUDI AG does not guarantee or accept any liability with respect to the correctness of information in this document. Copyright by AUDI AG.

940.2810.33.20 Issued 03/99



No chlorine was used to bleach this paper during manufacture.