

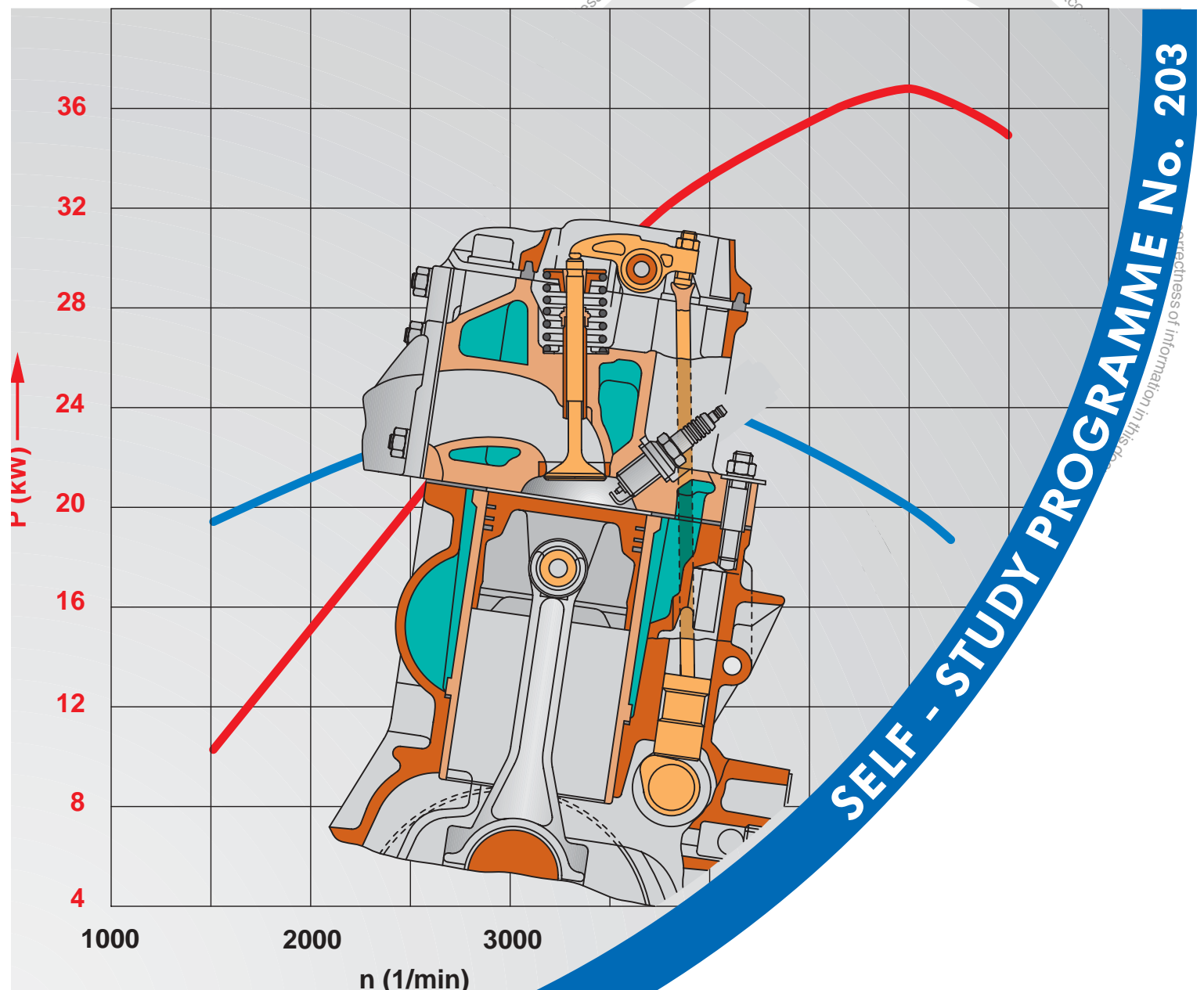

# The 1.0-ltr. 37 kW petrol engine with camshaft in block (ohv)

Design and function

... authorised by Volkswagen AG. Volkswagen AG does not guarantee or accept



In the Lupo, VW will be extending its range of petrol engines with a new 1.0-ltr. engine with aluminium block with camshaft in block (ohv).

It conforms to the exhaust emission standards EU III and D3.

This compact and light-weight engine is an in-Group development and is based on proven engine components.

mitted unless authorised by Volkswagen Financial Services AG does not guarantee or accept any li

... purposes, in part or in...



In this Self-Study Programme, we will explain to you the design and function of this new engine.



## Specifications ..... 4

Engine data  
Engine overview



## Engine mechanicals ..... 6

Crankshaft  
Cylinder block  
Cylinder liner  
Timing gears  
Valve timing adjustment  
Oil pump  
Valve timing  
Drives for auxiliary components  
Coolant pump



## System overview ..... 10

Engine management system Simos 2P  
Sensors/actuators



## Sensors ..... 14

Engine speed sender G28 and TDC recognition  
Intake manifold pressure sender G71 and intake air temperature sender G41  
Knock sensor G61



## Injection system ..... 17

Intake module with injectors



## Functional diagram ..... 18

## Self-diagnosis ..... 20

## Test your knowledge ..... 21



New



Important Note



The Self-Study Programme is not a Workshop Manual.

Please always refer to the relevant Service Literature for all inspection, adjustment and repair instructions.

# Specifications



## Engine data

**Engine code:** AHT  
**Type:** 4-cylinder in-line engine  
**Displacement:** 997 cm<sup>3</sup>  
**Bore:** 72 mm  
**Stroke:** 61.2 mm  
**Compression ratio:** 10 : 1  
**Rated output:** 37 kW at 5000 rpm  
**Max. torque:** 84 Nm at 3250 rpm  
**Mixture preparation:** Simos 2P multipoint injection system  
**Fuel:** 95 RON unleaded. The vehicle can alternatively be operated on 91 RON fuel via the knock control with a slight reduction in torque and performance.

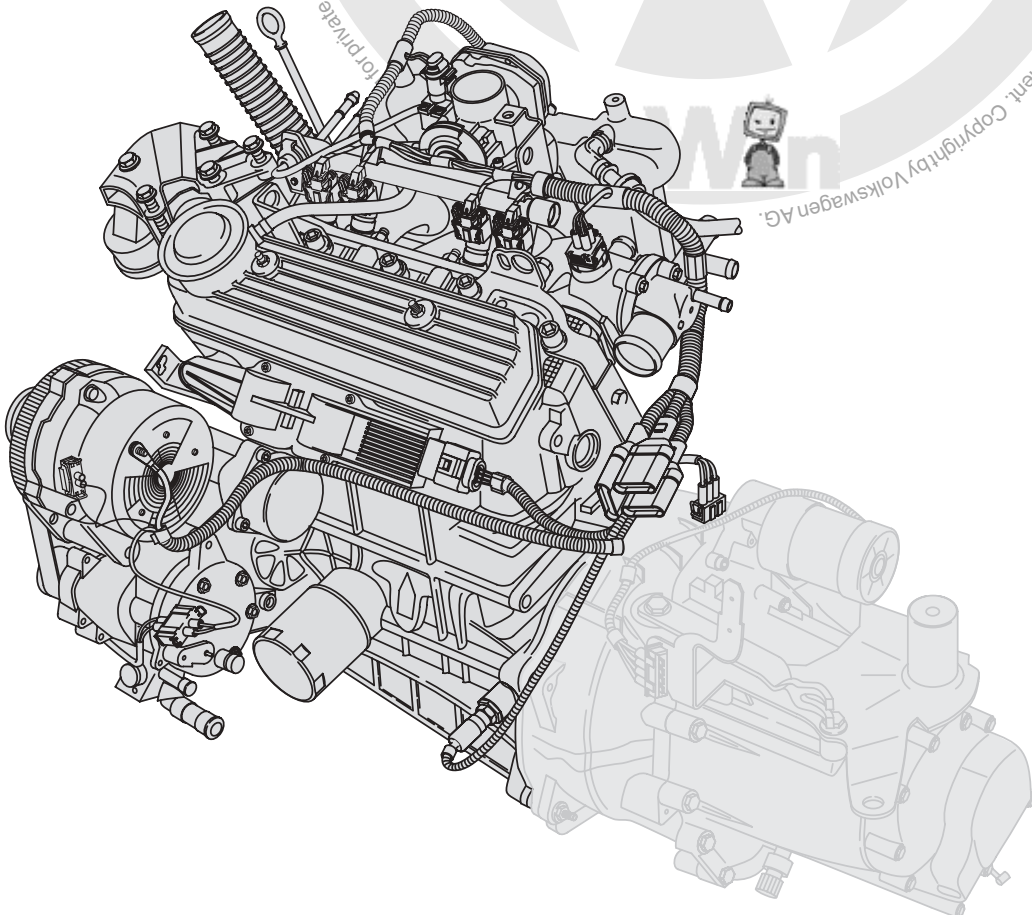
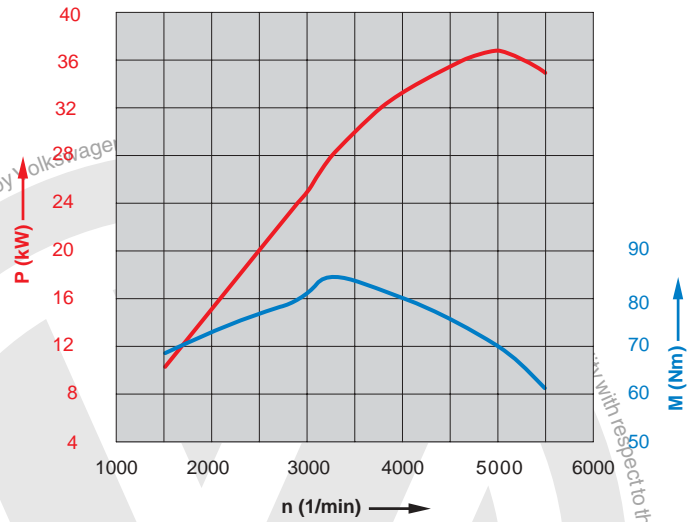

## Engine overview

The engine has a crossflow cylinder head with 2 valves per cylinder.

A twin roller chain drives the in-block camshaft (ohv).

Hydraulic tappets, push rods and rocker levers make for a play-free valve gear.

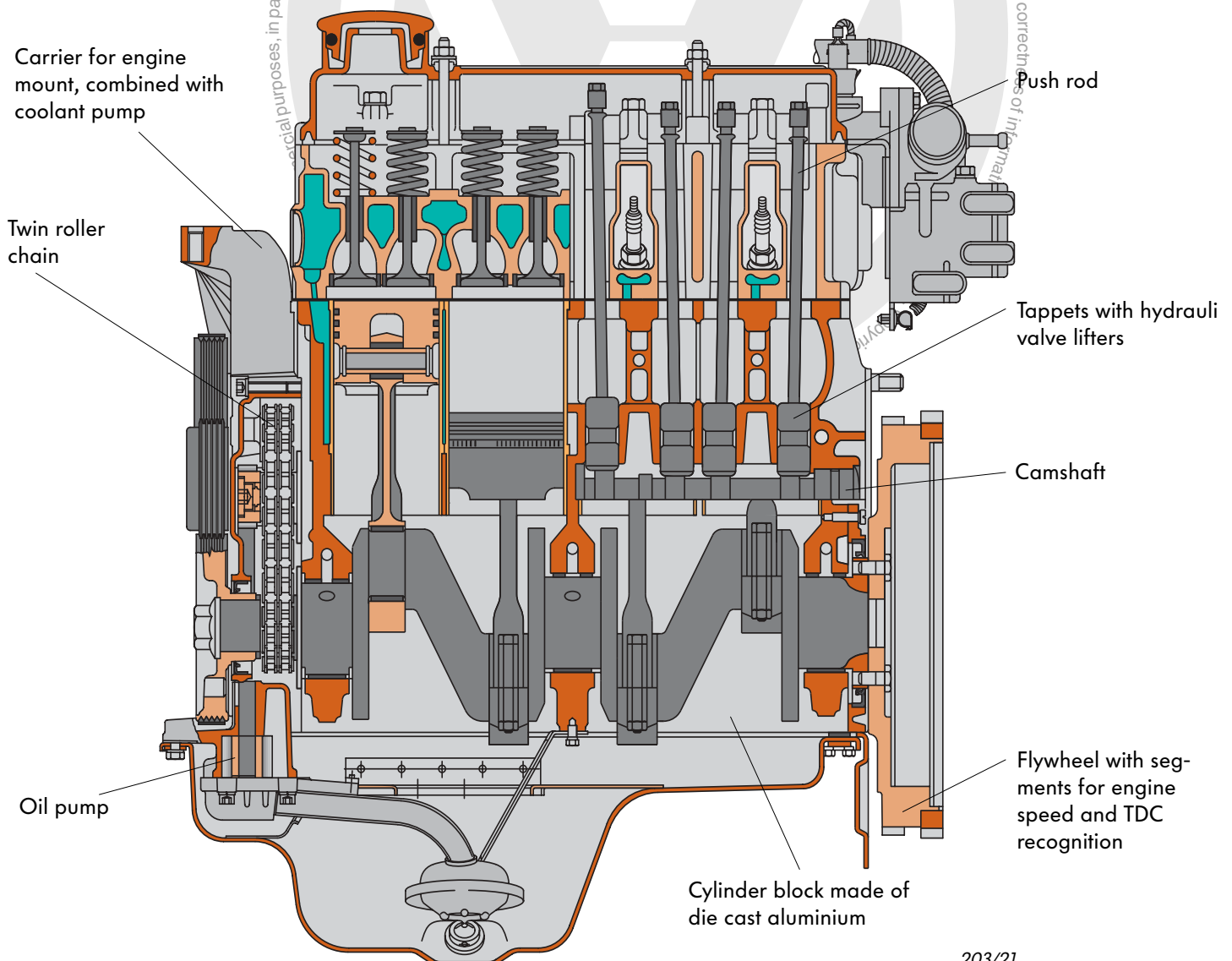

# Engine mechanicals

## Crankshaft

- Mounted in 3 bearings
- The main bearing (in the centre) is located in between the crankshaft journals of the 2nd and 3rd cylinders.
- The crankshaft is fixed in an axial direction by the centre main bearing.

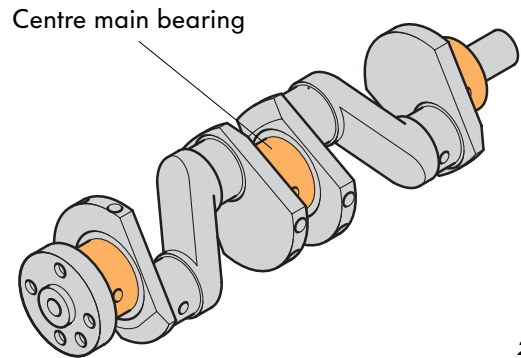

203/12

## Cylinder block

- made of die cast aluminium
- The cylinder liners are not an integral part of the cylinder block.

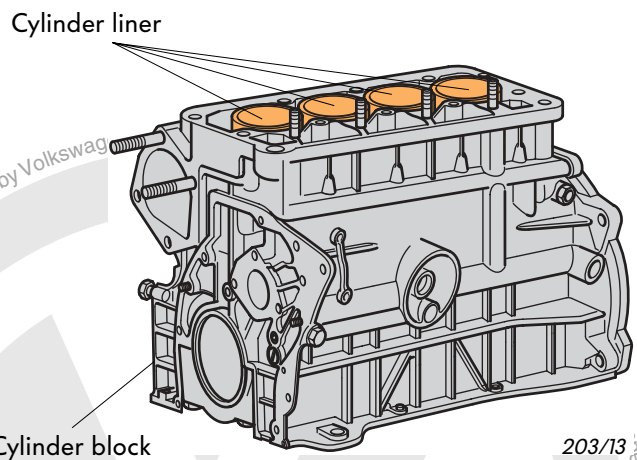

203/13

## Cylinder liners

- The four cylinder liners are made of grey cast iron and installed individually in the cylinder block. They are interchangeable.
- The cylinder liners are directly swept with coolant (wet type bushes).
- The lower section of the cylinder liners are sealed off from the cylinder block with copper sealing discs. Cylinder liner pretensioning is also adjusted with these sealing discs.



Pretensioning is measured during installation. 3 different thicknesses of copper sealing disc are available for adjusting the pretensioning.

- The pretensioned cylinder liner is sealed off from the cylinder head by means of the cylinder head gasket.

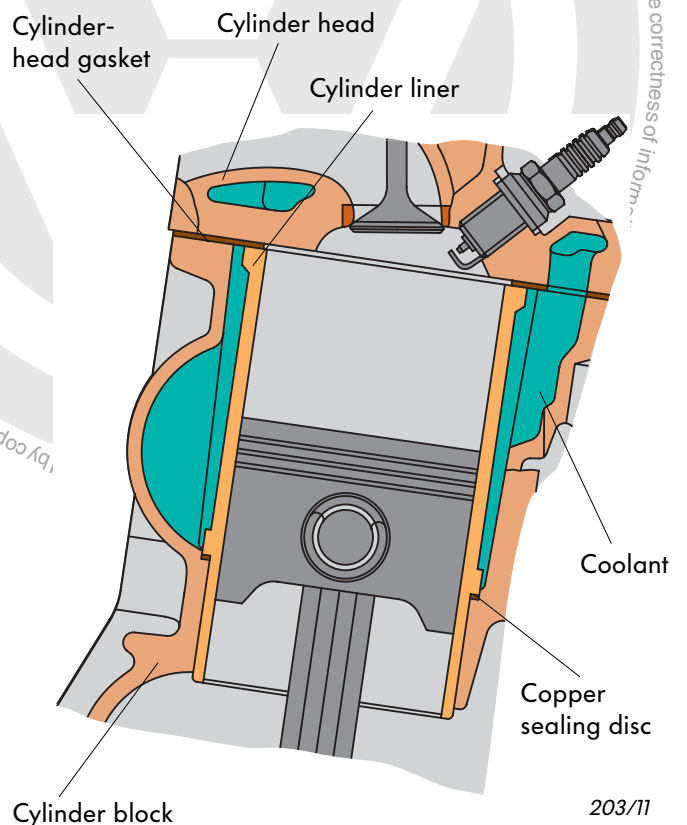

203/11

## Timing gears

- The in-block camshaft (ohv) is driven by the crankshaft by means of a twin roller chain.
- The whole drive is covered by the timing gear cover.

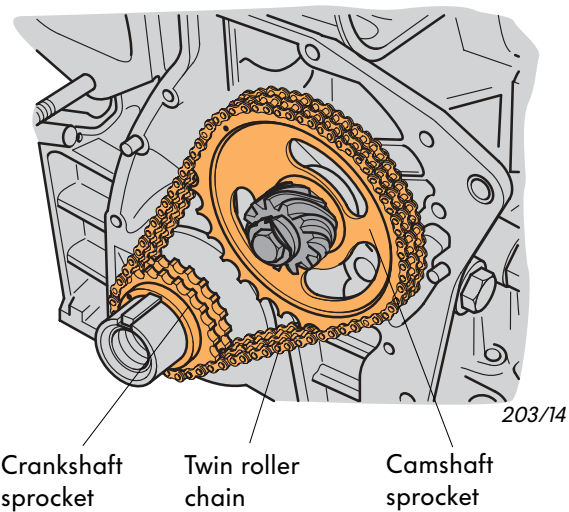

## Valve timing adjustment

The position of the sprockets on the shafts is set by means of a fitting key.

For adjusting the port timing, there is a mark on the crankshaft sprocket and on the camshaft sprocket.

The two sprockets are engaged in the chain so that the marks are separated by 12 chain pins.

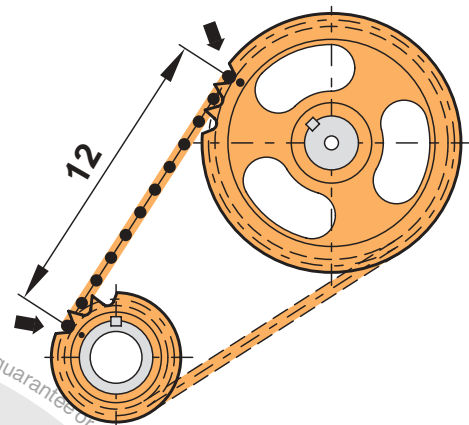

For detailed instructions on adjustment, please refer to the Workshop Manual.

## Oil pump

The oil pump drive and the oil pump are located below the timing gear cover. The oil pump is a gear type pump.

The oil pump is driven via the camshaft.

The oil pump gear is driven via worm gears and a vertical shaft.

The second oil pump gear is driven by the oil pump gear and revolves around a fixed journal.

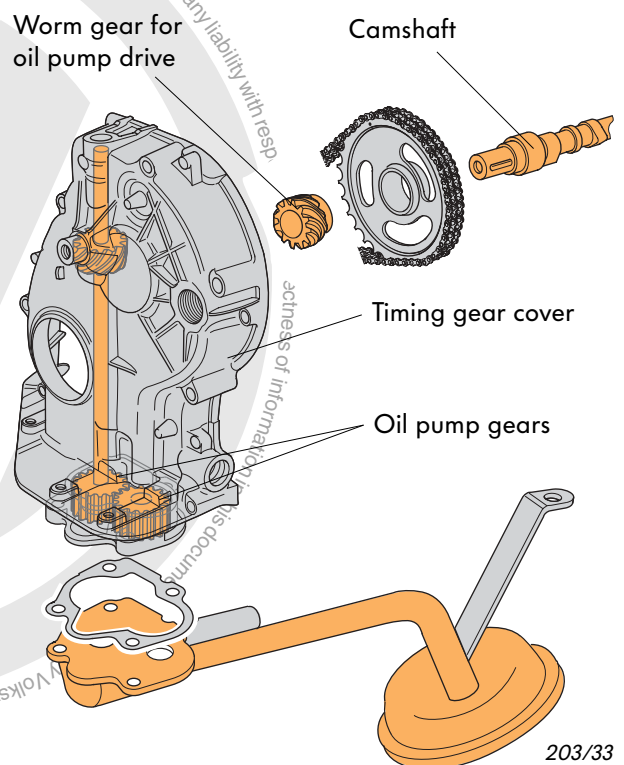

# Engine mechanicals

## Valve timing

The valves are activated by the in-block camshaft (ohv) via a push rod and rocker lever.

Valve clearance is adjusted by the hydraulic system in the tappet dependent on the engine oil pressure.

Valve clearance stays constant throughout the engine running time.

After carrying out repairs, re-adjust the valve clearance to basic position using the rocker lever adjusting screw.

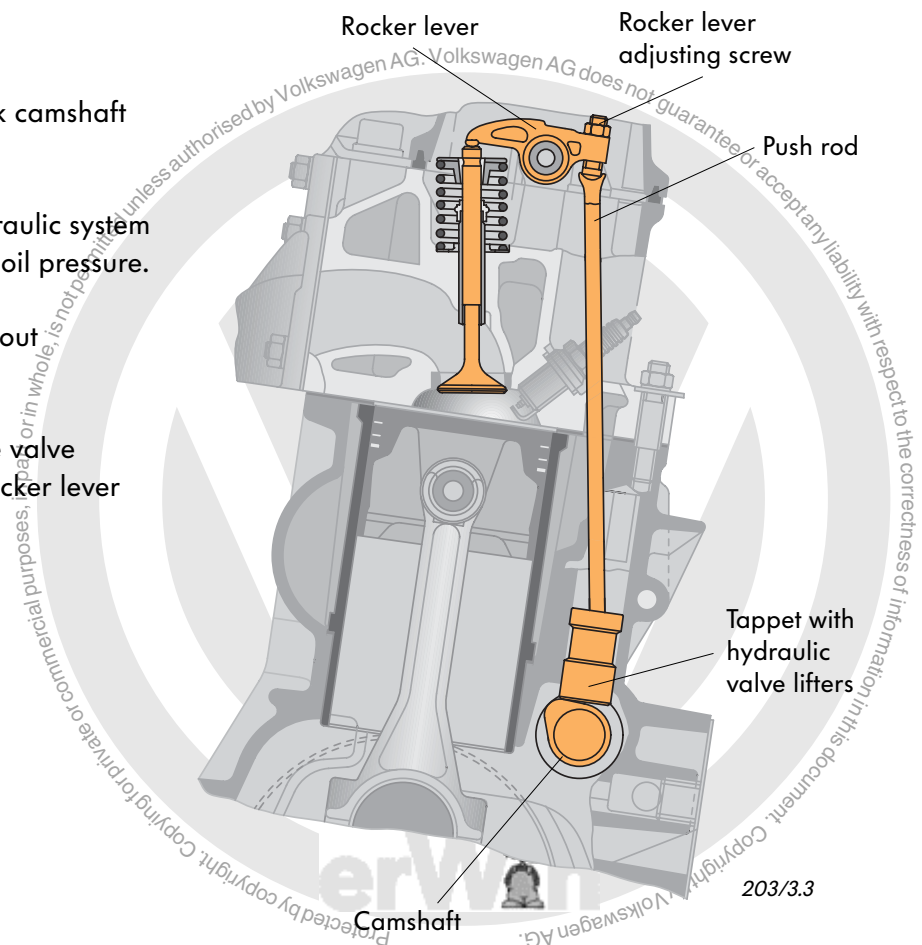

The tappet and the hydraulic valve lifters function in the same way as conventional bucket tappets. (For a description of the bucket tappet, please refer to SSP 105).

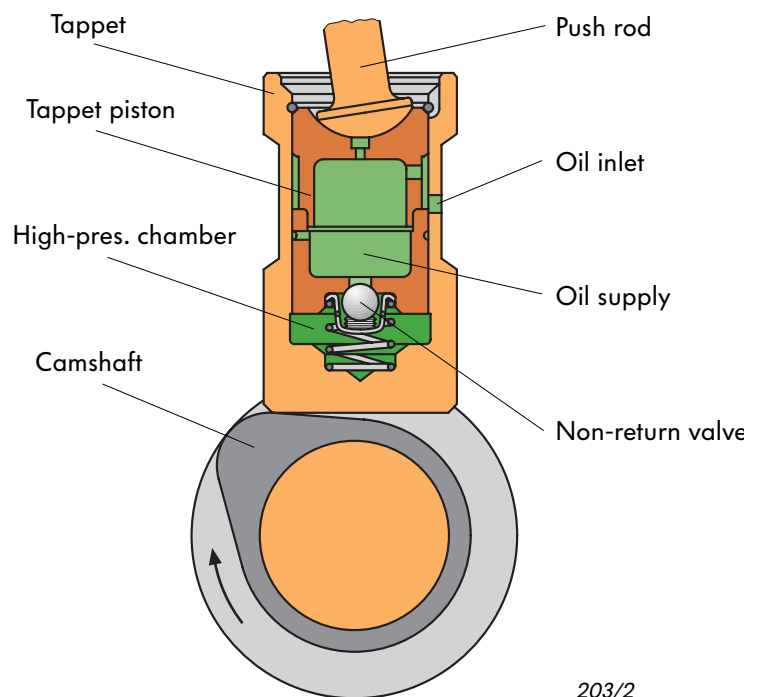

When performing repair work, set down the tappets in their installed position to keep them filled with oil. Absolute cleanliness is essential when carrying out all repairs.

## Drives for auxiliary units

All auxiliary components are driven by the crankshaft via a ribbed V-belt .

In the basic version, these are:

- the coolant pump
- the alternator

The tension of the ribbed V-belt is adjusted via the swivelable alternator.

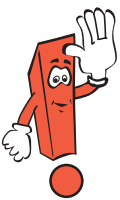

If the engine has a servo pump or an air conditioner compressor, the ribbed V-belt is tensioned by an additional tension pulley.

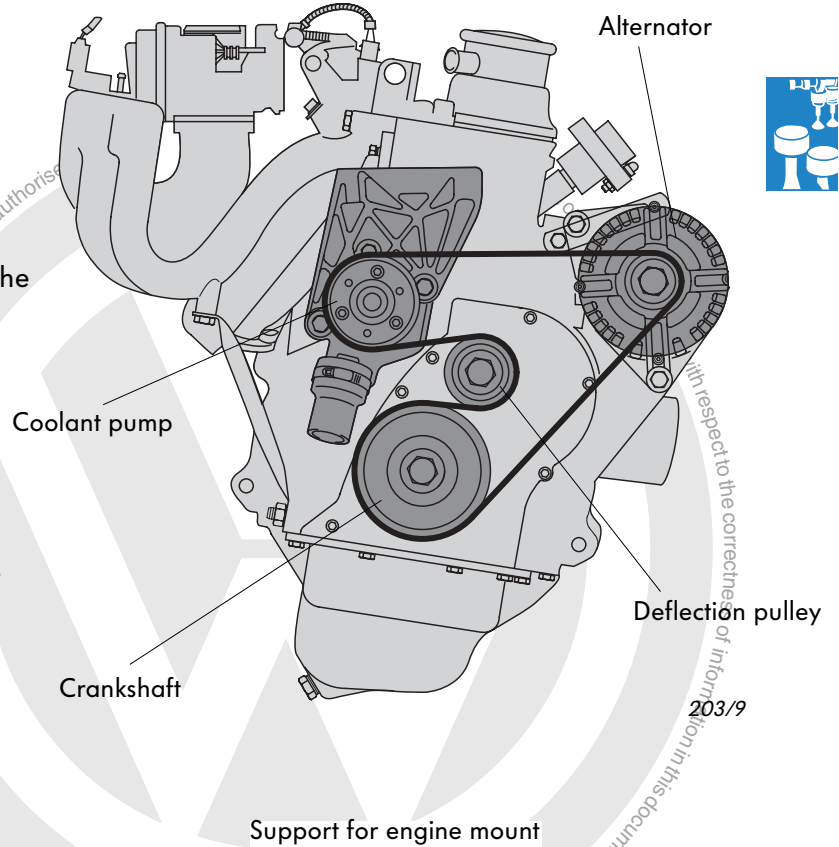

## Coolant pump

The coolant pump is located at the end face of the cylinder block .

The coolant pump bearing housing also serves as a support for the engine mount.

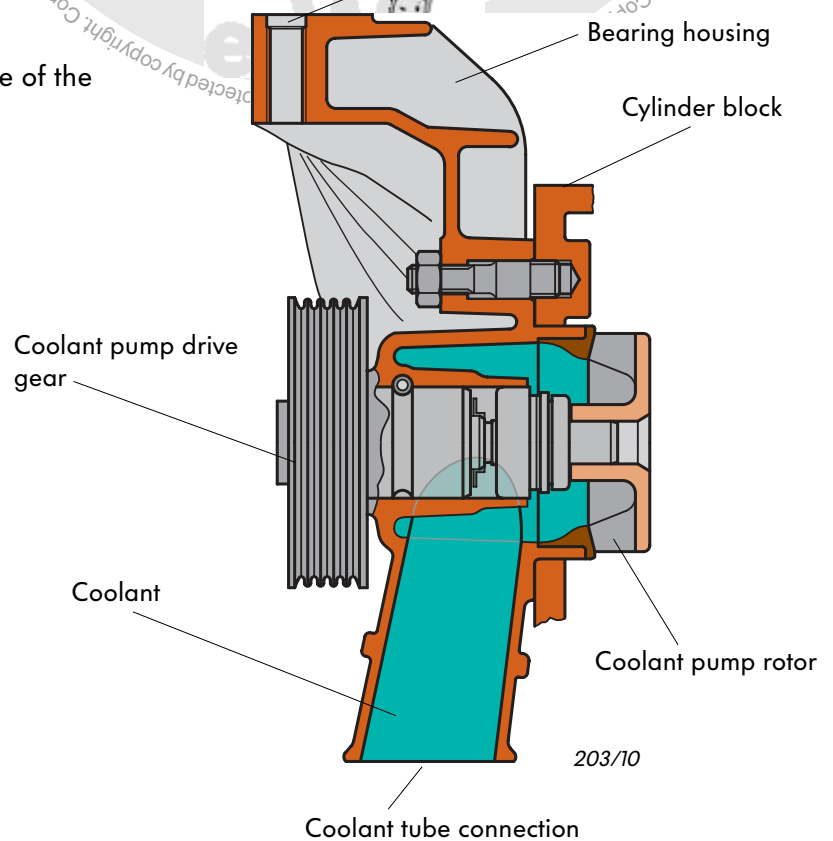

# System overview

## Simos 2P engine management system

The Simos engine management regulates fuel injection and ignition depending on the current engine load.

The engine load is determined by the engine speed sender and the intake manifold pressure sender.

From this, the control unit calculates the ignition point and injection period making allowance for any correction factors.

Correction factors are:

- Cylinder-selective knock control
- Lambda control
- Idling control
- Activated charcoal filter control

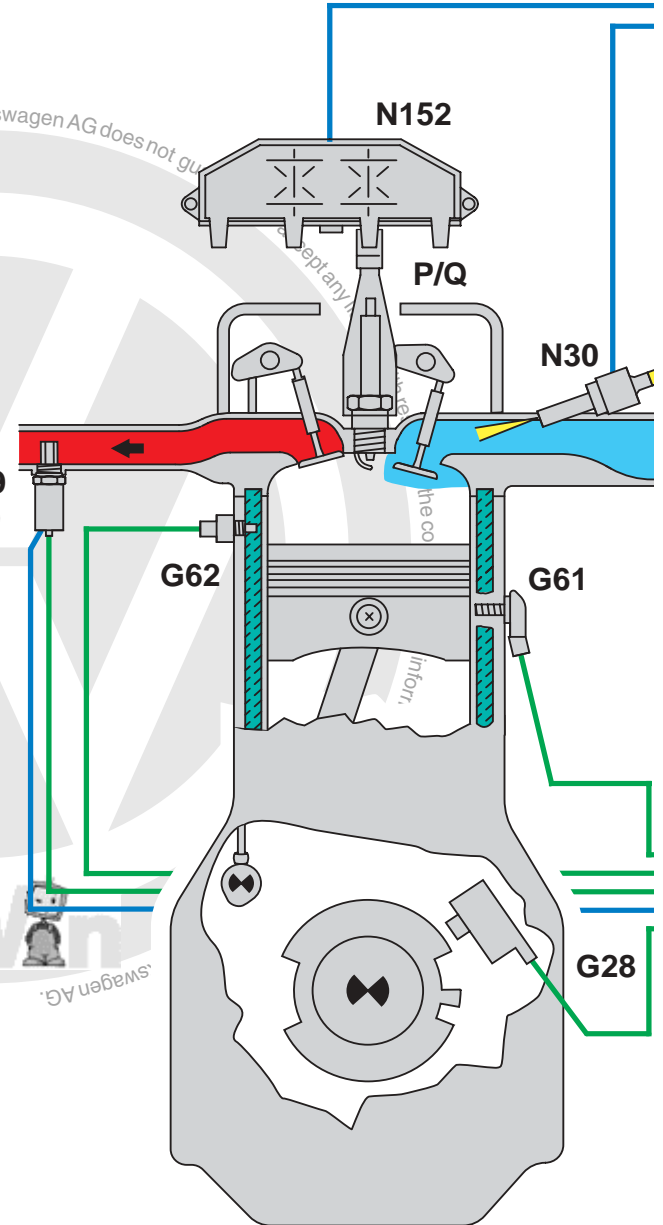

### Legend



G6	Fuel pump
G39	Lambda probe
G28	Engine speed sender
G42	Intake air temperature sender
G61	Knock sensor
G62	Coolant temperature sender
G71	Intake manifold pressure sender
J 17	Fuel pump relay
J361	Simos 2P control unit
J338	Throttle valve control unit
N30	Injector
N80	Solenoid valve for act. charcoal filter
N152	Ignition transformer
P	Spark plug socket
Q	Spark plugs
Z19	Lambda probe heater



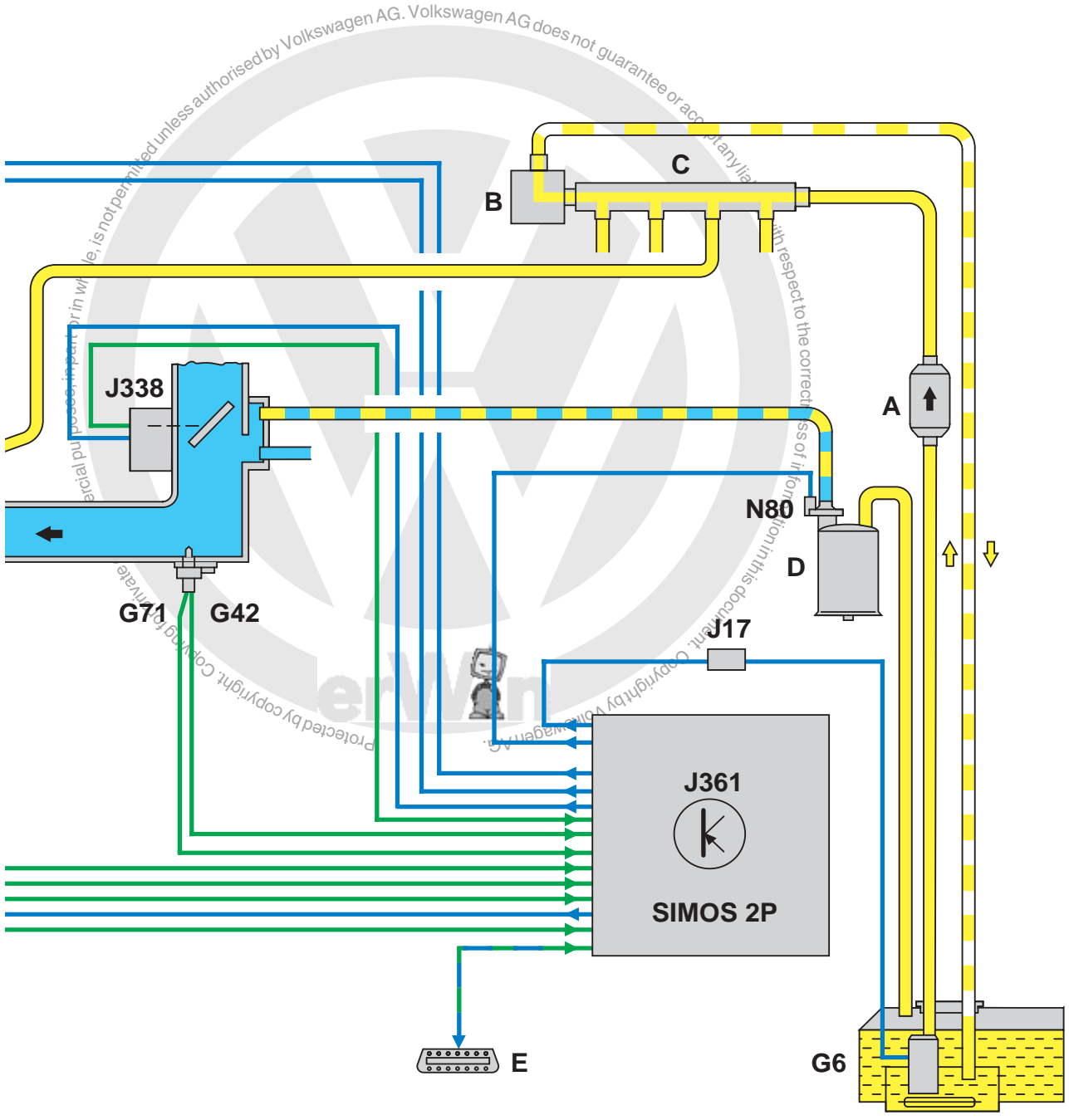
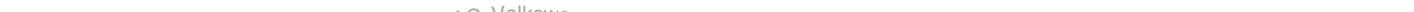



For a description of the throttle valve control unit, please refer to SSP 173.



203/6

 = Output signal  
 = Input signal

A = Fuel filter  
 B = Fuel pressure regulator  
 C = Distributor  
 D = Act. charcoal filter  
 E = Diagnosis plug

 = Fuel supply line  
 = Fuel return line  
 = Intake air  
 = Exhaust gas

# System overview

## Sensors

Engine speed sender  
G28

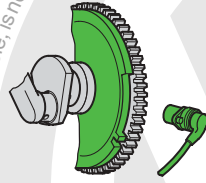

Intake manifold pressure sender G71  
and  
intake air temperature sender G42

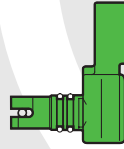

Idling speed switch F60  
Throttle valve positioner  
potentiometer G88  
Throttle valve potentiometer  
G69

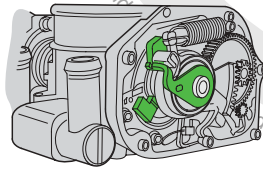

Coolant temperature sender  
G62

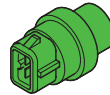

Lambda probe  
G39

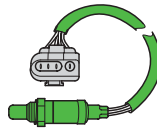

Knock sensor G61



Pressure switch for power steering  
F88



Air conditioner compressor (air conditioner  
switch activation)  
Air conditioner compressor (in)  
Air conditioning system (pressure sensor)  
Road speed signal  
Terminal 50 (starter, ignition switch)

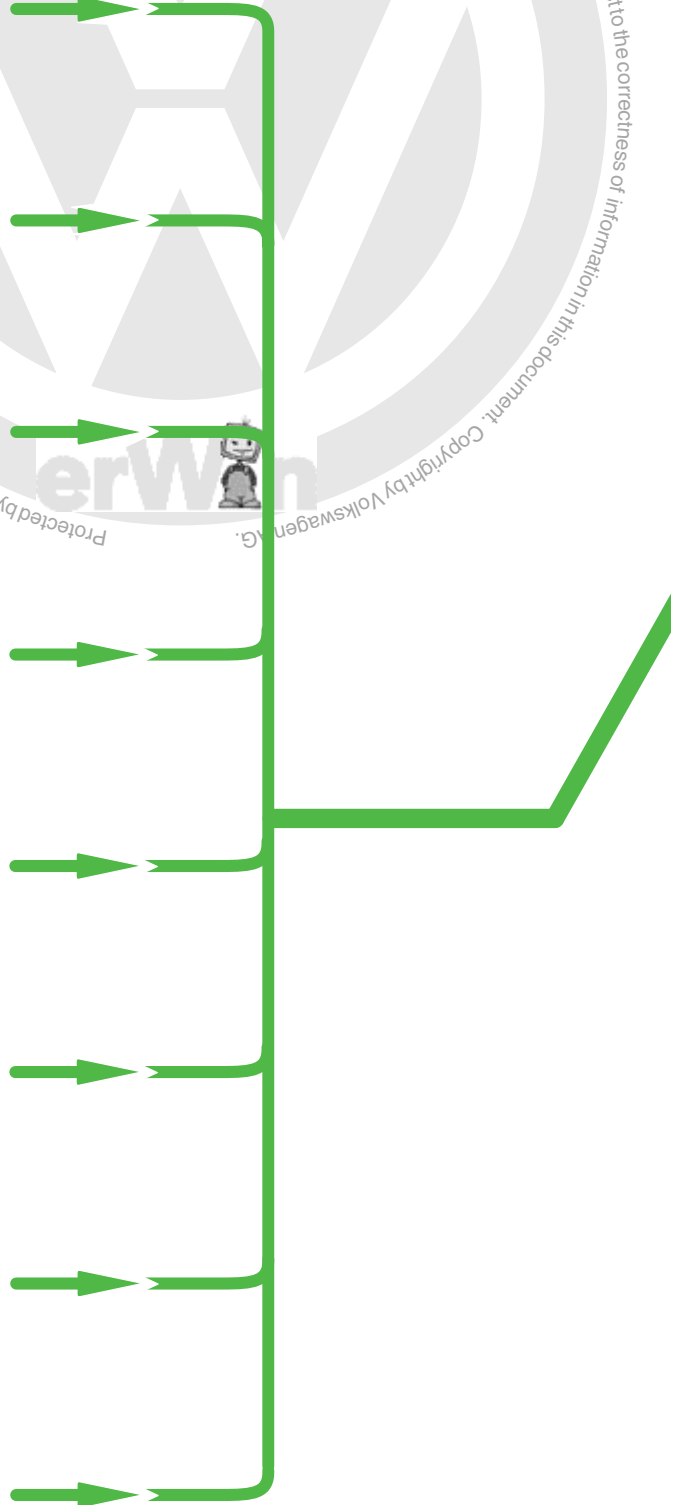

## Actuators

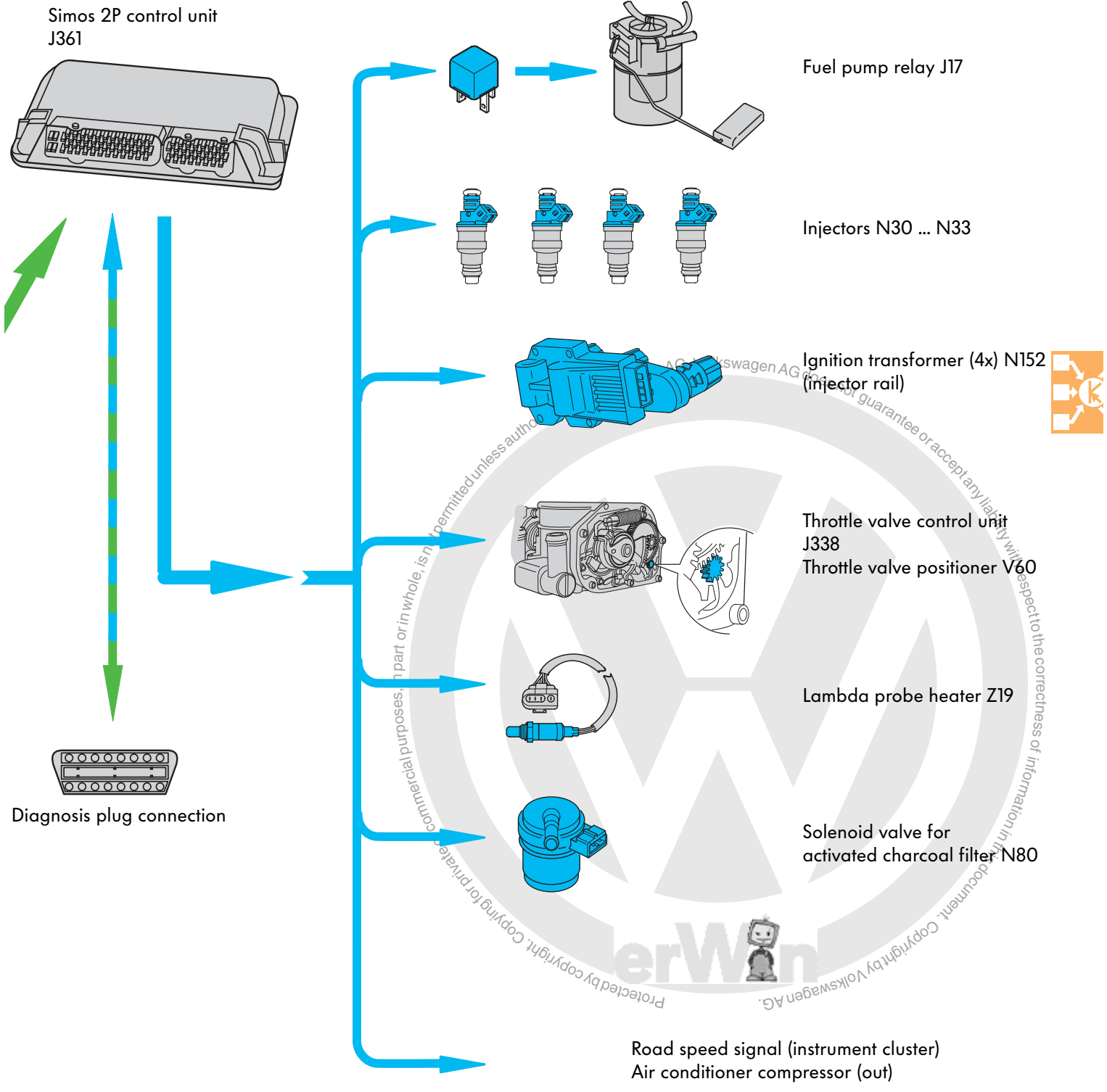

# Sensors

## Engine speed sender G28 and TDC recognition sender

The sender is a sensor which operates in accordance with the Hall principle.

The Hall sender is activated via the segment gaps on the flywheel.

A segment gap is continuous and a segment gap has an additional tooth.

The edges of the segment gaps generate two pulses at an interval of  $48^\circ$  crank angle for every cylinder to be fired.

The control unit recognises these differences from the signal characteristic and assigns the appropriate cylinders.

The engine load control unit utilises the signals to calculate the ignition advance angle and injection point.

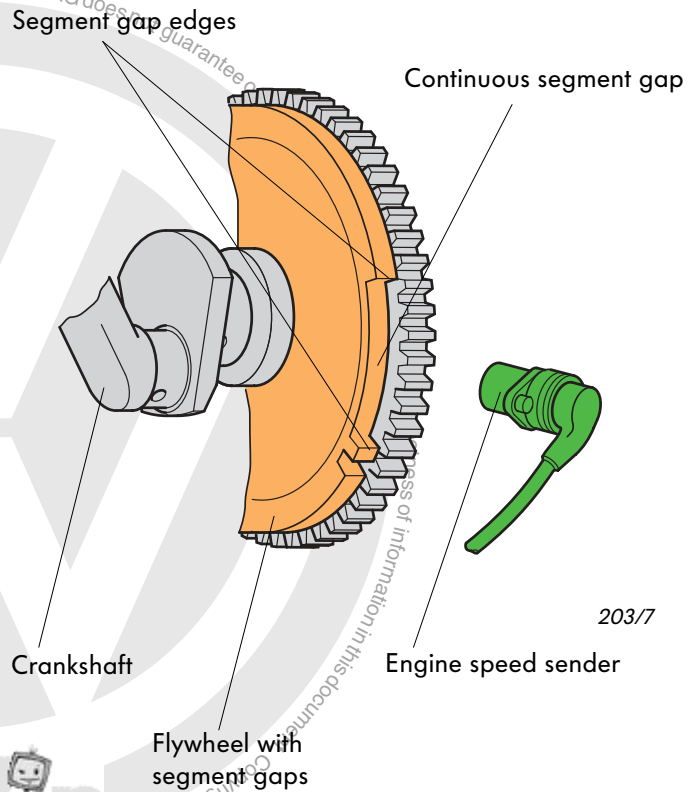

203/7

This difference is important when mounting the flywheel on the crankshaft. The segment gap with tooth must be facing the oil sump at TDC cylinder 1.

The TDC mark on the crankcase is then  $24.5^\circ$  after the edge of the continuous segment gap.

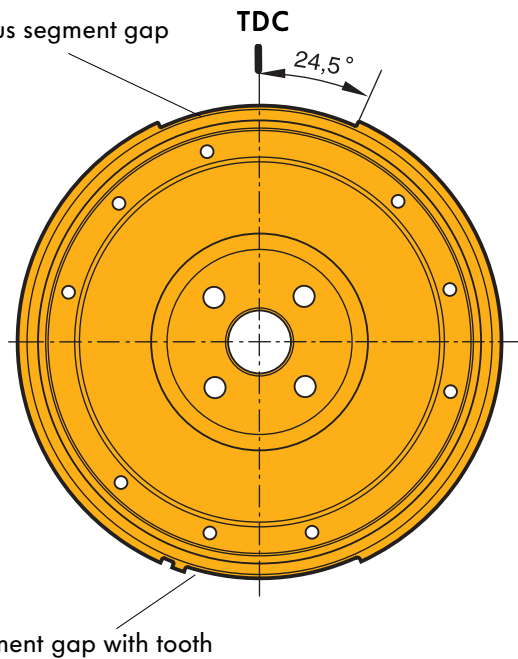

203/8

continuous = cylinders 1 and 4  
with tooth = cylinders 2 and 3

## Intake manifold pressure sender G71 and intake air temperature sender G42

The sender is directly mounted on the intake manifold.

The pressure sensor and air temperature sensor are in direct contact with the intake air in the intake manifold.

### Signal utilisation

Intake manifold pressure and intake air temperature are transferred to the engine control unit.

They are required for calculating the engine intake air quantity.

The necessary injection time as well as the ignition point are calculated using this data.

### Substitute function

If signals are missing, the engine control unit utilises the signal supplied by the throttle valve potentiometer and engine speed to calculate the injection time and ignition point.

An emergency running map is taken as the basis.

If the signal of the intake air temperature sensor is missing, a substitute value of 45°C is utilised.

### Self-diagnosis

The self-diagnosis monitors the two input signals. The following faults can be detected:

- Short circuit to ground
- Short-circuit to positive voltage and reference voltage
- Open circuit

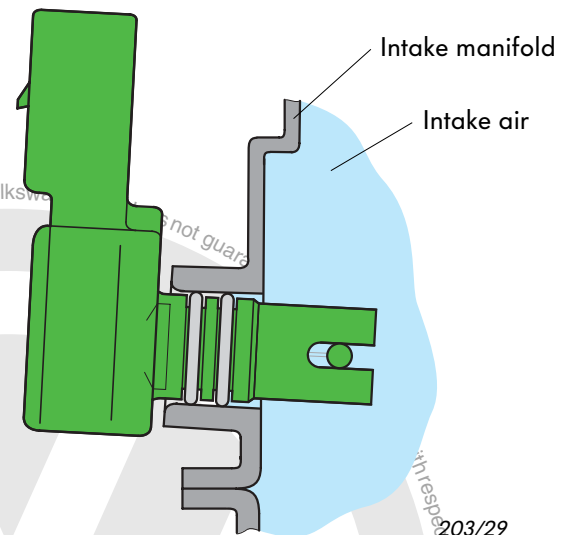

Intake manifold pressure sender and intake air temperature sender

Electrical circuit

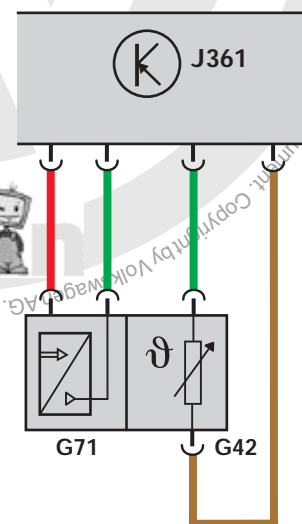

- G42 Intake air temperature sender
- G71 Intake manifold pressure sender
- J361 Control unit for Simos



# Sensors

## Knock sensor G61

The knock sensor is attached to the rear wall of the crankcase between cylinders 2 and 3.

### Signal output

The engine control unit recognises knocking combustion from voltage signals sent by the knock sensor.

This is recorded separately for each cylinder = cylinder-selective knock control

### Signal utilisation

The ignition advance angle of the cylinder in question is shifted towards "retard" in steps of 0.5 to 2° until the tendency to knock diminishes.

The maximum possible ignition angle adjustment is 15°.

The ignition point can thus be adjusted individually to the knock limit for every cylinder. If no further knocking occurs, the ignition advance angle returns to the mapped value in steps of 0.5° crank angle.

### Substitute function

If a signal is missing, the ignition advance angle of all 4 cylinders is reduced by 15°.

This leads to a reduction in engine performance.

### Self-diagnosis

The self-diagnosis is activated at a coolant temperature of 20°C, an engine speed of over 3350 rpm and an engine load of over 60 %.

The fault "Sensor signal too weak" is detected.

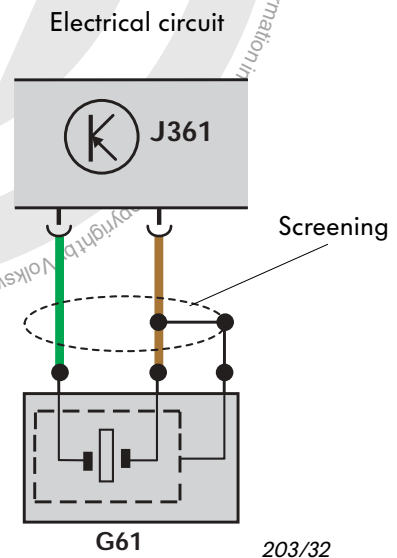
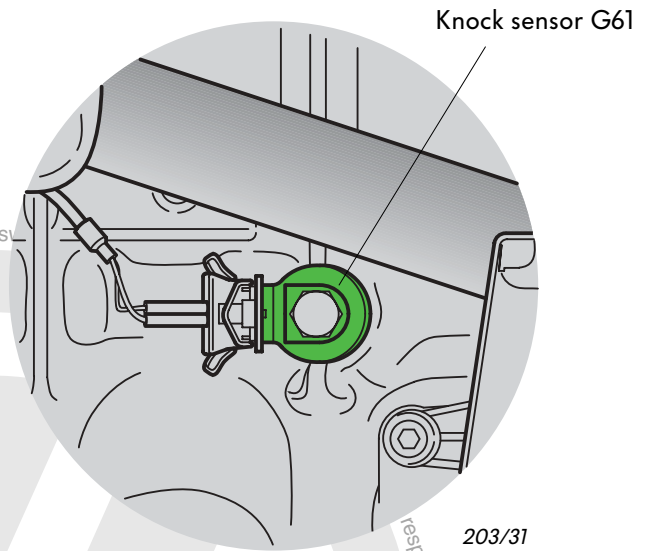

G61 Knock sensor  
J361 Control unit for Simos

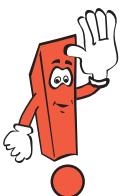

The tightening torque of the fastening bolt has a bearing on the function of the knock sensor. It is essential to adhere to the prescribed tightening torque of 20 Nm.

# Injection system

## Intake module

The intake module carries the fuel rail together with the injectors, the pressure regulator, the intake air sender and intake manifold pressure sender

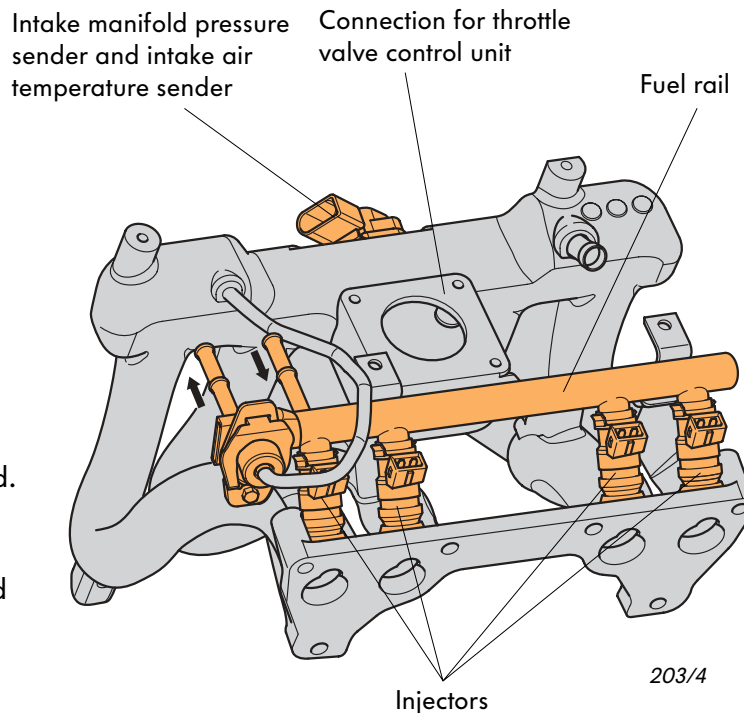

## Injection

Each cylinder has an injector which is located upstream of the intake valve in the intake manifold.

The injected fuel is collected in the intake port and drawn into the combustion chamber with the air when the intake valve opens.

## Activation

The injectors are supplied with power via the fuel pump relay and activated by the control unit via GND.

The injectors are activated in pairs (semi-sequential injection) (cylinders 1 and 4 as well as cylinders 2 and 3).

The control unit makes allowance for the following correction factors when determining the opening time of the injectors:

- Cylinder-selective knock control
- Lambda control
- Idling control
- Activated charcoal filter control.

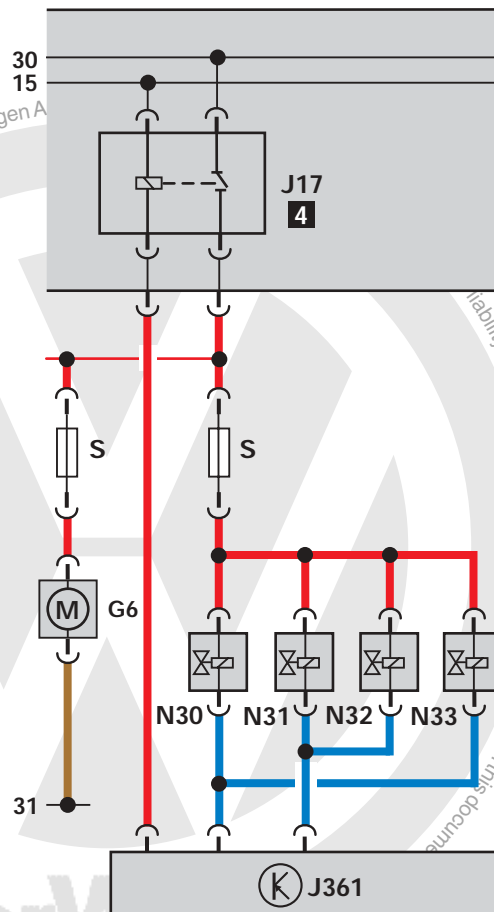

203/16



# Functional diagram

## Functional diagram of Simos 2P

### Components

A	Battery
F60	Idling speed switch
F88	Power steering pressure switch
G6	Fuel pump
G28	Engine speed sender
G39	Lambda probe
G42	Intake air temperature sender
G61	Knock sensor
G62	Coolant temperature sender
G69	Throttle valve potentiometer
G71	Intake manifold pressure sender
G88	Throttle valve positioner pot.
J17	Fuel pump relay
J361	Control unit for Simos
J338	Throttle valve control unit
N152	Ignition transformer (4x)
N30...33	Injectors
N80	Solenoid valve for activated charcoal filter
P	Spark plug socket
Q	Spark plugs
S	Fuse
V60	Throttle valve positioner
Z19	Lambda probe heater

### Auxiliary signals

A	Engine speed
B	Air conditioner compressor (in - out)
C	A/C ready (in)
D	Air conditioner switch activation
D	Air conditioner PWM (in)
E	Check signal, e.g. for "Air conditioner load"
F	K-wire (for diagnosis)
F	Road speed signal
G	Terminal 50

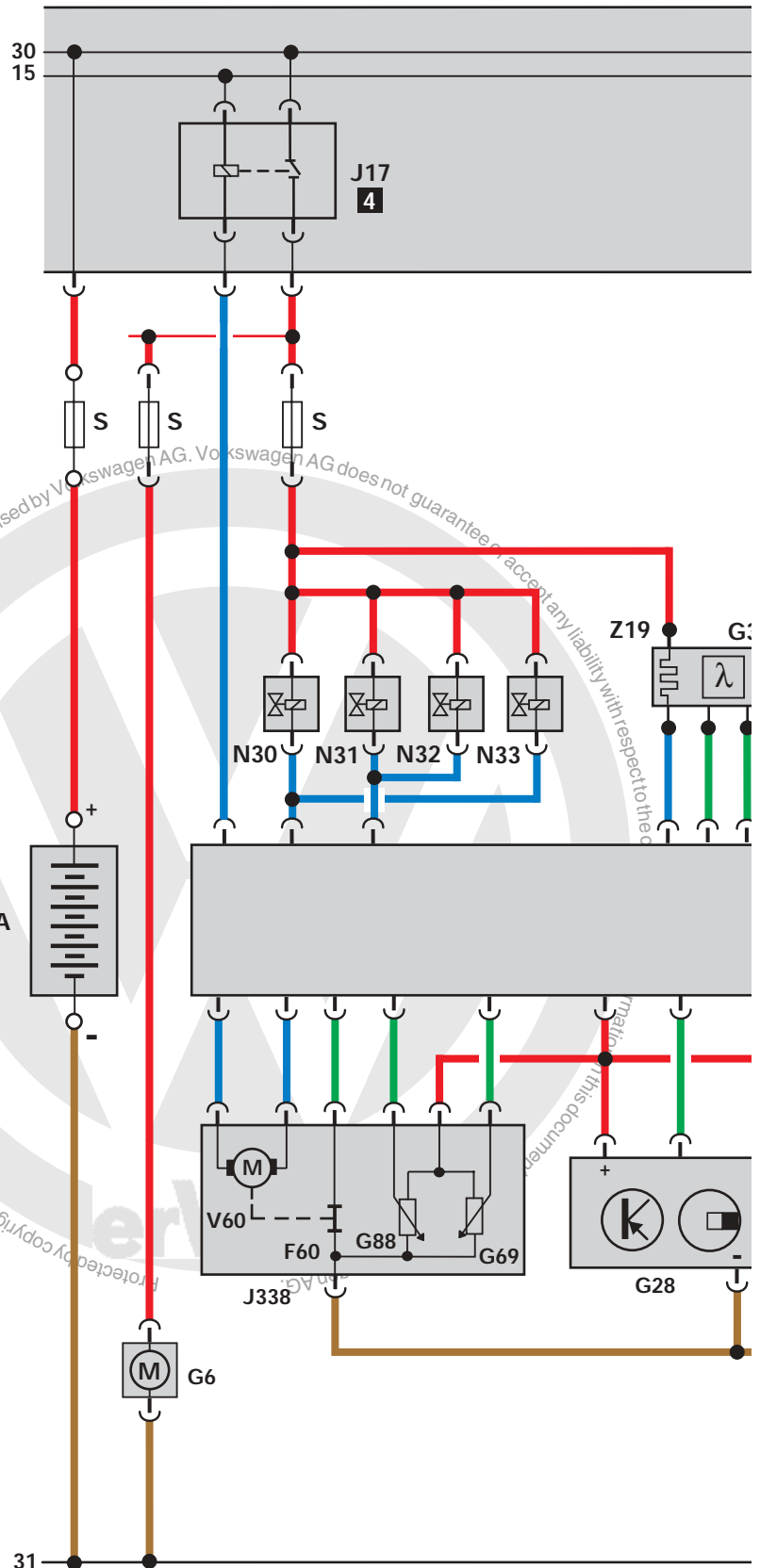

### Code codes/Legend

- = Input signal
- = Output signal

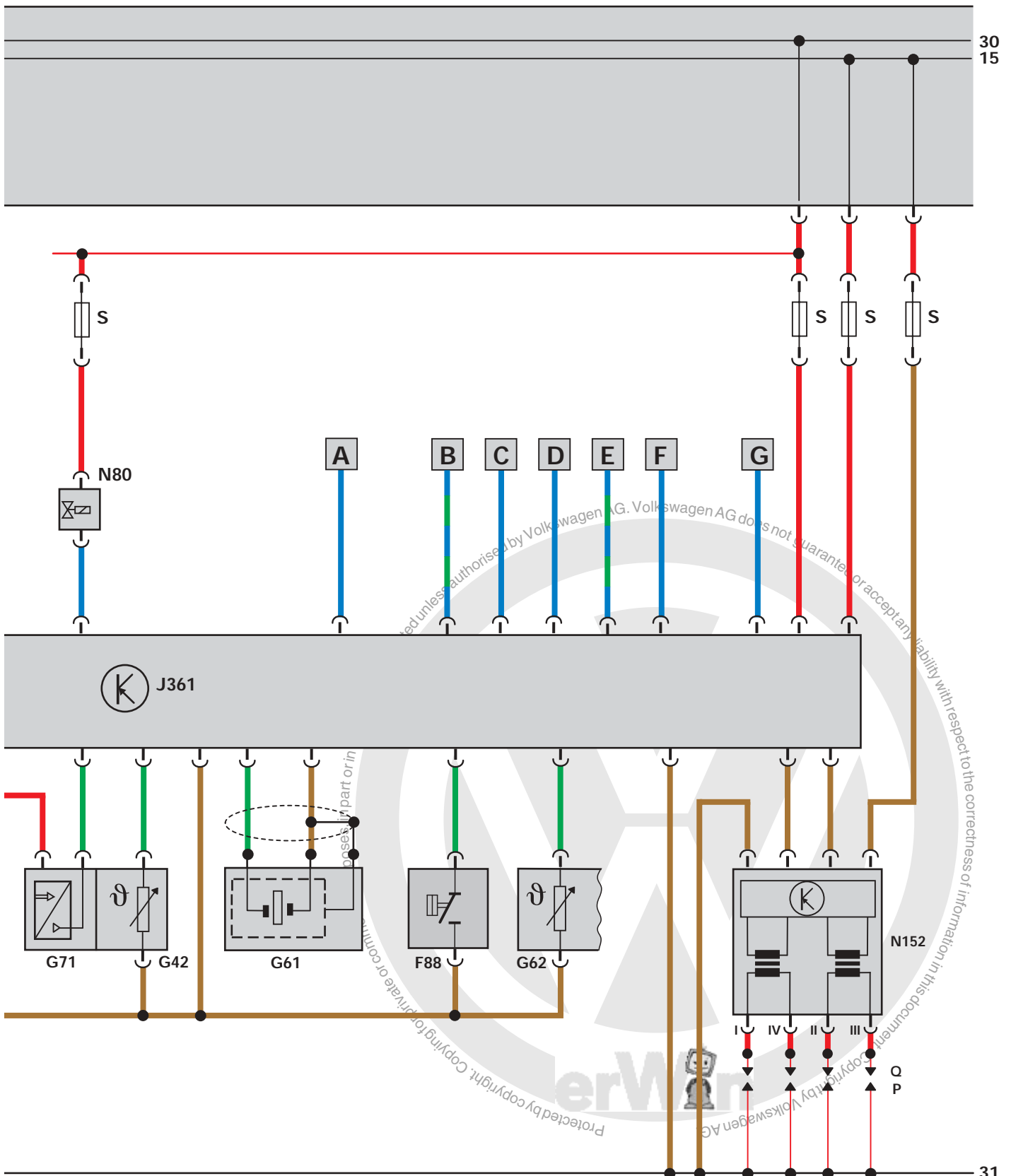

Protected by copyright. Copying for private or commercial use without the express or implied consent of Volkswagen AG. Volkswagen AG does not guarantee or accept any liability with respect to the correctness of information in this document.



# Self-diagnosis

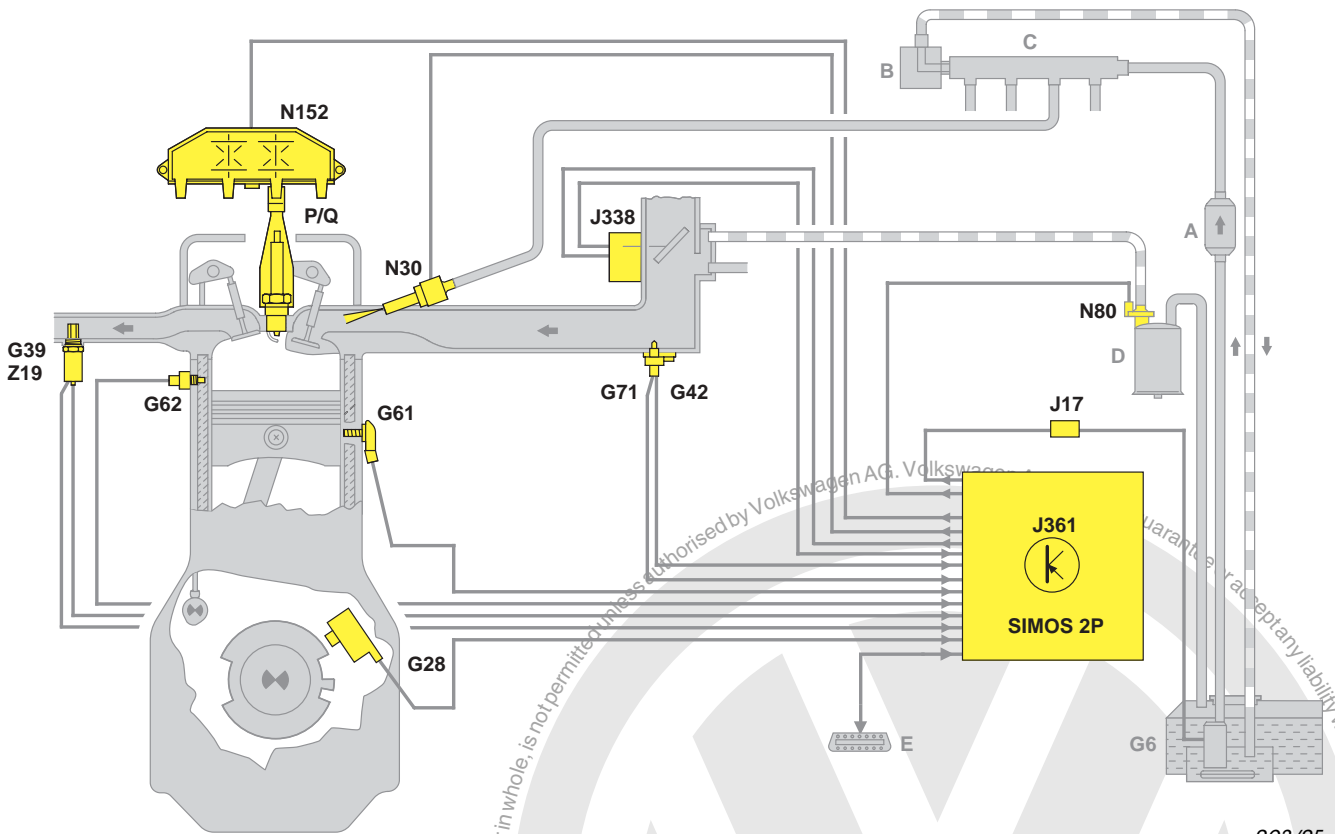

203/25

The self-diagnosis monitors the sensors, the actuators and the control unit. If the control unit identifies a fault, it calculates substitute values from the other input signals and provides emergency running functions. The fault is saved to the fault memory. In addition, measured values are displayed in the read measured value block function for troubleshooting purposes.

All colour-coded system components are contained in the self-diagnosis. Self-diagnosis can be performed with fault readers V.A.G 1551, V.A.G 1552 and VAS 5051.

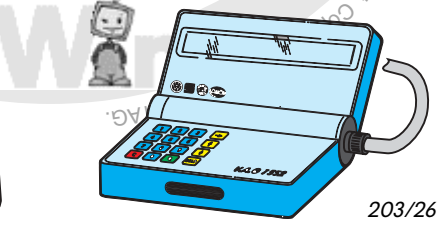

203/26

The following functions are possible:

- 01 Interrogate control unit version
- 02 Interrogate fault memory
- 03 Actuator diagnosis
- 04 Interrogate basic adjustment
- 05 Erase fault memory
- 06 End of output
- 08 Read measured value block

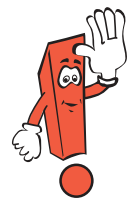

For detailed information on the self-diagnosis procedure, please refer to the Workshop Manual 1.0-ltr./37 kW Engine Simos Injection and Ignition System.



# Test your knowledge

1. C; 2. B; 3. a chain, count the chain pins;  
4. flywheel, engine speed sender, an additional tooth, 1 and 4, 2 ad 3;  
5. A, C; 6. C; 7. A, B, C; 8. B; 9. A, C



Copying for private or commercial purposes, in part or in whole, is not permitted unless authorised by Volkswagen AG. Volkswagen AG does not guarantee or accept any liability with respect to the correctness of information in this document. Copyright © 2022 Volkswagen Group of Companies

**KNOW-HOW**  
  
**SSP 203**  
203/22  
**Solutions**



# Test your knowledge

What answers are correct?

Sometimes only 1 answer is correct.

However, more than one answer may be correct – or maybe all the answers are correct!

Please fill in the spaces .....

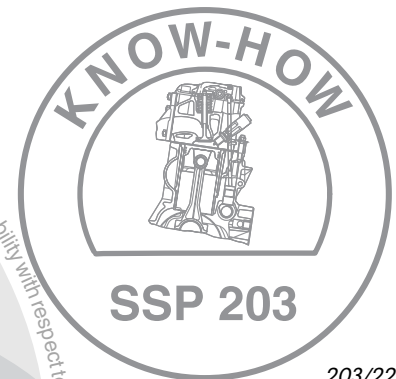

203/22

1. Valves are controlled

- A. directly by the horizontal camshaft,
- B. via rocker lever,
- C. via push rods and rocker lever.

2. Basic adjustment of valve clearance is performed during assembly.

- A. The valve clearance must be adjusted every 15,000 km or during the annual inspection.
- B. As hydraulic valve tappets are used, there is no need for mechanical adjustment during inspections.
- C. The basic adjustment must be repeated after a mileage of 1,000 km.

3. The camshaft is driven by .....

Valve timing is adjusted by means of ..... from mark to mark.

4. Segments for recognition of ..... are attached to the .....

A segment carries .....

This makes it possible for the control unit to distinguish whether the signal belongs to cylinders ..... and ..... or ..... and .....



5. The intake module carries the fuel rail together with the injectors.
- A. Each cylinder has an injector.
  - B. Fuel is injected directly into the combustion chamber.
  - C. Fuel is injected into the intake manifold upstream of the intake valve.

6. The injection system operates semi-sequentially.

Semi-sequentially means:

- A. Fuel is injected in two steps.
- B. Fuel is injected sequentially, not simultaneously.
- C. Two injectors inject fuel simultaneously (groups 1 and 4 as well as 2 and 3).

7. The engine has wet type cylinder liners.

This means that

- A. The coolant sweeps the cylinder liners directly,
- B. The cylinder liners are not an integral part of the cylinder block,
- C. Cylinder liners can be replaced when repair work is necessary.

8. The oil pump is driven

- A. by the crankshaft by means of a chain,
- B. by the camshaft by means of a shaft,
- C. by the camshaft by means of a chain.

9. The coolant pump is located on the face end of the engine.

- A. It is driven by means of the common ribbed V-belt for driving all the auxiliary components.
- B. It is driven by means of a separate V-belt.
- C. Its bearing housing also serves as the support for the engine mount.



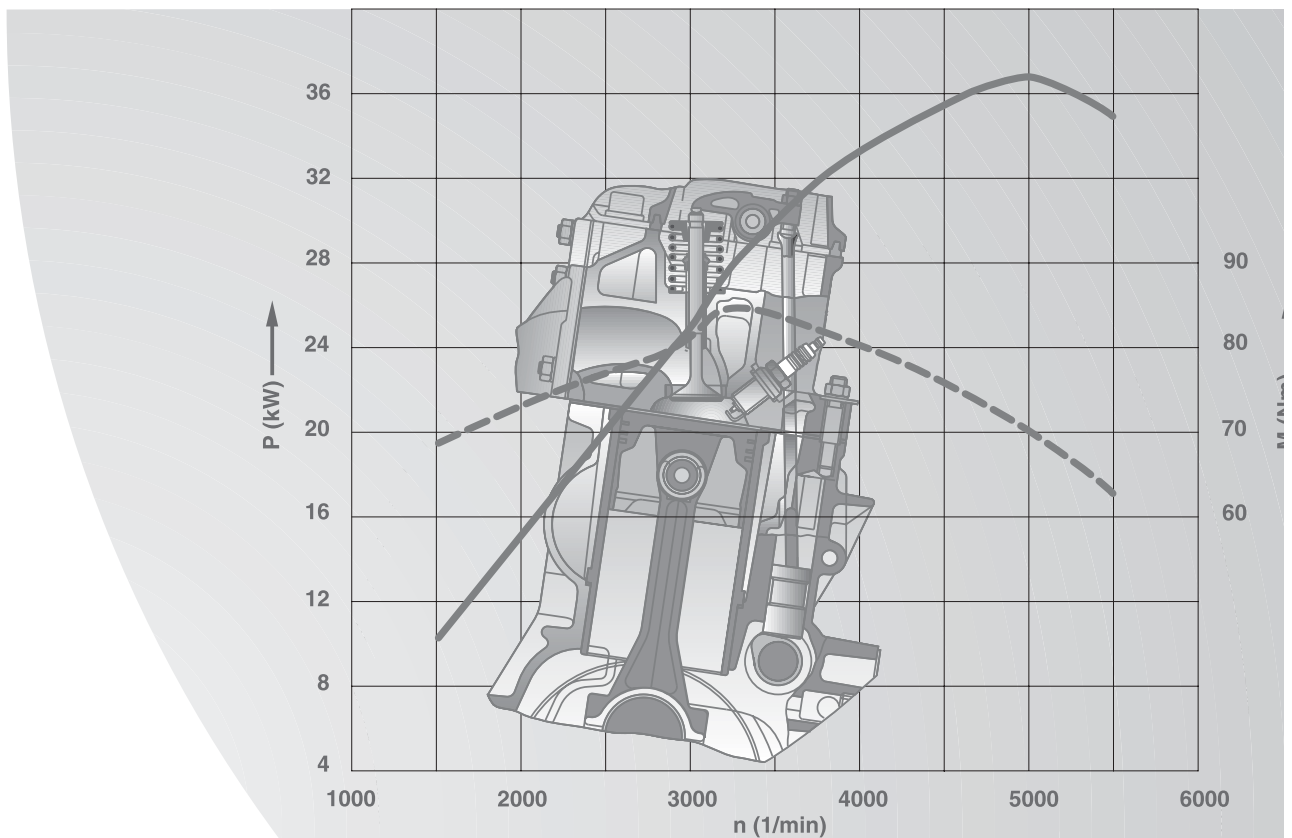

For internal use only. © VOLKSWAGEN AG, Wolfsburg

All rights reserved. Technical specifications subject to change without notice.

840.2810.22.20 Technical status: 05/98

This paper is produced from  
non-chlorine-bleached pulp.

